



EUREKA

ANNUAL
PROGRESS
REPORT

4412.35 E



1993

INTRODUCTION

EUREKA: An innovative tool

Launched in 1985, EUREKA has proven an innovative tool helping Europe, through intensified research and development cooperation, to master and exploit the technologies which will be decisive in the worldwide race for competitiveness and in the search for better quality of life.

EUREKA interacts with companies and research institutes in EUREKA member countries and helps them pool their resources in the development of leading edge technology.

The Annual Progress Report 1993 provides a general picture of EUREKA's project portfolio as of 15th October, 1993. The more than 650 actively running projects covered in this report have a total estimated cost of around 13 billion ECU and involve some 3,500 participants, over 1,500 of which are larger companies, some 750 small and medium sized companies, more than 1,000 research institutes including universities and about 200 other organisations. More than 30 participants come from non-member countries, most of these are from Europe.

This report also gives an overview of the more than 100 EUREKA projects which have already finished. These had a total volume of about 1.6 billion ECU thus bringing the total cost of ongoing and finished EUREKA projects to close to 15 billion ECU.

EUREKA's Members are:

Austria
Belgium
Denmark
European Union
Finland
France
Germany
Greece
Hungary
Iceland
Ireland
Italy
Luxembourg
the Netherlands
Norway
Portugal
Russian Federation
(since 29 November 1993)
Spain
Sweden
Switzerland
Turkey
United Kingdom.

EUREKA: An open initiative

"Bottom up" is EUREKA's ground rule. Participants have full responsibility for defining and implementing their scientific and technological cooperation projects. They are their own judges of the best course towards new markets for Europe.

EUREKA's structure is built to mobilise the dynamism and innovative strength in Europe's industry and research. The ground rule prevents unnecessary bureaucracy and provides a simple set of criteria for establishing EUREKA projects. The most important of these criteria require the project to

- involve at least two partners from different EUREKA members,
- aim at securing a significant technological advance in the product, process or service concerned,
- be oriented towards applications in the civilian sector.

Any company or research institute in a EUREKA member country, which has a proposal meeting the EUREKA project criteria is invited to contact the relevant National Project Coordinator (NPC) listed on pages 50-51.



The NPC will advise and assist the applicant and handle further contacts within the EUREKA structure, thus allowing industry and research institutes to concentrate on the content and business aspects of the proposed projects. The application procedure to establish or join a EUREKA project is very simple and so constructed that a well founded project can be up and running relatively quickly.

In the Central and Eastern European countries a network of EUREKA National Information Points has been set up to provide the industries and researchers in these countries with an easy interface to EUREKA and distribute EUREKA information in their countries.

EUREKA: Added value

EUREKA projects and participants are eligible to carry the EUREKA Seal - an internationally recognised hallmark of excellence. The participants will also be included in EUREKA's open database which lists by name and technological skills some 4000 of Europe's foremost companies and research institutes. As such, a EUREKA participant is marketed all over Europe and is likely to attract attention and contacts from partners searching for specific technological skills to develop new products, processes or services.

EUREKA also offers itself as a forum for direct dialogue between governments and standardisation bodies on the one hand and EUREKA participants who are in need of joint industrial standards or who are hampered either by technical obstacles to trade or by barriers to public procurement on the other.

EUREKA projects have in many cases access to public financial backing for their research and development activities. The participants themselves are, however, responsible for securing adequate funding.

EUREKA also acts as a contact point and support for participants seeking access to private funding sources, such as venture capital.

EUREKA possesses considerable experience in crossborder cooperation and will assist participants who request help in drafting project contracts.

EUREKA:

A flexible decentralised structure

National Project Coordinators

The NPCs are, together with the EUREKA Secretariat, the operational core of the EUREKA network.

They run the national EUREKA offices and are the interface between participants and the EUREKA network. They also form a link with the relevant national authorities and are in close contact with their counterparts in the other EUREKA Members.

Through the NPC network, the national EUREKA offices will usually be able to find suitable partners for their industry or research institutes and help them create sound projects.

EUREKA Secretariat

The Secretariat is EUREKA's central support unit located in Brussels. It gathers and distributes information on projects and EUREKA as such, runs the project database, assists the various bodies of the initiative, facilitates contacts between partners and promotes the EUREKA concept in conjunction with national authorities.

High Level Group

This Group is made up of High Level Representatives appointed by the EUREKA governments and the Commission of the European Communities. It formulates general EUREKA policy for approval by the Ministerial Conference. It also monitors the implementation of ministerial decisions.

Ministerial Conference

The Ministerial Conference is the political body of EUREKA and is responsible for furthering the Initiative and its aims.

It is composed of ministers from the now twenty-one EUREKA member countries and a Commissioner from the European Commission.

It meets, as a rule, once a year to lay down the political guidelines for EUREKA's work and officially announces the new EUREKA projects launched since its previous meeting.

STATISTICAL TABLES

Total cost of ongoing projects by area (MECU)



Number of ongoing projects by area



Participation in ongoing projects by member



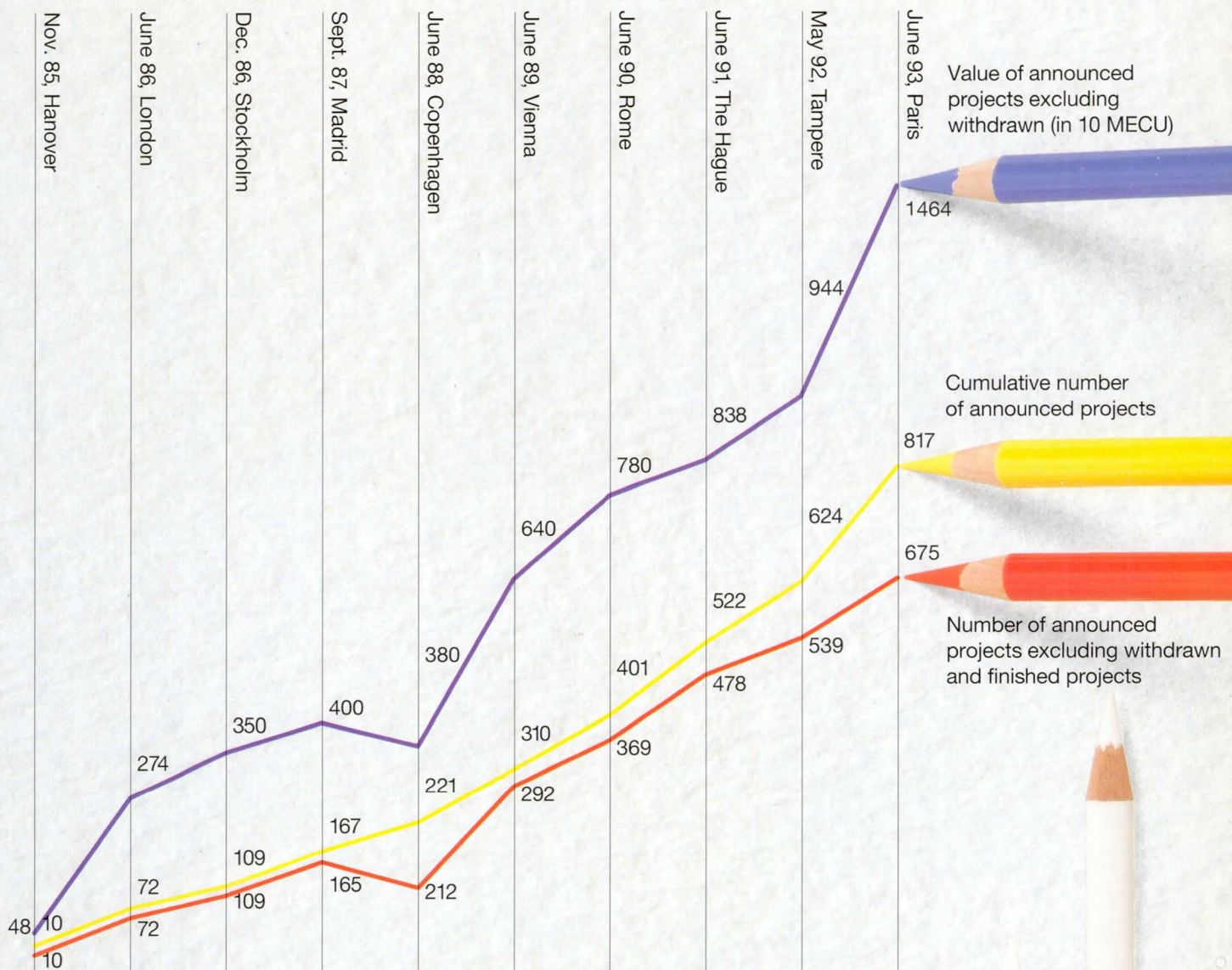

Abbreviations used in this report:

- BIO Medical and Biotechnology
- COM Communication Technology
- ENE Energy Technology
- ENV Environment Technology
- INF Information Technology
- LAS Laser Technology
- MAT Material Technology
- ROB Robotics and Production Automation
- TRA Transport Technology

Source of data in this report:
EUREKA database as at 15 October 1993

Number of projects announced by Ministerial Conference



INTRODUCTION BY FRANÇOIS FILLON, FRENCH MINISTER OF HIGHER EDUCATION



Mr. François Fillon

Eight years after its 1985 launch, the EUREKA Initiative is expanding rapidly and is now an internationally recognised hallmark of quality.

The XIth Ministerial Conference held in Paris on 24th June, 1993 provided an opportunity to evaluate our progress. The result is positive because the number of announced projects was an all time record and a high percentage of them reached their industrial and commercial stage with a significant impact on European Industry.

Success is due initially to the researchers and European industrialists who, despite the difficult economic climate, have doggedly maintained their competitiveness on world markets. However, success is also due to EUREKA's flexible, decentralised philosophy, particularly appreciated by companies.

The French Chairmanship was run in the same spirit of continuity and consolidated the initiatives launched by the Finnish Chair. Its tasks fell within the first year framework of EUREKA's Medium Term Plan (1992-1996) and emphasis was placed on 5 main areas:

1. Produce an initial evaluation of the industrial and socio-economic results of the projects,
2. Increase SME participation in EUREKA, particularly as project leaders.
3. Encourage new initiatives in 6 areas of strategic importance for European industry,
4. Strengthen links with the E.U.
5. Develop relationships with Central and Eastern European countries.

The French Chair took the initiative to carry out the first large scale evaluation of EUREKA's economic and industrial impact. This analysis, considering its wide scope, is an unprecedented experiment in the evaluation of European industrial research.

Led by independent experts, under the aegis of Professor Ormala, its results show that EUREKA has achieved its main objectives: support to market-oriented projects, reinforcing participant competitiveness, beneficial industrial and commercial impact.

With 94 finished projects, 48 of which ended during the French Chair, EUREKA has now reached industrialisation.

This number should significantly increase over the next 3 years. Most projects are both innovative and productive. They go far beyond the granting of patents and combine competitiveness with high technological standards in European Industry. Lastly, their impact can already be felt on the daily lives of Europeans, as the exhibition "Innovation on a Daily Basis" (L'Innovation au quotidien), organised at the Cité des Sciences during the XIth Ministerial Conference clearly demonstrated.

The evaluation also showed that EUREKA is a particularly suitable medium for SMEs. Their increased participation was a priority of the Member States and a major aim of the French Chairmanship. The evaluation produced at the Ministerial Conference in Paris shows that this objective has certainly been achieved: of the 193 projects announced, 77 have an SME as project leader.

Nonetheless, the evaluation stressed - as did the Dekker Report - that a difficulty specific to SMEs is their weak self-financing position which makes them very vulnerable to vagaries of financing synchronisation between member states. Several decisions on principle, allied to the openness of information during project evaluation and the guarantee of means to achieve them when EUREKA status is granted, were taken during the French Chairmanship to enable examination and a rapid start to projects initiated by SMEs as well as their unified launch in all the countries involved.

Among the objectives set by the French Chairmanship, was the definition of actions to facilitate the emergence of projects in six strategic areas on economic, technological and industrial lines. Six conventions were organised in 1992 and 1993: agrofood, automotive, biological diagnostic, data processing, factory of the future and treatment of wastes. These drew 1,500 participants representing 18 EUREKA countries and 7 Central and Eastern European countries, with a sizeable SME contingent.

The interest expressed by European industrialists during these conventions has found tangible expression in the high number of new projects in these areas: 125 projects emanate from these strategic initiatives and have a total value of 1,600 MECU.

The French Chairmanship's 4th objective was to reinforce links between EUREKA and the E.U. R & D programmes. Work in this area has resulted in a positive collaborative spirit, and has defined, to the benefit of industrialists and European researchers, some complementary principles.

The documents adopted by the HLG during its Cayenne meeting show a common willingness to work closely together while respecting each other's individual character, a cause which the European Council in Edinburgh defended in December, 1992.

A flexible network grouping together experts from the E.U. and EUREKA representatives was set up, leading to better information exchange with regard to community proposals or EUREKA projects in their initiation stages. Along the same lines, demonstrations in Pont-à-Mousson and Brussels, relating to language engineering and the automotive industry respectively, were organised jointly by the French Chairmanship and the E.U. as well as a joint workshop during the "Computer Integrated Manufacturing" conference last May.

Constant information exchange, targeting R&D projects towards the most appropriate framework are measures which will be actively pursued by the Norwegian Chair.

EUREKA's originality, however, resides in allowing the European technology net to widen. After the admission of Hungary in 1992, Russia achieved membership in Paris. By setting up cooperation projects, EUREKA allows Central and Eastern European countries to form links, as they seek a new democratic identity, with research efforts elsewhere in Europe. Through the promotion of technological innovation allied to economic factors and local conditions, EUREKA has an obvious role to play: a contribution to the construction of a strong and powerful technological and industrial Europe.

Given the difficult economic climate, Technological Europe is seeking its way and our Chairmanship found itself confronted with a very specific responsibility to buoy up EUREKA's success.

If we can be proud today of the work we have done and the results achieved, we would above all like to thank all EUREKA members as well as the EUREKA Secretariat for their support and enthusiasm, with a special mention to our Norwegian friends to whom we wish every success.



MESSAGE FROM JENS STOLTENBERG, NORWEGIAN MINISTER OF INDUSTRY AND ENERGY



Mr. Jens Stoltenberg

Launched only eight years ago, the EUREKA Initiative can today be characterised as a major success. The rapid growth and sound development of EUREKA suggest that the Initiative was conceived and implemented in a fashion that is fundamentally correct with respect to the needs of industry. The paramount aim of the Norwegian Chair is, therefore, to further strengthen the basic concept of EUREKA, and thus to maintain and perhaps even increase the level of success.

My own country is one of the most active users of EUREKA. Norwegian industry is, perhaps to a greater extent than in other European countries, composed mainly of small and medium-sized enterprises (SMEs). Such enterprises usually do not have the resources necessary for engaging in extensive and complicated efforts aimed at the setting up of multilateral international R&D co-operation. The fact that many Norwegian SMEs participate in EUREKA activities, very distinctively highlights EUREKA's uncomplicated and unbureaucratic "easy-to-use" structure. In the view of the Norwegian Chair, this simplicity is essential for keeping EUREKA attractive to industry and especially SMEs. In the efforts to increase its attractiveness even further, the basic prerequisite is to safeguard the user-friendliness of the Initiative. Consequently, the Norwegian Chair will work in a determined manner to retain EUREKA's simplicity.

Multilateral international R&D co-operation offers many advantages to participating companies, e.g. access to new markets and know-how and sharing risks and resources. While appreciating this, it should not be forgotten that such co-operation will yield the desired effects only if the quality of the initiated projects is good.

The EUREKA Projects Evaluation Report, published in 1993, underlines the necessity of further improvement in the quality of EUREKA projects. The Norwegian Chair is very well aware that the EUREKA organisation can only resort to procedural means to achieve this, and that projects can be influenced only indirectly. Bearing this in mind, attempts will nevertheless be made to raise quality through improved discipline at project start-up, improved monitoring and screening, and improved reporting and evaluation of finished projects.

In connection with the implementation of these measures, great care will be taken so as not to infringe upon the simplicity and user-friendliness of EUREKA.

Traditionally, EUREKA has had a very high profile as regards projects in the area of Environment Technology. In fact, among EUREKA's nine different technological areas, Environment Technology is now the area with the largest number of projects. Nevertheless, the Norwegian Chair feels that there is a need for a mechanism which will ensure that environmental aspects are adequately taken care of in all EUREKA projects. Generally speaking, the Norwegian Chair believes that a sharper focus on environmental issues in industrial development definitely entails more opportunities than problems.

The decentralised awarding of public funding to EUREKA projects contributes to a speedier and well-advised assessment of new project proposals. This mechanism allows project proposals to be assessed locally, i.e. by institutions who know the actors behind the proposals, their field of work and their merits in this field, resulting in faster responses to new proposals.

There is, however, a potential for a further streamlining of this mechanism. While one of the partners in a project may receive the public funding he has applied for within a relatively short time, another may have to wait much longer before public funds are made available. Obstacles of this kind may lead to some slowing down of the "take-off" speed and to reducing the enthusiasm in a new project, or, indeed, the project may be abandoned altogether. The Norwegian Chair has put this issue on the agenda, with the hope that a better synchronisation and transparency of the funding schemes in the EUREKA member countries can be achieved.

Organising brokerage or partnering events is certainly of importance in promoting the EUREKA concept. Such events may serve the purpose of disseminating information on EUREKA, spreading and "selling" findings in ongoing projects, or providing fora for interested parties to find partners in order to be able to generate new collaborative projects.

The Norwegian Chair will support such initiatives by various EUREKA offices. Furthermore, Norway herself will be hosting a major event. This event, called "Vision EUREKA Lillehammer '94", will take place in conjunction with the Ministerial Conference in Lillehammer in June 1994. "Vision EUREKA Lillehammer '94" will consist of no less than 18 parallel and independent technology conferences.

This will allow industrialists and researchers to meet colleagues not only from their own branches but also potential partners from other areas. A joint evening for EUREKA officials and conference participants will provide an opportunity for multilateral contacts. Thousands of people are expected to take part in the event.

Besides being perhaps the main instrument for industrial market-oriented R&D in Europe today, and thus playing a very important rôle in increasing the competitiveness of European industry, EUREKA has another significant dimension. This is in creating goodwill and confidence between European nations. EUREKA can be held up as an excellent example for illustrating how successful and beneficial pan-European co-operation can be. We should keep this in mind in our future work with EUREKA, and in this respect we should also remember that goodwill and confidence between nations is closely linked to economic prosperity, and vice versa.

EUREKA is contributing to both!



EUREKA IN 1993

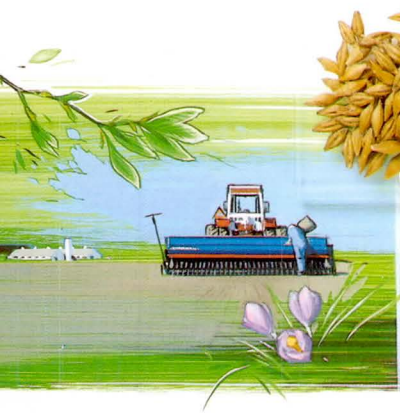

MORE PROJECTS, NEW AND FINISHED

1993 became in many ways EUREKA's most successful year so far.

The EUREKA Ministerial Conference, meeting in Paris on 24 June, announced a total of 193 new projects, more than 50% higher than the previous record established in 1991.

They involve 1010 organisations, of which 73% are industrial companies, and have an estimated cost of around 1,800 MECU, a significant surge in R&D investment despite the economic turbulences of the 1992-1993 period. 35% of the participating SMEs are project leaders, compared to an overall average of 30%. Two thirds of the announced projects concern areas in which promotional activities were carried out.

The Conference also noted that the 1992-93 year had seen 48 projects finish, with a volume of around 1,000 MECU. So in one year more projects were finished than in the previous 7 years combined, both in terms of numbers and of cost.

EUREKA's IMPACT: AN EVALUATION

In 1992-93, the first year of implementing the second Medium Term Plan, the French Chair initiated 'The Evaluation of EUREKA's Effects', a wide-ranging evaluation to find out exactly what economic and social impact EUREKA projects have on Europe.

The international evaluation team, working totally independently of the EUREKA organisation, set out to assess how far EUREKA has come in accomplishing its objectives, to describe the achievements - and difficulties - experienced so far, and to draw lessons for industry and government. Using a combination of questionnaire and interview techniques, the study gained an accurate view of the EUREKA formula's effectiveness, and rendered proof of the value and success of the EUREKA formula.

Among the findings can be noted: 80% of participants expect a new product or process as a result of the EUREKA project and 40% have already achieved this. 76% of the firms boosted their technological ability, in particular on a world level. An overwhelming majority (around 90%) of partners found participation in a EUREKA project worthwhile or very worthwhile.

RUSSIA - A NEW EUREKA MEMBER

Another prominent result of the year was the continuously positive and fast EUREKA response to the development in Eastern and Central Europe.

Mr Saltykov, Russia's Minister for Scientific and Technological Policy, submitted his country's application to join EUREKA late in January. Vice-Minister Yakobashvili explained the request to the High Level Group in April, and less than three months later, the Ministerial Conference unanimously accepted Russia as a Member. Her membership became effective on 29 November when the last technical elements had been completed.

PROMOTIONAL ACTIVITIES

Throughout 1993, EUREKA organised a large number of brokerage events and conferences, more than in the years before. They were often co-hosted by the European Commission.

The goals of these events were: to promote the EUREKA Initiative; to identify challenges and trends for the future; to provide opportunities for industry and research to meet; to facilitate project generation; and to inform the public about EUREKA's aims and results.

The French EUREKA Chairmanship set up a series of industrial fora to encourage project generation in some areas considered as strategic by European industry. Each meeting included presentations of the challenges facing the industries, theme workshops and bilateral business meetings.

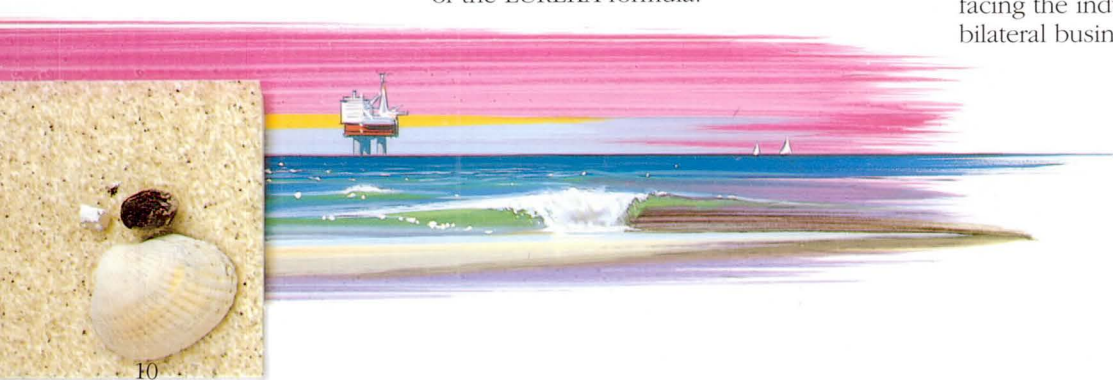

- From the Waste Management Conference (Angers, 22-23 September 1992), already reported in APR 92, 24 new projects related to biological, physico-chemical and thermal processes have arisen.

- “Factory of the Future” (Toulouse - 14-15 January 1993) saw 300 participants from 13 EUREKA Members and 7 European non-member countries (ENMC). Theme workshops covered the automobile, agrifood and electronics industries as well as new organisational approaches, concurrent engineering, etc. This event led to 43 new projects with a large SME and research centre participation and helped to define the position of European industry, also with regard to a possible cooperation with Japan, the US and others (IMS and CALS programmes).

- “Language Engineering” (Pont-à-Mousson, 16-17 February) joined 200 specialists from 14 EUREKA Members and 5 ENMC. Prepared in close cooperation with the European Commission, the conference was primarily devoted to establishing contacts between industrialists, researchers and technology transfer consultants in Natural Language Processing and focused on standards, interfaces and methodologies, linguistic resources, voice technologies, and the role of SMEs. Of last year’s 22 new projects in informatics, 3 are directly linked to the theme of this conference.

- “Automotive Industry” (Brussels, 11-12 March) had 240 participants from 12 EUREKA members and 5 ENMC. Organised together with the European Commission, it brought together relevant European industries and research institutes to stimulate co-operation between manufacturers, research centres and universities for developing traffic infrastructure and management systems, strengthening the ability of industry to satisfy environmental requirements and discussing technology standards. In 1993, 21 new cooperative projects, also involving SMEs and concerning clean engines, renewable oil and fuel, clean technology, waste processing and electric city car propulsion were identified.

Other brokerage events were organised by other EUREKA agencies and through various EUREKA “umbrella” networks, again often together with the Community:

- “MAST DAYS and EUROMAR Market Conference” (Brussels, 15-17 March) combined the forces of EUREKA’s EUROMAR umbrella and the Community’s MAST II (Marine Science and Technology) programme. Almost 400 scientists, industrialists and other decision-makers from 18 EUROMAR and 77 MAST projects presented their results, identified areas of common concern and discussed research strategies. Representatives of the Norwegian Trade Council and EKSPOMIL, the Research Council of Norway environmental R&D programme, presented discussions on marketing environmentally significant products and the relationships between ecology and economics.
- “Food Processing ’93” was arranged by the Netherlands EUREKA office in Zeist on 23-24 March. It brought together 143 researchers and industrialists from 14 different countries and resulted in around 40 project proposals. Participants attended a series of workshops on the various stages of food processing and held private meetings to discuss possible co-operative projects. 90% of the participants saw the event as a significant kick-start for their international activities.
- Together with the EUROENVIRON working group PREPARE and the German EUREKA Bureau, the German Environment Ministry hosted, on 29-30 March in Stuttgart, a two-day workshop on “Cleaner Production and Product Design for Electronic Consumer Goods” in order to tackle the problem of managing the increasing amount of computers, TV sets, etc., put out of use. More than 100 experts from ten countries participated and generated about 15 project ideas, some of which are now maturing into EUREKA projects.



- The “EUREKA and SMEs Seminar on Electronics” (Istanbul, 22-24 April) was organised by the Turkish EUREKA office and supported by the French EUREKA office and the EUREKA Secretariat with the aim of improving SME participation in the Turkish electronics industry. It included presentations by a variety of experts from various EUREKA countries as well as visits to relevant Turkish companies and to “Electronics 1993 International”, the first electronics industry fair in Istanbul.
- The “Diagnostics” brokerage event (Montpellier, 4-5 May) was hosted by the French EUREKA office with the support of the UK EUREKA Office and the Languedoc regional authorities. It brought together 145 participants from 12 EUREKA members and 3 ENMCs. The aim was to help Europe’s diagnostic industry, composed largely of SMEs, to make contact with each other, to focus on the fast-growing ‘diagnostic’ market and to receive information on relevant EUREKA projects and EC programmes.
- The “Second European Industrial Laser Forum” (Munich, 20-21 June) again combined the forces of EUREKA’s EUROLASER umbrella and the Community’s BRITE-EURAM programme and brought together 170 participants from industry and research to discuss progress and results in over 35 EUREKA, BRITE/EURAM and Community Bureau of Reference collaborative projects. It was connected to the large European Laser exhibition.

The EuroLaser Academy, an annual, one-month course held jointly by EUROLASER and the European Welding Federation (with financial support from the EC), was also launched. Attendees who pass the course’s optional examination will obtain a new degree: ‘European Laser Engineer’.

- “Fisheries Technology” was organised in Reykjavik on 13-14 September by the Icelandic EUREKA office and co-hosted by the European Commission. There were sessions on 9 different themes, each featuring technical presentations, discussions, poster shows and providing time for bilateral meetings, e.g. on selective fishing methods, quality control, environmental impact and the use of information technology and robotics.
- The “Celtic AGRIBUS Initiative” (Rennes, 14-15 October) on food processing involved five companies from Ireland and 20 from the Bretagne region. It was promoted by the French and Irish EUREKA offices and organised by the ANVAR Bretagne Delegation and the Irish Science and Technology Agency EOLAS. 12 individual lines of contact were established which, through continuous monitoring, will hopefully lead to EUREKA projects.

EUREKA EXHIBITIONS

On 24 June, the EUREKA exhibition “EUREKA - everyday innovation” was officially inaugurated by the EUREKA Ministers in Paris - La Villette and remained open for three months. Presenting 55 projects led by SMEs, large companies or research institutes, the exhibition provided a good illustration of the maturity of the European initiative and of its strong, vibrant character. Focusing on their impact on daily life, projects and results were presented under the headings: office and factory, health, transport, environment, cultural heritage, agri-food, communication, housing.

A large part of the exhibition was then shown in the European Patent Office (EPO) Branch in The Hague from 11-29 October, fitting into EPO’s programme of displaying outstanding examples of European technology and their patent background and implications.



EUREKA TECHNOLOGICAL AREAS

Marking the first EUREKA High Level Group meeting under Norwegian chairmanship, another EUREKA exhibition was opened in the Norway Information Center in Oslo in September to remain on display until February 1994. "EUREKA in Norway" presents a dozen projects with significant Norwegian participation.

EUREKA's profile at CeBIT'93, the world's largest information technology and communications fair, was high. There was a general EUREKA stand in the Strategic Research Centre and a major display devoted to EUREKA project 127 - JESSI (the Joint European Submicron Silicon Initiative), which, by its half-way mark, involves nearly 150 companies, universities and other institutions from 14 European countries.

The presence of EUREKA at the Esprit Days exhibition and conference in Brussels late in 1992 and at CIM Europe in Amsterdam in May demonstrated to industrialists and researchers the complementarity and synergy of EUREKA and the Community in Information Technology.

FOURTH INTERPARLIAMENTARY CONFERENCE

The French Parliament convened colleagues from parliaments of other EUREKA countries and the European Parliament to the fourth EUREKA Interparliamentary Conference on 6-7 May in Paris.

The parliamentarians welcomed the way EUREKA has worked in the last year, the preservation of its market orientation, the smoothness of its functioning, its bottom-up approach, the evaluation of industrial and socio-economic impacts, and the emphasis on environmental aspects such as waste management.

They recommended to improve conditions for SME participation, to evaluate large projects including EUREKA's impact on employment and external trade, to create more transparency and synchronisation of national support procedures and to continue openness towards Central and Eastern Europe.

In the following pages 658 projects are classified into 9 technological areas.

For each area a short overview of the EUREKA project activities is provided. It is not possible to list all the EUREKA projects in this Annual Project Report but a full list is available upon request from the National Project Coordinators or the EUREKA Secretariat (see addresses on pages 50-51).

SUPPORTIVE MEASURES

For the successful development of EUREKA projects and the implementation of their results certain "enabling conditions" may have to be met which are beyond the capabilities and influence of the project participants themselves.

In these cases the concept of "supportive measures" is an important one. The process is "bottom-up", beginning with the identification of the project's needs. However, fulfilling the conditions may require action from governments and international institutions, initiated and supported by EUREKA bodies.

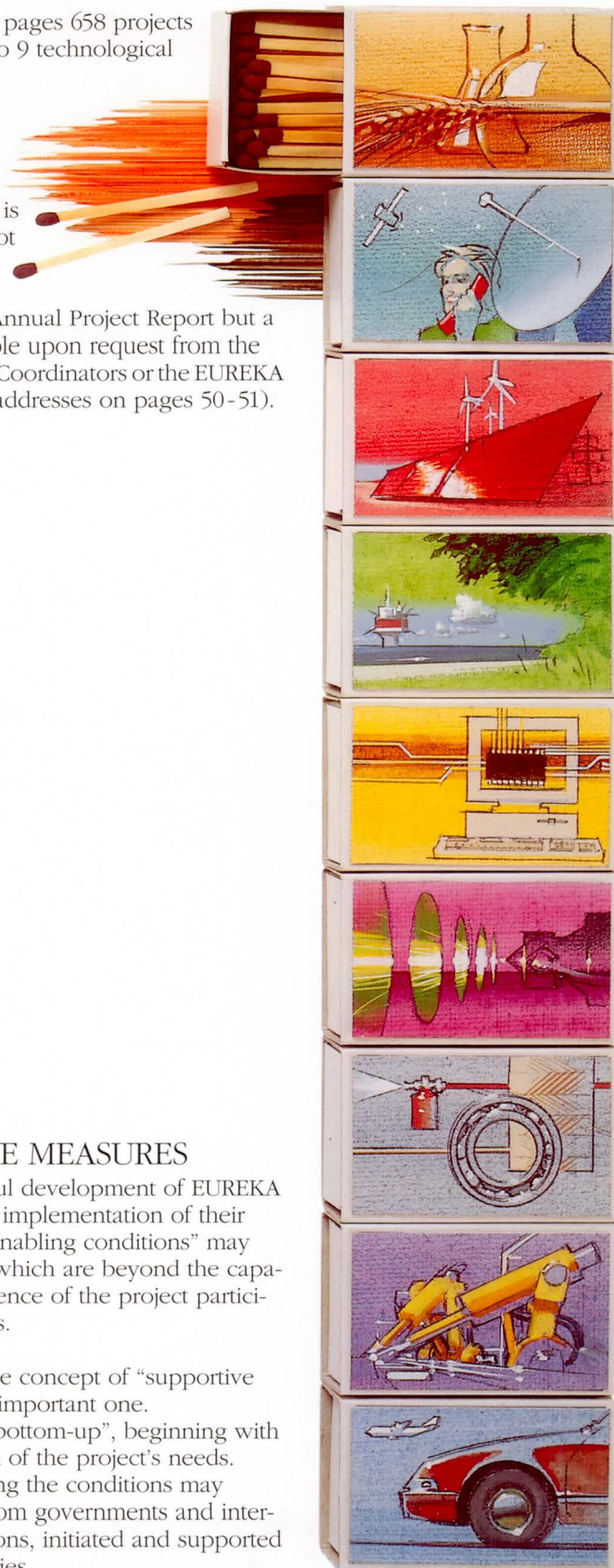

MEDICAL AND BIOTECHNOLOGY



Biotechnology - the technology of living matter - means different things to different people, evoking images as diverse as artificial organs, genetic engineering and crop management systems. It is not a specific industry or science like, for example, laser technology - it is more a multidisciplinary area, incorporating a wide range of techniques and tools. For this reason, European biotechnology researchers and industrialists have a lot to gain by combining their diverse skills in collaborative R&D.

This diversity is reflected in the Biotechnology portfolio. In this sector there are university laboratories and SMEs inventing artificial organs, agricultural industries developing better animal foods, research companies using 'biological sensors' to monitor the environment and much, much more.

Human and Animal Health

Improving human and animal health is, of course, a very important part of this sector. Of the 144 EUREKA Biotechnology projects either beginning, underway or finished, almost half are devoted to developing better treatments, diagnosis systems and surgical and other hospital aids.

The main treatments range from vaccines for combating infectious diseases to new drugs at the cutting edge of pharmacological and genetic research. Some projects are developing new methods to prevent cardiovascular disease, reflecting the concern over this Western 'plague', while others are working on treatments for cancer and tumours.

Further subjects are vaccines to prevent the transfer of disease from animals to humans, scavenging free radicals, improving wound healing and cures for meningitis, asthma and disorders of the central nervous system and digestive tract.

There are a total of 27 projects developing better diagnostic methods and tests, essential to both preventing and curing health problems. The importance of this growing field was recognised with the establishment of EU 798 - DIAGNOSTICS, an 'umbrella' for stimulating EUREKA diagnostics projects. The largest group are developing new diagnostic tools and methods, such as non-invasive measuring, disposable sensors and DNA probes, the second largest focuses on diagnosing specific diseases: cancer, AIDS, sexually transmitted diseases like gonorrhoea and syphilis, diabetes, allergies, and others.

The remaining diagnostics projects cover a wide range from imaging instruments and techniques to analysing human body motion in 3D.

Many projects concern improving surgery and other clinical activities in hospitals, developing new surgical tools, introducing information systems to aid medical decision-making, or improving hospital blood management systems. Others concentrate on orthopaedics or on developing implants, ranging from an artificial pancreas for diabetes sufferers to neurostimulation systems for paraplegics.

Improving Agriculture

Biotechnology, particularly genetic engineering, has the potential to introduce higher yielding, more disease-resistant crops and farm animals, speeding up a process which began thousands of years ago when farmers first started breeding animals and cross-fertilising plant species.

Of the 49 EUREKA projects on improved food production, 20 have been launched under the EUROAGRI umbrella since its inception in February, 1992.

They focus on the agri-food industry. Their range is as wide as the industry itself and includes new, environmentally-friendly technologies for extracting olive oil, innovative techniques for freezing fruits and vegetables and land-based fish farming. Non-food industries are also addressed.

Biotechnological Production Processes

The 24 projects in this area include many 'cutting edge' applications of advanced biotechnology. Some focus on improving protein production, mostly for pharmaceutical purposes, ranging from the computerised analysis of Nuclear Magnetic Resonance data for deducing protein structure to producing proteins through recombinant DNA techniques.

Others are developing new production methods and uses for enzymes, peptides, globin, emulsifiers and so on, mostly for applications in the pharmaceutical and food industries, or of laboratory instruments, biochemical re-agents, gene mapping systems, and diagnostic sensors.

Some projects deal with improving biological separation and cell culture processes for the production of a wide range of biological materials. One project aims to select, and produce on an industrial scale, bacteria to protect poultry from harmful human pathogens, such as salmonella.

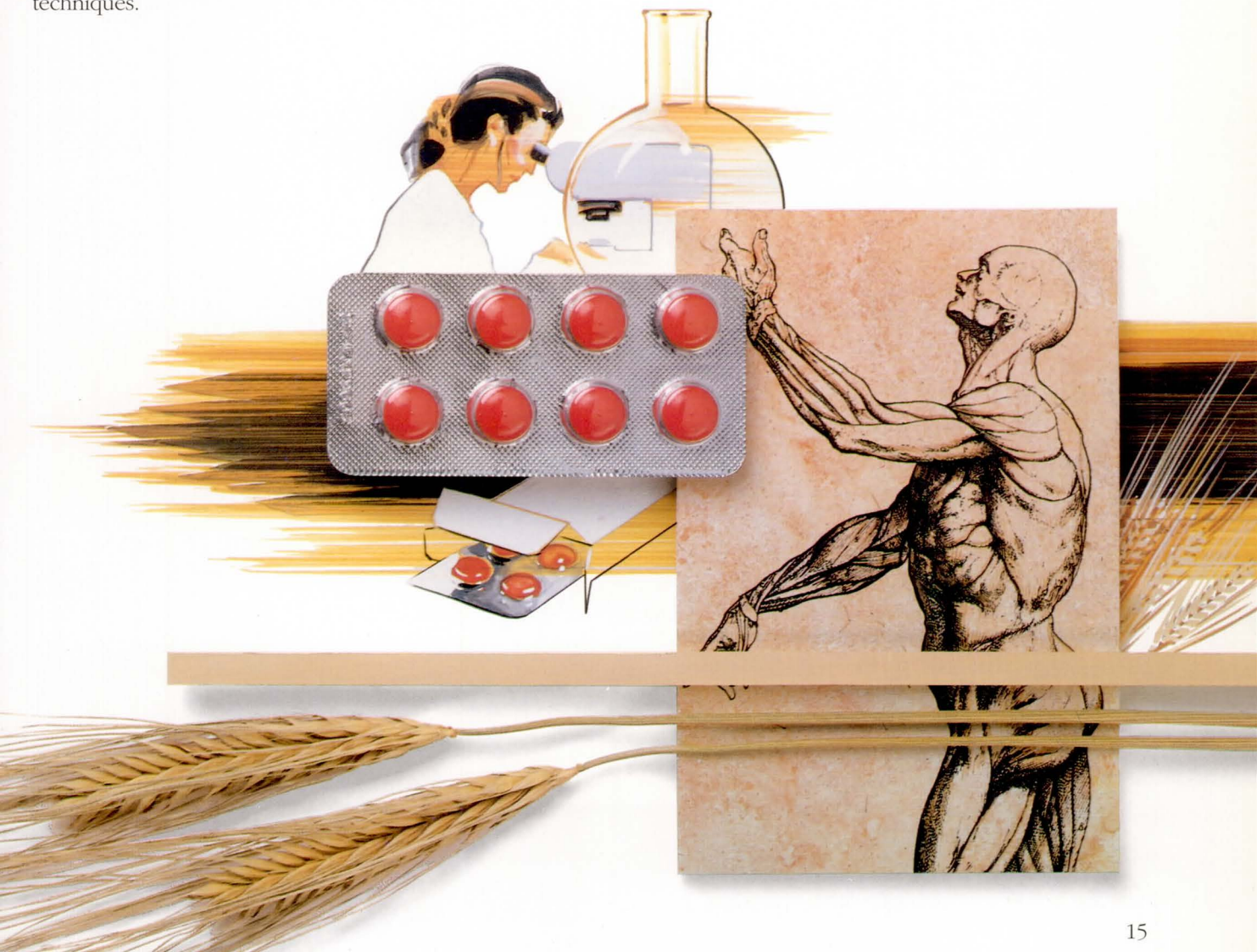

COMMUNICATION TECHNOLOGY

The world of communications is in a state of change. Its formerly distinct industries - radio, telephone, cinema, television, computer - are merging, making global communication more accessible and cheaper.

Advanced communications will help unite Europe and tap its potential. For this reason, Communication Technologies occupy a special niche in EUREKA's portfolio. Though the area is -with less than 40 projects - one of the smallest of the nine technology sectors distinguished in EUREKA, the average cost per project is the highest.

Telecommunications and Computers

Telecommunication networks are becoming increasingly powerful, able to handle much more than just telephone calls. A good dozen projects are devoted to developing either future networks or high-powered applications for them.

One is COSINE, led by the Commission of the European Communities until its completion in 1993. COSINE established an Open Systems computer network between European academic and industrial research centres, complete with electronic mail and directory services. A follow-up project, EUROCAIRN, was launched in 1993 by the European Commission.

Some network applications include computerised travel reservation systems, aircraft-ground telephone services, medical data transfer, enhancing cooperation among European aerospace firms and improved energy use management.

Other projects aim to increase the speed and accuracy of tomorrow's networks through optical systems and digital transmission codes, to develop open yet secure communication systems, or to investigate the effects of high-powered transmissions (TV, radio, radar) on civil aircraft electronic systems.

Media

The most important project in this area is the 850 MECU High Definition Television (HDTV) project, the second largest in the entire EUREKA portfolio. The 30+ companies and institutes are developing a new TV satellite transmission format with high definition, 'cinema format' picture, digital sound and multilingual options. In other projects, peripherals for increasing the acceptance of HDTV are developed.

Further projects in this sector concern the development of high definition graphics for film and television or research on standards for digitalising radio signals and improving terrestrial TV broadcasts.



ENERGY TECHNOLOGY

Our reliance on fossil fuels as energy sources has serious drawbacks: they pollute, they are finite, and they often have to be imported. These environmental and strategic concerns are creating new markets for cleaner and renewable energy sources and more rational methods of using energy. The 30 EUREKA projects in the Energy portfolio are trying to meet this challenge.

More Efficient Production, Generation and Use

21 projects have as their objective to improve the efficiency of extracting, converting or using traditional energy sources, for instance, through devising new technologies for off-shore exploitation, particularly of small, currently uneconomical fields, developing gas storage in rock caverns, or improving computer modelling of seismic data for use in hydrocarbon exploration.

Others pursue the upgrading of the efficiency of producing energy from the fuel once it is obtained, new power station designs, new gas turbines (for cars, ships and trains) or a more efficient mid-range diesel engine.

Finally, a number of projects strive for more rational and efficient use of energy through diverse technologies, ranging from the home (air conditioning, energy management) to industry (heat pumps and transformers, power supplies, cokemaking technology, etc).

Renewable Energies

Most projects in this sector focus on solar radiation, and all but one of these use photovoltaic (PV) cells, where light falling on specially prepared silicon creates direct electrical current.

The other solar energy project, PHOEBUS, concerns the development of a solar thermal plant. It has already proved the feasibility of the concept and now aims to build a 30 MW plant in Jordan in the mid-1990s.

Of the other renewable energy projects, the two announced in 1993 are 'biofuel' projects, one for converting waste biomass - wood-chips, sawdust or straw - into both electrical and heat energy, the other for developing forestry equipment for countries where wood chips are a significant source of energy.

One project is on wind energy, for developing and constructing pilot 3 MW wind power stations, using 80 m blades of carbon and glass fibre; the first plant was put into operation in 1993 in Wilhelmshaven, Germany.

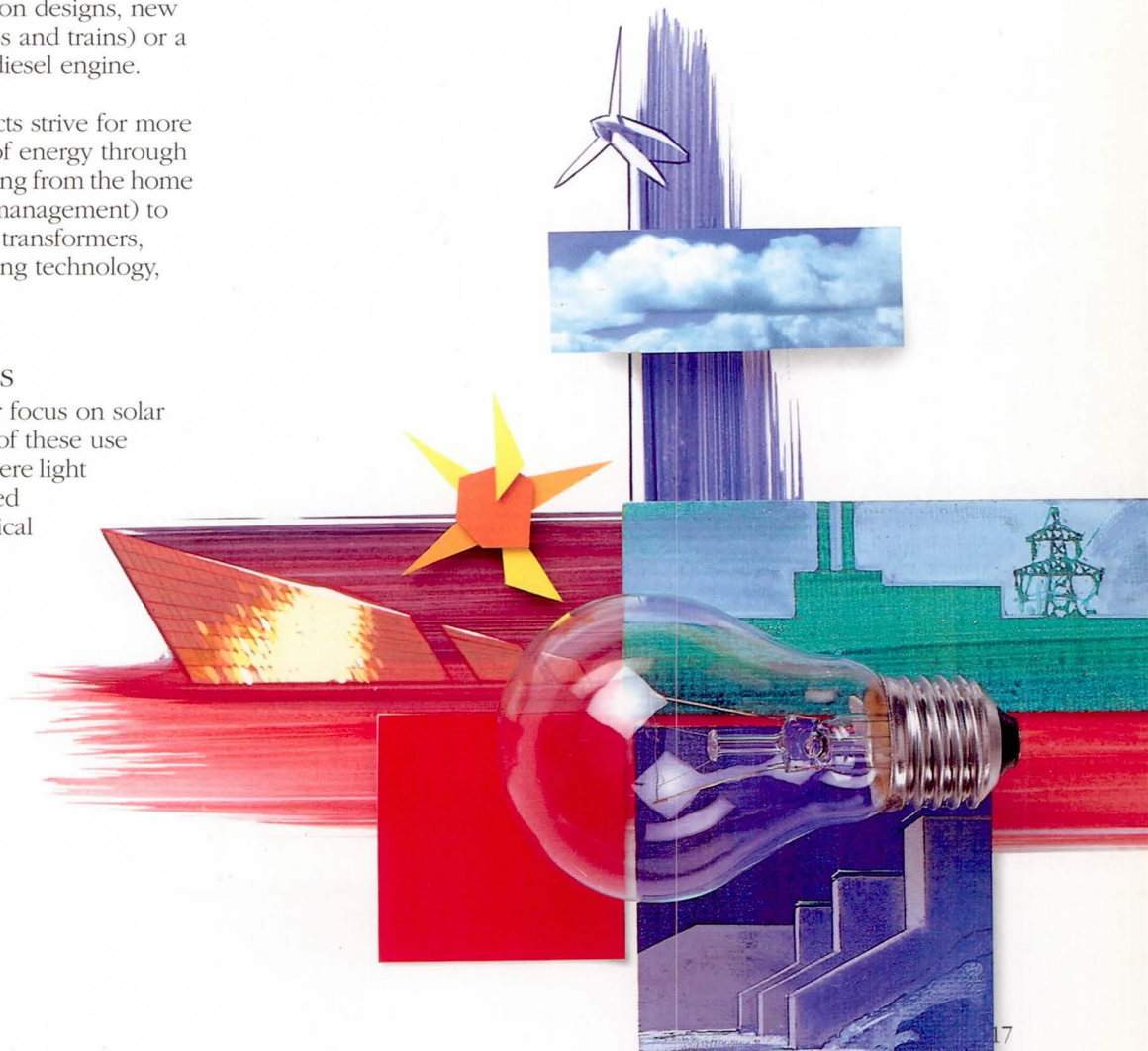

Environmental protection requirements are an opportunity, not a threat, for European business, opening new markets and spurring technological development. Given the intrinsically international dimensions of this sector, it is not surprising that European industry has found the EUREKA framework so suitable for environmental R&D. In fact, there are more projects in this sector than any other, clearly illustrating EUREKA's responsiveness to market demand.

Particularly prominent in this sector are three 'umbrellas' and a 'project cluster', which between them account for almost two thirds of the 166 projects.

Another characteristic is the high proportion of partners from non-member countries, reflecting the international importance of the environmental market, particularly in Central and Eastern Europe.

Cleaning Up Industry and Society

The EUROENVIRON umbrella, which focuses on Europe's terrestrial environmental problems, is making a great contribution to reducing environmental damage and risk from industry and society. Most of the 45 EUROENVIRON projects concentrate on industry: managing and detoxifying industrial waste, decontaminating polluted land, developing better industrial recycling systems and reducing the amount of environmentally unfriendly raw materials used. Many recycling projects involve turning waste, which would previously have been dumped, into new products, ranging from new packaging to electrical energy.

Projects also include 'greener' transport systems and tools for identifying highly polluting vehicles. New management systems for sewer networks and river and lake ecosystems are also being developed, as are better tools for preventing and dealing with environmental catastrophes.

Some 40 projects, not under the EUROENVIRON umbrella, are also designed to reduce negative environmental impacts of industry.

This includes safer solvents for industries ranging from dry cleaning to video cassette recorders, improving safety on offshore structures, reducing industrial noise pollution, developing atmospheric emission sensors, designing low-emission diesel engines, and advancing waste management, treatment, recycling, storage and incineration technologies.

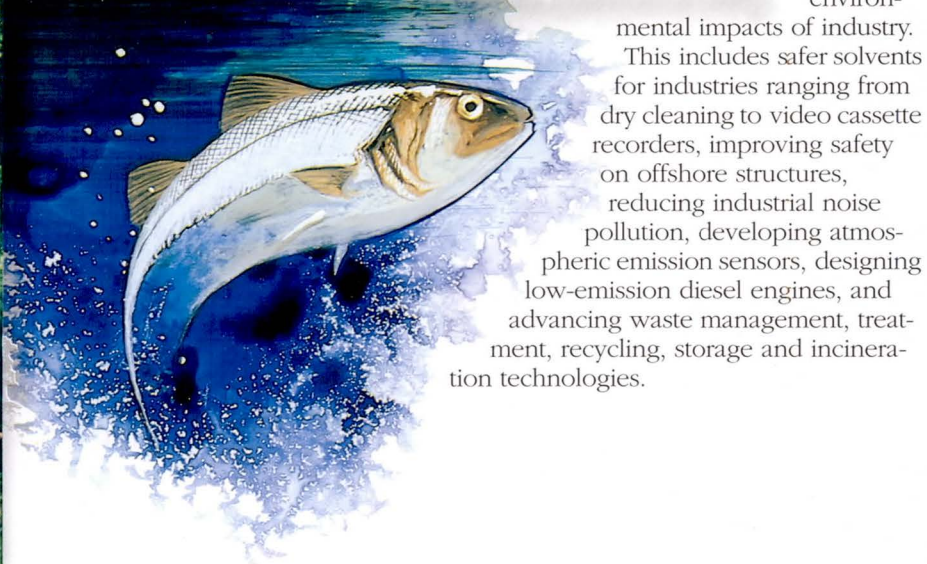
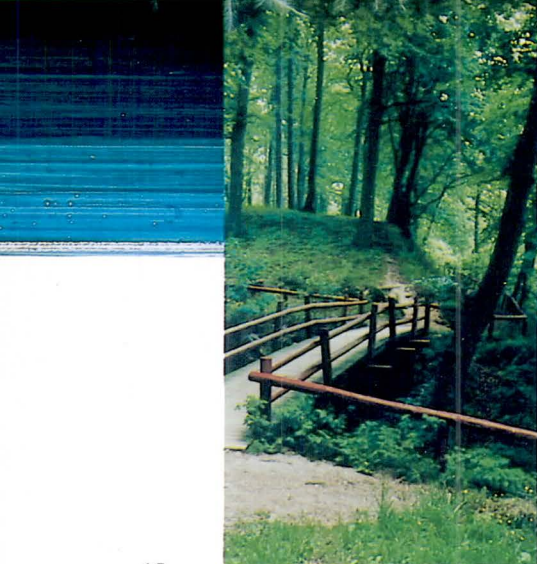

Environmental Monitoring and Management

Nearly all projects within the ENVINET 'project cluster' are developing tools for monitoring and managing different aspects of the non-marine environment.

New monitoring systems are a laser-based device for analysing the aerosol content of large volumes of air, an integrated helicopter-based package for monitoring air, ground and water pollution, and 2 sensor networks for evaluating the environmental impact of pollution on crops and forests. All projects include the associated data handling and analysis software.

Other ENVINET projects are writing environmental management software, some more general software tools and systems for diverse applications, some more specialised such as geographical information systems (GIS) for managing specific environments (water resources, river valleys, etc), permitting different data to be processed together and the prediction of likely effects of weather patterns or industrial and agricultural activities.

Non-ENVINET projects in this field include an airborne laser system for measuring plant health and EUROTRAC, a 200 MECU effort to increase basic knowledge in atmospheric science and develop better instrumentation for environmental research.

The Marine Environment

The great majority of the 26 projects on marine environment were launched under the EUROMAR umbrella which focuses on developing tools for monitoring this complex and important ecosystem.

Marine monitoring systems include aircraft-based sensor packages, software for analysing satellite data and a range of underwater platforms, sensors, buoy networks and imaging systems for analysing and surveying this environment from surface to sediment. Three EUROMAR projects are developing modelling and simulation packages, two more are concerned with the construction of prototype research vessels and mobile laboratories and another with marine data standards.

The non-EUROMAR projects in the area are devoted to prototype 'clean-up' vessels, wave attenuators, airborne water temperature sensors, a network of monitoring buoys, underwater acoustic cameras, cleaner harbour dredging techniques and an environmental risk assessment model.

Preservation

The EUROCARE umbrella aims to improve the preservation of ancient monuments and modern buildings through new materials, technologies, standards and sustainable environmental policy.

The 28 EUROCARE projects focus on preserving specific building materials, ranging from ancient wood foundations to historical granite monuments, on protecting and restoring ancient paintings and mosaics, on 'envelope buildings' for historic monuments, mapping archaeological objects in and on the seabed, preserving audiovisual material, controlling air pollution inside museums and recording cultural heritage on long-lasting optical disks.

EUROCARE also cares about modern buildings, for instance by studying the durability and service life of today's building materials and structures, reducing negative environmental impact of the building process and developing sensors to detect corrosion and monitor pollution deposition.



INFORMATION TECHNOLOGY

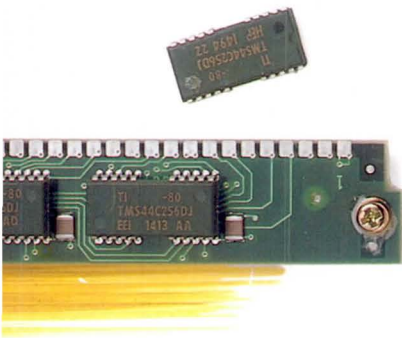

Information Technology (IT) now plays an integral part in our lives. We use IT products at work, we play with them at home, and more and more of modern society's infrastructure is becoming electronic.

The industry's turnover already amounts to many billions of ECUs, and demand grows seemingly without limit. Europe, although a major player in the field, faces very strong international competition.

The stakes are high. Apart from exploiting the enormous market in software and hardware, a healthy European IT industry will invigorate other areas. For this reason a competitive IT industry is vital for strategic, as well as economic, reasons. Small wonder, then, that the sector represents, financially speaking, half of the entire EUREKA portfolio, and involves a total of 114 ongoing and finished projects.

The Hardware Chain

There are two sides to the IT industry - hardware and software. The hardware industry is enormously complex, stretching from manufacturers of the equipment used to build Integrated Circuits (ICs), through the component manufacturers, who build ICs and other components for their customers, to the applications sector, who build everything from supercomputers to dishwashing machines.

'Vertically Integrated' projects, involving industries at different links of the chain, enhance the cooperation between supplier and customer and hence tend to be more successful.

The most important of these is EU 127 - JESSI, the Joint European Sub-micron Silicon Initiative, which combines EUREKA's 'bottom-up' principle with a pan-European strategic vision for a strong European industry from component production to product development. With a budget of 3,800 MECU, nearly 64% of the entire IT sector budget, JESSI is EUREKA's largest project, bringing together over 2,500 scientists and engineers from 150 companies and research institutes. The project divides their work into discrete subprojects, most of which are linked together in 'Clusters', ranging in subject from Broadband Communications to Lithography. Each Cluster features one very visible, commercially oriented 'Flagship project', with which the linked projects share milestones.

Apart from JESSI, 28 other EUREKA projects are developing better hardware, in particular for microelectronic components, through high-precision IC production processes such as electron beam and X-ray lithography, new engineering techniques in magnetic storage and chip interconnection, Gallium Arsenide technology and for specific applications, such as ASICs (Application Specific ICs) for image processing.

The other projects are devoted to computer peripherals, covering new sensor technology, new printing technology and better display systems.

Software

No less than three quarters of the projects in the IT portfolio are software-oriented. The largest group are developing software which itself is used to improve software production. The projects are using Computer-Aided Software Engineering techniques, developing programming environments designed to 're-use' existing software, and establishing 'software factories' for a variety of applications, software languages and operating systems, including CAD/CAM packages, ADA and LISP programs and parallel processing environments.

New software toolkits and methodologies for designing 'fuzzy adaptive control' systems, value-added distributed systems, decision support platforms for emergency management and open data exchange, among others, are on the way.

Other 'generic' software projects involve artificial intelligence, particularly expert systems and their use, the development of process simulators and models, machine-based linguistics which is a growth sector, visual quality assurance, the application of CAD/CAM software to industrial environments, the management of large-scale industrial sites, and improved decision-making in fields as diverse as medicine and welding.

A number of projects show the increasing interest in better management and operational control to help European industries to integrate new technology into their organisations.

This is the objective of EU 860 - INTO, the only umbrella in the IT portfolio but which is also related to production technology.



LASER TECHNOLOGY

Lasers can both improve the efficiency of manufacturing processes and perform jobs that are simply beyond other tools. At the moment, low-power applications range from eye surgery to bar code reading or compact discs. To reach the full potential of lasers for industry, power must be increased.

Laser development is therefore a major technological challenge with an important market potential. By combining research expertise with industrial experience, the 18 EUREKA projects are developing a variety of high-powered lasers tailored specifically to industry's needs.

The EUROLASER umbrella covers most projects in the sector. The 13 EUROLASER projects are concerned with the development and evaluation of high power industrial lasers and their application to a wide range of material processing tasks, emphasising their role as an integral part of advanced flexible manufacturing systems, as well as in other fields.

Laser Development

In most EUROLASER projects, more powerful, more efficient laser sources are being developed: CO₂-lasers, which can perform a wide range of cutting, welding and surface engineering tasks; excimer lasers of at least 1 kW (ten times current level) useful for high accuracy applications such as in micro-electronics; and solid state lasers which can deliver their beams via optical fibres. Research is also being carried out to explore the possibilities of CO-lasers which show great potential for working with plastics and ceramics as well as for medical applications.

Laser Applications

In 7 projects, 4 of them under the EUROLASER umbrella, developments include work on laser-based cutting, welding, surface and heat treatment of a variety of materials. Notable among these are the adaptation of copper lasers for industrial uses and the use of pulsed CO₂-lasers for processing granite and diamond. Work is also being carried out to develop laser lithography techniques for the microelectronics industry.

Laser Safety

As lasers become more widespread safety issues become more important. One such project concentrates on improving the safety of laser medicine, to both practitioner and patient, by developing better procedures, devices and standards, while the other, another EUROLASER project, addresses safety issues in the industrial application of lasers. The participants are identifying and controlling risks, elaborating training techniques and cooperating with standards organisation.



TRANSPORT TECHNOLOGY

With internal borders falling throughout Europe, the flow of goods and people will continue to increase. An efficient transport system is therefore essential to economic development. At the same time, it must meet environmental constraints.

Tomorrow's transport system must expand to meet demand and reduce negative environmental impact. This requires both developing new concepts of transportation and improving old ones. The 46 ongoing and finished EUREKA projects in the transport area are doing just that.

Road Vehicles and Infrastructure

Over half of the projects are designed to develop improvements in road transport. Fourteen are devoted to new cars or car components, with a strong emphasis on environmental issues. Developments include electric cars, pollution diagnostic systems, more environmentally friendly painting processes, recycling of cars and many novel car components.

Another 8 projects focus on road infrastructure. Most of them, including PROMETHEUS, the largest project in the whole transport sector, are developing 'transport telematics' systems which can make road transport safer, cleaner, more user-friendly and efficient through driver information and support, route navigation systems, vehicle, fleet and traffic management, road network flow analysis and other innovations. Two infrastructure projects are developing better road surfaces and improving safety in tunnels.

Four projects are oriented towards public transport systems, centred on more efficient buses and better system management.

Other Modes of Transport

One of the projects in this field is designing a road/rail system combining the best of both methods. Most of the others are solely rail-oriented, including lightweight metro trains and train components, silent and efficient linear motors, high-speed rail track and a new concept involving small, driverless vehicles travelling on a special rail network, suitable for metropolitan areas and airports.

Some projects address new aircraft, including amphibious and VTOL (vertical takeoff and landing) aeroplanes and a feasibility study into a lighter-than-air system for transporting heavy loads. Another non-road transport project is concerned with a high-power electric propulsion unit for marine vessels, ranging from passenger transport to arctic icebreakers.

Logistics and Management

Seven projects are concerned with improving transport efficiency through better management, be it through improved control of material flow throughout Europe, higher efficiency in the canal system linking seaports to inland factories, a network of road transport information systems, including an international database for freight and haulage companies, or mobile satellite-based location and communication systems.

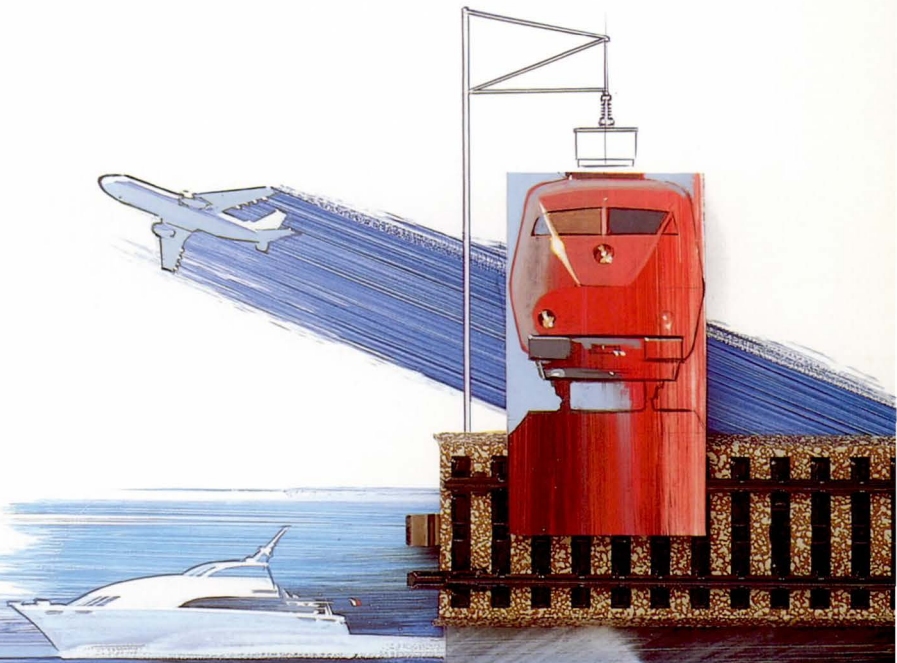

NEW MATERIALS

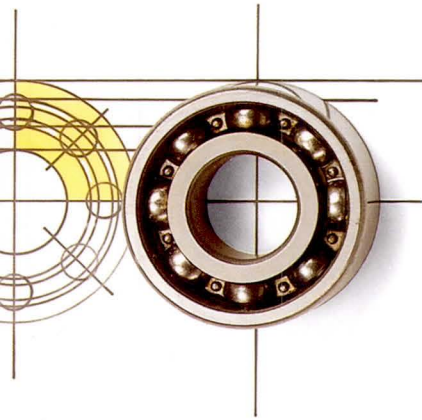

The mastery of materials has always been an indicator of technological sophistication, as the terms 'Stone Age', 'Iron Age' and so on show. Today, the science of materials involves not only the mastery of natural substances, such as aluminium and steel, but the production of completely new products.

This diversity is reflected in the 70 EUREKA projects in this area not to mention several others dealing with new materials which are classified in other areas. Apart from developing a wide range of new materials for an equally broad spread of applications, many projects concentrate on improving manufacturing and assembly processes.

New Materials and Applications

Almost half of the entire portfolio consists of projects concerned with applications for new materials. A large proportion focus on materials for car manufacturing, e.g. on ceramics for car engines, introducing non-metal materials into car bodies and the rest are improving the quality of steel car bodies and developing metal matrix composites for brake pads.

Other projects in the mechanical industry include centrifugal pumps, lightweight aircraft panels and diamond-like coatings for tools.

Materials development is the subject of another important slice of the portfolio. Work is being carried out on polymer and ceramic fibres for uses as diverse as medicine and concrete reinforcement or high-temperature applications (engine parts, heat shields, etc). A number of projects are devoted to the use of wollastonite for reinforcing polyurethanes and phenolic moulding composites or of aramid composites in truck tyres as well as for marine and offshore applications. The other projects are working on shoe leather substitutes, better clean-room clothing, aluminium matrix composites and an asbestos-free high-temperature board made of aluminium silicate.

The construction industry is increasingly featuring in projects working on new materials applications. Important themes include better materials for offshore construction, improved cement, aluminium and plastic pipe structures and new building construction systems.

Projects aiming at improving various industrial processes through advanced materials are concerned with, for example, environmentally friendlier ceramic anodes for aluminium production, more corrosion-resistant steel with less chrome content, and the recovery of precious metals from industrial waste.

Some projects are also concentrating on very specialised applications of new materials such as developing high energy permanent magnets through the use of rare earths and novel production techniques, producing superconducting magnets with magnetic field densities up to 50% greater than current limits for use in particle colliders, fusion energy, magnetic resonance analysis, etc.. Others are working on constructing very large optical telescopes by incorporating advanced metallurgical, coating and manufacturing methods, or developing new coatings, one by placing multiple, thin layers on surfaces so that it can be modified by electrical signals, another for electrically insulating metallic elements used in household appliances to create heat.

Two projects are developing processes which will both speed up and miniaturise electronic components. The first aims to replace printed circuit boards with a substrate onto which components can be surface-mounted, allowing them to be much more densely packed. The second is developing a polymer-based electro-optic modulator, which will convert electrical signals to light signals for tomorrow's optical communication network.

New Fabrication Processes

There are two umbrellas in this field: EUROSURF, which focuses on surface engineering, and EUROKLEBEN, which encourages R&D into adhesive joining technology. One EUROKLEBEN daughter project is already running while several others are in the preparatory phase.

The remaining projects developing new fabrication methods are split equally between those dealing with metals and those with other materials.

The former group is dominated by R&D into better aluminium products. Developments include stronger aluminium welds, strengthening aluminium through the merging of high performance aluminium inserts, medium pressure casting systems and honeycomb aluminium panels.

Non-metal fabrication projects involve the automated production of liquid silicon rubber products, alternative techniques for producing hard road materials for the developing world, joining metals and ceramics using ion beam treatments and laminating non-woven textiles.

Testing Equipment, Design Codes and Standards

New materials and processes invariably need new standards and design codes if they are to be used by industry.

There are two projects concentrating on establishing design codes, one for polymeric composites and the other for high strength steel welding under demanding conditions.

Five projects are aimed at developing new testing methods and equipment, ranging from ultrasound scanning of material interfaces to portable neutron radiography for industry.

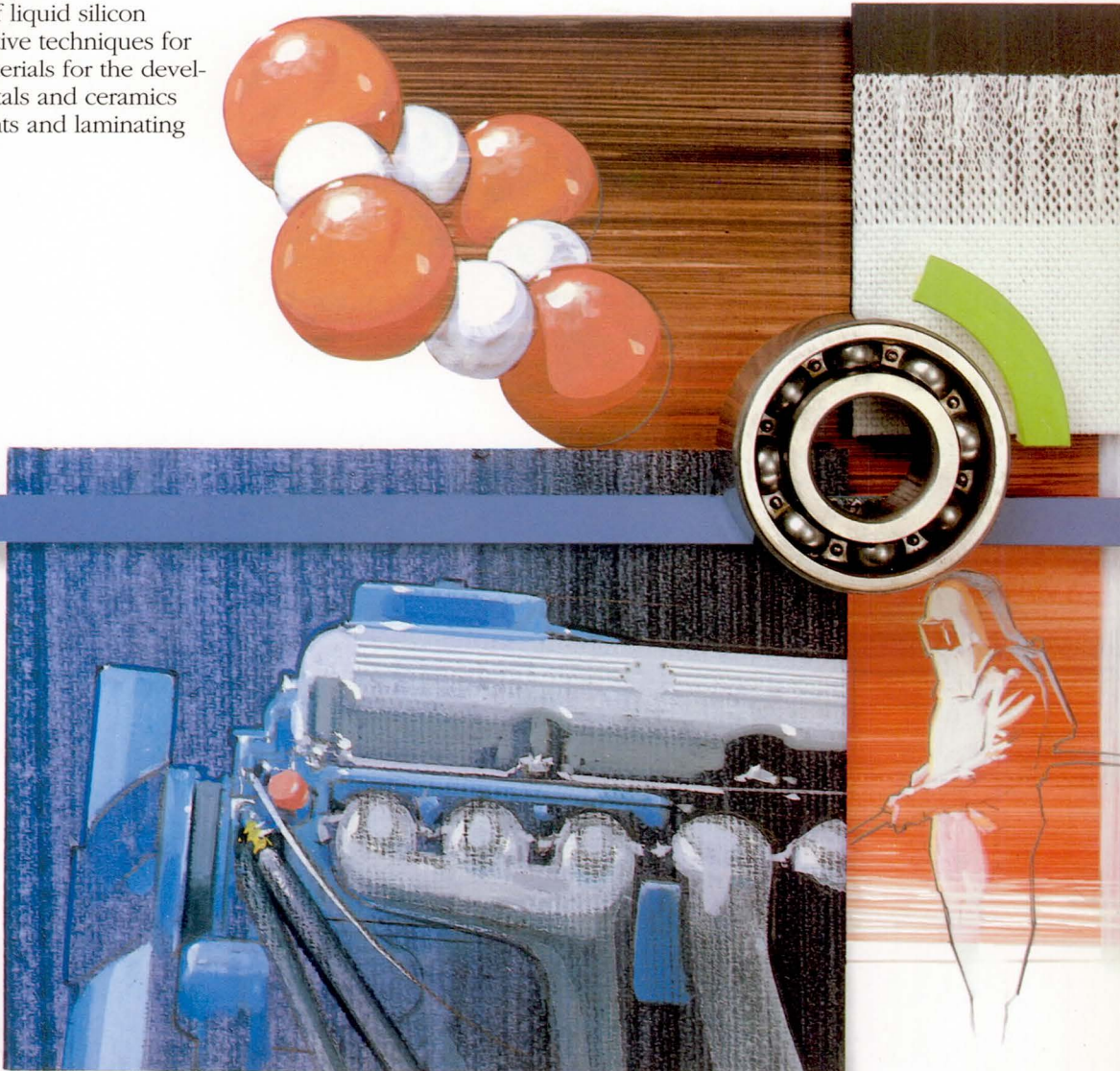

ROBOTICS AND PRODUCTION AUTOMATION

Europe's manufacturing industry faces stiff competition from other technologically advanced countries and from countries benefiting from substantially lower labour costs. The answer to these challenges is the same: advanced manufacturing technology.

The key technology is flexible assembly, allowing factories to produce economically small batches of a wide variety of products to match changing market demands, a far cry from yesterday's mass-production lines, churning out thousands of identical products.

Developing these factories will require an enormous research effort, stretching from the design stage to the shopfloor. Accordingly, the 146 ongoing or finished EUREKA projects in this field are working in areas as

diverse as computer-aided design and manufacturing (CAD/CAM), artificial intelligence, robot sensors and personnel management. Together, they are meeting the challenges to keep European manufacturers competitive on the world market.

Advanced Manufacturing and Factory Automation

The FAMOS umbrella, with many of its 60 daughter projects being dedicated to promoting flexible assembly R&D, plays a major role among the 75 projects in this area.

For example, all 28 projects developing flexible manufacturing and automated assembly systems were launched under this umbrella, most of them focusing on specific industries, from household appliances to electronic and mechanical components. All the projects have similar aims: to improve assembly line productivity and product quality through techniques such as on-line quality control, Just-in-Time planning and greater flexibility of both products and production methods.

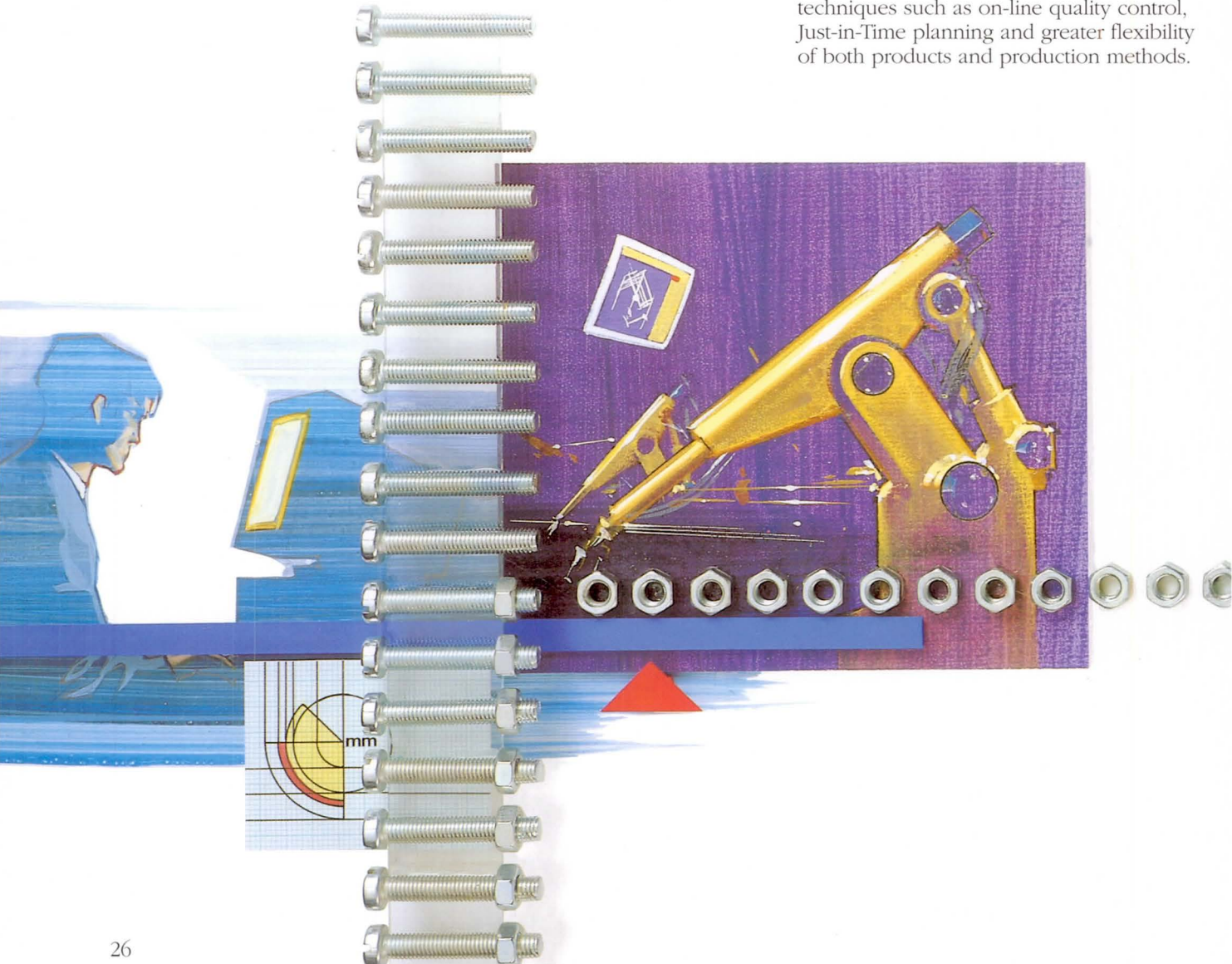

Around a quarter of the 27 projects for improving existing production technologies are FAMOS projects. Industries targeted here range from food to electronics.

Both the Computer Aided Design and Engineering (CAD/CAE) as well as about half of the Computer Integrated Manufacturing (CIM) projects were also launched under FAMOS. The CAD/CAE projects aim to improve machine tool assembly and leather design and cutting through advanced computing, while the CIM projects incorporate all aspects of advanced manufacturing into a single integrated system.

Enabling Technologies and Special Developments

Typical enabling technologies and developments are concerned with sensors, software and special tools and components, both for specific industries (e.g. oil/gas, textile, paper) and of a more generic kind.

In nearly twenty projects, software is being developed, including a cluster of five projects developing around 80 software modules for aircraft manufacturers. FAMOS projects are working on software for real-time control and scheduling, information management, and flexible assembly cell control. Non-FAMOS-projects are concentrating on packages for specific industries.

Among the projects aiming at specific tools and components, the main objectives are, inter alia, new valve systems for power transmission, wooden surface treatment technology, systems to control cranes and other heavy machinery, and an artificial vision system for autonomous vehicles.

Robots

Of the 24 projects in robot development, a third are oriented towards the use of robots in environments difficult or dangerous for humans such as for underwater craft including submarines, remote-controlled vehicles, fully autonomous installing, inspecting and repairing hardware or long-range subsea surveys.

In other projects, robots are to be developed for routine surveillance and emergency functions in dangerous industrial sites or for the exploration of planets.

Equally beneficial are projects to develop robots for the building and construction industries, typically for replacing human labour in dangerous work such as on tall buildings or in lifting heavy loads.

Other projects focus on farming, on developing a driverless tractor and robots for handling citrus fruit and roses, on introducing automated fish handling systems on trawlers, on a remotely controlled camera crane, on robots for service industries which are safe and sophisticated enough to interact with people in public environments such as hospitals.

Maintenance, Quality Assurance and Organisation

The daughter projects of the MAINE umbrella are making 'benchmark studies' of maintenance issues and developing monitoring and diagnostic systems to reduce downtime and maintenance costs as well as enhance safety, efficiency and product quality.

Six projects focus on quality assurance and management software, some of them under the FAMOS umbrella, with emphasis on new systems which will allow operators to monitor product and process quality throughout their operations and to comply with standards.

A new umbrella, INTO, was launched in 1993 to help industry better integrate their organisation, people and technology structure. Its first daughter project is developing a management aid for analysing inter-company relationships to help collaborative efforts. Another project aims at a methodology for integrating a company's managerial and production concerns.



STATISTICAL TABLES

FINANCIAL SIZE OF PROJECTS

Number of ongoing projects by area

Project Cost (PC) in MECU

	Total number of projects	BIO	COM	ENE	ENV	INF	LAS	MAT	ROB	TRA
PC ≤ 1	134	26	2	6	41	12	2	16	24	5
1 < PC ≤ 3	167	37	10	6	39	15	2	22	22	14
3 < PC ≤ 5	94	19	-	1	29	14	-	12	14	5
5 < PC ≤ 10	109	23	6	2	23	17	2	6	27	3
10 < PC ≤ 20	61	12	1	4	11	8	4	2	15	4
20 < PC ≤ 40	49	3	3	4	5	12	2	3	12	5
PC > 40	43	4	4	5	6	10	5	2	5	2
Unspecified	1	-	-	-	-	-	-	-	1	-

FINISHED EUREKA PROJECTS

Number of projects by area

	TOTAL	BIO	COM	ENE	ENV	INF	LAS	MAT	ROB	TRA
Number of projects	112	18	8	3	12	26	1	9	26	9
Total cost (in MECU)	1636,5	164,3	538,5	152,5	59,7	308,3	3,7	38,6	194,5	175,8

PLANNED PROJECT DURATION

Number of ongoing projects by area

Project Duration (PD) in Months

Total number
of projects

		BIO	COM	ENE	ENV	INF	LAS	MAT	ROB	TRA
PD ≤ 24	128	15	5	6	40	11	1	11	29	10
25 < PD ≤ 48	331	65	12	12	77	52	3	32	58	20
49 < PD ≤ 72	139	32	3	8	29	18	8	17	18	6
PD > 72	60	12	6	2	8	7	5	3	15	2
Unspecified	-	-	-	-	-	-	-	-	-	-

EUREKA PROJECT PROPOSALS

Number of projects by area

TOTAL

	TOTAL	BIO	COM	ENE	ENV	INF	LAS	MAT	ROB	TRA
Number of projects	103	16	2	7	18	20	3	9	13	15



STATISTICAL TABLES

PARTICIPATING ORGANISATIONS IN ONGOING PROJECTS

Number of organisations

Member	Industry		Research		Government/ Nat. Bodies & Others	Total
		of which SME		of which University		
Ⓐ Austria	64	22	26	14	10	100
Ⓑ Belgium	80	33	29	22	3	112
Ⓒ CEC	0	0	5	0	2	7
ⒸH Switzerland	82	47	53	37	12	147
Ⓓ Germany	306	89	196	100	17	519
ⒹK Denmark	57	19	25	10	9	91
Ⓔ Spain	156	60	64	33	12	232
Ⓕ France	458	135	169	54	25	652
ⒻN Finland	119	44	24	9	9	152
ⒼR Greece	23	9	18	12	2	43
Ⓗ Hungary	11	5	9	2	2	22
Ⓘ Italy	220	38	107	57	10	337
ⒾRL Ireland	8	2	9	9	2	19
ⒾS Iceland	9	9	5	1	1	15
Ⓕ Luxembourg	4	0	0	0	1	5
Ⓖ Norway	82	30	39	7	15	136
ⒼL Netherlands	221	82	64	32	13	298
Ⓖ Portugal	25	6	38	18	11	74
Ⓔ Sweden	123	52	36	14	16	175
ⒹR Turkey	4	2	5	4	0	9
ⒼK United Kingdom	267	69	103	64	30	400
Non-member countries	14	4	23	4	1	38
Total	2333	757	1047	503	203	3583

JOINT PARTICIPATION IN ONGOING PROJECTS

Ⓐ Austria																					
15	Ⓑ Belgium																				
9	7	ⒸⒹ CEC																			
23	17	6	ⒸⒹ Switzerland																		
44	29	14	38	Ⓓ Germany																	
18	18	9	15	34	ⒹⒻ Denmark																
23	30	11	16	59	23	Ⓔ Spain															
27	51	15	42	91	36	83	Ⓕ France														
20	18	10	16	42	27	26	41	ⒻⒼ Finland													
12	11	10	8	21	12	19	22	15	ⒻⒼ Greece												
5	5	3	2	6	2	6	6	3	4	ⒻⒼ Hungary											
32	28	12	22	74	30	74	95	32	24	5	ⒻⒼ Italy										
9	5	5	5	13	10	11	11	10	5	1	15	ⒻⒼ Ireland									
2	1	2	1	2	4	3	3	2	2	0	2	2	ⒻⒼ Iceland								
3	3	2	3	3	3	3	4	3	2	0	3	2	1	ⒻⒼ Luxembourg							
19	13	13	18	35	25	29	33	34	14	4	28	11	5	2	ⒻⒼ Norway						
28	40	12	24	65	34	49	68	35	15	4	53	12	2	4	39	ⒻⒼ Netherlands					
10	11	7	7	21	13	33	24	15	14	4	21	10	2	2	15	16	ⒻⒼ Portugal				
28	19	13	24	55	34	34	40	48	14	5	38	12	2	3	49	39	16	ⒻⒼ Sweden			
4	3	5	3	5	5	6	6	6	6	3	5	3	1	0	6	6	5	6	ⒻⒼ Turkey		
34	26	12	23	65	41	57	84	40	18	6	55	13	5	3	34	58	21	41	7	ⒻⒼ United Kingdom	
6	6	4	3	17	7	8	15	6	7	3	13	2	1	1	5	11	6	8	2	9	Non-member countries

REINFORCING SYNERGY WITH THE EUROPEAN COMMUNITY

The European Community has been a member of EUREKA since its inception and contributes to its evolution.

The Community R&D programmes and EUREKA converge towards the same goal: the reinforcement of the technological bases and the improvement of European industrial competitiveness.

The Community participates in EUREKA through its own research capacity (Joint Research Centre), R&D programmes and financial facilities as well as through the creation of a suitable environment for technological cooperation and the development of enterprises.

At project level, Community R&D results are taken into account in EUREKA projects.

This approach, together with two-way transfers of information, allows an effective distribution of tasks and the avoidance of unnecessary duplication of effort. The Commission funds many EUREKA projects directly or indirectly and participates in some of their management committees.

The Commission supports the implementation of supportive measures, for example standardisation and the valorisation of R&D results (e.g. via the VALUE programme) and participates in EUREKA brokerage events, conferences, workshops etc.

Certain EUREKA projects with a high standardisation content are transferred to Community programmes, either totally or in part.

Developments in and since 1992, both in the Community and in EUREKA, have opened up new prospects and offered opportunities to enhance the synergy between Community and EUREKA actions.

During the French Chairmanship, in October 1992, the High Level Group had approved a set of principles for reinforcing the interaction between EUREKA projects and Community programmes.

This orientation was confirmed by the Edinburgh summit in December 1992.

The EUREKA Ministerial Conference on 24 June 1993 in Paris elaborated this further and expressed the wish that it be incorporated in Community R&D policy. The Council of the European Union included it in its common position for the 4th Framework Programme for RTD as follows:

"EUREKA will remain the principal vehicle for supporting RTD activities which are nearer to the market. The synergy between the Community's activities and EUREKA will be improved. To this end, while preserving the specific features of each framework, the following objectives will be pursued: flexible and active cooperation between representatives of EUREKA projects and of Community projects through regular exchange of information, guidance of proposed R&D projects towards the most appropriate framework and improved interaction between Community policies and EUREKA projects, in particular through greater Community participation in these projects whilst respecting Community procedures."

1993 has already seen the evolution of this reinforced EC-EUREKA synergy from pilot experiments to concrete daily joint actions, such as:

- Reinforcement and more intensive use of the flexible network of Community programme managers and EUREKA project coordinators has led to better, broader and timelier exchange of information.
- The joint organisation of conventions and promotional events, of which many examples are given on pages 10 to 12, has facilitated the orientation of projects towards the most appropriate framework and led to better complementarity.
- A joint analysis of 25 recent projects was carried out in meetings between EUREKA coordinators, Commission experts and industrialists concerned, leading to the definition of concrete joint actions for each project examined.

The statements of the EUREKA Ministerial Conference and the common position of the Council of the EU for the 4th Framework Programme reinforce the basis for future actions.



RELATIONS WITH NON-MEMBER COUNTRIES

When the EUREKA Ministerial Conference met in Paris in June 1993, ministers from the 20 member countries and a commissioner from the European Community welcomed the Russian Federation as a future member of the EUREKA Initiative.

This new membership, which took effect on 29 November 1993, underlines EUREKA's ability to respond in a flexible and fast way to the needs of both East and West European industrial research to cooperate across borders and to be competitive on the world market.

The EUREKA Ministerial Conference had already stated in Rome in June 1990 that advantage should be taken of the unbureaucratic EUREKA rules to favour increased and earlier cooperation with companies and research institutes from Central and Eastern Europe. This was followed by "The Hague Statement", adopted by the Ministerial Conference in The Hague in June 1991.

It envisaged an extended information policy, improved networking and a flexible application of EUREKA rules in order to enable entities from European non-member countries to participate in EUREKA projects at an early stage.

National EUREKA Information Points were established in most of the Central and Eastern European countries during the Finnish Chairmanship.

The Finnish-led activities culminated in Hungary being unanimously accepted by the Ministerial Conference in Tampere in May 1992 as the first new EUREKA Member since 1986.

The French Chair undertook extensive efforts to increase the exchange of information and relations with the National Information Points set up in 12 countries of Central and Eastern Europe, in particular through an information meeting on data required for project proposals and on project appraisal.

The French Chairmanship also led EUREKA delegations to Sofia and Kiev in December 1992 and January 1993.

They received valuable information on the local potential for participation in EUREKA projects, presented EUREKA to the host countries and gave detailed advice on how to participate in EUREKA projects.

Representatives of the French Chair, the incoming Norwegian chairmanship and the EUREKA Secretariat supported two EUREKA information days organized with the National Information Points of Rumania - on 20 April in Bucharest - and of Russia - on 3 June in Moscow.

In June 1993, the Ministerial Conference, announced participation of a further 16 companies and research institutes from Central and Eastern Europe in 9 EUREKA projects and welcomed the work programme presented by the Norwegian Chair which highlights the further development of the relationship between EUREKA and Central and Eastern Europe.

Towards the end of 1992, closer relations were also established with the Iberoeka Programme, an initiative modeled after EUREKA and supported by about 20 Latin-American countries, Portugal and Spain. In October 1993, EUREKA representatives, (Norwegian Chair, several NPCs and the EUREKA Secretariat) played an active role in an Iberoeka seminar in Santa Cruz de la Sierra (Bolivia) under the heading "Management and Evaluation of Innovation Projects".

Also for other non-member countries, EUREKA procedures offer flexible, diversified and pragmatic ways for R&D cooperation on a case-by-case basis.

Thus, 32 companies and research institutes from 12 non-member countries are already taking part in 21 EUREKA projects, another 18 entities from the Russian Federation having joined 12 projects before Russia became a Member.

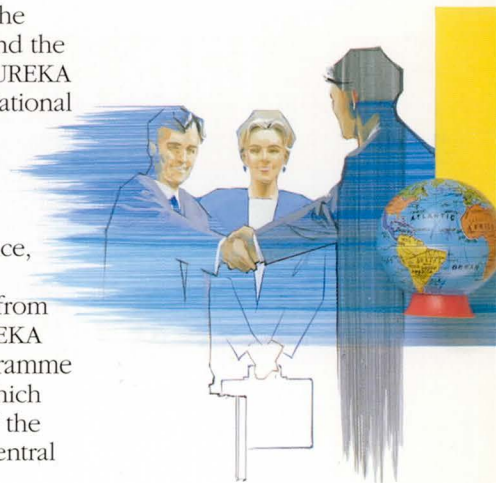

FINISHED PROJECTS



The real fruits of the EUREKA Initiative are beginning to appear: Finished projects. By November 1993 there were 112 such projects, exactly half of which finished in the preceding 12 months.

This sudden rise is a result of EUREKA's early development: while the first few years were used for getting EUREKA 'off the ground', the Initiative has really taken off, in terms of project generation, since the end of the 1980s. As a large proportion of the projects are under 4 years in duration, it is natural to see a surge of finished projects in the early-mid 1990s (see Graph 1).

New products resulting from these projects range from better animal feeds to prototype lithography machines for producing more powerful integrated circuits. Other results include patents, feasibility studies, standards and environmentally friendlier industrial processes.

In the few years since the 1989 Ministerial Conference, the number of ongoing projects has risen from around 210 to over 650.

The 112 finished projects, therefore, are only the first signs of an approaching flood of European high technology products, processes and services on the market.

In terms of estimated cost, number of participants, or average duration, the 112 finished projects are no different from the other 670-odd ongoing projects.

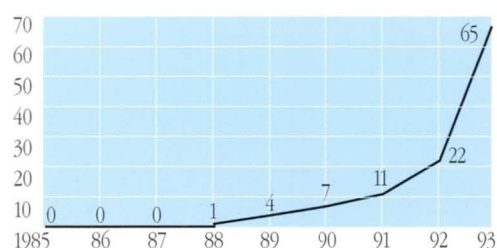

Graph 1

There is therefore every reason to expect the number of finished projects to keep rising, as the more recently announced projects are similar in profile to the first few hundred from which most of today's finished projects come. However, there is one characteristic that does set these finished projects apart from the rest of the portfolio: SME participation.

SMEs:

A Clear Market Orientation

"All SME-only projects (in the sample) were product-oriented ... SMEs are more likely to have already achieved a product or process ... this effect is stronger when independent SMEs are considered..." - Evaluation of EUREKA Industrial and Economic Effects, 1993.

This Evaluation, carried out during the French Chairmanship (see page 10) on a representative sample of ongoing projects, clearly identified both the importance of SMEs for EUREKA and of EUREKA for SMEs.

It shows that projects with SME partners are more product-oriented and seem to produce results more quickly than others.

In fact, the rate of SME participation in the 112 finished projects is slightly higher than in the portfolio as a whole. While there are SMEs in less than 60% of all ongoing or finished EUREKA projects, the figure for the finished projects alone is 64%.

Even more significantly, 40% of those 112 finished projects were led by SMEs, while SMEs only lead 31% of all EUREKA projects.

Technological Areas:

A Demographic Analysis

Although the already finished projects resemble the entire portfolio in global terms, their percentage of all projects varies from one Technological Area to the other. For example, the 112 finished projects account for 14% of the entire EUREKA portfolio, but they make up for over 20% of all the projects ever announced in Information and Communication Technology, with Transport and Robotics and Production Automation not far behind.

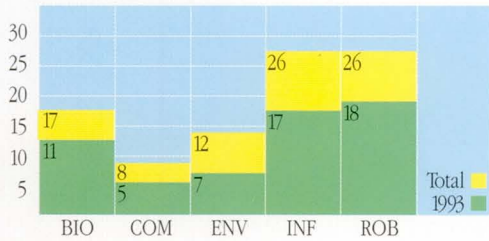

Graph 2

These are the areas in which a large number of projects were generated early in the Initiative's history; so it is perfectly natural that they dominate the finished projects statistics today. By the same logic, the next few years should see a sharp rise in finished projects in Environment and Bio/Medical Technology, mirroring the rapid growth in these areas in the early 1990s (see Graph 2).

Furthermore, the two areas with the highest proportion of finished projects are associated with the electronics industry, where product turnaround times are shorter than average.

Lastly, it is interesting to note the success of the FAMOS umbrella.

Of the 26 finished projects in Robotics and Production Automation, almost half were launched under this umbrella which concentrates on flexible assembly systems. It appears that this umbrella's policy of encouraging vertically integrated projects is bearing fruit.

Conclusion

The sharp rise in finished projects indicates, above all, that the EUREKA formula satisfies European industry's needs.

The many hundreds of projects launched in the last few years are essentially similar - in terms of size, cost, structure and partnership - to those launched earlier, so the trend described above should continue.

This will mean more and more projects reaching their conclusion in the coming years, particularly in the Medical and Biotechnology and Environment areas. They should result in a range of new products and in the development of improved manufacturing methods.

In addition, every project brings research centres and industrialists from all over Europe together in collaborative, market-oriented R&D.

In doing so, they are fulfilling EUREKA's long-term goal: a Europe-wide scientific-industrial community, ensuring European competitiveness on the world market.



SELECTED PROJECTS

In this section, 12 individual EUREKA projects are presented as examples of what EUREKA projects actually involve. The projects have been selected to give a taste of the wide variety shown by EUREKA projects. This variety is reflected in the technological span of the projects as well as the geographical distribution of the participants.

Furthermore, the wide range of project participants, from multinational corporations to very small companies and from dedicated production industries to university institutes, serves to prove that EUREKA really does work as a catalyst in making European industry and science work together to improve European competitiveness.

In fact, although the Initiative is only eight years old, EUREKA-developed products, processes and services, some of which can also be found in this section, have already been successfully launched on the market.



GROWING ANIMAL CELLS ON A LARGE SCALE

Many processes in biotechnology, such as vaccine manufacture, molecular biological research and the production of new ranges of pharmaceuticals, depend on growing living cells under precisely controlled conditions. With the astonishing developments in both genetic engineering and new therapeutic products, international interest in growing animal cells reliably is rapidly increasing.

A major problem with existing cell culture technology is the variable quality of the liquid medium, which provides the growing cells with all the nutrients and growth factors they need. Whilst these problems can be overcome on a laboratory scale, large scale production of mammalian cells by such methods are both costly and difficult to standardise.

CELLMED, EUREKA Project EU 123, aims to simplify the culture medium used to grow mammalian cells on a large scale. The new media formulated by this French, Dutch, Spanish and British partnership will be purer, giving greater consumer safety, better performance, and a reduction in medicine process costs.

Users basically want to be able to mix a few chemicals off the shelf to obtain their medium. So far this is impossible because different animal cells have different nutritional requirements. Many cell lines will grow satisfactorily only when an otherwise simple medium is supplemented with natural products, which are difficult to obtain. Demand for these products is increasing by 25% per year.

The project combines the partners' talents in many technologies, from protein separation technology (Advanced Protein Products (APP), INSERM) to media formulation (IBF, Diosynth). In addition, Bertin & Cie are designing the processing plant for cell culture, IBF Biotechnics (a subsidiary of Sepracor SA) and APP are providing 'sales muscles' to commercialise the new products and Diosynth, RIVM and Laboratorios Sobrino all have extensive market knowledge.

As a result of this collaboration, six potentially useful new products are ready to be tested in an extensive cross-laboratory trial. This trial will allow all the collaborators to evaluate the new media, as well as the cell lines for which they are formulated. These cell lines are to be used for therapeutic products, vaccines, and for diagnostic purposes in animals and humans.

EU 123

*Medical and Biotechnology
Acronym: CELLMED*

*Title: Media for large scale
mammalian cell growth
and maintenance
Announced at:
Copenhagen, 1988*

Participants:

France:

*INSERM /IBF Biotechnics
S.A./ Bertin et Cie*

Netherlands:

RIVM / Diosynth B.V.

Spain:

*Laboratorios Sobrino S.A./
Laboratorios Bioquimicos
Españoses S.A.*

United Kingdom:

*Advanced Protein
Products Ltd*

Main Contact:

Yvette Gouard

APP Ltd

Tel: +44 384 26 38 62

Fax: +44 384 48 03 51

Estimated Cost: 3.80 MECU

Time Scale:

*project completed
in September 1992*

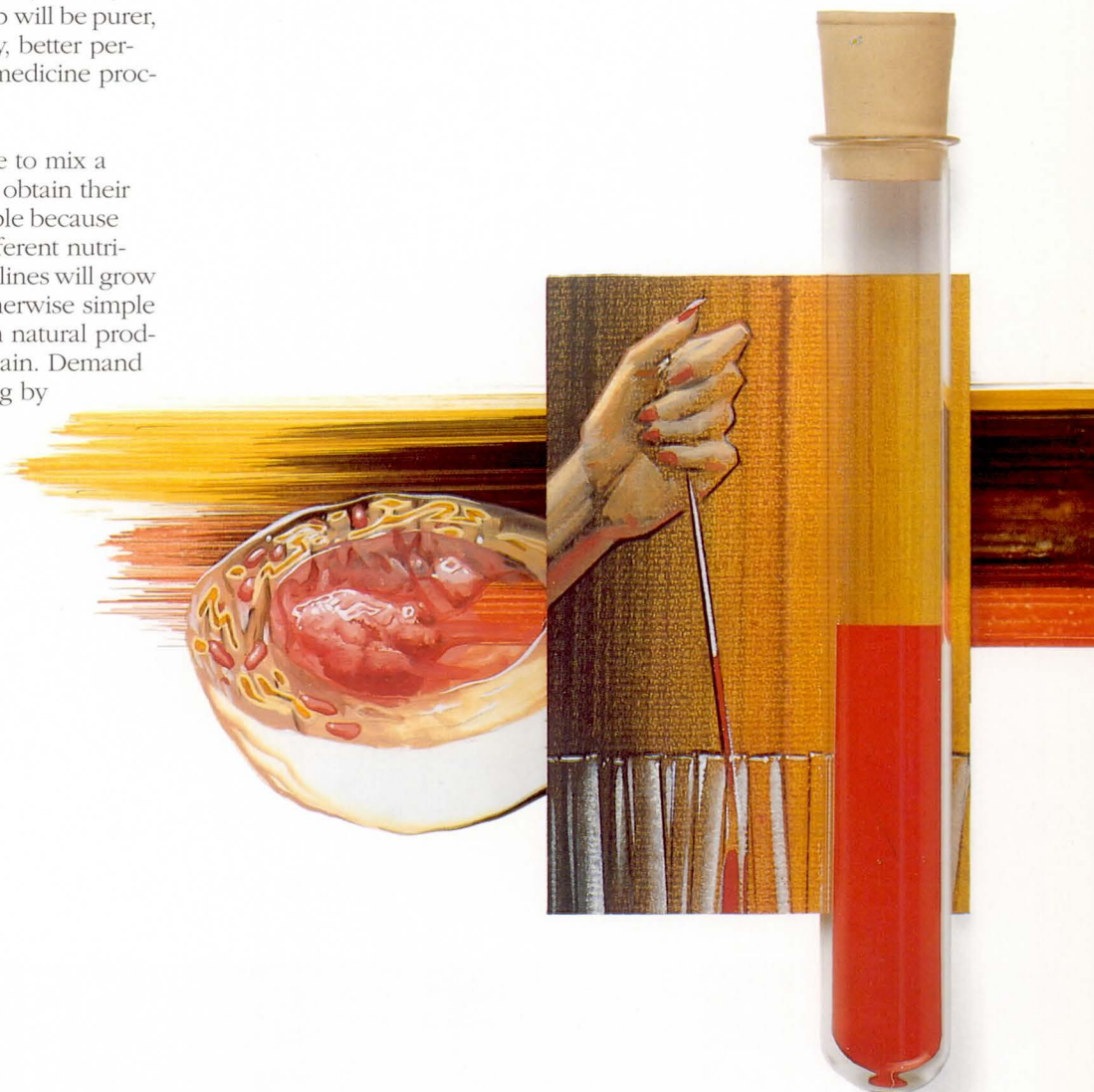

COST-EFFECTIVE PROTEIN SEPARATION

EU 384

*Medical and Biotechnology
Acronym: DYMECHROM*

*Title: Preparation and
studies of dyes and dye
sorbenis for purification
of biologicals*

*Announced at:
Vienna, 1989*

Participants:

Argentina:

Vilmax

Belgium:

*Smithkline Beecham
Biologicals S.A.*

France:

*IBF Biotechnics
S.A. (subsidiary of
SEPRACOR Inc)*

Greece:

*Agricultural University
of Athens*

Main Contact:

Dr. Egisto Boschetti

SEPRACOR S.A.

Tel: +33 1 46 85 92 98

Fax: +33 1 47 92 26 55

Estimated Cost: 1.33 MECU

Time Scale:

*project completed
in June 1993*

Many biotechnology products are currently purified using chromatography, where biological liquids are filtered through a column of tiny beads which have been coated with a substance that attracts and traps specific proteins. It is complex and expensive, however, so manufacturers need new agents to attract target molecules more specifically. Attaching antibodies to the beads are one alternative, but being biologically engineered is too expensive for industrial use.

A few years ago it was discovered that chemically synthesised dyes, used in a wide variety of industries, are another alternative. In fact, these cheap, highly available chemicals could theoretically replace the more expensive biochemicals currently used to separate and purify proteins such as human albumin (vital in the treatment of severe burns), interferon and Tissue Plasminogen Activator.

Until EUREKA project EU 384 - DYMECHROME, however, the 'immobilised dye' technique was confined to the laboratory, as it was feared that traces of the dyestuffs themselves might contaminate the protein. DYMECHROME is studying how dye traces leak from the beads, developing procedures for monitoring dye-traces in the purified protein and producing reliable data on their toxic effects. The end result will be a safe, cost-effective manufacturing processes for life-saving materials.

DYMECHROM brings together French company SEPRACOR, Smithkline Biologicals of Belgium, the Agricultural University of Athens and Argentinean dye manufacturer Vilmax, which had already been collaborating with SEPRACOR prior to the current project.

By the project's half-way point the partners had successfully selected the dyes, synthesised suitable derivatives, developed ways of fixing these onto the bead surface and identified antibodies for measuring dye traces. The second step showed that the technique was viable on an industrial scale and defined special applications, such as vaccine separation. Absence of dye toxicity was also formally demonstrated for at least two dyes.

There are three or four groups besides DYMECHROM making immobilised dyes. However, only SEPRACOR has a Drug Master File, awarded by the Food and Drug Administration of the United States. FDA approval will open the way for biotechnology manufacturers to use immobilised dyes on an industrial scale with complete confidence.

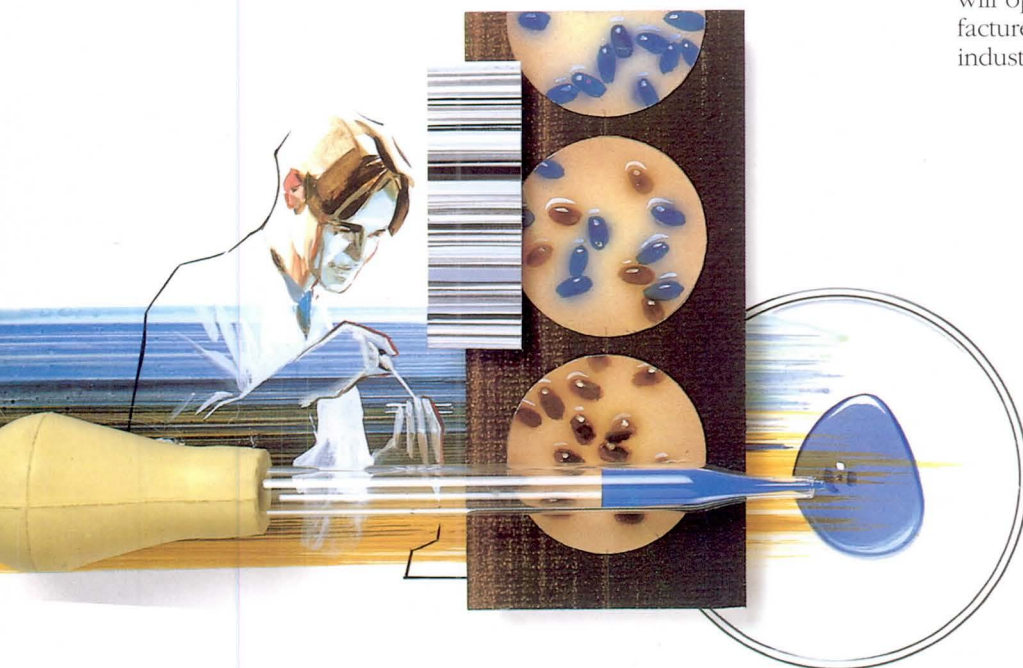

AN INTELLIGENT APPROACH TO SAVING ENERGY

Making homes, buildings and industrial processes more energy efficient benefits the environment, the home owner and company balance sheets, particularly with the introduction of carbon and other 'ecotaxes'. Technology developed under EUREKA EU 591 - ECS (Energy Communications Systems) will help owners of factories, schools, hospitals, homes and many other buildings to slash their fuel bill by providing sophisticated energy monitoring and control systems.

In 1993, three new products resulting from the ECS project reached the market:

3R Energy Management Software Package

3R - Right information to the Right person at the Right time - is a data processing and presentation programme which can operate in a number of modes. In manual mode, data on energy, resources and production are entered manually into the 3R database, allowing the analysis of the total energy cost per unit produced.

The most powerful version includes special energy recorders that can control or switch off motors or engines, locally or remotely, with complete two-way communication between the energy user and the utility. 3R is probably the most flexible system of its kind on the market today, and an English version was licensed to the USA, Canada and Mexico in August 1993.

The Perfectum Electronic Thermostat

A first on the market, the Perfectum Thermostat improves the 'energy intelligence' of existing electric heaters (panel, base-board, fan or radiant) which often only have a damaged bimetal thermostat.

The heater is simply powered through the Perfectum, which is an ordinary extension cord with a highly intelligent electronic thermostat in the middle and which is easy to install. 3,000 units of this brand new consumer product were sold in Sweden during August and September 1993 alone.

The Cresto Energy Management Board

The world's first educational Energy Management and Control System for users without computers. The highly affordable system allows building or industry owners to monitor and control energy use every week for three years. It is also an excellent educational tool for schools, where pupils can perform real energy management themselves, and for use as an information board in large buildings. Users can start with the Cresto Board and grow into the 3R system.

EU 591

Communication Technology
Acronym: ECS

Title: Energy Communication Systems

Announced at:
The Hague, 1991

Participants:

Austria:

Maschinda Handels
GmbH & Co. KG

Norway:

Cresto Technologies AS /
Siv. ing. Arne Palm A/S

Sweden:

MSS AB / Edström
Komponent AB

United Kingdom:

Measurement Systems Ltd

Main Contact:

Dr Ulf Rivenaes

Cresto Technologies A/S

Tel: +47 67 54 99 30

Fax: +47 67 54 99 25

Estimated Cost: 2 MECU

Time Scale: 3 Years

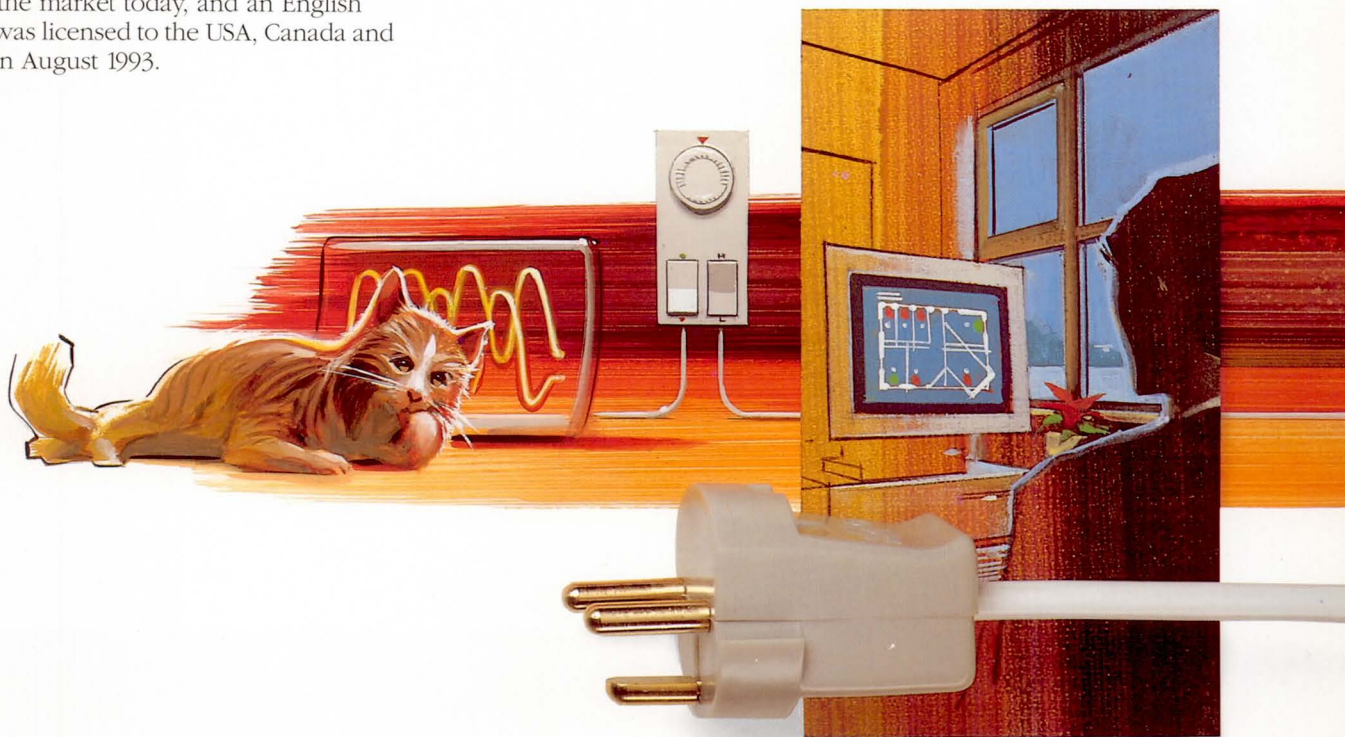

EFFICIENT, CLEAN ENERGY FOR THE WORLD MARKET

EU III

Energy Technology
Acronym: STABINE

Title: An advanced power generation system compounding a diesel cycle to that of an industrial gas turbine

Announced at: London, 1986

Participants:

Belgium:

Cockerill Mechanical Industries S.A.

France:

Stabine S.A. / Commissariat de l'Energie Atomique / Hoerbiger France / Sulzer France / Total France

Hungary:

Olaszterv

Russia:

Trud / Consta

Main Contact:

Stabine S.A.

Mr. Henry Benaroya

Tel. +33 1 47 47 60 30

Fax: +33 1 46 24 12 99

Estimated Cost: 16 MECU

Time Scale:

Expected to be completed in June 1995

French engineering SME Stabine S.A., along with its partners in EU III - STABINE, is moving ahead with plans to build its first prototype power stations in Canada and Russia. All will incorporate gas turbines designed and built in Russia, and combine low investment cost with high fuel efficiency and low emission levels.

In any gas-fired power station, fuel is mixed with compressed air in a combustion chamber. The resulting energy is captured by gas turbines, but around two-thirds of it is usually reused by the air compressor, leaving one-third for electricity production.

By using a separate, specially designed diesel engine to compress the air, the partners have both improved efficiency and reduced the required capital investment, lowering the cost of a kilowatt-hour by about 12%.

In addition, innovative technology patented by their Hungarian partner will efficiently and cheaply cut NOx pollution.

The actual turbines used will be built by Trud, Russia's main producer of aero-turbines. They are working closely with Consta, a joint venture between Stabine and Conversia, a Russian company specialising in converting military industries to civilian markets.

The project's next step is to build a full-scale prototype station. One of the most promising markets is Canada, where investment in small power plants is encouraged.

Construction of the proposed 20 MW prototype, costing around 13 MECU in total, will probably begin in Quebec in the mid-1990s. Post-prototype plants will of course cost less, while both diesel and 'combined cycle' gas-fired plants, with the same capacity and efficiency, already cost 40-100% more.

In Russia, negotiations are underway with both the municipality of St. Petersburg and Gasprompt, a Russian producer and distributor of natural gas. Gasprompt is interested in using 10 or 20MW plants to power their gas pumping stations, which are needed for every 100 km of pipeline. It is an enormous market - Gasprompt bought 10,000 MW of capacity for this purpose in the 1970s.

Success will help Russia tap its natural gas reserves efficiently and sustain and convert its industrial base, as around 80% of each plant will be built in Russia. A similar result is hoped for in Hungary, where that country's acceptance into the EUREKA Initiative released government support for a full feasibility study. In the future, all of Central and Eastern Europe, where environmental and power supply problems are inextricably linked, could benefit from the STABINE solution.

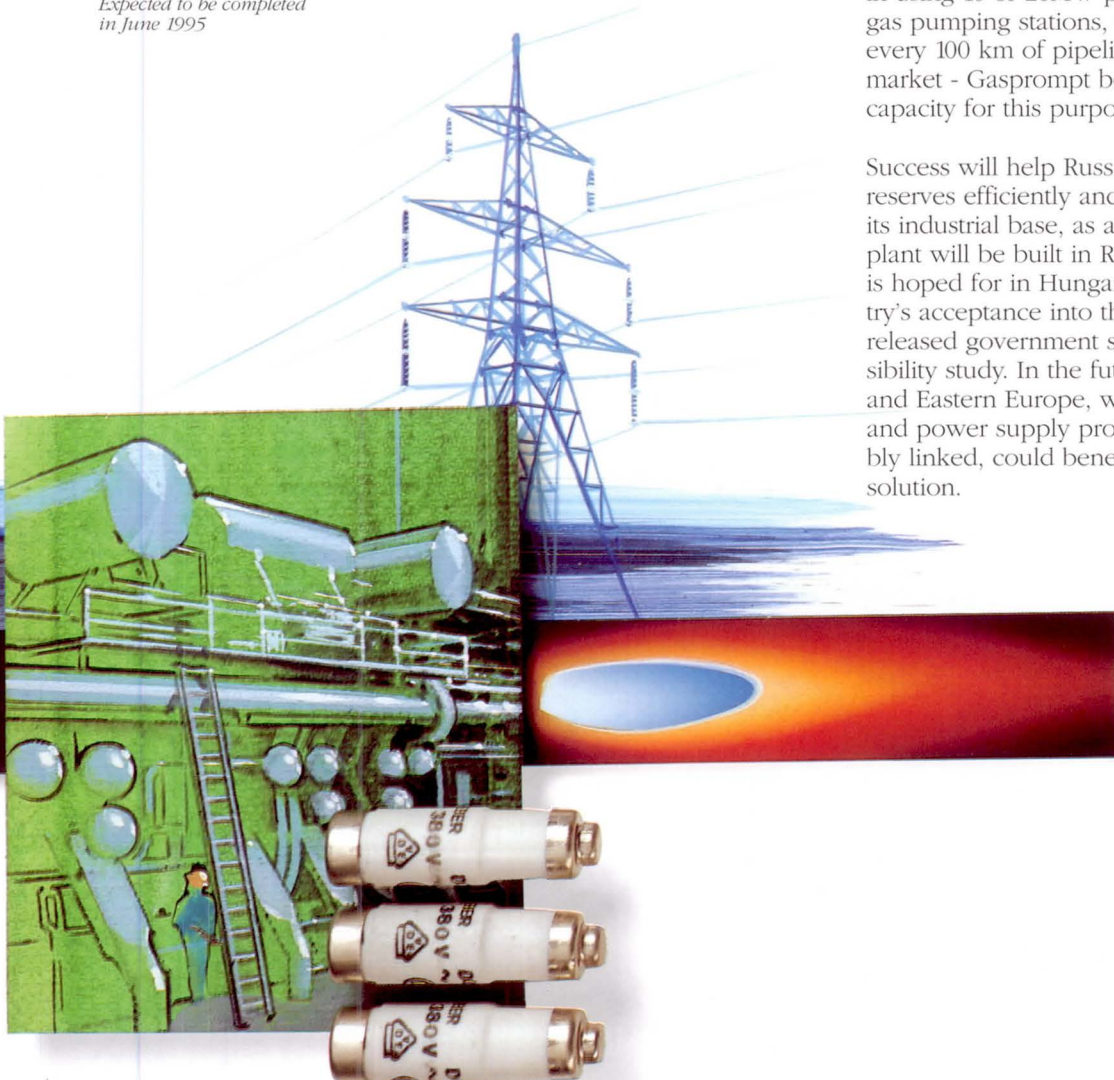

TOWARDS THE RECYCLABLE CAR

Currently the automobile industry's waste plastics are disposed of in landfill sites. EUREKA project EU 506 - EUROENVIRON-RECAP, initiated by Italian petrochemical concern Enichem, car manufacturers Fiat and PSA and international chemical company ICI, aims to reduce this environmental burden by recovering and recycling more of the waste plastic produced during vehicle manufacture and scrapping. The project will also help redesign cars to make recovering and re-using these wastes easier.

The car manufacturing partners produced a database allowing the identification and classification of scrap plastic materials. This database accounts for current manufacturing criteria and plastic utilisation throughout the automobile industry, and will include information on plastic types, quantities and production rates. The database's open-ended structure will allow it to be extended to other car manufacturers in different countries, eventually leading to a Europe-wide waste management network.

The car manufacturers also set up a more efficient organisation for collecting and disposing of assembly line wastes, and plan to develop pilot plants to study the recycling of polyurethane and thermoset-based residues.

The chemical companies, meanwhile, studied the recycling of mixed thermoplastics, which are currently difficult to re-use. The challenge is to find chemical and thermal techniques to breakdown mixed plastics into their components, making recycling easier, and to develop physical treatments to upgrade their quality.

These recycled plastics could be much more extensively applied than they are now, particularly in car interiors where they are not visible.

The chemical companies also researched new plastic materials, with a special emphasis on ease of recovery and re-use. This will help car manufacturers develop new design criteria for more easily recyclable components, and increase their use of recovered plastics in their processes.

The aim is to find and demonstrate cost-effective solutions, as it is extremely difficult to introduce major changes in large scale car manufacturing processes. RECAP's answers will also find applications in other fields which share similar problems, such as the tyre and white appliance industries.

EU 506

Environment Technology
Acronym:
EUROENVIRON-RECAP

Title: Recovery and Reuse of Plastic Materials Derived from Automobile Production and Scrapping.

Announced at: Rome, 1990

Participants:

Belgium:

ICI Europa Limited

France:

PSA

Italy:

Enichem S.p.A
(Donegani Research Institute, Monteco, Montedipe) / Fiat Auto

United Kingdom: ICI Chemicals and Polymers Limited

Main Contact:

Dr. P Schwartz

Instituto G Donegani

Tel: +39 321 44 72 58

Fax: +39 321 44 76 79

Estimated Cost: 20.0 MECU

Time Scale: 5 years



DOUBLE TANKS FOR STRENGTH AND SAFETY

EU 739

Environment Technology
Acronym:
EUROENVIRON-ECO-TANK

*Title: Environmentally Safe,
Double-Walled, Fibre-
Reinforced Plastic (FRP)
Storage Tanks with Leak
Detection*

*Announced at:
Tampere, 1992*

Participants:

*Austria:
Kunststoff Verbund
Systeme GmbH (KVS)*

*Netherlands:
Parabeam Industrie /
Plasticon Heerenveen*

*Main Contact:
Ing. Kees Swinkels
Parabeam Industrie BV
Tel: +31 4920 701 95
Fax: +31 4920 707 33
Estimated Cost: 0.54 MECU
Time Scale: 2 years*

All over the world, underground storage tanks are leaking petrol, solvents and other chemicals into the soil. To stop this situation getting worse, a 1994 EC standard now forces companies storing hazardous liquids underground to use double-walled tanks fitted with leak detection systems.

Although effective, double-walled tanks are rarely used as they are 25-40% more expensive, being in fact one tank inside another. With thousands needing replacement, users are worried about costs.

However Dutch company Parabeam, the lead partner in EUREKA project EU 739 - ECO-TANK, has developed a fabric made of special glass-reinforced plastic (GRP) that will result in economic, double-walled tanks with a lifetime 15 years longer than the steel alternative.

Parabeam employs around 15 people, and saw its market - making velvet curtains - declining. Looking for new uses for its textile machinery, it landed upon 'three-dimensional fabrics' made from glass fibre.

While velvet is made by weaving two layers of cotton fabric together and then slicing them apart, forming velvet's unique 'pile', Parabeam leaves the glass fibre pile uncut, so that the two layers of fabric remain connected. When the fabric is impregnated with resin, the stiff pile holds the two layers apart. The result is a strong, rigid sandwich of two sheets of GRP, separated by a gap of around five millimetres. The integrated structure is hollow, so it allows the tank manufacturer to make a double-walled tank which is still one structure, and is stronger than a single layer.

Because the new fabric can be handled just like conventional glass cloth, tank manufacturers should find it easy to work with. Parabeam has teamed up with tank manufacturers, KVS from Austria, and Plasticon from the Netherlands in the project. KVS has used the new fabric to build fifteen tanks so far, all for use above ground. Plasticon has made half a dozen tanks, one of which will be used underground.

More than a dozen other manufacturers are now waiting for a report from German certification body TÜV on the chemical resistance of the new structure. Once it has the TÜV's seal of approval, Parabeam is confident that the fabric will be important in helping the oil and chemical companies meet their environmental responsibilities.

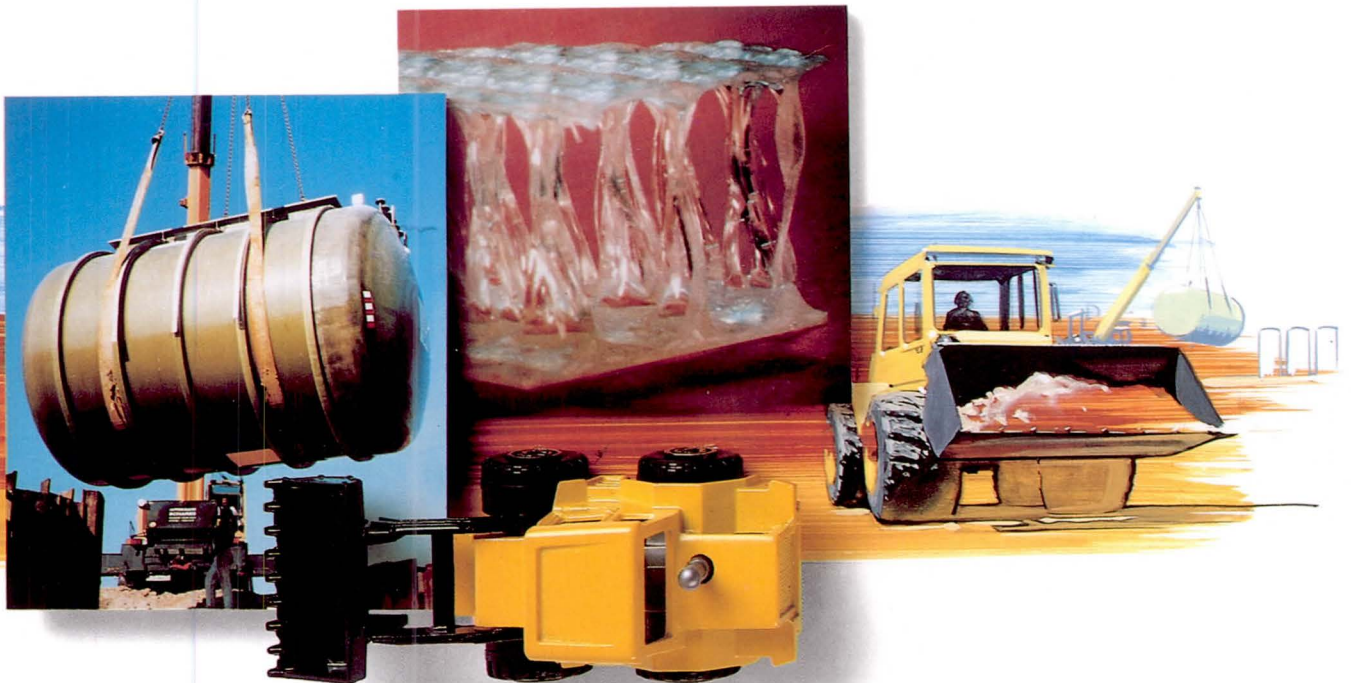

PARALLEL PROCESSING: EXTENDING OIL AND GAS RESERVES

Prospecting for oil and gas is usually undertaken by means of a seismic survey, where sonic shocks are emitted and their echoes off geological structures analysed. The technique produces vast amounts of data, which usually takes a month to process before useful pockets of fuel can be discovered. In addition, main-frame computers are used to run day-long reservoir simulation programs to calculate the best strategy for exploiting the fuel deposit.

Processing seismic data is the single most intensive civilian computer application. In the mid-1980s, 20% of the world's super-computing power was used by the petroleum industry this way. PARSIM, EUREKA project EU 638, aims to reduce the time taken by data analysis from one month to one day, and make reservoir simulations possible in real-time on desktop computers.

PARSIM is a joint Danish-British venture, involving simultaneous developments in both software and hardware. Hardware developments focus on a specialised high-performance parallel computer system and a new computer disc system, which may have applications outside the petroleum industry.

Software developments will concentrate on processing seismic data and modelling reservoirs. The reservoir simulator calculates various parameters within the reservoir, such as the pressure of oil, gas and water.

Additionally, a program called COSI (Compositional Simulation), modified for use on a parallel computer, takes into account the various properties of different hydro-carbon components within the reservoir, an improvement on traditional systems which treat the entire oil deposit as homogeneous.

The COSI software running on the PARSIM parallel computer will therefore give a faster and more accurate representation of oil and gas deposits. The initial market in the North Sea is estimated at 100 machines for reservoir simulation and 100 machines for seismic survey analysis.

The project will improve techniques in exploiting oil and gas fields. Only 10-20% of oil and gas reserves are extracted at present, so enhancing this figure by an extra few percent will make other smaller, more marginal fields become viable, stimulating the industry and securing Europe's supply of oil and gas for a longer period, at a lower price.

EU 638

Information Technology
Acronym: PARSIM

Title: Cost-effective, interactive parallel simulation with application in the petroleum industry

Announced at:
Tampere, 1992

Participants:
Denmark:

Cowiconsult A/S/
Math-Tech APS/
Oedegaard &
Danneskiold-Samsøe APS

United Kingdom:

Geomatrix/
National Transputer
Support Centre/
North West Regional
Transputer Support
Centre / Parsys Ltd

Main Contact:

Mr Jesper Larsen

MATH-TECH APS

Tel: +45 31 63 69 88

Fax: +45 31 68 31 95

Estimated Cost: 6.8 MECU

Time Scale: 3 years



POOLING EXPERTISE IN HIGH POWERED LASERS

EU 194

Lasers Technology
Acronym:
EUROLASER-CO₂ HP

Title: *Industrial Application
Evaluation of High Power
Lasers*

Announced at:
Madrid 1987

Participants:
Participation from
organisations in:

*Austria
Denmark
France
Germany
Greece
Italy
Norway
Portugal
Spain
Sweden*

United Kingdom

Main Contact:
*Dr. A. Quenzer
Club Laser de Puissance
Tel: +33-1-42 31 98 80
Fax +33-1-42 31 99 92*

*Estimated Cost: 46.2 MECU
Time Scale:
To be completed
in July 1994*

High power CO₂ lasers offer enormous potential in improving a wide range of industrial processes. Finding or acquiring the necessary expertise and finance to exploit this technology, however, is beyond the means of many companies.

To help make these lasers more accessible to European industry, representatives from a number of European companies involved in making or using lasers, along with Europe's main laser application labs, formed EUREKA project EU 194 - EUROLASER - CO₂ HP, under the EUROLASER umbrella project. The project will run until July 1994.

The partners aimed to both help European laser manufacturers compete on the world market and help European industry make the most of high power laser technology. No one company could have tackled this project on its own, but by working together the partners shared the risk, and each participant concentrated on the laser processes and designed the type of hardware they knew best.

From the beginning, the participants worked in five subgroups:

- laser optics, including the beam characterisation of a high powered CO₂ laser;
- experiments designed to help standardise applications;
- mathematical modelling;
- studies of new applications such as welding, cutting and, particularly, very high power surface treatment;
- devising of safety and quality control standards and the development of instruments to analyse the laser beam.

In a second phase, several laser processes were worked out in common workshops, where the partners successfully shared their knowledge and experiences. There were several new developments, including improved surface treatment techniques which, by reducing corrosion and allowing the production of smaller, more robust components, can double the lifetime of car engines and other products. The partners' work on safety issues now means that high powered lasers can be used where precision and accuracy are crucial, such as inside nuclear power plants. A database on CO₂ laser application has been produced. Lastly, some partners developed potentially commercial products, such as beam guiding and analyser systems, focus control modules, safety systems and more.



NEW RUBBER TECHNOLOGY BOUNCES EUROPE AHEAD

Natural rubber has been known and valued for its elastic properties for centuries. Silicone rubber is also highly elastic, but it also has several advantages over the natural product. It is stable over a wide range of temperatures (-50° C to +250° C), is resistant to acids, alkalis, oils and other corrosives, and does not age and perish as quickly as natural or other synthetic rubbers.

Silicone rubber products are especially attractive for medical and surgical applications because they are non-toxic and do not stimulate a reaction from the body's immune system, making their softness and suppleness suitable for surgical implants, catheters and other invasive medical devices. In addition, producing liquid silicone rubber (LSR) is environmentally benign, requiring simple, readily available starting materials such as sand, methanol, hydrochloric acid and water. Likewise, unwanted LSR products can be completely destroyed by incineration, creating no harmful emissions or residues.

Interest in silicone rubber has grown in the past decade with the development of LSR, which promises to make possible many new applications. EUREKA project EU 352 - LSR SYSTEM, is at the vanguard of this technology, developing new formulations of liquid silicone rubber suitable for new applications and working on new injection moulding technologies to help automate LSR product manufacturing processes.

The partners include UBALIT, an Italian producer of thermoplastics and silicone rubber, and Wacker-Chemie, the world's largest producer of silicone rubber. They are also one of the leading suppliers of LSR, and will be responsible for the production of the basic components of LSR and marketing the improved materials world-wide.

The range of applications is simply vast. The first was a new urinary catheter, to be marketed in the US from 1994. Future applications include cable seals and O-rings for the automotive industry, baby nappies, connectors for solar-powered calculators, tele-phones, and sanitary fittings. Marketing agreements have already been reached with major international companies in Italy, Germany, US and Japan. The estimated future market for these products is 150 MECU in Europe alone.

EU 352

New Materials
Acronym: LSR SYSTEM

Title: Technologies for industrial production of moulded parts made from synthetic rubber from organic silicon compounds.

Announced at:
Vienna, 1989

Participants:
Germany:
Wacker-Chemie GmbH

Italy:
UBALIT -
Industria Componenti
Termoplastici SPA /
CNR Istituto di Ricerche
su Tecnologie dei Polimeri
e Reologia

Main Contact:
Ricardo Baldini
UBALIT
Tel +39 51 65 44 294
Fax +39 51 65 45 260
Estimated Cost: 3.5 MECU
Time Scale:
project completed
in November 1992

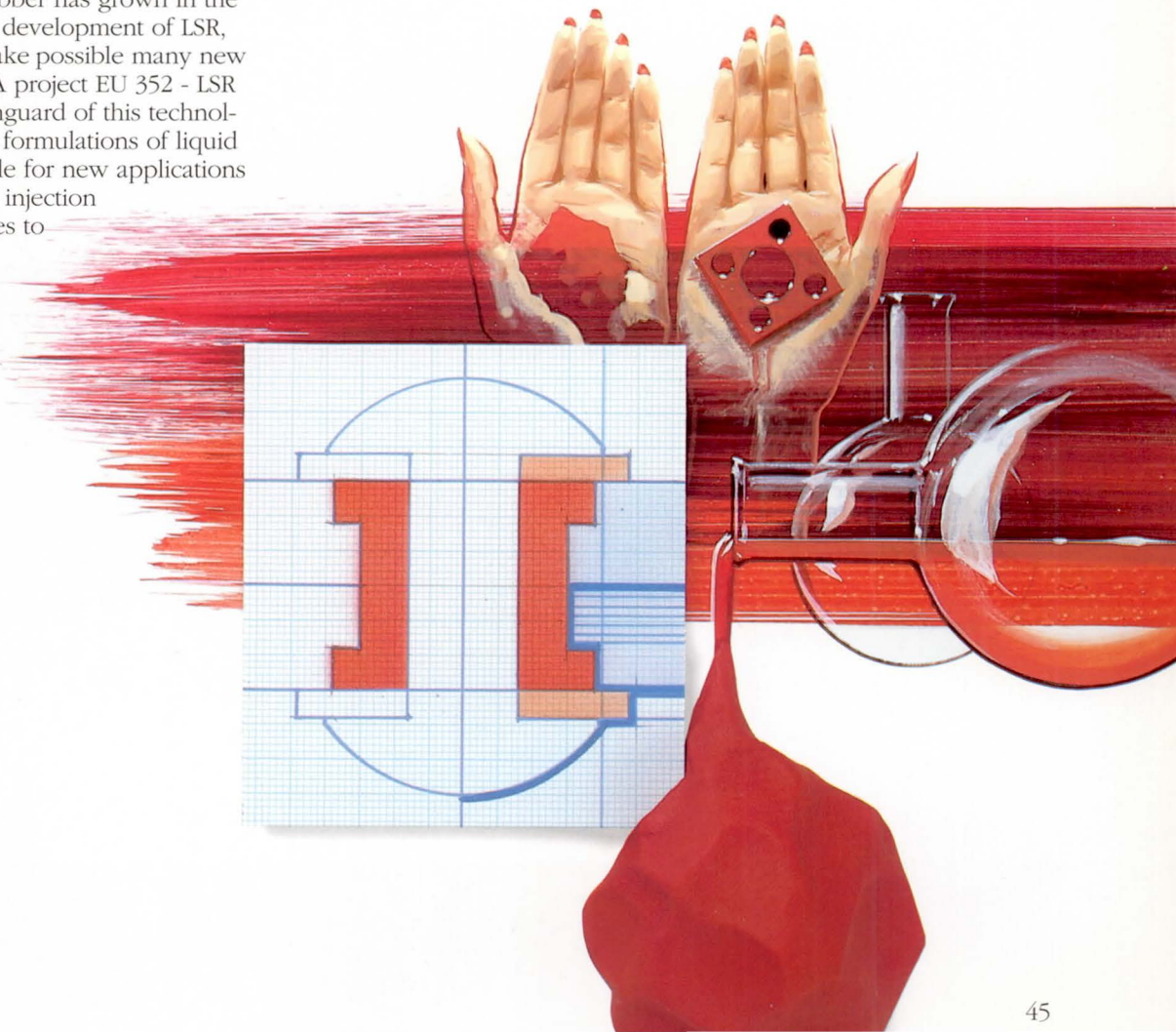

ADVANCED AND INTEGRATED ROBOT SENSOR SYSTEMS

EU 276

*Robotics and Production
Automation
Acronym: FAMOS-SEMOS*

Title: Design, implementation and integration of sensor aided assembly systems with industrial robots.

*Announced at:
Copenhagen, 1988*

Participants:

Austria:

*Österreichisches
Forschungszentrum
Seibersdorf*

Germany:

*Fraunhofer-Institut für
Produktionsanlagen und
Konstruktionstechnik /
Isra Systemtechnik GMBH
/ Kuka Schweißanlagen
und Roboter GMBH /
Kontron Bildanalyse
GmbH*

Greece:

*NTUA National Technical
University of Athens /
Zenon S.A. Industrial
Automation /
Elefsis Shipyards SA*

The Netherlands:

*Delft Instruments BV
(Oldelft)*

Turkey:

*ÖLSAN - Ölçü Aletleri
Sanayi AS / ITÜ Technical
University Istanbul*

Main Contact:

*Prof. Dr. Günter Seliger
IPK - Fraunhofer-Institut
für Produktionsanlagen
und
Konstruktionstechnik
Tel: +49-30-31 42 20 14
Fax: +49-30- 391 10 37*

Estimated Costs: 9.74 MECU

Time Scale:

Completed in 1992

Improving industrial competitiveness requires greater automation on the assembly line. As robots become more sophisticated, so too must the sensors they need to see and manipulate. The FAMOS-SEMOS project (EU 276) aimed to satisfy that market by designing, implementing and integrating sensor-aided assembly systems with industrial robots.

Sensor-guided assembly is actually quite rare, with sensor systems usually made for special applications like welding. The SEMOS project, however, worked on more flexible sensor systems with a greater variety of applications, developing and integrating the missing elements for the sensor-guided assembly processes of the future.

SEMOS aimed to first improve the 'sensitivity' of the robots. New developments included geometry sensors, vision systems and force-torque sensors. The integration and interfacing of different intelligent components into one system formed the next crucial aspect. SEMOS also tackled the poor software flexibility of sensor systems and the inadequate design in relation to shop floor condition problems.

The project, which finished in 1992, organised into networks both the manufacturers of robots, sensors and integration equipment and the users of flexible automated assembly systems. This allowed component and system suppliers to discover end-user needs and test their systems in realistic shopfloor environments. Six working groups were set up, with 'demonstrator partners' integrating sensor systems and robots to realise prototype industrial applications with user partners.

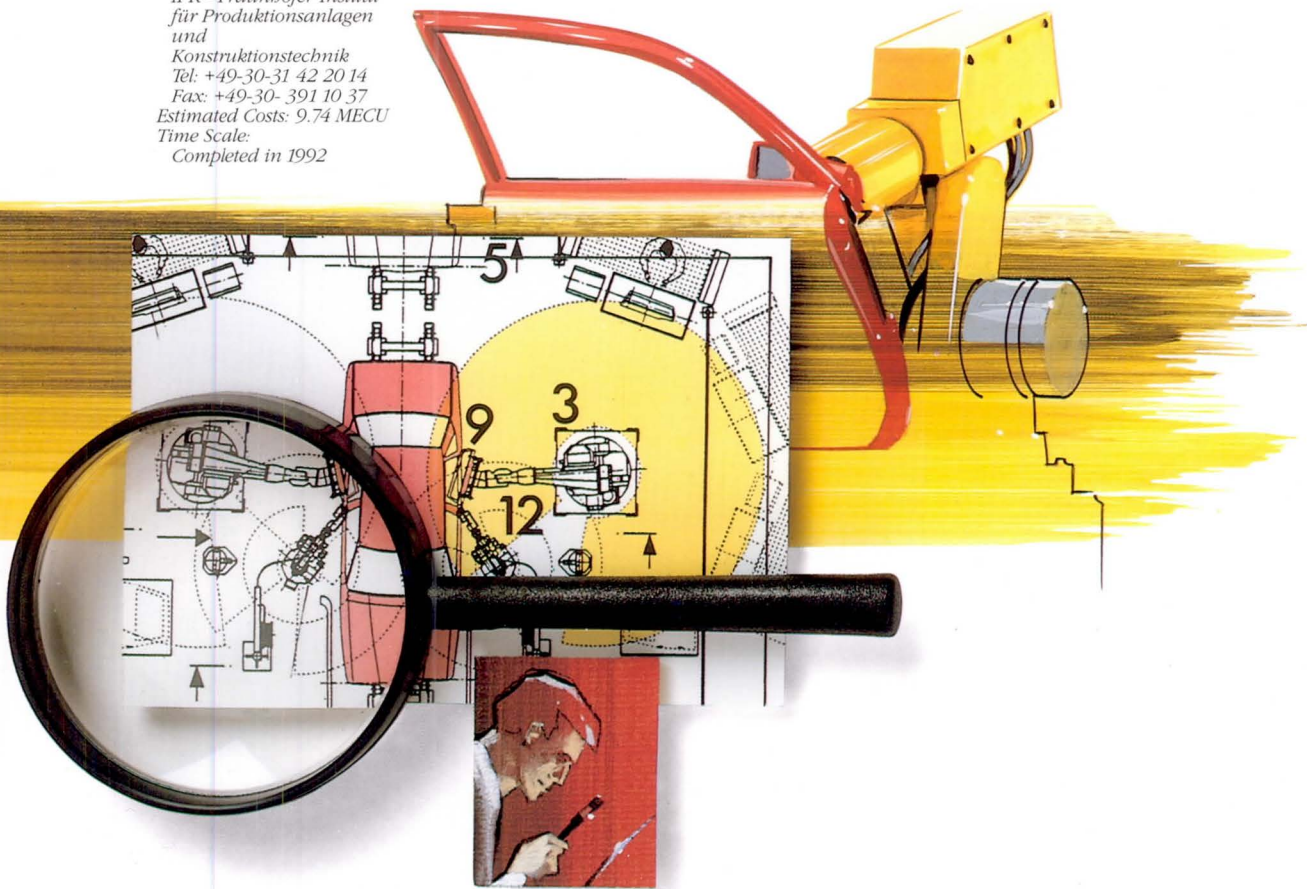

BRICKLAYING WITH SPEED AND SAFETY

Brick is an attractive, versatile material that forms an essential part of most traditional European architecture. But because each brick has to be placed individually, building in brick can be slow and expensive compared to materials such as prefabricated concrete sections.

It is also heavy work, and many bricklayers suffer from chronic back pain and other ailments. In fact bricklaying is falling behind modern occupational health standards, and it is becoming increasingly difficult to find skilled workers.

The BRICKBUILD project (EU 542) aims to solve both problems by automating parts of the bricklaying process. The project will not replace the bricklayer with a robot. Instead, mechanised platforms and other equipment will make working conditions much more comfortable and bricklaying less labour-intensive. The result should be higher productivity and quality, with fewer injuries.

The motorised platform moves on two tracks running the length of the building, supported by standard scaffolding. It carries a supply of bricks and mortar, and can also be enclosed by a cabin equipped with heating, lighting and impact protection. A single assistant is needed to supply the bricklayer with bricks and mortar using a power hoist, located at one end of the track.

The bricklayer starts at one end of the wall and lays bricks from knee to shoulder level, moving the platform along as necessary. This is significantly more comfortable than before, when bricklayers had to bend to ankle level and stretch to head height. The hoist then lifts the track sections up to the next level, one piece at a time. When the entire track is one metre higher, the platform is lifted onto it and the bricklayer begins on the next level of bricks.

Lohja, the main industrial partner, has built and tested a prototype system in collaboration with their partner VTT, the Technical Research Centre of Finland. In 1991 the partners successfully used it to build 440 square metres of wall for a real apartment building, under normal site conditions.

Productivity was nearly as good as with conventional bricklaying, and will be considerably improved with small changes in working methods. These are being developed, as is a hand-held 'gun' to dispense mortar and the ability to move the deck around corners of the building under construction.

EU 542

*Robotics and Production
Automation
Acronym: BRICKBUILD*

*Title: Mechanisation of
Bricklaying Technology
on the Building Site
Announced at: Rome, 1990*

*Participants:
Finland:
Lohja Oy AB /
Technical Research
Centre (VTT)*

*Germany:
Matbis Technik GmbH
(M-Tec)*

*Sweden:
Stråbruken AB*

*Main Contact:
Mr. Hannu Koski
VTT Building Production
Laboratory
Tel: +358 31 16 31 11
Fax: +358 31 16 34 45
Estimated Cost: 2.1 MECU
Time Scale: 6 years*



TUNNEL SAFETY FOR A GROWING EUROPE

EU 499

Transport
Acronym: FIRETUN

Title: Fire protection
in Tunnels for Traffic on
Rail and Road
Announced at: Rome, 1990
Participants:

Participation from
organisations in:
Austria
Germany
Finland
France
Italy
Norway
Sweden
Switzerland
United Kingdom

Main Contact:
Mr. Hüller
Studiengesellschaft
Stablanwendung EV
Tel: +49 211 82 93 81
Fax: +49 211 82 93 44
Estimated Cost: 4.6 MECU
Time Scale: 4.5 years

Europe has a large number of underground tunnels, both for rail and road, and the network is growing - with internal barriers falling and trains becoming faster, new projects range from the Channel Tunnel to urban subway systems.

Therefore the lack of information about the one of the most devastating situations that can occur underground - fire - is surprising. Very little is known concerning how and why fires start, nor the best methods for rescuing people, extinguishing the blaze and repairing the damage. This serious gap in our knowledge is something that EUREKA project EU 499 - FIRETUN, aims to fill.

FIRETUN was begun in Germany but the work has been split between Germany, Finland and Norway. The Technical Research Centre of Finland has collaborated with STUVA and the University of Braunschweig on both mathematical simulations and scale model studies of tunnel fires, which were used to define full scale tests.

These tests took place in a disused mine-tunnel in Norway, with the help of the Norwegian Road Research Laboratory and Olfo, a fabrication company.

The tests provided data on how fire, temperature, smoke and toxic gases spread in a tunnel, how ventilation systems can help disperse unwanted gases, how best to operate rescue missions and the reaction of various types of tunnel linings to the fire.

The studies are still underway, but solutions are beginning to form. It appears that road tunnels should have at least one extra lane for emergency vehicles, as well as a sophisticated monitoring network and water supply system. Longer tunnels should also be equipped with an adequate ventilation system. But one of the most important factors may be the construction and furniture material used in cars and trains, as burning plastics can produce dense clouds of toxic smoke which can make rescue situations much more desperate.

The group will publish the results of their work when the project finishes in the mid 1990's. They will be made available to all authorities and industries involved in the field, ensuring a safer European transport through tunnels for the years ahead.

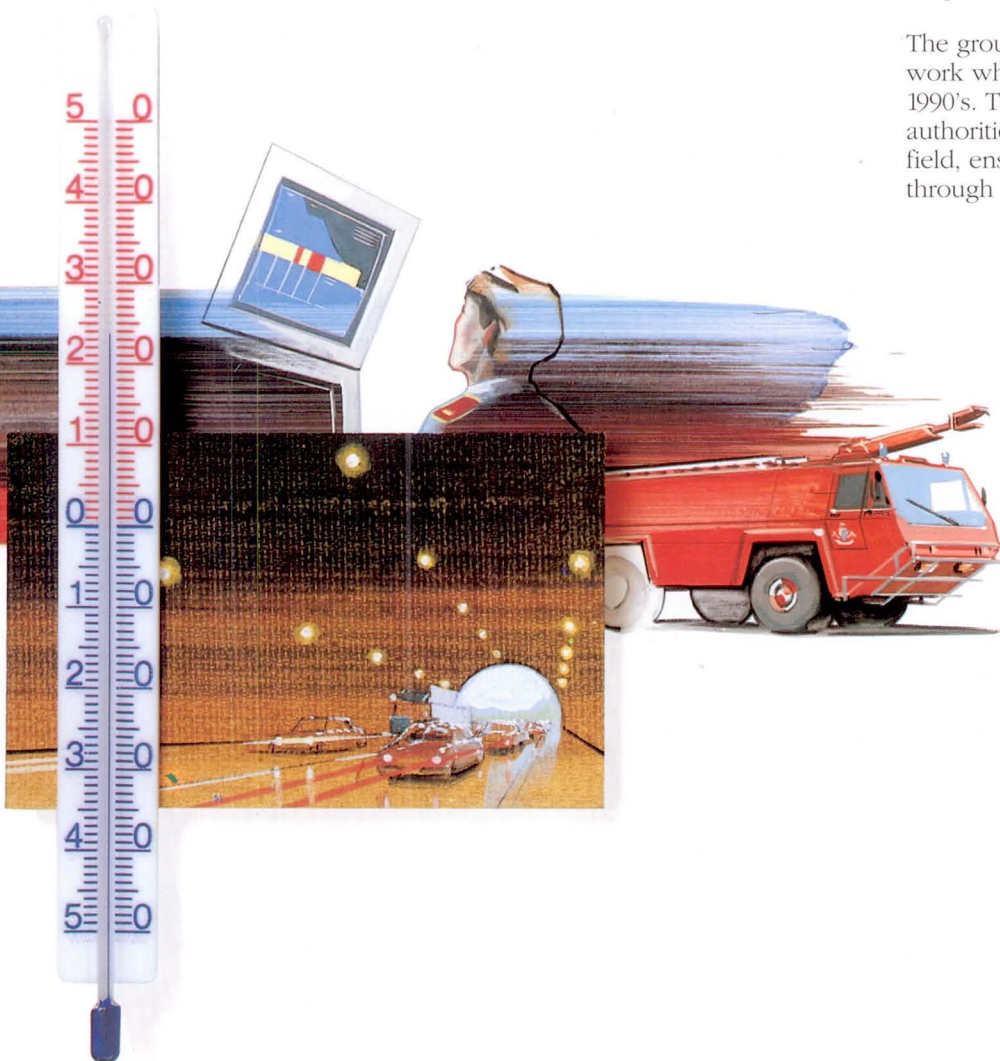

BIBLIOGRAPHY

For the interested reader, further material on EUREKA is available upon request from the respective National Project Coordinators or the EUREKA Secretariat (see addresses on Pages 50 and 51).

Material available in English, French, German, Italian and Spanish includes:

- Annual Progress Reports
- EUREKA News (published quarterly)
- EUREKA Brochure (containing a short general description of the Initiative).
- Vademecum (containing, inter alia, a guide to EUREKA project participation and the Hannover Declaration of Principles)

Other publications are only available in certain languages:

Technology Folders (in English) on

- Medical and Biotechnology
- Communication Technology
- Energy Technology
- Environment Technology
- Information Technology
- Robotics and Production Automation
- Transport Technology
- Laser Technology (to appear early in 1994)
- Materials Technology (to appear early in 1994)

Checklist for the Negotiation and Drafting of an International R&D Cooperation Agreement in the Framework of a EUREKA Project (English and French)

Guidelines for the Protection of Technological Information (English and French)

Guide to Standardization for Companies Involved in EUREKA Projects (English and French)

Cross Border Innovation Booklet (English)

Le contrat modulaire d'assurance des projets EUREKA (French)

Assessment Report/Dekker Report (English)

Evaluation of EUREKA's Industrial and Economic Effects (English; summaries also in French, German, Spanish, Italian)

Jubilee Book (English)

SME guide (English)

Supportive Measures Booklet (English)

Open the door to EUREKA (English)

EUREKA and Central and Eastern Europe (English)

In addition, several brochures and newsletters are published at national level.



The EUREKA Database

The EUREKA database, which is run by the EUREKA Secretariat, contains a wealth of information on announced or proposed projects including the R&D fields covered, technological goals, implementation schedules, budgets, participants and contact addresses. It is a tool for potential industrial and scientific partners.

The information contained in the EUREKA database can be obtained from the National Project Coordinators or the EUREKA Secretariat in Brussels (see addresses on Pages 50 + 51) or accessed directly via the ECHO (European Commission Host Organisation) computer in Luxembourg through a standard terminal linked to ECHO via the X25 data network (international address 0270 448 112 or A9270 448 112 for users from the United Kingdom) or via the international telephone network (+ 352 43 64 28 if a 300 bits modem is used or +352 42 03 47 if a 1200 bits modem is used; password "EUREKA" in both cases) or accessed via the TELETEL network in France using a Minitel terminal (code 3617-EUROBASE) or accessed via the French Transpac network (Code 3617) or via an international line (+33 36 43 15 15; select EUROBASE service).



NPC ADDRESSES



AUSTRIA
Mr. Herwig Renner
BIT (Bureau for International
Research and Technology
Cooperation)
Wiedner Hauptstr. 76
A - 1042 WIEN
Tel +43 1 581 16 16 Ext 113
Fax +43 1 581 16 16 16

BELGIUM
Mr. Guillaume
Dedeurwaerder
Science Policy Office
Rue de la Science 8
B - 1040 BRUSSELS
Tel +32 2 238 35 58
Fax + 32 2 230 59 12

DENMARK
Civ. Ing. Poul Knudsen
Danish Agency for Develop-
ment of Trade and Industry
Tagensvej 137
DK-2200 COPENHAGEN N
Tel +45 35 86 83 18
Fax +45 35 86 86 87

EUROPEAN UNION
Mr. Nicholas Newman
DG XII - B-1
(Office BEL 68-5/43)
200 Rue de la Loi
B - 1049 BRUSSELS
Tel +32 2 295 59 76
Fax +32 2 296 42 89

Dr. Michel Progent
DG XIII BU 24 3/88
200 Rue de la Loi
B - 1049 BRUSSELS
Tel +32 2 296 88 64
Fax +32 2 296 83 59 /
Fax - 32 2 296 88 67

FINLAND

Dr. Martti af Heurlin
TEKES
Technology Development
Centre
P.O. BOX 69
Malminkatu 34
FIN - 00101 HELSINKI
Tel +358 0 69 36 7800
Fax +358 0 69 36 7795

FRANCE

Mr. Serge Gregory
Secrétariat Français
EUREKA
43 Rue de Caumartin
F - 75436 PARIS CEDEX 9
Tel +33 1 40 17 85 86
Fax +33 1 47 42 32 40

GERMANY

Mr. Erich Niermann
Federal Ministry for Research
and Technology
(BMFT, Referat 222)
D - 53170 BONN
Tel +49 228 59 31 64
Fax +49 228 59 36 04

GREECE

Prof. Dionyssios Monopolis
Ministry of Ind.,
Energy & Technology
Gen. Secretariat for Research
& Technology
14-18 Messogion Ave.
(Abelokipi)
P.O. BOX 14631
GR - 115 10 ATHENS
Tel +30 1 69 11 122 ext 333
Fax +30 1 77 13 810
Fax +30 1 77 14 153
Fax +30 1 72 12 729*
* (c/o Mr. KAKOUIROS)

HUNGARY

Mr. Pál Koncz
EUREKA Secretariat
National Committee for
Technological Development
(OMFB)
Szervita tér 8
H - 1052 BUDAPEST
Tel +36 1 11 75 782 /
Tel +36 1 11 75 900
Fax +36 1 26 60 800

ITALY

Ministero dell'Università e
della Ricerca Scientifica e
Tecnologica
Lungotevere Thaon
de Revel 76
I - 00196 ROMA
Tel +39 6 32 21 581
Tel +39 6 32 32 634
Fax +39 6 32 34 329
Fax +39 6 32 21 584

IRELAND

Dr. Ronan Breslin
FORBAIRT
The Irish Science &
Technology Agency
Ballymun Road
Glasnevin
IRL - DUBLIN 9
Tel +353 837 01 01
Fax +353 837 01 78

ICELAND

Dr. Vilhjalmur Ludviksson
The National Research
Council
Laugavegur 13
IS - 101 REYKJAVIK
Tel +354 1 62 13 20
Fax +354 1 298 14

LUXEMBOURG

Mr. Marco Walentiny
Ministère de l' Economie
19-21 Boulevard Royal
L - 2914 LUXEMBOURG
Tel +352 478 41 62
Fax +352 418 14

NETHERLANDS

Mr. L.J.A.M. van den Bergen
Netherlands EUREKA
Secretariat
c/o SENTER
Grote Marktstraat, 43,
P.O. BOX 30732
NL - 2500 GS DEN HAAG
Tel +31 70 36 10 311
Fax +31 70 36 10 355

NORWAY

Dr. Ingrid Alfheim
The Research Council of
Norway
Stensberggaten 26
P.O. Box 2700 St Hanshaugen
N - 0131 OSLO
Tel +47 22 03 70 00/
Tel +47 22 03 75 06
Fax +47 22 03 70 01/
Fax +47 22 03 73 07

PORTUGAL

Mr. José Eduardo Isaac-Duarte
Junta Nacional de
Investigacao Cientifica e
Tecnologica (JNICT)
R. das Praças,13-B, R/C
P - 1200 LISBOA
Tel +351 1 605 006
Fax +351 1 395 09 79

Eng. Angela Reis
Instituto Nacional de
Engenharia e Tecnologia
Industrial (INETI)
Pr. Principe Real 19
P - 1200 LISBOA
Tel +351 1 347 45 08
Fax +351 1 342 33 62

RUSSIAN FEDERATION

Mr. Nickolai B Popov
Dept of International
Scientific and Technological
Cooperation
Ministry of Science and
Technological Policy of Russia
11 Tverskaya str
RUS - 103905 Moscow
Tel +7 095 229 2629
Fax +7 095 230 2660

SPAIN

Mr. Andres Zabara
Centro para el Desarrollo
Tecnologico Industrial (CDTI)
Edificio Cuzo IV
Paseo de la Castellana 141, 12°
E - 28046 MADRID
Tel +34 1 581 55 00
Tel +34 1 581 56 07
Fax +34 1 581 55 76
Fax +34 1 581 55 84

SWEDEN

Mr. Erik von Bahr
Swedish National Board
for Industrial and Technical
Development (NUTEK)
S - 117 86 STOCKHOLM
Visitors: Liljeholmsvägen 32
Tel +46 8 681 94 37
Fax +46 8 681 95 16

SWITZERLAND

Dr. Peter Kuentz
Swiss EUREKA NPC-Office
Monbijoustrasse 28
P.O. Box 7023
CH - 3001 BERN
Tel +41 31 322 21 46
Fax +41 31 382 37 01

TURKEY

Prof. Dr. Mehmet Tomak
TÜBITAK International
Relations
Atatürk Bulvarı No: 221
Kavaklıdere
TR - 06100 ANKARA
Tel: +90 312 467 76 49
Fax: 90 312 427 74 83 /
Fax: 90 312 427 26 72

UNITED KINGDOM

Mr. Graham Crewe
EUREKA Office, DTI
151 Buckingham Palace Road
GB - LONDON SW1W 9SS
Tel +44 71 215 16 81
Fax +44 71 215 17 00

EUREKA SECRETARIAT

Avenue des Arts 19H
Boite 3
B - 1040 Brussels
BELGIUM
Tel +32 2 217 00 30
Fax +32 2 218 79 06



