



Commission of the European Communities

# information management

## **One century of technical progress based on an analysis of German patent statistics**



**Report**

EUR 11044 EN

Commission of the European Communities

# **One century of technical progress based on an analysis of German patent statistics**

J. Sláma

Osteuropa – Institut  
Scheinerstraße 11  
D – 8000 München 80

Directorate-General  
Telecommunications, Information Industries and Innovation

1987

EUR 11044 EN

**Published by the  
COMMISSION OF THE EUROPEAN COMMUNITIES  
Directorate-General  
Telecommunications, Information Industries and Innovation  
Bâtiment Jean Monnet  
LUXEMBOURG**

**LEGAL NOTICE**

Neither the Commission of the European Communities nor any person acting on behalf of the Commission is responsible for the use which might be made of the following information

Cataloguing data can be found at the end of this publication

Luxembourg: Office for Official Publications of the European Communities, 1987

ISBN 92-825-7483-0

Catalogue number: CD-NA-11044-EN-C

© ECSC-EEC-EAEC, Brussels · Luxembourg, 1987

*Printed in Belgium*

## CONTENTS

INTRODUCTION	1
Part I .....	5
The German Patent Classification	7
Notes referring to part I	15
Part II .....	23
Factors Influencing Trends in Patent Applications and Possible Interpretations	25
Notes referring to part II	37
Part III .....	53
Statistical Analysis and Interpretation of Trends in Patent Applications	55
CONCLUSIONS	99
Literature and References	107
Annex : Report EUR 7872 EN	117
Introduction	119



1. Total Patent Applications and Grants, broken down into Nationals and Foreigners in Germany for the years 1877 - 1980	121
2. Total Applications in Germany broken down by Classes of the German Patent Classification in the years 1881 - 1973	133
3. Development in the Individual Patent Classes in Absolute numbers of Patent Applications in Periods of Two Years (from 1882 - 1974) and Proportions of Total Patent Applications in 1/1000 in Classes 01 - 89	159
4. Patent Classes of the German Patent Classification (as of 1974)	357
SUBJECT INDEX	363

## INTRODUCTION

This study looks at trends in patent applications in Germany and the Federal Republic of Germany in the last 100 years. The data and diagrams were published by the author in 1981 \*).

The main aims of the analysis of these data are as follows :

1. Using the time series of patent applications, trends in the production of technological know-how are described for various sectors - grouped in the 89 patent classes - over the period from 1877 to 1973 or 1980.
2. On the basis of trends in patent applications, the typical behaviour patterns in technological development are identified and a number of hypotheses regarding behaviour in the technology sector are formulated and tested.
3. On the basis of the analysis of trends in patent applications, the influence of exogenous (i.e. economic, social, etc.) and endogenous (i.e. relating to science and its laws) factors on technology is determined.
4. In addition, the patterns of structural development of the technology sectors are determined and the structural influences of technological change on the trends in patent applications as a whole are identified.

---

\*) *"Trends in the filing of patent applications in Germany/the Federal Republic of Germany between 1877 and 1980"* (Report EUR 7872EN).  
A copy of this report is included (see from page 117 to 362).

## 6 ONE CENTURY OF TECHNICAL PROGRESS

5. On the basis of the analysis of patent applications, the relationship between long- and short-term trends and fluctuations in the economy and economic development are shown in relation to technological development.
6. On the basis of the statistical analysis of the time series of patent applications, the time sequence of the technology sectors is determined in relation to their growth - both in qualitative and in quantitative terms.

KAISERLICHES PATENTAMT.

# PATENTSCHRIFT

**N<sup>o</sup> 46.**

**E. R. MINARD und A. P. MINARD**  
IN PARIS

**SCHRAUBENTÜLLE FÜR LEUCHTER.**



Klasse 4  
BELEUCHTUNGS-GEGENSTÄNDE.



BERLIN

GEDRUCKT IN DER KÖNIGL. PREUSS. STAATSDRUCKEREI.

F. R. MINARD UND A. P. MINARD IN PARIS.

Schraubentülle für Leuchter.

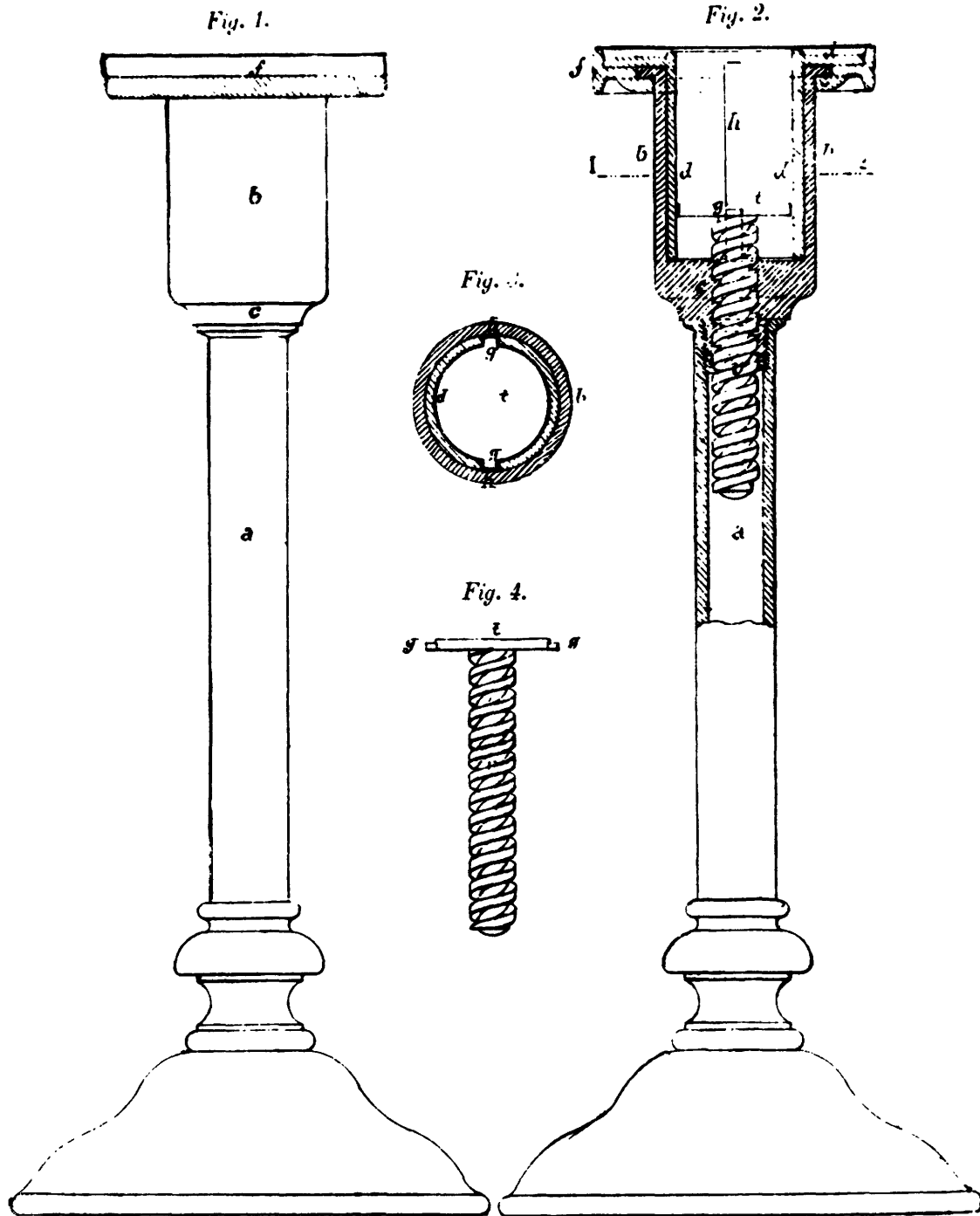

Zu der Patentschrift

**N<sup>o</sup> 46.**

PHOTOGR. DRUCK DER KONIGL. PREUSS. STAATSDRUCKEREI.

PART I



## Part I

### THE GERMAN PATENT CLASSIFICATION

The statistics of patent applications and grants in Germany, beginning in 1877, form the empirical basis for this study. In that year (on May 25) the Patent Law for the German Reich was passed and the Imperial German Patent Office set up :

*"The first unified German (Reich) Patent Law, which came into force on 1 July 1877, was the result (for which hope had long since been given up) of a long period of difficult struggle to reform the various German patent laws and licensing regulations and later to maintain and codify a better (more practicable) new patent law. The conflict of opinions for and against patent protection as such was thus resolved. The battle against the supporters of the German doctrine of free trade under the leadership of John Prince-Smith and against the Prussian ministerial bureaucracy - led principally by the Prussian ministers von der Heydt and Graf von Itzenplitz and the latter's chief of division Rudolf Delbrück who saw invention patents as a hindrance to unrestricted freedom in international trade and therefore attempted to abolish patent protection altogether - was thus won. The German legal system now possessed, in addition to the 1870/ 1871 law of copyright on writings, illustrations, musical compositions and dramatic works and the laws of 9.10.11 January 1876 on the protection of works of the visual arts and photographs and the law of copyright on industrial patents and models, a statutory regulation for the protection of commercially exploitable technical inventions as a further part of industrial legislation. This created the conditions for the upswing in German industry, which had been so necessary since the world economic crisis of 1873 and had become a matter of extreme urgency in view of the expiry of the trade agreements with the major neighbouring countries and America. The protection of domestic production against the fierce competition from other countries was ensured and German inventors were once again given the incentive to make the latest technical inventions available to domestic industry*



*again and thus put an end to the state of imminent 'intellectual impoverishment' in trade and industry" \*)*.

The Patent Office published the classification of patents in Volume 2 of the "*Patentblatt*" founded in the same year. This classification listed 89 patent classes, designed to cover all sectors of inventive activity. It says something for the foresight of the authors of this patent classification that the classes have been valid for almost 100 years with only very few changes.

The changes made in the classification of patents in these 100 years are instructive and must themselves be regarded as empirical material for analysing technological development. The most important changes made in the patent classes are described below.

In the first list of patent classes, Class 7 was designated "Production and processing of sheet and wire". At a later date this class was significantly extended and renamed; since the beginning of this century it has been called "Mechanical metal working without essentially removing material; punching metal".

Patent applications in the field of aviation were already covered by the 1877 classification but in Class 77 "Sports". The full name of this class was "Sports, games, gymnastics, skating, hunting & fishing, airship navigation". In the 1920s a special patent class was created for aviation, namely Class 69, which originally covered patent applications for the saltworks industry. At the beginning of this century the contents of Class 43 was also changed from basket and wickerwork to checking devices.

The contents and title of Class 63 were also changed. It was originally called "Saddlery and carriage-making" but later became the class covering patent applications in the field of trackless vehicles.

There was also a change in the contents of Class 75 "Soda, potash and alkalis", which after a number of years as a separate class was transferred to Class 12 "Chemical processes". Class 75 then covered inventions in the field of sculpture, painting and ornamentation of surfaces.

Class 85, originally entitled "Water pipes, baths, toilets, sewerage", was subsequently extended to cover "Mineral and soda water, water purification, water supply and sewerage".

Many classes were extended over the years. They include the following : Class 31 "Casting" to which powder metallurgy was added. Class 56 - originally "Harnesses" - was converted into "Upholstery and saddlery". Class 57 - originally covering photography - later incorporated cinematography and sound film. Class 60, originally called "Regulators for engines", was later changed into "Fluid-pressure actuators; hydraulics and pneumatics".

---

\*) R. Nirk, "*100 Jahre Patentschutz in Deutschland*", in "*Hundert Jahre Patentamt*", Munich, 1977, p. 345.

Class 88, originally covering machines driven by wind or water power, was later extended to include electrophysical and nuclear reaction drives and photon drives.

The German patent classification corresponds fairly closely to the branch structure of production. It is also highly user-orientated, thus making it easier to analyse the relationships between technology and economic trends. This means that in drawing up the patent classes and classifying patent applications greater importance was attached to the branch in which the invention can be used, rather than the branch of origin. This is brought out very clearly in the case of mechanical engineering. The inventions pertaining to various machines used in different branches are not classified under mechanical engineering but under the relevant user branch, e.g. baking machines in the class "Baking", looms in the class "Weaving", etc.

In principle, three main groups of patent classes can be distinguished in the German patent classification :

1. The primarily product-orientated classes, such as wearing apparel [1] \*), brushware, steam boilers, footwear, musical instruments, etc. These product-orientated classes are in many cases broken down into subclasses covering machines, processes and product design.
2. There are also many primarily process-orientated classes, such as zymology [2], surface treatment of metals, sewing and embroidering, grinding and pulverizing, presses, etc. These process-orientated classes likewise cover machines for carrying out the processes.
3. A few classes are raw material-orientated, such as wood working [3], preparation of ores and other minerals, etc.

The grouping of patent classes according to the above criteria does not mean, however, that individual classes do not at the same time comply with different criteria, owing to the relationships between raw materials, processes, their treatment and products. In many cases, the type of raw material has a great influence on the process, treatment and products and vice versa.

Certain products can be made most rationally from particular raw materials by particular processes. In determining the order of the patent classes in the list, the authors avoided a complicated problem in that they did not make it subject to substantive criteria, e.g. the criterion of the processing of the raw material and hence the sequence from primary to final production. In contrast with the international patent classification now in force, the German patent classification adopted the formal criterion of alphabetical order. This decision can hardly be criticized. A one-dimensional order can take only one criterion into account to the exclusion of others.

---

\*) For the notes in square brackets [ ], see pp. 16 - 19.

Another important question is that of the homogeneity or heterogeneity of individual patent classes. This question is particularly relevant to the aim of this study, namely the empirical testing of the hypotheses of technological behaviour patterns. It is obvious that the hypotheses formulated for homogeneous areas of technology can hardly be tested on a heterogeneous mixture of different areas. On the other hand, it is clear that all classes of the German patent classification - even the most heterogeneous - contain an element of homogeneity. This does not mean, however, that all the time series of German patent applications are equally suitable for empirical testing of the various hypotheses mentioned before. The empirical statistical material is, however, so extensive and varied that there is a sufficient number of homogeneous classes for thorough testing of the hypotheses formulated.

The disaggregation of the whole of the technology sector into individual patent classes is not only a question of substantive criteria but also the result of certain arbitrary decisions. This can be illustrated by the example of lighting. It is conceivable that a single class can be created for the technological problems of lighting. The sequence and rivalry of different lighting principles and technical solutions leading to the performance of the lighting function would in this case take place within this one class. The transition from the oil lamp via gas lighting to electric lighting would be reflected in the trend in the number of patent applications in this one class. In the German patent classification, however, lighting patents were included mainly in two classes :

1. in Class 4 "Lighting through fuels and pre-heating torches" [4], and
2. inventions in the field of electric lighting were included in Class 21 "Electrical engineering" [5].

Even though further subdivisions of the statistical series in Class 21 were not available, it was nevertheless possible to identify the relationship between electric and gas lighting by the trend in patents in Class 4. Problems of this kind often occur in analyses of trends in patent applications and can in some cases be solved by means of additional information. In any event, the problems such as those connected with the heterogeneity of the classes have to be taken into account in interpreting the empirical results.

Experience has shown that trends in very heterogeneous and broad patent classes can also provide a whole series of valuable data and conclusions.

The two broadest patent classes are Class 12 "Chemical processes and apparatuses" and Class 21 "Electrical engineering". It would certainly be very difficult to provide a detailed interpretation of trends in patent applications in these two classes. In order to explain the short- and medium-term fluctuations of patent applications in the aggregates of these classes, a vast amount of additional information would be required.

In this connection it must be emphasized that the statistical material is available only at the level of patent classes and cannot be broken down any further. It was nevertheless possible, without going into the short- and medium-term fluctuations, to identify long-term trends in these two areas and determine a time sequence for both classes in accordance with the afore-mentioned logistic hypothesis.

The German patent classification was valid for the period from 1877 to 1974. The last data based on this classification were published for the first half of 1974. Since then, the data on patents and applications forming part of the German Patent Office's statistics have been published only according to the international patent classification. There is, however, a connection between the German and the international patent classification. Some classes in the former correspond to classes in the latter. As a result, some of the series of patent applications could be compiled beyond 1974 to the present time. There are almost 30 classes for which the study goes as far as 1980.

*Development of the Patent Classification as a Means of Identifying Technological Trends*

As already mentioned before, the development of the patent classification is a rewarding subject for study. In the light of the development of the patent classification, changes of the classes and the formation of new subclasses, the technological changes can also be analysed and identified.

The Patents Office's changes of the classification were obviously linked to changes of the volume of applications. Certain changes were called for if the number of patent applications had fallen or risen in the long term or if within a class a certain area had become prominent as a result of a long-term increase of the number of patent applications.

The Patent Office made the changes of the patent classification either on a case-by-case basis in decisions concerning only individual classes or as part of a general revision of the classification. Various Patent Office papers and documents published under different titles dealt with the classification of patents. In many cases, the title "Gruppeneinteilung der Patentklassen" was used for the document in question. In addition to this group classification of patent classes, the classification was also published under the title "Verzeichnis der Patentklassen nebst Unterklassen".

The classification of patents was also the subject of another Patent Office document, namely the "Alphabetisches Stichwörterverzeichnis zum Verzeichnis der deutschen Patentklassen und ihre Einteilung in Unterklassen und Gruppen".

This document too appeared in a number of issues dealing with developments in technology, innovation and the number of patent applications.

In connection with the changes of the patent classification, other aids were frequently published, such as the comparison of the new patent classes with previous ones or hints to facilitate determination of the relevant patent classes.

The first major amendment of the patent classification was made in 1900. Further revised editions were published in 1905, 1926, 1933, 1949 and 1958.

Trends in technological developments of the past could be identified by comparing various editions of the patent classification.

A detailed analysis of this type would, however, be beyond the scope of the present study. It is nevertheless not out of place to mention the possibilities of an analysis of this type.

A. DE BOISCHEVALIER IN STOLBERG BEI AACHEN.

Klüttenformungs-Apparat für Braunkohlen.

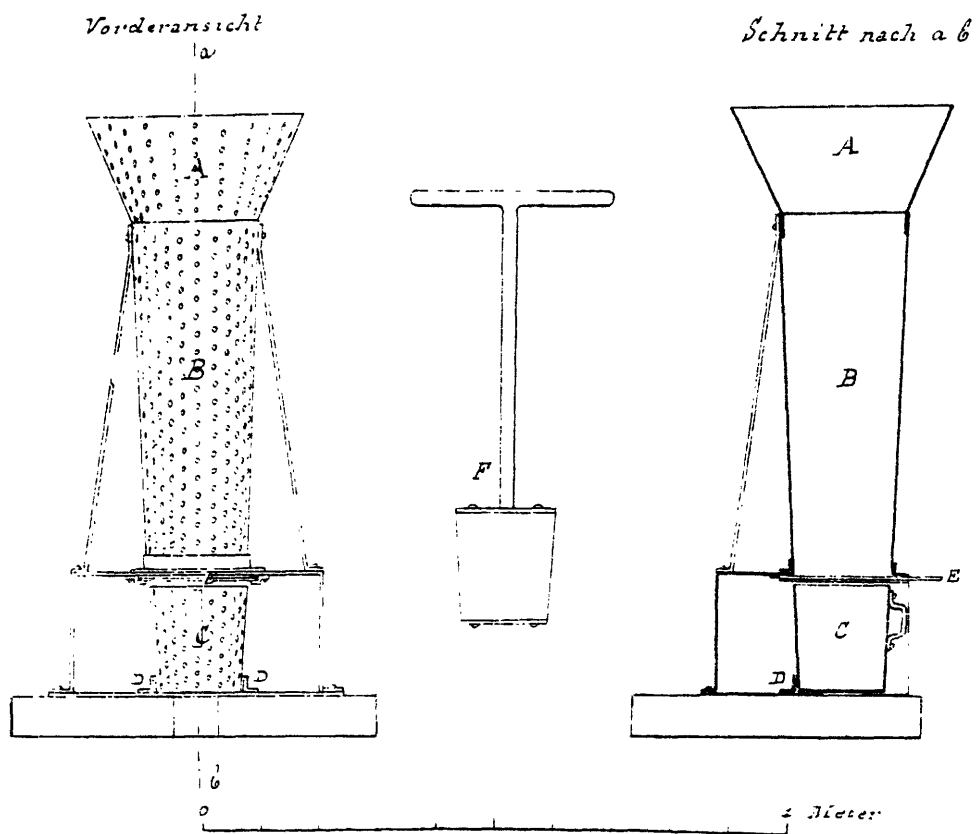

Zu der Patentschrift

№ 160.

PHOTOGR. DRUCK DER KÖNIGL. PREUSS. STAATSDRUCKEREI.

EDWARD STANLEY BOYNTON IN NEW-YORK.

Verfahren zum Buchbinden.

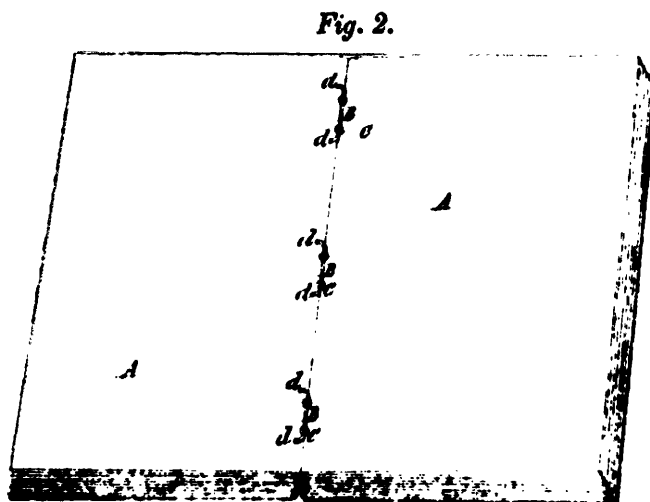
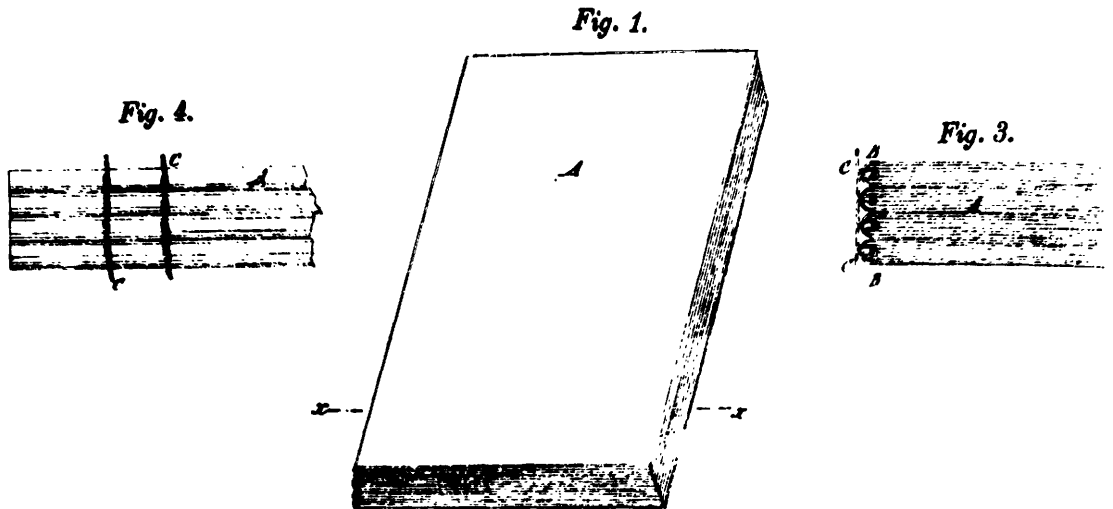

Zu der Patentschrift

№ 55.

PHOTOGR. DRUCK DER KÖNIGL. PREUSS. STAATSDRUCKEREI.

NOTES REFERRING

TO

PART I



## NOTES REFERRING

TO

## PART I

[1] "Class 3 Wearing apparel (headwear 41; footwear 71; braiding, lace-making, knitting, trimmings, non-woven fabrics 25; sewing and embroidery 52; weaving 86).

3a Linen, including non-perishable and paper linen, mechanical part (chemical part 8k), underwear, stockings, corsets.

3b Articles of clothing, including braces, ties, gloves, hat holders attached to the hat, etc. and accessories, materials for garments, provided they do not come under 25 or 86.

3c Fastenings (string fastenings 71b, 1 - 4).

3d Tailoring aids (for the manufacture of linen 3a, 7; sewing machines 52a, 58 07-58 10).

3e Artificial flowers and fruits, false hair, working of birds' feathers and artificial feathers to produce garments, articles of clothing made from finished natural and artificial furs (furrier's machines 18b)." \*)

[2] "Class 6 Zymology : alcohol, spirits, beer, wine, vinegar, yeast and other fermentation agents and products, enzymes.

6a Malt, hops, yeast, other fermentation agents.

6b Mash and wort, preparation and fermentation; distillation and redistillation of alcoholic and fermented fluids.

---

\*) "Taschenbuch des gewerblichen Rechtsschutzes", Munich, 1955, pp. 91 - 92.

- 6c Preparation of wine, sparkling wine and liqueurs (maturing of wine 6d, 6).
- 6d Preservation, fining, maturing.
- 6e Preparation of vinegar (wood vinegar 12r, 2; acetic acid 12o, 12).
- 6f Cleaning of barrels, tarring and detarring devices, barrel cauterizers, grooving devices, fermentation butts, wine cellar equipment, coatings for fermentation, storage and transport containers (brewer's pitch 22h, 8)." \*)

[3] "Class 38 Wood working by mechanical and chemical means.

- 38a Saws for wood working (saws combined with other wood working machines 38b 7; protective devices 38c; metal saws 49c; for butchery 66a; stone cutting 80d; equipment for felling trees by sawing, etc. 45f, 19).
- 38b Planing, drilling, shaping and turning of wood, including universal machines (tools 38e; metal working 49a, b, c).
- 38c Veneering and manufacture of plywood, smoothing of wood by grinding and polishing (polishes 22h; ornamentation 75), manufacture of laths from wood and mitre joints, framing devices (refinement of laths, gilding, varnishing 75).
- 38d Manufacture of dovetails, tenons, crates, suitcases and boxes, including caulking and nailing machines.
- 38e Tools, auxiliary engines and protective devices.
- 38f Bending of wood, manufacture of wooden barrels and wheels.
- 38g Mechanical working of cane, cork and the like.
- 38h Methods, processes and devices for drying and waterproofing, e.g. hardening, preserving, fireproofing, dyeing and staining of wood, cane cork and similar substances (pesticides in general 45l, 3 ol, coating materials for wood 22g, 6 ol; varnishing processes for wood 75c, 5 o2).
- 38i Bark stripping, manufacture of veneers, woodchips, wooden wire and wood wool.
- 38k Processes and machines for working wood for special purposes and special objects.
- 38l Manufacture of 'plastic wood' from wood fibres or wood waste, provided the wood component is predominant (boards for building purposes 37b, 2 o2, manufacture of boards from pulp, including hardboards, mechanical

---

\*) "Taschenbuch des gewerblichen Rechtsschutzes", Munich, 1955, p. 6.

part 54e, 1; chemical part 39b, 55c; building materials with inorganic binders and asphalt 80b; substances with organic binders 39a, 39b) without groups." \*)

[4] "Class 4 Lighting through fuels and pre-heating torches

- 4a *Lanterns, miner's lamps, chandeliers (Christmas tree lights 34l), flares, lamp accessories (burners 4g) and light holders.*
- 4b *Lighting, including lighting independent of the type of light source.*
- 4c *Gas holders (construction 37f), pressure regulators in the mains and consumption regulators for lighting and cooking purposes (gas pressure regulators for gas engines 46c 1,1; firing regulators 24c), by-pass regulators for compressed-gas installations (by-pass regulators for gas-producing furnaces 26a), piping and distribution of gaseous fuels, gas and air mixes etc. for gas works (gas mixtures 26c), installations for the production of compressed gas (gas pipes in railway carriages 20c, 27; in coke ovens 10a, 20; valves, taps, gate valves 47g; gas pressure regulators for general use 47g 2).*
- 4d *Ignition and extinguishing systems, including electric, provided they do not involve switches (switches 21c; catalytic gas self-igniters and their manufacture 4e).*
- 4e *Catalytic gas self-igniters (fitting of catalytic gas self-igniters to gas lamps, heating burners, etc. 4d, 1-3; pyrophorous metals and alloys 44b; 78f).*
- 4f *Incandescent mantles.*
- 4g *Burners (burners for gas firing 24c; for heating and cooking stoves 36b; for metallurgical furnaces 18b, c, 40a, d; for distillation furnaces 10a, 5; for firing with liquid fuels 24b; for singeing machines 8b) and carburetors for liquid fuels, provided they are combined with a burner (independent carburetors for liquid fuels 26a, c; carburetors forming part of an engine 46c 2). Disposition of the burner in the lamp and connection of the burner to other parts of the lamp in order to increase its efficiency."\*)*

[5] "Class 21 Electrical engineering.

- 21a *Electrical transmission of news and messages.*
- 21a<sup>1</sup> *Electrical telegraphy.*
- 21a<sup>2</sup> *Telephony and electrical-acoustical sound recording and reproduction (sound recording and radio telephones 42g).*

---

\*) "Taschenbuch des gewerblichen Rechtsschutzes", Munich, 1955, pp. 92 - 93.

- 21a<sup>3</sup> Telephone exchanges.
- 21a<sup>4</sup> Transmission of news and messages by means of high-frequency electrical oscillations.
- 21b Galvanic cells, accumulators and thermocouples.
- 21c Electric lines and installations; cables and overhead transmission lines, insulators, switches, regulators, switching systems, line protection, fuses and lightning conductors.
- 21d<sup>1</sup> Direct current.
- 21d<sup>2</sup> Alternating current.
- 21d<sup>3</sup> Special systems independent of the type of current.
- 21e Equipment for measuring electrical quantities.
- 21f Electric lighting.
- 21g General electrical auxiliary equipment and processes other than electrochemical; magnets, automatic cutouts, condensers; rectifiers, discharge tubes, X-ray apparatuses, electro- and radiotherapy equipment, photoelectric cells.
- 21h Processes and equipment for electric heating, cooking, melting, welding and soldering." \*)

---

\*) "Taschenbuch des gewerblichen Rechtsschutzes", Munich, 1955, pp. 102 - 103.

VICOMTE DE CALONNE IN PARIS.

Buchrecher-Schützen.

Fig. 2.

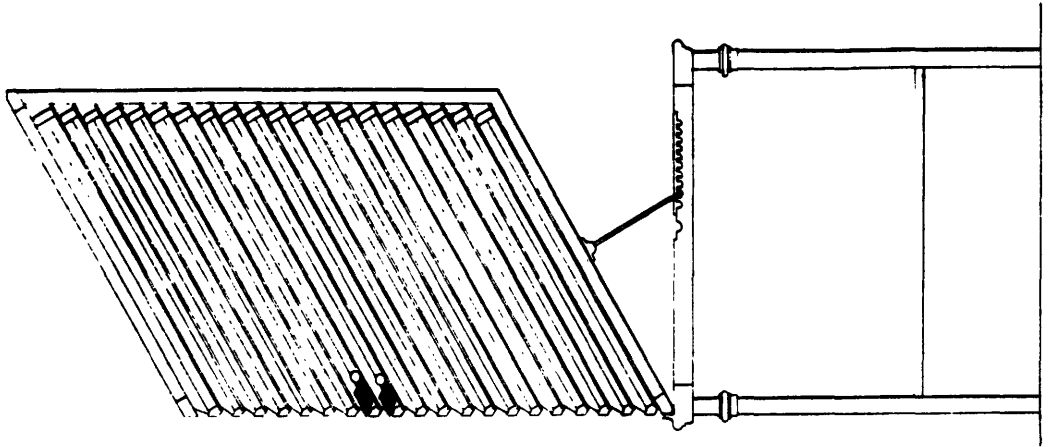

Fig. 1.

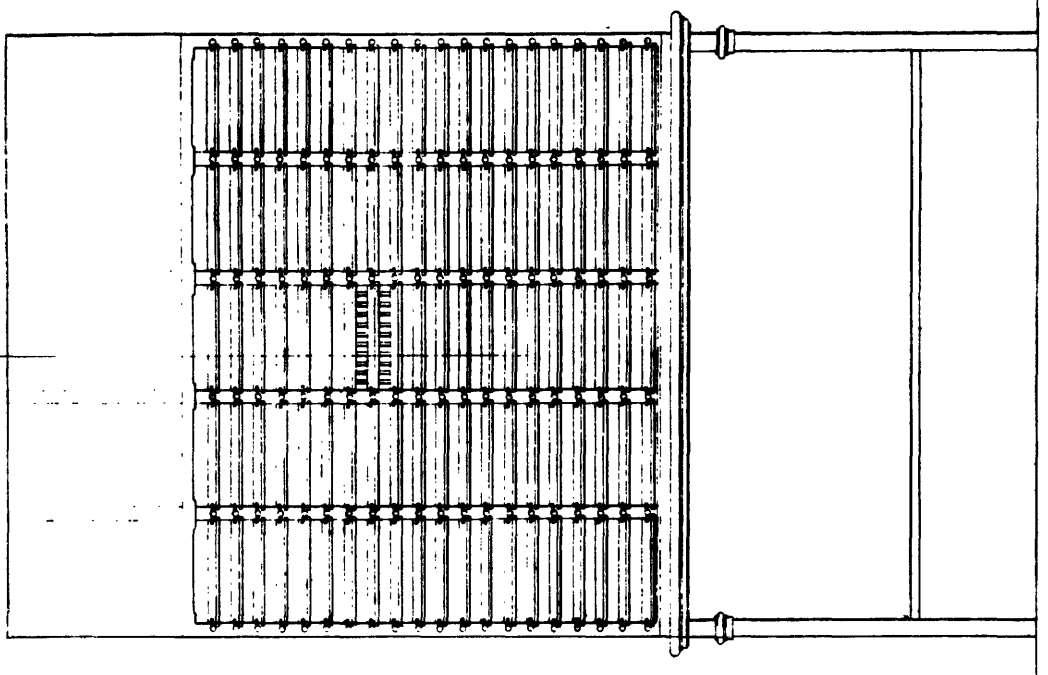
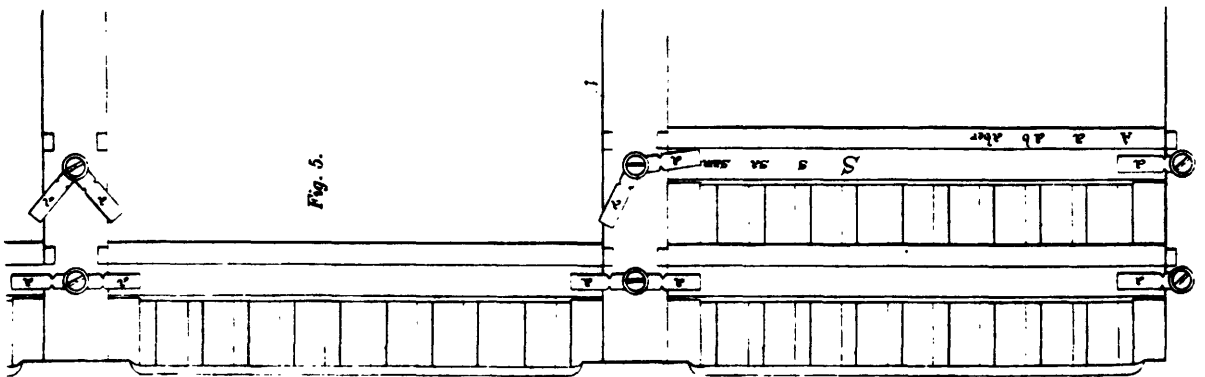
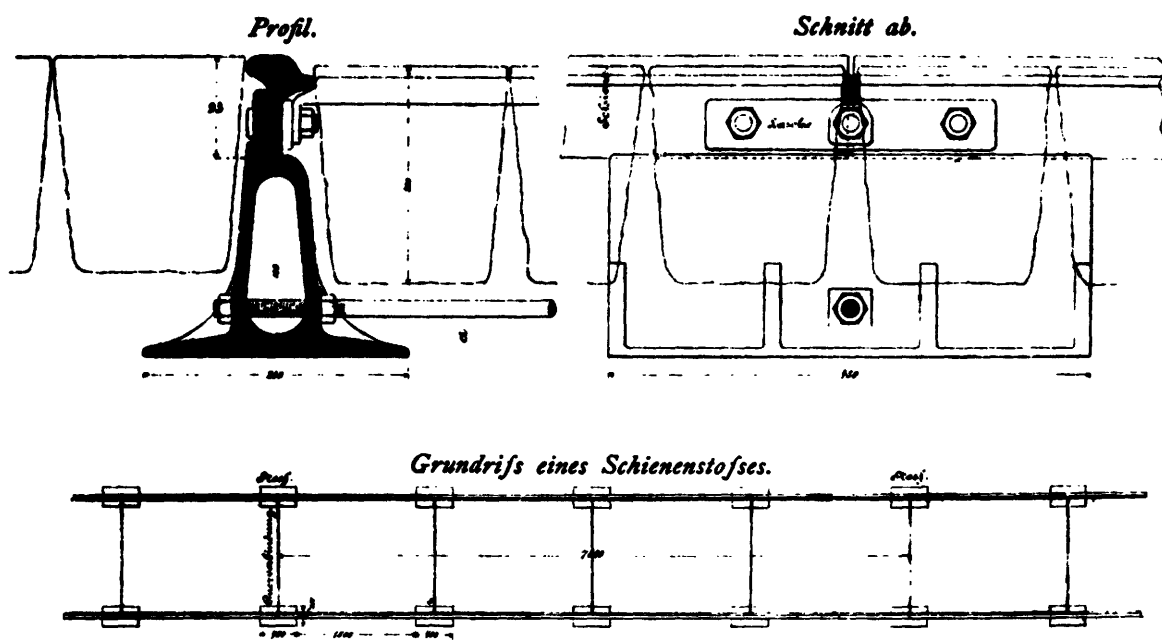

Fig. 5.



PHOTOGR. DRUCK DER KÖNIGL. PREUSS. STAATSDRUCKEREI.

EMIL BÖTTCHER IN BREMEN.  
Eiserner Oberbau für Strassenbahnen.



Zu der Patentschrift

№ 113.

PHOTOGR. DRUCK DER KÖNIGL. PREUSS. STAATSDRUCKEREI.



PART II





## Part II

### FACTORS INFLUENCING TRENDS IN PATENT APPLICATIONS AND POSSIBLE INTERPRETATIONS

In view of the very rudimentary theory of inventions (Knut Borchardt) and the scanty treatment of the problems of technology in the economic and social sciences, it is extremely important to examine empirical data that describe technological development not as a series of individual discoveries but as a wide stream of millions of occurrences. This empirical material is represented by the German patent statistics, which show the data for the last 100 years of patent applications broken down into 89 classes covering the different areas of technology and production. These patent applications were filed by both nationals and foreigners, the proportion of the latter being considerable at all times. Because of Germany's involvement in international economics and technology, it is therefore right to regard these data series as a reflection of technological development not only in Germany but throughout the world.

#### *Some Methodological Problems*

The long-term trends in patent applications can be studied in various ways firstly, patent applications can be taken as the starting point for the study in an attempt to determine what technological, economic, political and other developments and processes are reflected in the trend in the number of patent applications. With this approach, the whole range of information and interpretations offered by trends in patent applications is covered and all the relevant data are evaluated.

Another possible way of analysing trends in patent applications involves formulating certain hypotheses about technological and other developments as a starting point for the study and then trying to confirm or refute these hypotheses on the basis of the empirical data concerning trends in patent applications all along. In this case, the starting point for the study is a more or less consistent theoretical conception of the relationships and laws of development of a particular area of technology;

this theoretical conception is then expressed in the hypotheses tested empirically. An occasional disadvantage of this approach is that the assumed relationship may not exist between the hypotheses tested and the empirical data available.

There is a clear justification for both approaches and they are by no means mutually exclusive. On the contrary, various dangers can be avoided by combining them, e.g. an abstract ad hoc interpretation of the empirical data or a loss of the patent information and research potential of the empirical data. However, it may also happen that the questions are correct and the theory tallies with reality, while the choice of the empirical data is wrong; the empirical data used are not suitable for testing the theory and hypotheses in question.

In this study the two approaches are combined. At all times, both questions are put and an attempt is made to answer both, namely the question as to which processes are reflected in the trends in patent applications and the other question aimed at testing certain hypotheses of technological and industrial development.

The two approaches can also be combined because this study represents a point of intersection between different scientific disciplines and different methodological approaches. On the one hand, this study can be regarded as part of historical research, in particular economic and social history of the history of technology or scientific development. On the other hand, this study deals with questions pertaining to economic science and touches on the theories of both economics and business management. Certain problems and hypotheses can be regarded as part of natural and technical sciences, in particular of their general sectors. Last but not least, this is also a study of creative human endeavour, which can certainly be regarded as the subject of various anthropological disciplines.

The outline given here of various theoretical and methodological approaches should also give an idea of the wide scope of a study of trends in patent applications.

#### *Empirical Value of Trends in Patent Applications*

It can be justifiably maintained that the data on trends in patent applications represent such valuable empirical material that a narrow approach to the problems involved in studying them would be to neglect important research potential.

Another aspect of the study is the usefulness of devising certain approaches and instruments which would play a significant part in the drawing up of technical and technological predictions. Both in history as a whole and in the history of technology, periods of continuous evolutionary development alternate with revolutionary breakthroughs or leaps from a qualitatively lower level to a higher one. Examination of past trends shows the situations and conditions reflected in an evolutionary development and also the conditions that lead to revolutions - in our case, to technical and scientific revolutions. [1] \*)

The study of relationships of this type can make it easier to draw up technical forecasts and to assess technical trends in imminent technical breakthroughs. However, the information can scarcely be regarded as conclusive, although the level of uncertainty can be reduced from one case to another in the light of knowledge of past developments.

It is certainly not the aim of this study to make generalizations of the substantive aspects of patents and the concepts and terms used in patenting. In this connection, a number of assumptions must be made here. On the other hand, in a study of trends in patent applications discussion of the information value of patent applications and their numbers, touching also on the general problems of patenting, cannot be avoided.

Of fundamental importance in this respect is the relationship between the invention, which must be considered in the context of technological and social developments, and the patent application relating to that invention. Every invention contains an element of human curiosity and the answer to the questions : what, why and how?

#### *Economic Aspects of Inventions and Patent Applications*

Every invention also raises the questions of the work involved and the yield, input and output, expenditure and revenue, cost, price and profit. Of importance here are both the cost involved in the development of the invention and the cost incurred in patenting and the patent application and finally the cost and benefits associated with the use of the invention.

The questions of cost and benefits mean that inventions are subject to economic considerations. In this way, the part played by considerations of economics, business management and orderliness in the field of inventions and patent applications is increased and the proportion of random and purely individualistic elements decreased. As a result, trends in patent applications can be made the subject of systematic scientific research, particularly in the context of the social and economic sciences.

For the purposes of further study, it is important to bear in mind the two major areas of the economic effects of inventive activity and discoveries firstly, the questions associated with the expenditure for the invention and, secondly, all the initially anticipated and subsequently actual economic effects of inventions in the event of their application and once again both the positive and negative effects of cost and benefits. Of importance in this connection is the comparison of production cost, with or without utilization of certain inventions, and the benefits arising from their application.

---

\*) For the notes in square brackets [ ], see pp. 38 - 50.

When a technical project is planned, started and carried out, not very much is known about the actual or potential results and even less about the economic effects of using these results. The research is not carried out in the sure knowledge of the results but with certain expectations. The element of certainty may differ from case to case. There are projects whose results are easy to predict and others whose results are very uncertain. The only constant factor are the venture and the risk closely linked to the significance of the desired results.

The scale of research and inventive activity may depend both on the available funds and on the anticipated effects. As a rule, it is impossible to say in individual cases which factor is paramount. In this context it is important, for example, how expensive the whole project is : how great are the risks of failure, of unsuccessful endeavour, how high are the hopes placed in the desired results, how great is the pressure of the market and competition, and how sound are the project's finances?

At the level of the national economy, one hypothesis that can be put forward is that the production of new technological knowledge and inventions, and therefore patent applications too, depends primarily on the pressure of demand, the need to open up new markets, possible cost savings, etc. The question is whether there are more research and innovation or more use is made of existing inventions at a time of crisis or economic decline or during a boom period.

A further explanation is provided by a relatively trivial factor. It is assumed that the amount of research activity is determined primarily by the allocation of funds, which is dependent on the general economic situation.

An initial glance at the trend in the total number of patent applications confirms that research, and therefore also the production of technological know-how and the number of patent applications, is highly dependent on trends in the general economy [2]. As already stated, the main reason for this dependence are the funds available for research, which differ from one phase of the economic cycle to another. Some differences must be expected, however, between trends in research and the economic cycle.

In the phase of great economic activity and demand pull, the pressure for the qualitative improvement and rationalization – on the basis of technological development – of production is not so great. During this period, use is made above all of the potential for a quantitative increase in production, which to some extent can also, however, be brought about by technological research and development. This determines the overall direction of research and development objectives. The technologically determined rationalization measures which will lead to a reduction in cost may be very useful in this situation, particularly if in this way certain shortages in the human or material factors of production can be overcome.

A further aspect of the general dependence of research on the economic situation concerns the special nature of research capacities and the relevant human resources. Research workers are highly qualified staff whose training and qualification require a lot of time and considerable expense not only outside the company but also, and above all, during their career within the company.

In contrast with the situation with factors of production that can be acquired in the short term, companies are in this case under considerable pressure from future situations and expectations. Experience has shown that the shortage of highly qualified staff, who are difficult to afford in times of crisis, can have a decisive effect on shaping the company's future situation. However, not only the future is at stake : although in a time of crisis it is necessary to make savings and lay off workers, the intensified competition makes it imperative to safeguard the chances of survival of the company, industry, etc. through research and technological development.

A further special relationship between the economic situation and the trend in patent applications arises from the fact that the financing of research is not reflected until some time later in inventions and patent applications. As a result, a reduction of the number of patent applications follows a decline in production with some delay.

The above remarks indicate that in the interrelationship between economic trends and research and the production of technological know-how the leading part is played by economic trends. At different times, these give rise to a differing level of both demand for innovation and pressure on research to meet economic needs through inventions. In other words, research and the production of technological know-how are regarded not as an exogenous factor which develops independently of the economy and exerts a strong influence on it but as a part of the economic system, as an endogenous factor which is affected by economic trends.

The leading part played by economic trends in the field of inventions and patent applications is reflected both in the total number and in the breakdown of patent applications. The trend both in the overall figure and in individual patent classes reveals at first sight a high degree of dependence on economic trends.

A high degree of dependence on economic trends and economic and social conditions is characteristic of the emergence of new areas of technology and new production branches. However, it must be stressed in this particular context and also in general that the hierarchy of economic fluctuations (long-term trends, medium- and short-term fluctuations) is related to a corresponding hierarchy of technological development.

A technological revolution such as the development of a new production branch or a new area of technology cannot be interpreted as a reaction to short-term economic fluctuations. There is more of a connection with the recurring rise and fall of the economy, although this connection is not particularly close in the case of major breakthroughs. The exhaustion of the technical and technological potential existing at the particular time is certainly a factor behind technological and structural breakthroughs of this type. The very great pressure of demand from the economy and society ultimately brings about such a breakthrough. However, it depends on a whole series of factors whether the breakthrough takes 10, 15, 20 or more years.

*Endogenous Factors in Technological Development and Trends in Patent Applications*

The assertion made above that technological innovations cannot be regarded as an exogenous factor of economic trends does not mean that the sector of technological development and inventions does not have its own laws, constraints and relationships. Technological revolutions are a result of the demand and cost crisis (cost stagnation) but are at the same time an expression of the exhaustion of the technological potential of the relevant branches, areas of technology or even perhaps the whole national economy. The temporary exhaustion of this potential is one of the reasons for the stagnation of the economy and is ultimately overcome as a result of pressure from economic needs. In this context it is important to analyse and identify these signs of stagnation not only in the economy as a whole but also in the technology sector itself. The states of exhaustion which we surmise in individual areas of technology relate to much longer periods than the economic cycle. Whereas the upward and downward movements of the economy extend over a few years and the whole cycle lasts for perhaps 10 to 20 years, the ups and downs in individual areas of technology are to be measured in terms of decades or even centuries and millenniums.

An important question is whether the patterns of trends in individual areas of technology which are expressed in the above-mentioned exhaustion hypothesis, amongst other things, are also valid for technological developments as a whole. In any event, it would be wrong to assume that the relationships which have an effect in individual areas of technology can simply be automatically added together to produce similar trends in the overall economy and technology as a whole.

A relationship of this kind would exist only if, firstly, no new areas of technology were created and, secondly, the time sequence of such developments was the same in all existing areas of technology. Even if the second assumption were discarded, a general state of exhaustion of technology as a whole will not be obtained by adding together the trends in individual areas of technology when the signs of exhaustion occur at different times in different areas.

The hypothesis that the signs of exhaustion recur at the level of technology and the economy as a whole can be refuted by two different but related processes. Firstly, in an area of technology nearing its upper limit a technological revolution takes place and gives this sector new impetus. This is a development which brings about the transition from a logistic S function (S-shaped curve) to a sequence of S-shaped curves, i.e. a step function [3]. The other possible way of preventing the recurrence of the signs of saturation of individual areas of technology at the level of the economy and technology as a whole has already been mentioned above. It involves the creation of new areas of technology.

In some cases, the distinction between a breakthrough in an area of technology can only be distinguished arbitrarily from the creation of a new area. This is why we said that the two processes are related; the distinction is only a question of classification and convention, i.e. a formality.

### *Problems of the Empirical Recording of Basic Innovations and Inventions*

The frequently practised breakdown of innovations and inventions into basic innovations and inventions and improvement innovations may well reflect the hierarchical structure of innovations and inventions with regard to their technological and economic significance and effect, but any attempt to chop up the continuity of technological development empirically is not likely to be very successful. In reality, technological development is dialectic : it is both continuous and evolutionary and discrete and revolutionary. Emphasizing one side at the expense of the other only leads to distortion of this reality.

The inappropriateness of the distinction between basic and improvement innovations is revealed in the first place if an attempt is made to record these two types of innovations empirically. This is possible only with a high degree of arbitrariness and subjectivity. The error is compounded if an attempt is made to attribute these types of innovations to different phases of the economic cycle and to distinguish the reasons for different types of innovations speculatively and then empirically. Ideas and observations of this type disregard time and time again the continuity of the innovation process.

### *The Number of Patent Applications as a Measure of the Production of Technological Know-How*

The use of the number of patent applications as a measure of the production of technological know-how involves a series of simplifications which have to be eliminated in a particular way [4].

Taking the number of patent applications as a measure of technological development disregards the differences between the individual patent applications and inventions. Applications and inventions are in fact very different things, one of them of fundamental and the other of marginal technical and economic significance. If no additional information on the quality of the patent application and inventions is used, there is a danger that only the continuity in the technological innovation process will be considered, with no account being taken of leaps and technological revolutions.

### *Hypotheses Explaining the Trends in Patent Applications*

For the purposes of this analysis in patent applications in Germany in the last 100 years, a number of hypotheses regarding technological developments were put forward and empirically tested. A brief outline of some of these hypotheses is given in the remainder of this section.

One of the most important hypotheses is that which describes technological development as a process which begins with major discoveries and invent-



ions and leads via the gradual exhaustion of research potential to an exhaustion limit and thus to the threshold of new breakthroughs [5].

Examples of such developments can be found in all areas of technology, e.g. aircraft construction, particularly the sequence of development of individual types of aircraft engine. The developments from one type of aircraft propulsion to another were always associated with significant increases in the speed achieved by the aircraft. A clear example of the behavioural pattern mentioned above is also provided by the development of weaving, in particular that of various types of loom. In this case too, the change-overs to new types of looms are associated with significant increases in working speed and efficiency of various types of machines.

The discovery and application of a new technological principle revolutionizes certain parts of production and process engineering. The greater the difference between the new and the old technological principle, the more difficult it is to grasp all the possibilities of the new principle and utilize them directly. Typically, a new principle disguises itself in the shape of the previous technological stage. Thus, the first motor-driven cars were none other than old coaches, albeit without horses and fitted with an engine. Various components of these coaches, which served a useful purpose only in association with the use of draught-horses and were of no use whatsoever to the motor-driven vehicle, were initially adopted. New possibilities and requirements associated with the introduction of a new principle are only gradually recognized. A horse-drawn coach, for example, certainly made no demands on aerodynamics. Such requirements became pressing at much higher speeds which only motorized vehicles could achieve.

The gradual utilization of the potential of a new technological principle depends, however, on economic requirements. The economic pressure and potential fluctuate with time in line with trends in the general economic cycle, for example. These fluctuations can, however, temporarily conceal the longer-term general trends in technological developments in a particular area. These longer-term trends can still be clearly seen, however, in the longer time series in particular. A whole series of technological developments can be explained by studying the connection between various areas of technology [6].

For example, the development of an area of technology may be abruptly interrupted before its potential has been fully utilized. This phenomenon is often associated with the fact that in a rival area methods and resources have been developed that serve the same or a comparable purpose. The decisive factor is the technical and economic efficiency achieved by rival technological solutions or areas. The clear superiority of a technological area or principle can sometimes lead to the disappearance of the rival area. Around the turn of the century, for example, there was intense rivalry between electric and other types of lighting, in particular gas. For a long time this rivalry seemed undecided, before it was finally resolved around 1910. The development of the effective and industrially applicable technology of drawing tungsten wire made it possible to manufacture electric bulbs so efficiently and to give them such performance characteristics that gas-lighting technology was gradually devalued [7].

On the other hand, a positive connection can often be observed between the developments in different areas of technology. It often happens that a long-known technological principle cannot be further developed and applied until developments have taken place in other areas. Such developments will, for example, create technical possibilities that are essential for the application of the technological principle in question. For example, the already known process of vacuum treatment of steel, which led to an improvement of the quality of the steel, could not be applied until the ways and means of economic vacuum production were available at an appropriate level.

In other cases, it is a question of economic opportunities for using a particular process. For example, the idea of using oxygen in the production of steel had already been known for a long time before it was possible to produce oxygen in such quantities and at such cost that this technology could be applied in practice.

Even though in many such cases it is not a question of direct conditions for the continuation of technological work in certain directions, an increase in the scope for applying a technological principle in the general economy has an indirect effect on technological work in this area. The application of a technological principle in the general economy increases the interest in its further development, points to new technical tasks which without application in industry could not be seen at all merely on the basis of experience in the laboratory, and thus contributes to the development of research.

The other hypotheses relate to the general economic conditions for technological development. In the first place, it can be seen time and again that the funds available for research on the innovation process are fluctuating all the time. These fluctuations are linked, for example, to trends in the general economy, but can also be a result of other occurrences, such as natural disasters, wars, revolutions, etc. The funds available to various areas of technology are not all, however, affected to the same extent by such occurrences.

The economic demand for innovations also fluctuates with time. This process too is linked to trends in the general economy and to other occurrences of the type mentioned above, and here again it can be seen that the effect on different areas of technology can and does differ and that these developments and occurrences have an effect on the structure of technological activity.

The fluctuations in economic demand for technology and innovations and the fluctuations in the funds available for innovations and research can be classified hierarchically and subdivided into long, medium and short term.

Examination of trends in the general economy and in technology shows that the *production* of technological know-how, the *demand* for innovations and the *introduction* of new technologies to production do not take place at the same pace. This is typified by differences - both leads and lags - in the time sequence of these processes. As a result, the process for using the inventions in the general economy comes to a temporary halt, or the economic need for new solutions is not particularly great, or again the economy's heavy demand for innovation cannot be met or demand precedes the potential or actual production of technological know-how.

These conflicts and differences also give rise to the driving forces for both inventions and innovations and for the introduction of new ideas to the economy. This can lead to situations of the type described in the literature within the concept of the stalemate in technology (Gerhard Mensch).

Fig. 2.



Fig. 1.

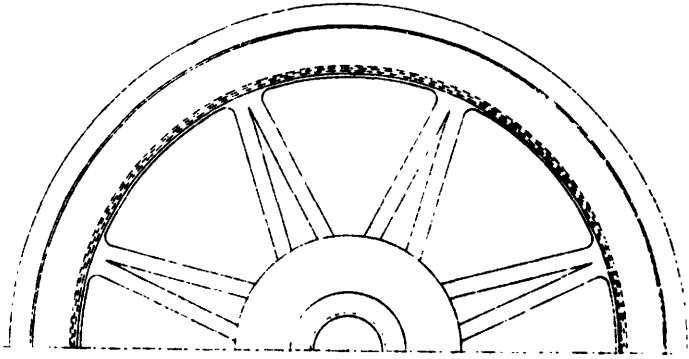

Fig. 5.

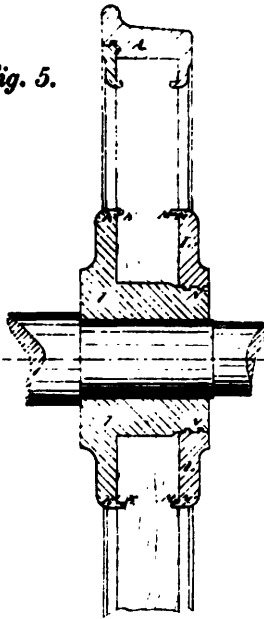

Fig. 4.

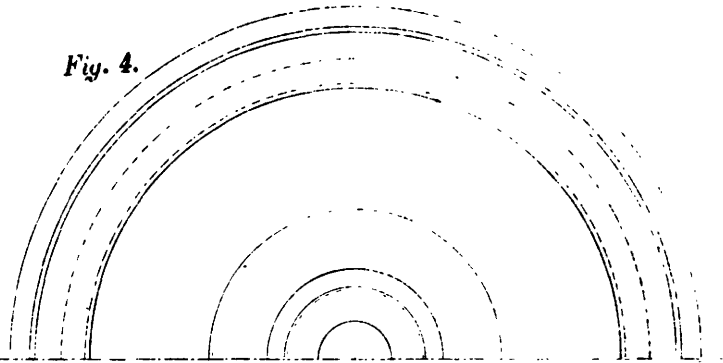
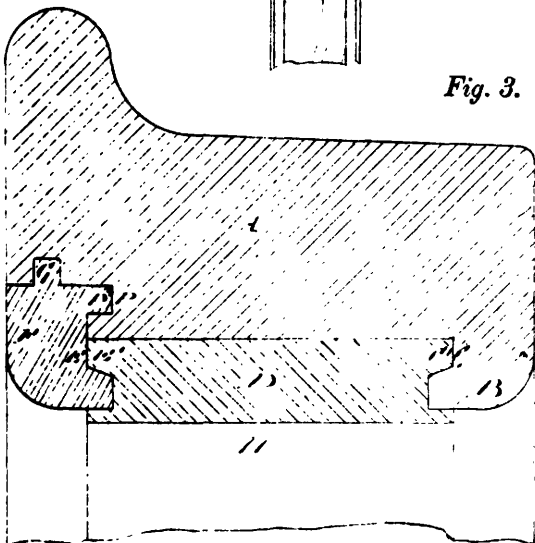

Fig. 6.

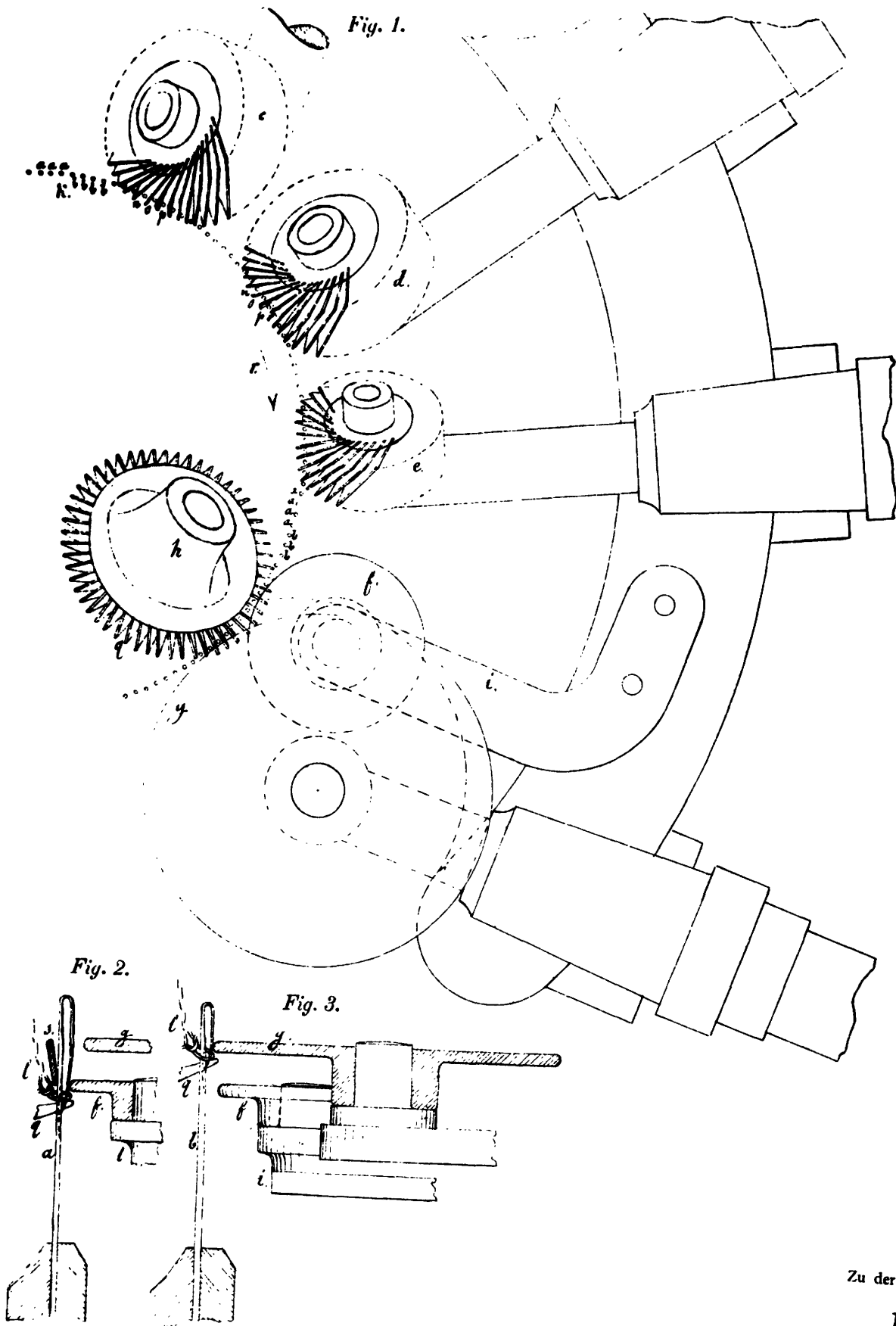

Fig. 3.



HUGO ZWINGENBERGER IN ERNSTTHAL IN SACHSEN.

Einrichtung von Rund-Wirkmaschinen zur Herstellung von Pressmustern.



Zu der Patentsch

№ 3.

PHOTOGR. DRUCK DER KÖNIGL. PREUSS. STAATSDRUCKEREI.

NOTES REFERRING  
TO  
PART II

## NOTES REFERRING

TO

## PART II

[1] A typical example of the overestimation of leaps in development and the underestimation of the continuity of technological development is provided by the theory of G. Mensch. His distinction between basic and improvement innovations is virtually impracticable empirically. In this context, Borchardt puts forward important theses; he speaks of a stream of growth in know-how. Delbeke criticizes Mensch's arguments directly. He shows amongst other things that inventions are not dependent exclusively on demand. Mensch, on the other hand, completely disregards the technical and scientific problems arising on the supply side of the production of technological know-how. The history of science and technology provides countless examples of the difficulties standing in the way of a basic idea and its implementation (see note [6]). Economic pressure and intensive research can certainly have some effect here. Nevertheless, the result remains uncertain and the solution is a long time coming. On the other hand, the goal can often be achieved quickly with modest resources. In the following pages we reproduce Mensch's basic theses in his own words and a number of other relevant comments :

*"The main thesis of this book (stagnation = lack of basic innovations) was conceived and developed at a time (1970-71) when economic research was still projecting incessant economic growth and when science and technology policy were expected to produce the right kind and appropriate volume of new technology to nurture this industrial evolution.*

*At that time, I became aware of some fundamental properties of this evolutionary process of socio-economic change. They indicated that the next downturn of the business cycle would bring disappointment to those who relied on the prognosis of 'just a mild recession'. Among the early indicators of a coming depression were labor market and capital trends as well as indicators of change in the international division of labor and technological change and substitution.*

*In modern industrial civilization, the boundary between nature and culture becomes increasingly fuzzy, and many of the socio-economic forces manifest themselves in the use and creation of artifacts. Therefore, indicators on the rate and direction of industrial innovations can be expected to tell us a good deal about change within a changing economy.*

*The circular flow model of short-term economic activity needs a counterpart; I suggest a metamorphosis model of long-term socio-economic change.*

*The following two propositions characterize the industrial metamorphosis :*

- 1. Basic innovations, which establish new branches of industry, and radical improvement innovations, which rejuvenate existing branches, tend to occur discontinuously in time, namely, in rushes.*
- 2. Within those new or renewed branches, the pioneering innovations are followed by series of improvement innovations. The improvement effects of these successive innovations are governed, on the demand side, by the law of diminishing marginal utility and, on the supply side, by the law of diminishing marginal returns on investment." \*)*

*"In my view, the history of invention all too often still pays tribute to a heroic view of history - and this at a time when political historiography is moving away from the admiring accentuation of the great individuals. However, hero worship in the chronicles of technology is certainly even more doubtful than in other areas of history, since all inventions form part of a stream of growth in know-how, and it is extremely difficult to distinguish certain inventions clearly from other contributions to progress. Anyone familiar with patents knows how difficult it is to assess originality; and yet the hero occupies a central place in the chronicles of technology. His survival in these chronicles has already been discussed 40 years ago by Ralph C. Epstein.*

*The starting point for works on the history of technology is often a biographical interest, and the list of sources naturally refers time and again to individuals as inventors. However, it is certainly too short-sighted to extol the individual alone as the origin of all inspiration. Although it is also acknowledged that the individual owes his ideas to some sort of instinctive necessity and therefore acts only as the executor of immanent technical progress and perhaps also reacts to economic stimuli, the impression is often given that the authors believe that if it had not been for their hero there would not have been certain inventions or whole lines of development. The mere fact that in not a few cases inventions have been made several times or equivalent inventions have solved the same problem strengthens our supposition that a social or*

---

*\*) Mensch in foreword to "Stalemate in Technology - Innovations overcome the Depression", Cambridge (USA), 1979, pp. XVII - XVIII.*



systematic theory of innovation and the spread of inventions hold out more hope of success than a Faustian individualistic theory.

Virtually every part of the steam engine was already known at the beginning of the 18th century, and in the case of the gas and petrol engine it can clearly be seen how the inventors gradually groped for the solution. Major inventions represent the accumulation of many small steps, the final step in a long chain or the transfer of an idea to another field. Jewes, Sawers and Stillermann share the view with many others that 'Technical progress is an indivisible moving stream from which it seems impossible, except in an arbitrary fashion, to isolate one fragment for independent examination'." \*)

"Mensch's analysis is interesting because of its updating and statistical testing of Schumpeter's theory and the emphasis it places on demand and innovation as crucial factors for economic development. But Mensch skirts dangerously close to monocausality and neglects other crucial factors, which we consider in the following sections.

Mensch does remedy a major lacuna of most theories, namely the neglect of demand as the engine for long wave movement. However, we do not agree with the position that expansionary innovations are always more demand-inducing than rationalising innovations because of the different income effects they generate. Rationalising innovations surely can induce a larger demand if the more efficient use of production factors is translated into increased purchasing power and unemployment is neutralized by job creation in other sectors, e.g. the tertiary sector. However, when there is a technological stalemate, we do agree that rationalizing innovations will be less demand-inducing than expansionary ones because of the difficulties in creating alternative employment because of the slowdown of economic growth. In short, Mensch's comparative statics do not always give the same dynamic results.

A major weakness in Mensch's empirical research is the lack of a good criterion for identifying the basic and improvement innovations. Although the difference is crucial, the interpretation of a concrete innovation is difficult and risky. For this reason, it is difficult to integrate into Mensch's theory those innovations that needed two long waves to exert their full effect on economic growth, e.g. automobile construction. Because these sectors have undergone intensive changes, it is uncertain whether they should be classified in terms of basic or of improvement innovations.

An important feature of innovation theory is the emphasis on the discontinuity, the clustering, of basic innovative activity. Periods of scarcity and abundance of entrepreneurial activity seem to alternate in economic development.

---

\*) K. Borchardt, *Technikgeschichte im Lichte der Wirtschaftsgeschichte*, Technikgeschichte Volume 34 (1967) No. 1, pp. 7-8.

But there is a sharp contrast between the Schumpeterian way of treating innovations, and the way macroeconomic and management literature deal with them. In macroeconomics, technological innovation is considered as a continual and even process, so only improvement innovations are dealt with. Such an approach fails to take account of the revolutionary character of basic innovations.

The same idea of continuity is paramount in management literature, but with a more normative character : 'Innovations do not happen, they are made to happen'.

In conclusion, Mensch provides a fruitful analysis of the current situation and implications for the study of the long wave, and the theory's importance is increasing as part of a multicausal explanation." \*)

"Both Mensch and van Duijn have laid great stress on the Schumpeterian idea of the 'clustering' of innovations. In his pioneering work on the *Technological Stalemate*, Mensch argues that basic innovations have been clustered in decades of deep depression, specifically around 1835, 1886 and 1935, and that these basic innovations provide the main impetus for the next big upswing of the economy. During such deep depressions, entrepreneurs are obliged to search for more radical solutions, which were 'crowded out' when business was booming. As the climate is now more favourable to radical innovations, they accelerate their introduction by compressing the lead time from the date of invention to commercial launch. Kleinknecht defends this central idea of Mensch, although with some modifications, in his paper and, clearly, several other contributors (such as Mandel) find the argument persuasive.

I and two colleagues (Clark and Soete), although sympathetic to many aspects of Mensch's work, are not convinced either by theoretical argument or by the empirical evidence so far produced. We have argued elsewhere (in the *Proceedings of the Bochum 1980 conference on long waves*) that the lists of basic innovations compiled in the 1950s or mid-1960s are quite inadequate for the purpose, and we regard the lists used by Mensch as greatly underestimating the basic innovations of the post-war period, and probably also those of 1900-20. By the same token, we are not convinced either by the new list which Kleinknecht has used, derived from Mahdavi. Although this was published in 1972, it was based on a variety of studies from different sectors, some of which were of much earlier date. There is no other possible explanation for the fact that the last major pharmaceutical innovation listed is from 1948. Nor are we convinced by the argument for the separate treatment of scientific instruments, which (partly because Mahdavi's source in this case was more up-to-date) would considerably change the statistical results if grouped either with product or process innovations.

---

\*) J. Delbeke, *Recent Long-wave Theories, A critical survey*, in *Futures*, Volume 13, No. 4, August 1981, pp. 249-250.

We have continued to criticize Mensch's acceleration hypothesis in our own contribution. But we have also attempted to take this debate a stage further, by widening it to include clusters of 'basic inventions' and trends in patents, and to defend the hypothesis (rejected by Mensch) that some clusters of inventions and innovations are more satisfactorily explained in terms of advances in fundamental scientific knowledge.

We have also suggested here (and more fully elsewhere) that, in our view, basic process innovations are most likely to be clustered not so much in depressions as in boom and stagnation periods, when capacity is being expanded rapidly and economies are intensively sought in the new exploding industries, or when costs are under pressure in the older industries. Whilst certainly not rejecting the idea of clustering, we are pleading for a greater recognition of the nature and variety of different 'clusters'". \*)

"Although we do not have systematic comparable annual series for the pre-war period, there is very strong evidence that company outlays for R and D were significantly reduced during the depth of the depression, from 1931 to 1934, in the leading industrial countries. Terleckyj reports a fall of 10 % in US R and D industry over this period. There is now additional evidence that, in the more serious recessions of the 1970s and early 1980s, R and D behaviour may be more affected and may itself have greater effects on other behaviour than in the previous 20 years."

"In an extremely thorough study of long-term trends in patenting in the USA, Schmookler advanced the view that patenting follows closely the fluctuations in fixed investment in plant and machinery in each industry, with essentially the same pattern of upswings and downswings. This has formed the basis for some 'demand-led' theories of innovation which have, however, been heavily criticized by Mowery and Rosenberg and others." \*\*)

[2] "We have drawn, in Figure I (page 78), the total number of patents applied for and granted in the USA from 1840 (year of the Patent Law) to 1979. The diagram suggests that variations in the number of patent applications have tended to coincide with overall economic fluctuations. With an average of a four year time lag - up to the 1960s, the average time needed for the Patent Office to examine and issue a patent was about four years - the evolution of the number of patents granted shows the same kind of behaviour. The steep fall in the early thirties in patent applications coincides most clearly with the 'great depression'. The effects of both the first world war and the second world war are also obvious. Overall, and despite the relatively weaker evidence for the 1875-1884 depression, Figure I tends to support Schmookler's hypothesis. It does not, of course, provide an answer to the question of the possible fluctuations in radical or fundamental inventions.

---

\*) Chr. Freeman, in : *Futures*, Volume 13, No. 4, August 1981, p. 241.

\*\*) J. Clark, Chr. Freeman, L. Soete, *Long Waves, Inventions and Innovations*, in : *Futures*, Vol. 13, No. 4, August 1981, p. 309.

*The advantage of patent statistics is that they provide readily available information over a rather long period which can be easily classified by year, and which is not affected by changes in relative prices. A more important advantage is that they have been collected and examined over all these years by the same official agency, generally speaking a Patent Office. Moreover, all patents issued in the United Kingdom from 1734 onwards have a specification describing the invention in full. It is on the basis of these specifications that an attempt was made by R. Baker of the British Library, to select 'significant' inventions." \*)*

[3] The step function can be brought about by, for example, the revival of old sectors :

*"In 1972 the American national economist and economic and technical historian Nathan Rosenberg put forward in his paper 'Factors Affecting the Diffusion of Technology' the thesis that so-called 'old' technologies believed to be already outdated could be improved again by 'new' trend-setting technologies to such an extent that for a time they would become serious rivals for the 'new' technologies. Although various economists and economic historians had already made similar observations, Rosenberg was the first to bring these together in a single thesis, going against the view predominant in economic theory that it was the competition between rival firms in a particular branch that gave the impetus to technical innovations. He also criticized - quite rightly - the common practice in the chronicles of technology of no longer taking account of the further development of 'old' technologies when the 'new' technologies had been introduced into the production process. Such a view, he stated, encouraged the frequently encountered conception of sudden and dramatic discontinuities in economic and technological development." \*\*)*

[4] Some important comments on this problem :

*"The foregoing brings me to the positive side of our findings. Broadly speaking, our results indicate that inventive activity in a field tends very much to fluctuate with economic activity in that field.*

*Originally it appeared that total inventive activity in the United States varied directly with economy-wide employment of labor and capital combined. This result supported the hypothesis that the potential saving in total cost constituted the source of prospective profit from inventing, that such potential saving would tend to be proportional to total cost of production, and that, therefore, the inventive activity would tend to vary with the total cost, that is, the volume of resources employed. This chain of reasoning later proved mistaken.*

---

\*) J. Clark, Chr. Freeman, L. Soete, *Long Waves, Inventions and Innovations*, in : *Futures*, Vol. 13, No. 4, August 1981, pp. 309-310.

\*\*\*) H.-J. Braun, *Gas oder Elektrizität, Zur Konkurrenz zweier Beleuchtungssysteme, 1880-1914*, in : *Technikgeschichte*, Vol. 47 1980, No. 1, p. 1.

Measures of the two were indeed highly correlated but they were equally correlated with a third variable - gross investment - and this now appears to have been the critical factor.

This error was revealed once the statistics of patents classified by industry were available and patents in the railroad field were compared with an index of total output in the railroad industry. No similarity such as that which had appeared earlier in the case of aggregate inventive activity and total national output emerged. Instead we found that railroad investment and railroad patents were very similar in their long-run and shorter-run movements. The main difference between them, and a very suggestive difference it was, was that the patent statistics lagged slightly behind those of investments." \*)

"This paper examines a question of long standing : How can one obtain operational indexes of inventive and innovative activity and technical change? Specifically, for a sample of fifty seven pharmaceutical manufacturing firms, we attempt to determine how well a simple count of invention patents serves as a surrogate for two alternative measures of technical change : the number of research and development personnel employed, reflecting inputs into the innovative process, and the value of new products sales, which reflects outputs of the process."

"Patent statistics have one compelling advantage over alternative indexes of technical activity : availability in great abundance. Yearly counts are readily obtained for a span of more than a century, either in aggregated form or broken down by class of invention or sponsoring firm. It was this advantage which commended their use in Schmookler's pioneering research, as well as in other studies (Schmookler and Brownlee, 1962; Schmookler and Grilliches, 1963; Scherer, 1965a, 1965b; Grabowski, 1966; and Schmookler, 1966).

Patent statistics, however, have weaknesses acknowledged by users and skeptics alike. For one, the propensity to patent inventions of a given quality has apparently been declining throughout most of this century - and particularly since 1940 - as a result of changes in judicial interpretations of the patent and antitrust laws, the character of industrial innovative activity, the proportion of research and development efforts supported through governments funds, and the Patent Office's budgetary affluence. For this reason, the use of patent statistics for long-run trend analyse is hazardous, although, as Schmookler (1966) has argued, the study of patenting trend deviations can be more fruitful.

Cross-section analyses face other difficulties. The propensity to patent varies from industry to industry and from firm to firm. Industries heavily involved in government contract work tend to patent fewer inventions of a given quality than those which pay for their own research, while firms which are highly patent conscious and maintain a large staff of patent attorneys have a relatively high propensity to patent.

---

\*) J. Schmookler, *Patents, Invention and Economic Change*, Cambridge, Mass. 1972, pp. 74-75.

More important, the quality of the underlying inventions varies enormously from patent to patent. Picking at random a copy of the Official Patent Gazette (for example, for July 25, 1967), one can find patents for inventions ranging from a form-fitting church-pew cushion to a complete system for training a computer to recognize patterns through adaptive response.

Nevertheless, the inability of patent data to reflect inventive 'quality' is not necessarily fatal for it may be possible to measure and roughly correct for interindustry differences in the propensity to patent (see Scherer, 1965b pp. 1098 - 1103). The underlying economic or technological significance can be interpreted as a random variable with some probability distribution, which can be manipulated statistically like any other errorprone measure. Indeed, the quality variability problems in patent data are not fundamentally different from those encountered in using a simple count of scientist or engineers, or research and development expenditures, as an index of innovative input. Creative ability varies greatly from individual to individual, and the market for creative talent is shot through with so many imperfections that attempts to adjust for differences in employee productivity by applying salary weights yield, at best, a modest improvement." \*)

"To a certain extent, the diffusion of technical innovations can be seen from figures of new patents. Whereas in the period from 1715 - 1760, 7 to 8 patents a year on average were granted in England, the number rose to 57 a year by 1790. In the USA, the first Patent Laws were passed in 1787 and 1790 and this was followed by new patent regulations in 1861. Between 1796 and 1826, 5,215 patents were granted in the USA; there is a close connection here with the first 'economic miracle' of modern history. On the other hand, in Prussia, where patenting regulations had not been introduced until 1815, the total number of patents up to 1837 was only 335. In my opinion, this clearly reflects the connection between invention, technology and the economy." \*\*)

According to Kronz, the informative value of the number of patent applications must be considered separately in international comparisons and in the time series :

"... as a more or less usable quantitative indicator I use the patents statistics. The trend in the numbers of applications in the various countries must, even though it is also influenced by the specific features of each country's patent law, reflect the 'conditions and occurrences' of which Sombart has spoken in connection with the different phases of culture.

---

\*) W.S. Comanor, F.M. Scherer, *Patent Statistics as a Measure of Technical Change*, in : *Journal of Political Economy*, Vol. 77, 1969, pp. 392 - 398.

\*\*\*) A. Timm, *Geschichte der Technik und Technologie - Grundsätzliches vom Standort des Historikers*, *Technikgeschichte*, Vol. 35, 1968 No. 1, p. 9.

A random glance at the trends in the numbers of applications shows particularly clearly that the level of applications varies, in some cases considerably, from country to country. These variations in level are a direct expression of the extent to which the 'conditions and occurrences' are peculiar to each country. This view of things must, of course, focus on the proportion of patent applications filed by nationals, since in addition to the competitive interests it reflects primarily the patenting interests of resident inventors and innovators. It thus also says something about national inventive creativity, and this - expressed as the productivity of the population in terms of the production of patent applications - is influenced among other things by the socio-cultural factor, which essentially expresses the attitude of the individual and society to nature and technology." \*)

[5] This trend can be represented by the logistic curve (S-shaped curve).

"Over three decades ago Professor Kuznets published the classic analysis of the Law of Industrial Growth - the tendency for the output of any given good to describe an S-shaped course over time, with the percentage rate of growth generally declining throughout (SIMON KUZNETS *Secular Movements in Production and Prices* [Boston and New York : Houghton Mifflin, 1930]). The pattern, he concluded, was primarily a reflection of retardation in the rate of technical progress in the industry revealed by the downward sweep at a declining rate of the product's price over time. The retardation in the rate of the technical progress in turn was explained by the gradual exhaustion of the industry's inventive potential, or stating the matter in other terms, the approach to perfection of the industry's technique." \*\*)

"The perception of the economic life of a basic or major innovation as an innovation life cycle is not a novel one. I used it in earlier publications, but as it turns out, it was developed earlier by Kuznets, and even, in a rudimentary form, by Schmookler. The life cycle of a major invention indicates how an innovation develops over time, measured as the output accounted for by that innovation.

Life cycles are usually assumed to be S-shaped, up to their decline phase, with gradually decreasing growth rates of output.

While various interpretations and applications of the S-shaped growth curve exist, they can be reduced to two main types : the limited

---

\*) H. Kronz, *Der Soziokulturelle Faktor für die Erfindungs- und Innovationstätigkeit in den Industrie- und Entwicklungsländern*, in : *Mitteilungen der deutschen Patentanwälte*, Vol. 69, January 1978, No. 1, p. 1.

\*\*) J. Schmookler, *Technological Change and the Law of Industrial Growth*, in : *J. Schmookler, Patents, Invention and Economic Change*, Cambridge, Mass., 1972, pp. 77 - 78.

possibilities for further technical improvements given a certain state of technology, versus the limited possibilities for further market penetration given a certain rate of penetration. Both interpretations can be applicable to an innovation life cycle. Usually the two aspects will be interrelated : cost-reducing improvement innovations can increase the rate of penetration of a product; market saturation will be a strong incentive for product improvements, such that a decline in sales can be prevented or postponed. The strongest force, however, would seem to be the market." \*)

"It would appear that for any industrial revolution, there must be a simultaneous appearance of convergent innovations - in energy sources, transport, tools (or the production goods industries) and in 'manufacture'. Hence, an industrial revolution can be defined by this combination of activities and by the prolonged process of expansion which it produces, each new product following a logistic curve. This curve is not so much the 'life cycle' of the new product - a microeconomic notion - as a curve of saturation of the milieu : the new 'population' develops until it has taken up all the terrain open to it. A change of milieu or a change of product can give rise to a new logistic curve. This was the case with steel - in ingots with the first revolution, in sheets with the second. Will it find a new lease of life with the third?"

"The present period - 1975 - 1985 - in this explanation will feature the combination of two movements : the maturity and decline of the major industries of the last industrial revolution; the very weak growth of new activities of the industrial revolution now beginning and which is only in its embryonic phase. The aggregate effect of these two processes gives rise to very slow overall growth." \*\*)

[6] "Modern steel production is unthinkable without vacuum treatment of steels. What does this involve?"

During its production, every type of steel comes in molten form into contact with gases, in particular hydrogen, oxygen and nitrogen, and inevitably absorbs detectable quantities of them. These gases come from the ambient air, the fuel required for the melting process and the moisture content of the raw materials used.

When the melt has been prepared, the steel is poured into moulds in which it solidifies.

As a result of the cooling associated with solidification, the steel's solvent capacity for gases is reduced. Only part of the excess gas released can escape from the steel, which is becoming pasty. The remainder forms gas bubbles, which are enclosed between the already solidified rim and the still molten core.

---

\*) J.J. van Duijn, *Fluctuations in Innovations over Time*, in : *Futures*, Vol. 13, No. 4, August 1981, p. 265.

\*\*\*) A. Piatier, *Innovation, Information and Long-Term Growth*, in : *Futures*, October 1981, p. 375.



During the subsequent processes such as rolling or forging, it is very difficult or even impossible to remove these enclosed gas bubbles. They lead to defects in the steel and reduce its quality.

Metallurgists, who from the very beginning have been striving to improve the quality of their products, have for many years been endeavouring to eliminate this problem, e.g. the Swedish inventor, Dr. H. Tholander, at the end of the 19th century. Tholander knew about the gas bubbles enclosed in the steel ingots and, as we know today, had the right idea about how to get rid of them. In German patent 16479 granted in 1881, he proposed to eliminate the gases from the molten steel contained in a converter or pouring ladle by reducing the pressure. This proposal was based on the knowledge that, as in the case of other fluids, the gases released at a higher pressure escape from the molten steel when the air begins to get thinner.

This technical theory did not, however, gain acceptance. The requisite technology was not yet available because the efficient vacuum pumps required did not exist in 1881. This was ultimately the cause of the failure of all the attempts made in later decades up to 1950 to use vacuum treatment of steels on an industrial scale." \*)

In this context, Borchardt speaks of invention chains.

"For example, for certain inventions dozens of follow-up and supplementary inventions have in many cases become necessary in order to make the basic idea at all usable. The steam engine is one of the best known examples of this. Watt's achievement is precisely that by means of additional measures he made a known piece of equipment economically usable on a large scale for the first time. However, his success was in turn dependent on the fact that at more or less the same time the technique of metal working, and in particular cylinder boring, were considerably improved. We economic historians would be grateful for detailed descriptions of the technical problems of invention chains of this type, so that we do not run the risk of overlooking that which is obvious to the engineer as a result of our socio-cultural speculations." \*\*)

[7] "To sum up : after a phase of the predominance of oil and gas lighting which lasted into the 1880s, electric lighting spread quickly after the development of the Edison bulb and in view of various advantages was frequently regarded as the lighting system of the future. However, the 'old' type of lighting, namely gas, which had come under pressure, was able to check the progress of electric lighting thanks to Auer's incandescent gas light and expanded rapidly.

---

\*) H.D. Klemm, *Die Entwicklung der Vakuumbehandlung der Stähle,, in Hundert Jahre Patentamt, Munich, 1977, pp. 161 - 162.*

\*\*\*) K. Borchardt, op. cit., pp. 6 - 7.

*It was Auer in particular, but also Werner von Bolton, who on the highly concentrated market for electric bulbs gave the edge to the electrical industry though pioneering developments of the metal filament lamp. Although the gas industry was able to make up ground again in the field of public lighting through the compressed-gas lamp, the development of luminous arc lamps gave the electrical industry the edge here as well.*

*As regards my initial hypothesis, which was derived from Rosenberg's thesis on the relationship of 'old' to 'new' technologies, the following should be noted : the thesis is confirmed as far as the relationship of the electric arc light and incandescent light to Auer's incandescent gas mantle is concerned. In this case, the example quoted here seems even more appropriate than the one given by Rosenberg himself. The same applies to the advent of the compressed gas lamp in relation to the traditional arc lamp.*

*However, to qualify the above remarks it should also be noted that in addition to the improved 'old' technology - represented in this example by the incandescent gas mantle - there were other important aspects, such as the cheaper coke-oven gas, the increase of sales of gas through price differentiation and, albeit not so significant, the competition between different gasworks.*

*In addition to purely economic and technological aspects, mention must be made of political ones, such as the effects of the illuminant tax of October 1909. In addition, general economic interests aimed at safeguarding existing assets were involved in advocating retention of the 'old' technology. These were endorsed by representatives of many municipalities, who feared that, as owners of gas works, they would suffer financial losses after the introduction of electric lighting.*

*The main factor behind the development of Auer's osmium lamp was not the competition for a rival technology based on a different system but the competition within a particular sector, namely the electrical industry. On a highly concentrated market a specialist firm succeeded in introducing a development that was crucial for the future of electric lighting." \*)*

O'Dea also writes about the same process :

*"By the time the filament lamp had become of undeniable significance the advent of the incandescent mantle burner for gas lamps had restored the balance between electricity and gas.*

*It was about 1890 that the gas mantle began to forge ahead and it soon caught up with and outtripped the electric lamp competitor. The gas mains and distribution pipes were not only already there, but gas cookers and gas fires were cheaper to run than their electrical counterparts. There was much more incentive to convert Sugg burners to gas mantles than to undertake the great expense of laying on an electric supply for filament lamps that were neither efficient nor long-lasting by modern standards.*

---

\*) Braun, op. cit., pp. 14 - 15.

*It was, in fact, not until about 1913 that the filament lamp began to show advantages so demonstrable that in many cases the installation of the necessary wiring was amply worth while. The rest of the story is a question, largely, of reductions in the price of electricity and the price of electric lamps. Gas lighting was admirable in many ways and devices were invented to make the control of it at least comparable with the troublefree control of electric lights. Nevertheless it had disadvantages domestically, such as the dirtying of ceilings and excessive heating from which electric lamps did not suffer, and for public installations it was obvious that only by rearguard action could it maintain any sort of hold. Just as Edison's lamps infiltrated into a field ostensibly more economically served by gas, so in Britain there have recently been artificial adjustments of the economy of the electric-power prices as between town and country that have theoretically restored the economic position of gas in some cases. In spite of that there is not flight from electricity for lighting and this in itself is sufficient indication that the public have selected electric lighting on merit." \*)*

---

\*) W.T. O'Dea, *The Social History of Lighting*, London, 1958, p. 25.

STEPHAN, DR. MED., PRAKT. ARZT IN ILSENBURG.

**Gebärmutterhalter.**

*Fig. 1.*

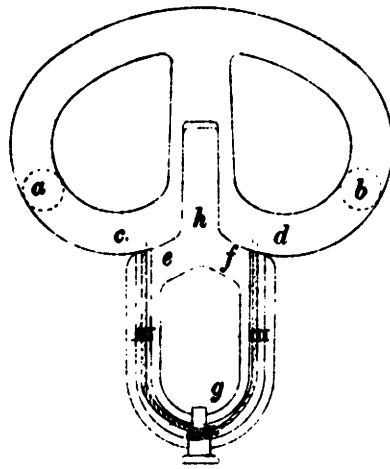

*Fig. 2.*

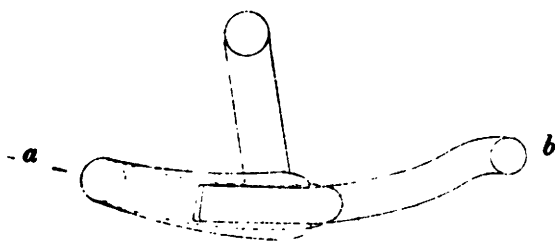

*Fig. 3.*

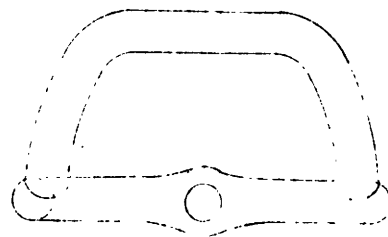

Zu der Patentschrift

**№ 29.**

ALBERT KOHM IN KARLSRUHE.

Verbesserungen an dem Esmarch'schen Irrigator.

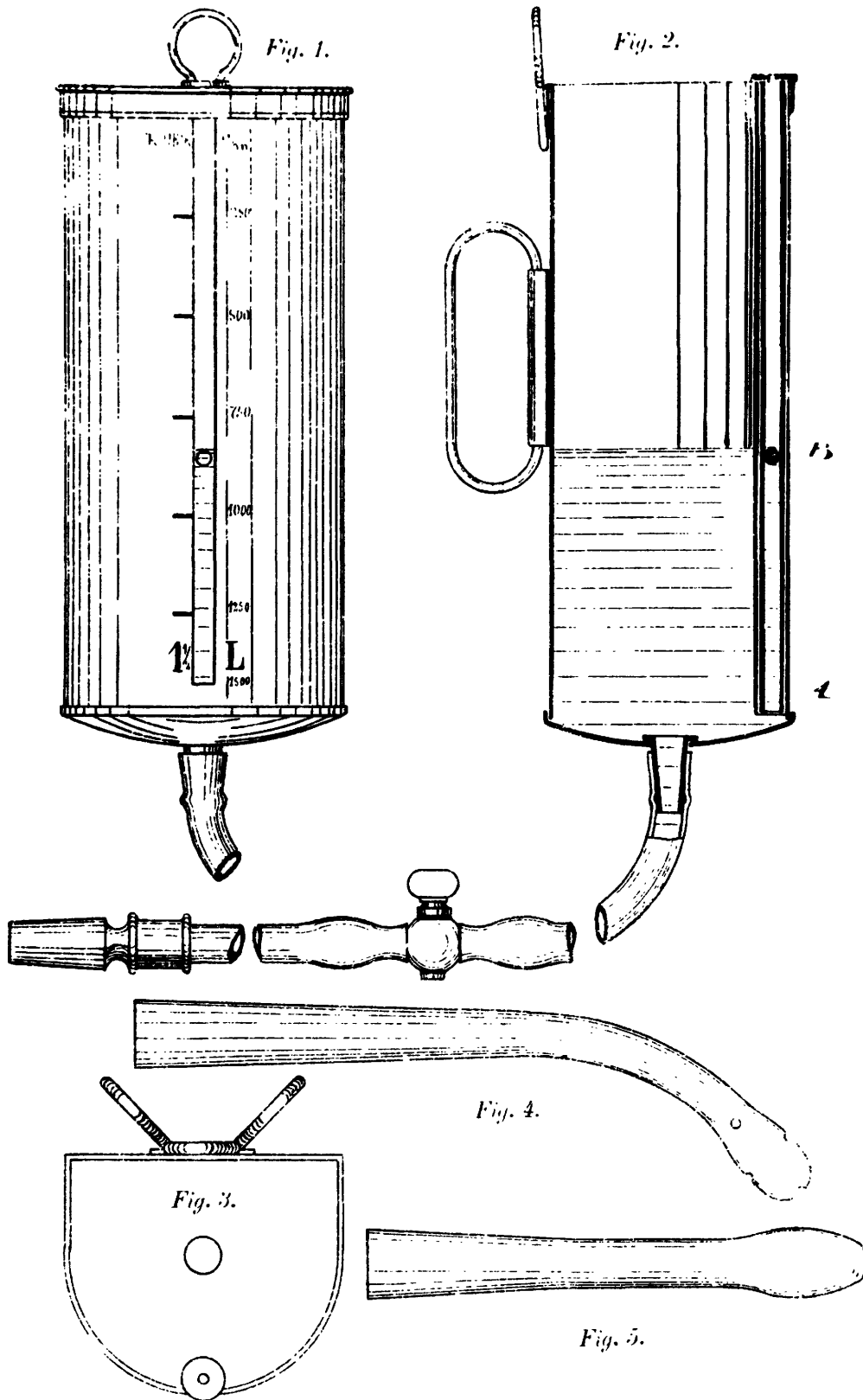

Zu der Patent

PHOTOGR. DRUCK DER KÖNIGL. PREUSS. STAATSDRUCKEREI.

№ 36

PART III



## Part III

### STATISTICAL ANALYSIS AND INTERPRETATION OF TRENDS IN PATENT APPLICATIONS

In the main part of this study, all the 89 time series of patent applications in Germany are statistically analysed and interpreted. For this purpose, the estimates of the logistic function and of the growth trends are used in conjunction with a linear spline function of the time trend. Lastly, an attempt is made to differentiate in statistical terms between various influences on the trends in patent applications. The hypotheses mentioned earlier are empirically tested in these analyses.

#### *A. Analysis and Interpretation of Trends in Patent Applications on the Basis of the Logistic Functions*

The logistic function is a highly appropriate way of describing the growth processes which with initially increasing and subsequently decreasing absolute growth rates are nearing an upper limit. Such processes are very widespread both in nature and society. The upper limit of the logistic function can often be determined substantively, i.e. in economic, technical, biological and other terms.

In the analysis of patent applications, the upper limit of the logistic function can also be described as a quantitative expression of the state of exhaustion of the innovative potential of the particular areas of technology. The other parameters of the logistic function can be identified as the rate of this trend and as the quantitative expression of the age of each area of technology.



The use of the logistic function to describe and analyse trends in patent applications has the following advantages : the statistical estimate of the logistic function makes it possible to identify the long-term trends in each patent class and to correct them for short- and medium-term fluctuations.

This estimate also makes it possible to concentrate the available data. The main tendencies to emerge from the almost 100 annual observations of trends in patent applications have been shown in condensed form on the basis of the three afore-mentioned parameters of the logistic function.

The concentration of the whole on the information of a few parameters of the individual patent classes facilitates comparison between these classes. Using three parameters, it is possible to determine a time sequence of patent classes and thus of individual areas of technology. According to our assumptions, individual areas of technology evolve in a sequence corresponding to their development and exhaustion.

It is not by chance that the logistic function is suitable for analysing the time series of patent applications. It represents recurring changes in individual areas of research and innovation. Every research sector is in the long term under pressure from the needs of the economy and society. In most cases, these are the production and sales needs of corresponding production branches. Research is intended to improve the quality, increase the volume and bring down the price of production. In order to fulfil these tasks, research gradually exhausts the potential of the particular area of technology. This process is reflected both in the number and in the quality of inventions and the corresponding patent applications.

As regards the exhaustion of the technical potential of the area, the following trends are assumed :

1. The research sector is initially on the upgrade. The annual number of inventions and patent applications increases. Once the peak has been reached, the annual number of patent applications begins to fall.
2. The quality and economic and technical importance of inventions show a similar trend. The nearer research comes to the sector's limits, the smaller the economic and technical importance of any further inventions.
3. The widespread exhaustion of the technical potential of the area is probably also reflected in the increase in the number of unsuccessful patent applications.

The long-term tendencies, which affect the trend in patent applications in individual areas, are reflected in the development of the time series. They are modified, but not cancelled out, by medium- and short-term fluctuations, which are linked to trends in the economic cycle, wars and natural disasters, political developments and also lucky strikes by research workers. These fluctuations reflect changes in consumer demand, the pressure of competition, the allocation of funds for research, the work of the education system and other factors.

The results of the estimate of the logistic function for each of the patent classes are set out in Tables 1 - 3.

Table 1 shows the estimated results for the period 1886 - 1973. The estimate was successful for almost all the patent classes, the only exception being Class 62 'Aviation', for which the logistic function cannot be used owing to special developments.

The table shows first of all the afore-mentioned parameters a, b and c of the logistic function.

Parameter a can be described as the quantitative expression of the age of the relevant patent class. The smaller this parameter is, the further in the past are the beginnings of technology in this class.

Parameter b of the logistic function describes the rate of development in the relevant patent class.

Parameter c is the parameter of the upper limit to which the logistic function is tending asymptotically. This parameter can be characterized directly as the cumulative number of annual patent applications in the class when the upper limit was reached.

To illustrate the results of the estimate of the logistic function, a number of other estimated values are given. First of all, the results of the estimate are expressed in terms of time. A rough idea of the age of individual patent classes, which could also be described with parameter a, makes it possible to determine the year in which the estimated logistic function reaches 10 % of the upper limit. The year in which half of the upper limit was reached identifies the peak of the trend in each class. This year is the one with the greatest annual number of patent applications.

By giving the estimated value of the function for 1981, it is possible to determine the order of the patent classes with regard to the exhaustion of innovative potential. This number of patent applications was then calculated as a percentage in relation to the upper limit.

For some of the patent classes it was possible to calculate the data beyond 1973 as well. These are the classes which show a relatively easily ascertainable correspondence between the old German classification and the new international classification (see Table 2).

In Table 3 an attempt was made to compare the results in Germany with those in the USA. It proved possible to identify both simultaneous developments and leads and lags in corresponding patent classes in the USA and Germany.

Table 1

Trends in German patent applications in the period 1886-1973 on the basis of the logistic function (standard error in brackets)

Patent class	Coefficients of the logistic function			Estimated year in which reached	Estimated value for 1981	7/4 in %		
	a	b	c					
	$P = \frac{c}{1+ae^{-bt}}$			1/10c	1/2c			
	1	2	3	4	5	6	7	8
1. Preparation of ores	75.5 (2.7)	.075 (.0009)	9050 (73)	1904	1934	8530	94.3	
2. Baking	67.6 (3.5)	.081 (.0013)	12457 (100)	1901	1928	12070	96.9	
3. Wearing apparel	46.2 (1.7)	.077 (.0099)	34198 (215)	1898	1926	33209	97.1	
4. Lighting through fuels and preheating torches	36.5 (2.2)	.084 (.0017)	34811 (262)	1893	1919	34343	98.7	
5. Mining	120.0 (5.5)	.069 (.0012)	38157 (793)	1914	1957	32124	84.2	
6. Zymology	10.7 (.5)	.054 (.0019)	14567 (271)	1880	1919	13733	94.3	
7. Mechanical metal working (1900-1973)	104.3 (8.1)	.073 (.0019)	40534 (934)	1910	1951	36405	89.8	
8. Bleaching	44.5 (1.8)	.059 (.0013)	77135 (1762)	1904	1952	65432	84.8	
9. Brushware	114.0 (5.0)	.093 (.0010)	10257 (51)	1904	1928	10057	98.1	
10. Fuels	136.7 (7.8)	.100 (.0013)	14802 (78)	1903	1926	14620	98.8	
11. Bookbinding	54.4 (1.3)	.070 (.006)	20374 (132)	1902	1934	18919	92.9	
12. Chemical processes	147.1 (5.8)	.059 (.0014)	356619 (21347)	1924	1972	227012	63.7	
13. Steam boilers	24.8 (1.0)	.073 (.0012)	26316 (188)	1890	1920	25649	97.5	
14. Machines or engines in general (1886-1938)	44.5 (4.0)	.101 (.0033)	20152 (363)	1892	1914	20088	99.7	
14. Machines or engines in general (1886-1973)	30.1 (3.0)	.082 (.0028)	23235 (297)	1891	1918	22918	98.6	
15. Printing	55.5 (3.0)	.075 (.0014)	51942 (568)	1901	1930	49467	96.5	
16. Manufacture of fertilizers	100.1 (5.3)	.084 (.0012)	6373 (51)	1905	1931	6149	96.5	
17. Refrigerat.or cooling, stor.of ice,heat transf.	113.2 (5.1)	.072 (.0011)	31163 (464)	1912	1953	27361	87.8	
18. Metallurgy of iron	157.2 (4.7)	.077 (.007)	30100 (252)	1914	1953	26995	89.7	
19. Construction of roads, railways and bridges	40.4 (1.6)	.060 (.0012)	32098 (569)	1901	1938	27990	87.2	
20. Railway transport	39.2 (2.0)	.078 (.0014)	73385 (575)	1895	1923	71485	97.4	
21. Electrical engineering	209.2 (11.5)	.079 (.0013)	523169 (7758)	1916	1955	467294	89.3	
22. Dyes, paints, etc.	27.4 (1.0)	.052 (.0013)	54363 (1488)	1898	1951	45102	83.0	

Table 1 (continued)

Patent class	Coefficients of the logistic function			Estimated year in which reached	Estimated value for 1981	7/4 in %		
	a	b	c					
	$P = \frac{c}{1+ae^{-bt}}$							
				1/10c	1/2c			
	1	2	3	4	5	6	7	8
23. Oils and fats	72.9 (2.5)	.068 (.0009)	25168 (299)	1907	1951	22442	89.1	
24. Furnaces etc.	64.6 (2.6)	.082 (.0010)	44344 (266)	1901	1928	43073	97.1	
25. Braiding, lace-making, etc.	38.2 (1.3)	.060 (.0011)	21689 (355)	1901	1937	19054	87.9	
26. Production of gases	14.2 (1.5)	.076 (.0034)	14530 (202)	1883	1911	14360	98.8	
27. Fans, air pumps and compressors	38.6 (1.0)	.055 (.0009)	17152 (313)	1903	1954	14094	82.2	
28. Tanning	57.9 (1.5)	.084 (.0007)	7256 (26)	1899	1925	7107	97.9	
29. Yarns	185.7 (15.0)	.083 (.0018)	16131 (259)	1913	1950	15016	93.1	
30. Medical science	86.6 (3.8)	.077 (.0011)	83959 (765)	1906	1934	79010	94.1	
31. Casting, powder metallurgy	81.4 (4.2)	.056 (.0019)	35614 (2236)	1916	1966	25099	70.5	
32. Glass	48.1 (1.4)	.051 (.0012)	21856 (843)	1909	1963	15720	71.9	
33. Hand and travelling articles	49.9 (1.7)	.074 (.0009)	27473 (190)	1900	1929	26227	95.5	
34. Furniture	38.6 (1.2)	.066 (.0009)	120202 (1147)	1899	1932	111195	92.5	
35. Lifting gear	54.9 (3.4)	.066 (.0017)	32033 (687)	1904	1937	28778	89.9	
36. Heating	41.2 (1.0)	.065 (.0007)	45668 (346)	1900	1934	41678	91.3	
37. Building	54.1 (2.3)	.055 (.0015)	118705 (4697)	1909	1959	90487	76.2	
38. Wood working	35.0 (1.1)	.065 (.0009)	28821 (280)	1898	1932	26663	92.5	
39. Working of plastic masses etc.	1883.9 (80.7)	.078 (.0014)	288013 (26966)	1956	1983	133672	46.4	
40. Metallurgy other than of iron	68.4 (2.1)	.063 (.0009)	27330 (459)	1909	1955	22937	83.9	
41. Headwear	28.3 (.8)	.071 (.0008)	3418 (19)	1893	1923	3303	96.6	
42. Instruments	91.1 (3.2)	.061 (.0011)	254113 (6873)	1914	1962	193229	76.0	
43. Checking devices (1900-1973)	98.4 (8.5)	.074 (.0021)	27184 (594)	1909	1938	24862	91.5	
44. Haberdashery, jewellery, etc.	40.6 (1.9)	.078 (.0013)	29480 (220)	1896	1923	28733	97.5	
45. Agriculture	53.8 (2.0)	.072 (.0010)	107986 (940)	1901	1932	101343	93.8	

Table 1 (continued)

Patent class	Coefficients of the logistic function			Estimated year in which reached	Estimated value for 1981	7/4 in %		
	a	b	c					
	$P = \frac{c}{1+ae^{-bt}}$							
	1	2	3	4	5	6	7	8
46. Combustion engines	143.6 (7.4)	.091 (.0012)	98467 (629)	1907	1931	95782	97.3	
47. Engineering elements or units	59.8 (2.3)	.055 (.0013)	217476 (8191)	1911	1961	163300	75.1	
48. Work.&treatm.of metals other than by mech.means	188.9 (3.3)	.062 (.0006)	37150 (876)	1925	1972	24119	64.9	
49. Machine tools	34.1 (1.0)	.056 (.0010)	88784 (1566)	1900	1950	74928	84.4	
50. Grinding and pulverizing	25.2 (.4)	.049 (.0006)	30155 (473)	1897	1953	24162	80.1	
51. Musical instruments	16.4 (.6)	.069 (.0011)	15696 (102)	1885	1917	15318	97.6	
52. Sewing and embroidering	23.2 (.4)	.060 (.0006)	19022 (120)	1892	1925	17662	92.6	
53. Foodstuffs	57.7 (2.5)	.076 (.0011)	34494 (287)	1901	1930	33032	95.8	
54. Working of paper and board	118.8 (7.4)	.091 (.0015)	38515 (282)	1905	1929	37685	97.8	
55. Production of cellulose, paper and board	43.7 (1.3)	.065 (.0008)	21442 (213)	1901	1935	19556	91.2	
56. Upholstery and saddlery	16.9 (1.3)	.071 (.0024)	3239 (43)	1885	1915	3174	98.0	
57. Photography, cinematography and sound film	160.1 (13.6)	.078 (.0020)	71529 (1532)	1913	1953	64355	90.0	
58. Presses	27.2 (1.2)	.040 (.0012)	11438 (784)	1904	1970	6995	61.2	
59. Pumps	34.7 (.8)	.050 (.0009)	30014 (781)	1903	1958	22849	76.1	
60. Hydraulics and pneumatics (up to 1938)	24.2 (1.3)	.096 (.0022)	2128 (23)	1887	1910	2122	99.7	
61. Life-saving and fire-fighting	72.1 (5.9)	.075 (.0020)	12317 (219)	1904	1933	11601	94.2	
62. Aviation	Estimation failed							
63. Trackless vehicles	93.4 (4.5)	.078 (.0012)	186562 (1772)	1906	1934	176283	94.5	
64. Distribution of alcoholic liquors	23.4 (1.0)	.064 (.0013)	39365 (449)	1891	1924	37392	95.0	
65. Ships	57.5 (4.3)	.083 (.0019)	32750 (345)	1899	1926	31965	97.6	
66. Butchering and meat treatment	67.0 (4.0)	.074 (.0015)	7691 (102)	1904	1933	7236	94.1	
67. Grinding and polishing	101.9 (4.8)	.078 (.0011)	20069 (197)	1908	1936	18836	93.9	
68. Articles of the locksmithing trade	40.5 (2.6)	0.74 (.0017)	41119 (510)	1897	1927	39533	96.2	
69. Cutting tools	47.9 (2.0)	.071 (.0011)	10142 (98)	1900	1931	9580	94.5	
70. Writing and drawing implements	37.8 (1.0)	.073 (.0007)	24949 (135)	1896	1926	23965	96.1	

Table 1 (continued)

Patent class	Coefficients of the logistic function			Estimated year in which reached		Estimated value for 1981	7/4 in %
	a	b	c	1/10c	1/2c		
1	2	3	4	5	6	7	8
71. Footwear	80.5 (2.7)	.090 (.0008)	29623 (114)	1901	1925	29131	98.3
72. Firearms	51.1 (4.8)	.085 (.0024)	33847 (395)	1897	1923	33270	98.3
73. Ropes	34.9 (1.0)	.051 (.0011)	2148 (63)	1903	1957	1678	78.1
74. Signalling	128.2 (6.4)	.093 (.0012)	27829 (156)	1905	1929	27267	98.0
75. Sculpture, painting, etc.	63.6 (3.4)	.063 (.0015)	24961 (613)	1907	1953	21454	86.0
76. Spinning	36.0 (.7)	.051 (.0007)	34028 (712)	1904	1958	25946	76.2
77. Sports, games and amusements	78.6 (8.8)	.094 (.0028)	57306 (641)	1900	1923	56647	98.9
78. Explosives	37.2 (2.3)	.077 (.0017)	9270 (92)	1895	1923	9035	97.5
79. Tobacco	52.3 (2.4)	.066 (.0013)	11821 (186)	1903	1936	10690	90.4
80. Clay articles etc.	42.6 (1.7)	.062 (.0012)	61963 (1038)	1902	1937	54938	88.7
81. Transport and packing	160.1 (7.5)	.066 (.0014)	122827 (4000)	1920	1964	92259	75.1
82. Drying	38.3 (1.4)	.060 (.0011)	18894 (300)	1900	1937	16710	88.4
83. Measurement of time	33.2 (.8)	.053 (.0009)	18326 (358)	1901	1954	14931	81.5
84. Hydraulic engineering and foundations	111.4 (5.7)	.065 (.0015)	20128 (599)	1915	1960	16163	80.3
85. Water purification etc.	23.3 (.9)	.052 (.0014)	33345 (889)	1895	1938	28188	84.5
86. Weaving	19.7 (.7)	.054 (.0012)	23382 (410)	1891	1931	20930	89.5
87. Tools and implements	53.4 (3.2)	.071 (.0016)	15687 (225)	1902	1932	14701	93.7
88. Machines (excluding classes 46, 14)	70.5 (4.6)	.091 (.0017)	10437 (74)	1899	1923	10301	98.7
89. Sugar and starch industry	7.1 (.2)	.052 (.0013)	8288 (98)	1873	1914	7869	94.9

Table 2

Trends in German patent applications in the period 1886-1980 on the basis of the logistic function (standard error in brackets)

Patent class	Coefficients of the logistic function			Estimated year in which reached		Estimated value for 1981	7/4 in %
	a	b	c	1/10c	1/2c		
	1	2	3	4	5	6	8
3. Wearing apparel	46.3 (1.6)	.077 (.0008)	34161 (153)	1898	1926	33104	96.9
5. Mining	118.7 (5.0)	.068 (.0010)	38385 (485)	1914	1957	32195	83.9
7. Mechanical metal working (1900-1980)	88.4 (6.6)	.066 (.0017)	46198 (1020)	1911	1956	38962	84.3
9. Brushware	107.4 (4.6)	.090 (.0010)	10402 (42)	1904	1928	10175	97.8
14. Machines or engines in general	20.5 (2.5)	.063 (.0035)	27295 (714)	1890	1924	25877	94.8
16. Manufacture of fertilizers	92.8 (4.7)	.082 (.0011)	6526 (41)	1905	1933	6258	95.9
18. Metallurgy of iron	162.2 (4.6)	.078 (.0006)	29577 (150)	1914	1953	26717	30.3
19. Construction of roads, railways and bridges	39.1 (1.4)	.058 (.0010)	34197 (493)	1902	1951	29123	85.2
22. Dyes, paints, etc.	27.7 (.9)	.048 (.0012)	62304 (1669)	1900	1957	47646	76.5
32. Glass	50.0 (1.3)	.049 (.0009)	24572 (749)	1912	1968	16314	66.4
34. Furniture	37.0 (1.2)	.063 (.0008)	124859 (1017)	1899	1934	113806	91.1
35. Lifting gear	51.6 (2.9)	.062 (.0014)	34659 (621)	1905	1951	30049	86.7
37. Building	54.4 (2.1)	.054 (.0012)	124909 (3338)	1910	1961	93546	74.9
40. Metallurgy other than of iron	66.5 (2.0)	.060 (.0008)	29165 (379)	1910	1957	23646	81.1
41. Headwear	27.1 (.8)	.069 (.0008)	3495 (18)	1892	1924	3358	96.1
44. Haberdashery, jewellery, etc.	37.7 (1.8)	.075 (.0012)	30306 (203)	1896	1925	29358	96.9
45. Agriculture	50.0 (2.0)	.069 (.0010)	112891 (916)	1901	1950	104794	92.8
46. Combustion engines	118.4 (8.0)	.085 (.0015)	103841 (808)	1908	1933	99774	96.1
47. Engineering elements or units	60.5 (2.1)	.053 (.0010)	235439 (6252)	1912	1964	168056	71.4
48. Work. & treatm. of metals other than by mech. means	194.0 (7.1)	.067 (.0009)	30937 (529)	1922	1966	22718	73.4
49. Machine tools	33.5 (1.0)	.053 (.0009)	95906 (1470)	1901	1953	78278	81.6
58. Presses	41.4 (3.6)	.035 (.0011)	19815 (2330)	1920	1995	7669	38.7

Table 2 (continued)

Patent class	Coefficients of the logistic function			Estimated year in which reached	Estimated value for 1981	7/4 in %	
	a	b	c				
				1/10c	1/2c		
	1	2	3	4	5	6	7
							8
65. Ships	48.3 (3.9)	.076 (.0020)	34887 (398)	1899	1928	33561	96.2
71. Footwear	75.5 (2.8)	.087 (.0009)	30123 (109)	1901	1926	29544	98.1
77. Sports, games and amusements	60.6 (7.1)	.085 (.0028)	60967 (746)	1899	1925	59690	97.9
78. Explosives	33.6 (2.1)	.073 (.0016)	9664 (91)	1895	1925	9329	96.5
84. Hydraulic engineering and foundations	107.9 (4.9)	.062 (.0012)	22511 (520)	1917	1963	16930	75.2
89. Sugar and starch industry	7.1 (.2)	.052 (.0011)	8331 (73)	1873	1914	7895	94.8
Total number of patent applications (1886-1973)	66.0 (2.7)	.065 (.0010)	4851460 (57614)	1907	1952	4215220	86.9
Sum of the estimates of patent applications in individ. classes (1886-1973)	50.2 (.5)	.063 (.0002)	4312370 (12200)	1904	1950	3792300	87.9
Total number of patent applications (1886-1979)	71.8 (3.3)	.067 (.0011)	4796270 (63209)	1907	1940	4205900	87.7
Sum of the estimates (1886-1979) of patent applications in individual classes	50.5 (.4)	.063 (.0002)	4288740 (12250)	1904	1939	3752640	87.5

Table 3

Trends in USA patent applications in the classes corresponding to the German classification in the period 1886-1957, on the basis of the logistic function (standard error in brackets)

Patent class	Coefficients of the logistic function			Estimated year in which reached	Estimated value for 1981	7/4 in %	
	a	b	c				
				1/10c	1/2c		
	1	2	3	4	5	6	7
							8
122. Construction 19,37,84,85	26.0 (.6)	.069 (.0007)	81226 (512)	1892	1924	79698	98.1
170. Railroads 20	19.2 (.5)	.086 (.0008)	93200 (292)	1885	1911	92980	99.8
176. Spinning I 76	11.2 (.2)	.049 (.0009)	6728 (105)	1881	1926	6298	93.6
180. Spinning II 76	18.5 (.4)	.051 (.0009)	12745 (224)	1890	1933	11770	92.3
194. Weaving 86	20.6 (1.0)	.065 (.0016)	17338 (258)	1889	1924	16953	97.8
312. Paper processes 55	30.7 (1.1)	.065 (.0011)	19693 (252)	1895	1929	19066	96.8
313. Paper products 11,54	40.6 (.8)	.064 (.0007)	23745 (221)	1900	1934	22686	95.5
324. Fertilizers 16	35.9 (1.7)	.054 (.0019)	2694 (138)	1902	1943	2397	89.0
390. Stone, clay 80	21.5 (.5)	.065 (.0008)	40466 (323)	1890	1924	39511	97.6
438. Shoemaking 71	18.0 (.4)	.060 (.0010)	18986 (270)	1888	1925	18383	96.8
444. Tobacco 79	7.9 (.4)	.051 (.0026)	4186 (148)	1874	1917	4042	96.6
458. Glass 32	15.1 (.5)	.072 (.0011)	6533 (41)	1884	1914	6481	99.2

[the figures refer to the corresponding German class(es)]



In the following pages a brief interpretation is given of the results of the estimate with regard to age at the time of the peak and the rates in the individual patent classes. The data on the age of the area of technology are summarized in Table 4 below.

TABLE 4

Sequence in which 10 % and 50 % of the upper limit were reached in the individual patent classes.

Year	10 %	50 %
1873	89	
1880	6	
1883	26	
1885	51,56	
1887	60	
1890	13,14	
1891	41,64,86	
1892	52	
1893	4	
1895	20,78,85	
1896	44,70	
1897	50,68,72	
1898	3,38	
1899	28,34,65,77,88	
1900	22,33,36,69,82	
1901	2,15,24,25,45,49,53,55,71,83	
1902	11,19,80,87	
1903	10,27,59,73,79	
1904	1,8,9,61,66,76	
1905	16,35,54,74	
1906	30,63	
1907	23,75	
1908	46,67	
1909	43	
1910	37,40	60
1911	7	26
1912	17,32,47	
1913	29,57	
1914	5,18,42	89
1916	21,31	56
1917	84	51
1919		4,6
1920	58,81	13
1922	48	
1923		20,72,88
1924	12	14,41,64

TABLE 4 (continued)

Year	10 %	50 %
1925		28,44,52,77,78
1926		13,10,70,71
1927		68
1928		2,9,24,65
1929		33,54,74
1930		15,53
1931		69,86
1932		38,87
1933		16,46,61,66
1934		1,11,30,34,36,63
1935		55
1936		67,79
1937		25,80,82
1938		43,85
1950		29,45
1951		19,23,35
1952		8
1953		17,18,49,50,57,75
1954		27,83
1955		21
1956	39	7
1957		5,22,40,73
1958		59,76
1961		37
1962		42
1963		84
1964		47,81
1966		48,31
1968		32
1972		12
1983		39
1995		58

This table shows the patent classes which in the various years reached either 10 % or 50 % of the upper limit.

The oldest class is Class 89 "Sugar and starch industry", which reached the 10 % level in 1873. In second place is Class 6 "Zymology", which reached this level in 1880. These are followed by Classes 26 "Production of gases", 51 "Musical instruments", 56 "Upholstery and saddlery" and 60 "Hydraulics and pneumatics". Most of the classes reached this level between 1895 and 1908. The youngest class of all is Class 39 "Working of plastic masses, etc.".

From Table 4, the corresponding sequence in which the patent classes reached 50 % of the upper limit can also be determined. This shows the time at which the individual classes reached their peak. In first place here is Class 60 "Hydraulics and pneumatics" in 1910. It is followed by Classes 26 "Production of gases", 89 "Sugar and starch industry", 56 "Upholstery and saddlery", 51 "Musical instruments", etc.

Most of the classes reached their maximum annual increase in patent applications between 1923 and 1958.

Class 58 "Presses" is still a long way from reaching its maximum annual number of patent applications. It is followed immediately by Classes 39 "Working of plastic masses, etc." and 12 "Chemical processes".

The comparison of the patent classes by development rates is possible on the basis of Table 5, in which the various classes were classified according to the value of parameter b.

TABLE 5

Order of the patent classes according to parameter b of the logistic function.

Range	Patent classes
> .039	50, 58, 59
> .049	6, 8, 12, 22, 27, 31, 32, 37, 47, 49 73, 76, 83, 85, 86, 89
> .059	5, 19, 23, 25, 34, 35, 36, 38, 40, 42, 48, 51, 52, 55, 64, 75, 79, 80, 81, 82, 84
> .069	1, 3, 7, 11, 13, 15, 17, 18, 20, 21, 30, 33, 39, 41, 43, 44, 45, 53, 56, 57, 61, 63, 66, 67, 68, 69, 70, 78, 87
> .079	2, 4, 16, 24, 28, 29, 65, 72
> .089	9, 46, 54, 60, 71, 74, 77, 88
> .099	10, 14

The three classes with the slowest development are Classes 50 "Grinding and pulverizing", 58 "Presses" and 59 "Pumps". Classes 10 "Fuels" and 14 "Machines or engines in general" developed the most rapidly.

THOMAS GALBRAITH IN LONDONDERRY (IRELAND).

Heissluftbad für Kranke.

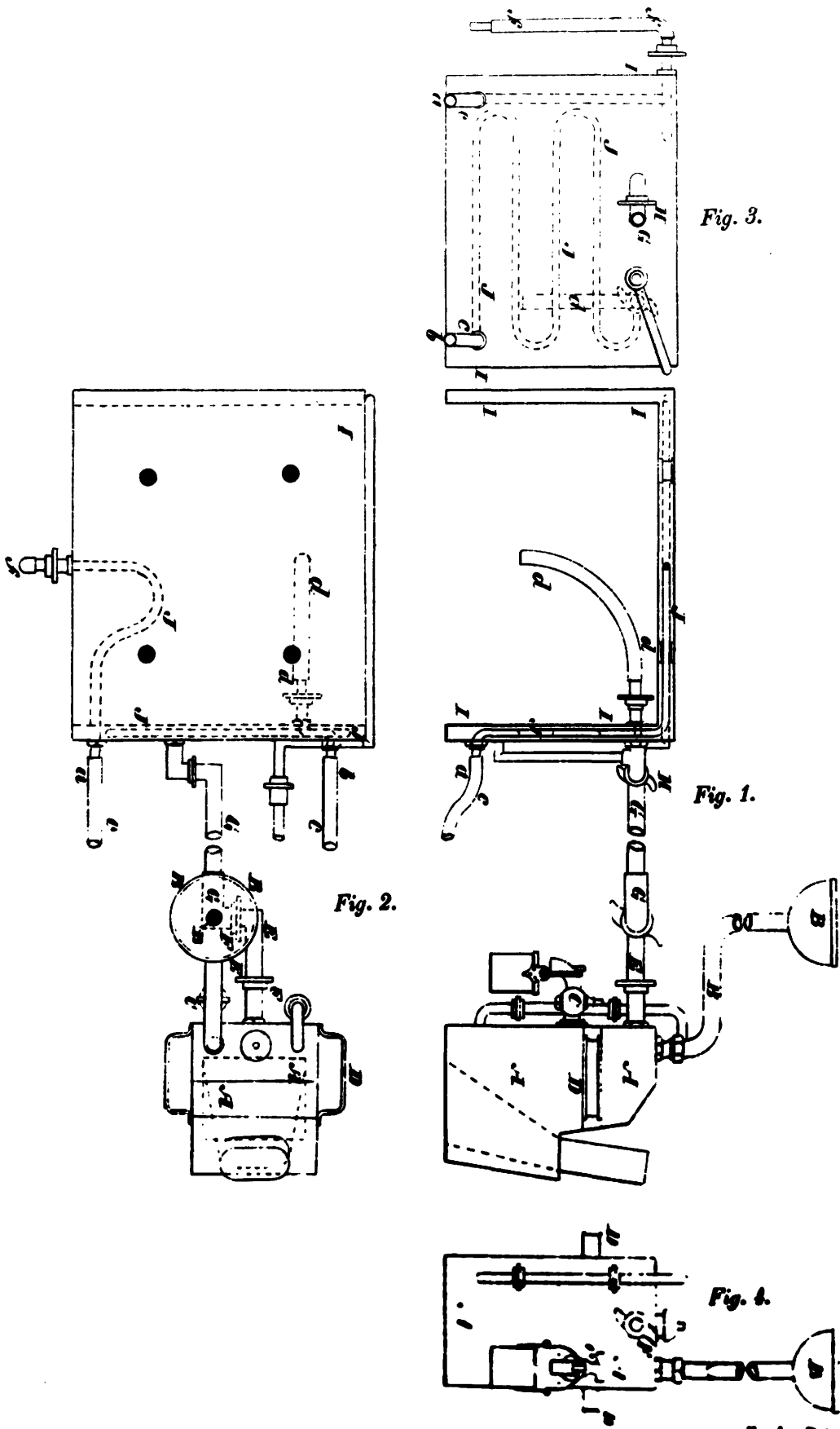

Fig. 3.

Fig. 1.

Fig. 2.

Fig. 4.

Zu der Patentschrift

PHOTOGR. DRUCK DER KÖNIGL. PREUSS. STAATSDRUCKEREI.

**№ 67.**

CARL KLEMM IN RIGA.

**Muskelklopfer.**

*Fig. 1.*

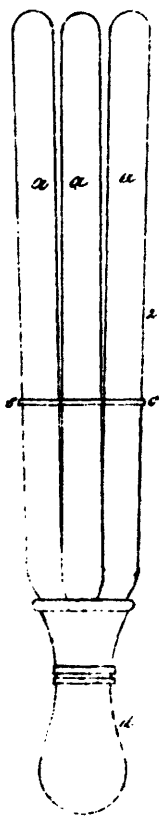

*Fig. 3.*

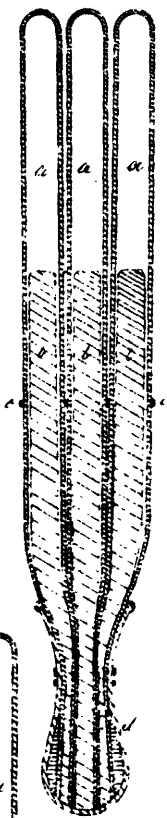

*Fig. 2.*



*Fig. 4.*

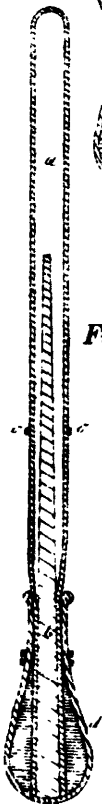

Zu der Patentschrift

**№ 153.**

PHOTOGR. DRUCK DER KÖNIGL. PREUSS. STAATSDRUCKEREI.

The classes which developed relatively quickly include Classes 46 "Combustion engines", 60 "Hydraulics and pneumatics", 71 "Footwear", 74 "Signalling" and 88 "Machines driven by wind, etc."

In the following pages, trends in patent applications in the various classes are analysed on the basis of the time series and the estimated parameters of the logistic function.

Class 1 "Preparation of ores, etc." clearly reached its peak in the first half of the 1930s. Up to that time, patent applications showed a rising trend but then clearly began to drop off.

The same pattern is also shown by Class 2 "Baking", although it reached its peak somewhat earlier, i.e. in the second half of the 1920s.

Even older is Class 3 "Wearing apparel", which reached its peak as early as the period before the First World War.

Class 4, which covers lighting through fuels, etc., reached its peak in the second decade of this century. This trend reflects the rivalry between gas and electric lighting. The battle was decided first and foremost by the invention of the process for the production of tungsten wire, which could be used in the manufacture of the actual bulbs.

Class 5 "Mining" did not reach its peak until after the Second World War.

The maximum annual number of patent applications in Class 6 "Zymology" is not clearly discernible. The trend in this time series is dominated by a number of relatively long waves in the annual number of patent applications. The peak of the first wave is at the beginning of this century, while the second and third waves peak at the end of the 1920s and in the 1970s, respectively.

Class 7 "Mechanical metal working without essentially removing material" seems to be still on an upward trend.

Class 8 "Bleaching, washing, dyeing, printing of cloth and tapestry and finishing" seems to show a similar trend.

Inventive activity is clearly on the wave in Class 9 "Brushware", which reached its peak in the second half of the 1920s.

Class 10 "Fuels" also seems to have reached its peak in the 1920s, as does Class 11 "Bookbinding, etc."

One of the classes with the biggest growth which have probably not yet reached their peak is Class 12 "Chemical processes and apparatuses". Of note is the increase in this class's share of the total number of patent applications. At the beginning of our time series this share was a little over 1 %, whereas at the end this class accounted for almost 10 % of the total number of patent applications in the Federal Republic of Germany.

Class 13, which covers steam boilers, reached its peak in the first half of the 1920s, Class 14 "Machines or engines in general" somewhat earlier.

Class 15 "Printing" peaked at the end of the 1920s, shortly before the beginning of the great world economic crisis. Class 16 "Manufacture of fertilizers" also reached its peak at the same time.

Class 17 "Refrigeration or cooling, storage of ice, heat transfer, etc." seems to be gaining fresh impetus over and over again. Its share of the total number of patent applications shows a rising trend and in the 1970s exceeded its pre-war peak.

Class 18 "Metallurgy of iron" seems to have reached its peak after the Second World War at the end of the 1950s. The drop in patent applications in this class seems unstoppable in the last two decades.

Class 19 "Construction of roads, railways and bridges" reached its peak at the beginning of the 1930s. However, the drop in the number of patent applications per year did not continue after the Second World War. The situation in Class 20 "Railway transport" seems very clear : the peak was reached in the mid-1920s. Since that time the annual number of patent applications has been steadily falling, although this trend has slowed down since the Second World War.

Class 21 "Electrical engineering" shows a trend similar to that of Class 12 "Chemical processes". This class too has acquired an increasing share of the total number of patent applications. With a share of around 14 % in the 1970s, this class took the lead in the patent classification. Nevertheless, certain signs of exhaustion have become apparent here, too, in the last two decades.

Class 22 "Dyes, paints, etc." reached its first peak at the end of the 1920s. After the Second World War it was given a fresh boost which took it beyond the pre-war peak.

Class 23 "Oils and fats" has been around its peak in the last couple of decades.

The classes showing a clear trend include Class 24 "Furnaces, etc.", whose peak was indisputably in the 1920s.

Class 25 "Braiding, lace-making, knitting, etc." reached its peak before the Second World War.

The trend in Class 26 "Production of gases" is closely linked to that in Class 4, which includes gas lighting in particular. This class had an exceptional upswing around the turn of the century. After the final victory of electric lighting, it too has stagnated, albeit over a long period.

A long-term rise until the mid-1950s is shown by Class 27 "Fans, air pumps and compressors".

Class 28 "Tanning and treatment of skins and hides, leather industry" is one of the classes which have long since passed their peak; this particular class reached its peak in the 1920s.

Class 29 "Yarns" has been around its peak since the 1930s.

Although Class 30 "Medical science" reached its peak before the Second World War, it has shown a further upswing since the mid-1960s. This is obviously linked to the introduction of patent protection of chemical compounds.

Class 31 "Industrial furnaces; casting; powder metallurgy", which showed moderate growth for decades, showed a significant upturn in the 1960s and 1970s. This is obviously due to developments in the field of powder metallurgy.

Class 32 "Glass; mineral and slag wool" gives the impression of a technological breakthrough. This class perhaps provides a good example of the conversion of the traditional logistic function into a series of logistic functions, i.e. a step function.

Class 33 "Hand and travelling articles" has been on the decline since the beginning of the 1930s. Its share of the total number of patent applications has also been falling steadily. The same applies to Class 34 "Furniture; domestic articles or appliances".

Although Class 35 "Lifting gear" reached its peak before the war, it has since remained at more or less the same level. Class 36 "Heating, ventilation, hot water supply in buildings" also reached its peak before the Second World War.

Class 37 "Building" clearly shows a rising trend.

The trend in Class 38 "Wood working by mechanical and chemical means" follows the well-known pattern, with a clear decline after the Second World War. This class reached its peak before the war, namely at the end of the 1920s. Its share of the total number of patent applications is falling year by year.

Class 39 "Working of plastic masses" is one of the most expansive classes in the whole patent classification. Over the hundred years analysed, its share of the total number of patent applications has risen from a few per thousand to more than 5 % in the 1970s. Only in the last decade a fall-off in the growth rate is apparent. It is impossible to say, however, to what extent this is due to long-term and/or cyclical causes.

Class 40 "Metallurgy other than of iron" is going through a second upswing. It seemed to have reached its peak before the war, but it has gained fresh impetus since the end of the Second World War.

Class 41 "Headwear, felts" is one of the classes which have long since passed their peak. However, the trend in this class shows two peaks, namely shortly before the First World War and at the end of the 1920s. Since then, its decline seems unstoppable. This is also reflected in its steadily declining share of the total number of patent applications.

Class 42 "Instruments" is one of the most dynamic classes. Its share of patent applications has grown from around 3 % at the beginning of our time series to over 8 % in the 1970s.

Class 43 "Checking devices" is characterized by a series of long waves. The corresponding peaks came in the mid-1900s, at the end of the 1920s and in the mid-1960s.



Class 44 "Haberdashery, jewellery, snuff takers' and smokers' requisites" reached its peak at the beginning of the 1920s, with more than 1000 patent applications per year; since then it has been in decline in both absolute and relative terms.

The greatest number of patent applications in the agricultural sector (Class 45) was reached at the end of the 1920s. Since then, the number of applications in this class has been falling not only in absolute but also in percentage terms.

In Class 46 "Combustion engines" innovation potential reached its peak in the 1920s. Up to that time, this class increased its share of patent applications from around 1.3 % to over 4 %. This was followed by a decline in both absolute and relative terms, bringing this class's share down to almost its original level.

Class 47 "Engineering elements or units", which covers general inventions in the field of mechanical engineering, is one of the classes to show growth over the whole reference period. The rise is even sharper in Class 48 "Working and treatment of metals other than by mechanical means". As this class covers mainly chemical and electrical methods of metal working, it is understandable that it shows a trend similar to that of the classes "Chemical processes" and "Electrical engineering".

Class 49 "Machine tools" still shows an upward trend, although its rate of growth has slowed down since the war.

Class 50 "Grinding and pulverizing" reached its peak shortly after the Second World War. Since then, it has been declining both in absolute and in relative terms.

Class 51 "Musical instruments", characterized by a relative decline over the whole of the reference period, has shown a downward trend in absolute terms too since the mid-1920s. Class 52 "Sewing and embroidering" covers a fairly old and technically exhausted branch. Its peak came before the First World War and its share of patent applications shows an almost uninterrupted decline.

Class 53 "Foods and foodstuffs" clearly reached its peak before the Second World War, namely at the beginning of the 1930s. The same applies to Class 54 "Working of paper and board and products thereof". Class 55 "Production of cellulose, paper and board" shows a fairly similar trend, although it has differed since the Second World War. Whereas Class 54 is characterized by a clear decline, the trend in Class 55 can be described as stagnating.

Class 56 "Upholstery and saddlery" reached its peak as early as the first decade of this century. Of note is a temporary rise in the second half of the 1920s.

Class 56 "Photography, cinematography and sound film" shows two clear peaks : the first at the beginning of the 1930s, the second in the 1970s following an uninterrupted rise in the post-war period. A class which has shown a clear upward trend in the last couple of decades is Class 58 "Presses".

Class 59 "Fluid pumps and other hydraulic lifting devices" shows three clear peaks : the first shortly before the First World War, the second at the end of the 1920s and the third in the mid-1960s.

Class 60 "Fluid-pressure actuators, hydraulics and pneumatics" has shown a dramatic rise since the end of the 1960s. This is obviously linked to the development of automation.

The picture in Class 61 "Life-saving and fire-fighting" is characterized primarily by a sharp rise in the period between the two wars. This rise interrupted the steady decline in this class's share of the total number of patent applications for a couple of decades.

Class 62 "Aviation" was not made a separate class until after the First World War. Its upward trend was unusually dynamic, but after the defeat of Germany it was unable to regain its former level. Although the number of patent applications is rising, the rate is slower and at a much lower level than before the Second World War. This is without doubt a reflection of the special conditions for the development of this branch in post-war Germany.

Class 63 "Trackless vehicles" reached its peak in the period between the two wars, namely in the second half of the 1920s.

Class 64 "Distribution of alcoholic liquors" shows two peaks : the first before the First World War, the second at the beginning of the 1930s. Its share of patent applications shows a more steady decline.

The number of patent applications in Class 65 "Ships and other waterborne vehicles" peaked shortly before the First World War, with a second rise at the end of the 1920s. The peak for Class 66 "Butchering and meat treatment" came at the end of the 1920s and at the beginning of the 1930s slightly overlapping the period of economic crisis. A similar trend can be seen in Class 67 "Grinding and polishing".

The peak in Class 68 "Articles of the locksmithing trade" came somewhat earlier, namely at the beginning of the 1920s.

A clear trend is shown by Class 69 "Cutting tools", with an upward movement up to the beginning of the 1930s. After the Second World War there was a clear decline, but this seems to have been halted since the beginning of the 1960s.

Class 70 "Writing and drawing appliances" reached its peak at the beginning of the 1920s.

Class 71 "Footwear" shows a clearly logistic trend pattern. Its peak came in the 1920s.

It comes as no surprise that the trend in patent applications in Class 72 "Firearms, ammunition, fortifications" is closely linked to the wars. The rise a few years before the First World War seems to herald this war. Contrary to the trend in most of the other classes, the number of patent applications continued to rise during the First World War.

The clear rise in the number of patent applications in this class in the 1930s is also highly significant. After the Second World War the trend in this class no longer seems to be a sensitive indicator of the war situation. On the one hand, other weapons seem to be more appropriate in this respect, while on the other hand the significant inventions are apparently not patented as they were before. In addition, Germany is no longer representative of the production of war weapons.

In view of its minor importance, Class 73 "Ropes" is not surprisingly one of the classes which barely show a significant trend.

The trend in Class 74 "Signalling" reached its peak in the period before the Second World War, namely at the end of the 1920s.

Class 75 "Sculpture, painting, ornamentation of surfaces" shows three peaks : the first at the end of the 1900s, the second at the end of the 1920s and the third in the mid-1960s. This class's share of the total number of patent applications shows no significant variations. Class 76 "Spinning" reached its peak after the Second World War. It has remained around this level in the last couple of decades.

The trend in Class 77 "Sports, games and amusements" is obviously distorted because up to the beginning of the 1920s inventions in the field of airship navigation were also included in it. This explains the rapid growth of patent applications in this class in the first two decades of the century.

Some of the comments concerning Class 72 "Firearms" also apply to Class 78 "Explosives, etc.". At least for the period before the First World War, and for the war years, the connection with the war preparations and the conduct of war is quite clear. However, a similar trend is not apparent for this class in the 1930s.

Class 79 "Tobacco, cigars, cigarettes" reached its peak at the end of the 1920s and at the beginning of the 1930s, as did Class 80 "Clay articles, stones, chalk, cement etc".

Class 81 "Transport and packing" is one of the classes to show growth over the whole period. Class 82 "Drying" shows a decline in relative terms over the whole period and in absolute terms starting at the end of the 1920s. Although Class 83 "Measurement of time" reached its peak before the Second World War, it has shown a further upward trend since the mid-1960s.

The trend in Class 84 "Hydraulic engineering and foundations" is obviously linked to general economic trends. Class 85 "Mineral and soda water, water purification, water supply and sewerage" shows three peaks : the first at the end of the 1900s, the second directly before the economic crisis at the end of the 1920s and the third in the first half of the 1970s.

One of the branches which showed a further upward trend over one or two decades is Class 86 "Weaving". This branch reached its first peak around 1910 and its second at the beginning of the 1930s. A similar trend is shown by Class 87 "Tools and implements". A number of technological breakthroughs can be seen in Class 88 "Machines driven by wind or water power". A further upswing seems to be in the offing in recent years.

The last class in the patent classification is Class 89 "Sugar and starch industry" which can be regarded as one of the oldest. Its peak came at the beginning of our reference period, and since then this class has been at a steady decline in both absolute and relative terms.

*Comparison of the Estimated Results of the Logistic Function for Two Different Reference Periods*

For some of the patent classes it was possible to show trends in patent applications beyond the period covered by the German patent classification, i.e. up to 1980. Approximately a third of the total number of patent classes are involved.

In general, the estimates remain very stable. This can be verified for individual classes by comparing the year in which 50 % of the upper limit  $c$  was reached.

For the various classes these years are as follows :  
 (The first year refers to the estimate with the reference period up to 1973, the second to that with the reference period up to 1980).

Class 2	"Wearing apparel"	1926, 1926
Class 5	"Mining"	1957, 1957
Class 7	"Mechanical metal working"	1951, 1956
Class 9	"Brushware"	1928, 1928
Class 14	"Machines or engines in general"	1918, 1924
Class 16	"Manufacture of fertilizers"	1931, 1933
Class 18	"Metallurgy of iron"	1953, 1953
Class 19	"Construction of roads, railways and bridges"	1938, 1951
Class 22	"Dyes"	1951, 1957
Class 32	"Glass"	1963, 1968
Class 34	"Furniture"	1932, 1934
Class 35	"Lifting gear"	1937, 1951
Class 37	"Building"	1959, 1961
Class 40	"Metallurgy other than of iron"	1955, 1957
Class 41	"Headwear"	1923, 1924

Class 44	"Haberdashery"	1923, 1925
Class 45	"Agriculture"	1932, 1950
Class 46	"Combustion engines"	1931, 1933
Class 47	"Engineering elements or units"	1961, 1964
Class 48	"Working and treatment of metal other than by mechanical means"	1972, 1966
Class 49	"Machine tools"	1950, 1953
Class 58	"Presses"	1970, 1995
Class 65	"Ships"	1926, 1928
Class 71	"Footwear"	1925, 1926
Class 77	"Sports"	1923, 1925
Class 78	"Explosives"	1923, 1925
Class 84	"Hydraulic engineering and foundations"	1960, 1963
Class 89	"Sugar and starch industry"	1914, 1914

*Comparison of Trends in Germany and America*

Table 3 sets out the results of the estimate of the logistic function for certain USA patent classes which are comparable with the German patent classes. The comparison can be made in respect of all the estimated parameters. Here it is limited to the time at which 50 % of the upper limit was reached in one country or the other.

The German classes 19, 37, 84 and 85 are comparable with the class "Construction", which reached its peak in 1924; they reached 50 % of the upper limit in 1938, 1959, 1960 and 1938, respectively.

German patent Class 20, which reached its peak in 1923, is comparable with the patent group "Railroads", which in the USA reached its peak in 1911.

Two American classes cover "Spinning", reaching their peak in 1926 and 1933, respectively. The corresponding German Class 76 reached its peak in 1958.

The American class "Weaving" reached its peak in 1924, the corresponding German patent Class 86 in 1931.

The American Class 312 reached its peak in 1929, the comparable German Class 55 "Production of cellulose, paper and board" in 1935. The peak for paper products came in 1934 in the USA, compared with 1929 in the corresponding Class 54 in Germany.

The American class "Fertilizers" reached its peak in 1943 and is comparable with Class 16 in the German patent classification, which reached its peak in 1933.

Class 390 in America reached its peak in 1924, whereas the comparable German Class 80 "Clay articles, etc." did not do so until 1937.

The patent class "Shoemaking" reached its peak in 1925 in the USA, as did the comparable German Class 71. The American Class 444 reached its peak in 1907, whereas the corresponding Class 79 in Germany "Tobacco, cigars, cigarettes" did not do so until 1936.

Lastly, Class 458 in the USA reached its peak in 1914, whereas the corresponding German Class 32 "Glass" did not do so until 1963.

It can be seen on the whole that America was somewhat ahead of Germany. With one or two exceptions, the peaks in the corresponding American patent classes were reached several years earlier than in Germany. This observation is in keeping with the USA's presumed technological lead in most areas and increases confidence in the information provided by the time series of patent applications.

*B. Analysis and Interpretation of Trends in Patent Applications on the Basis of the Spline Function \*)*

Up to the end of the Second World War the time series of patent applications refer mainly to the territory and population of the German Reich and after the Second World War to the territory and population of the Federal Republic of Germany. This analysis does not take account of minor adjustments connected with the outcome of the First World War and later with the annexation of Austria and the establishment of the Protectorate of Bohemia and Moravia.

This undoubtedly complicates the analysis of trends in patent applications and comparison of the figures for before and after the Second World War.

---

\*) By using the *spline* function in the calculation of time trends, different trend periods can be smoothly connected together. For this purpose the time variable, which in the trend functions serves as an independent explanatory variable, is replaced by a number of time variables which always have their beginning at the time of the trend turning point. In our trend calculation, the first time variable begins in 1877 with the value 1 and the second trend variable in 1953 (1953 = 1).

The English word "*spline*" means to wedge or groove. It was taken from shipbuilding and designates a way of making the continuously curved outer shells of ships from wood or metal by bending round a rigid support.

The most important factor affecting a comparison of this type is the existence of the German Democratic Republic. The number of patent applications by nationals would be greater if it referred to the total population of both German states and not only to that of the Federal Republic. Apart from the existence of the GDR, the comparison with the pre-war period is affected by other population trends in the war years and the immediate post-war period, namely the population losses as a result of the war and the expulsion of the German population from the eastern European countries. It should be noted here that the refugees came not so much from the Reich territory but rather from other territories such as Czechoslovakia and Poland.

This study does not try to take all these processes into account and calculate their influence on trends in patent applications. A calculation of this type is absolutely impossible. The only possibility is a hypothetical calculation that can give some idea of the magnitude of this influence.

By and large, it is sufficient to consider just the existence of the GDR for this purpose. In this way account is also taken of the proportion of expellees from the East in the population of the two German states.

Two different methods were used to arrive at a rough estimate of the magnitude of these influences : one possibility was to add domestic patent applications in the GDR to those in the Federal Republic. The second was to carry out a conversion on the basis of the population figures of the two German states.

For example, in 1970 approximately 66,000 patent applications were filed in the Federal Republic. Roughly 35,000 of these were from foreigners, including around 1300 from citizens of the GDR. In this year, the population of the Federal Republic was 60.71 millions and that of the GDR 17.06 million. If the number of domestic patent applications is now increased in line with these population ratios and the patent applications from the GDR in the Federal Republic are deducted, the total number of patent applications goes up from 66,000 to approximately 74,000. It thus seems that under conditions comparable with these in the pre-war period the total number of patent applications after the war was roughly 10 % higher.

In order to check this calculation, the comparison with the number of domestic patent applications in the GDR can also be used. In the 1960s and 1970s, this number fluctuated between 4,000 and 6,000 per year and is thus somewhat lower than our calculated figure, but not in rank. The lower intensity of patent applications in the GDR compared with the Federal Republic may be linked to various factors which will not be discussed in detail here, e.g. the economic structure, the distribution of specialists and their training, the nature and tendencies of the economic system, etc.

On the basis of this approximate comparison, it can, however, be stated in general that the variation in relevance for our purposes does not amount to much more than 10 % of the total number of patent applications in the Federal Republic. It is also important to note that our analysis is concerned more or less with changes of the level between the pre- and post-war periods and not so much with recurring long-term trends.

The present calculation refers to the total number of patent applications.

It is not assumed, however, that the factors analysed have the same effects in all patent classes. Rather it can be assumed that in some classes - as a result of the different economic structure of the Federal Republic - the proportions have systematically moved either upwards or downwards compared with pre-war Germany.

The structural break in the trend for certain patent classes was taken into account in the calculation of trends in individual classes by means of a spline function. In most cases, the role of the areas of technology and production branches in overall technological development has systematically changed over the last 100 years analysed. Only a small group of patent classes (approximately a tenth) shows no systematic change of the trend during the reference period. In most cases, the development of the number of patent applications in the individual classes as a proportion of the total number of patent applications shows clear trends. The patent classes which show only a single time trend include, for example, Nos 69 "Cutting tools", 20 "Railway transport", 55 "Production of cellulose, paper and board", 44 "Haberdashery, etc.", 4 "Lighting through fuels and pre-heating torches", 80 "Clay articles, etc.", 34 "Furniture", 83 "Measurement of time" and 76 "Spinning".

Many other patent classes show two or more time trends : for example, the trend in Class 39 "Working of plastic masses, etc." shows three periods.

Between 1885 and the beginning of the Second World War this class's share of all patent applications rises steadily. After the Second World War, this trend gathers considerable pace until round about the beginning of the 1960s, after which it stagnates. A steady increase in its share of total applications is also shown by Class 42 "Instruments". The positive trend in this class was even more marked after the Second World War. The steady increase for Class 81 "Transport" is exceptionally clear. Here again, there was a marked speeding up after the Second World War.

We shall also give some examples of negative trends. The patent classes concerned are those whose share of the total number of patent applications fell consistently. Here too, a distinction can be made between cases showing a single significant time trend and those with one or more trend shifts and two or more trend lines. Whereas in Class 80 "Clay articles" or Class 34 "Furniture" there is only one significant trend, Class 38 "Wood working", for example, shows a faster decline in its share of total patent applications after the Second World War.

In many patent classes, there was a positive or negative shift in the trend level after the Second World War, e.g. Class 38 "Wood working". The trend after the Second World War in this class does not show a continuation of the pre-war trend line. The section after the Second World War shows an upward shift. However, the fall was sharper after the Second World War. Like many others this case reflects an important fact, namely that the situation after the Second World War is brought out in the Federal Republic of Germany by a structural change of the production of technological know-how. This fact is clearly expressed in the diagrams for individual classes and could also be quantified on the basis of the calculation of the trend function. The causes of shifts of this kind are linked on the one hand to the above-mentioned changes of the territory and population of the Federal Republic of Germany compared with pre-war Germany and, on the other hand, to developments in the rest of the world, from which Germany was cut off for almost 20 years.



In order to take account of the most important developments in the structure of patent applications in the last hundred years and above all to consider the clusters in this pattern, a modified trend function was calculated. Instead of calculating a simple dynamic time trend function of individual classes' shares of patent applications, a spline time trend function (which makes it possible to record at least one trend shift) was calculated for the most important period in which there were many breaks in the pattern, namely after the Second World War. The spline function, which calculates two time trends, was further modified by using a dummy variable for the period after 1953 in order to also take account of upward or downward shifts in the trend level after the Second World War.

The formula for the estimated time trend function is as follows :

$$\hat{k}_n = \hat{a}_0 + \hat{a}_{53}D_{53} + \hat{b}_1t + \hat{b}_{53}t_{53}$$

in which :

$\hat{k}_n$	= patent classes' estimated share of the total number of patent applications
$D_{53}$	= dummy variable for the years after and including 1953
$t$	= time variable
$t_{53}$	= spline time variable for the years from 1953 onwards
$\hat{a}_0, \hat{a}_{53}, \hat{b}_1, \hat{b}_{53}$	= estimating coefficients

The results of the estimate of this modified time trend function are set out in Table 6 showing the following statistical values (see pp. 83 - 85).

The constant of the function denotes the estimated share of the corresponding patent class at the beginning of the time series, e.g. 4.31 per 1000 for Class 75 "Sculpture". This value can be compared with the mean value of the class's shares, denoted in the last column by MV.

We have already mentioned a clear shift in level after the Second World War in Class 38 "Wood working". At the beginning of the time series the value of the constant is 14.91 for the trend level. After the Second World War this level moves upwards by 6.32 per 1,000, as shown in the dummy 53 column. The third column shows the value of the time trend. The figure given shows by how many per thousand the share of the relevant patent class moves upwards or downwards in a year. In the fourth column the change of the time trend is calculated, beginning in 1953. For the period after the Second World War this figure must be added to the value of the time trend in the third column. This can be illustrated by the example of Class 3 "Wearing apparel".

CARL BENDER IN SONNENBERG.

Glasverfittungsmaschine.

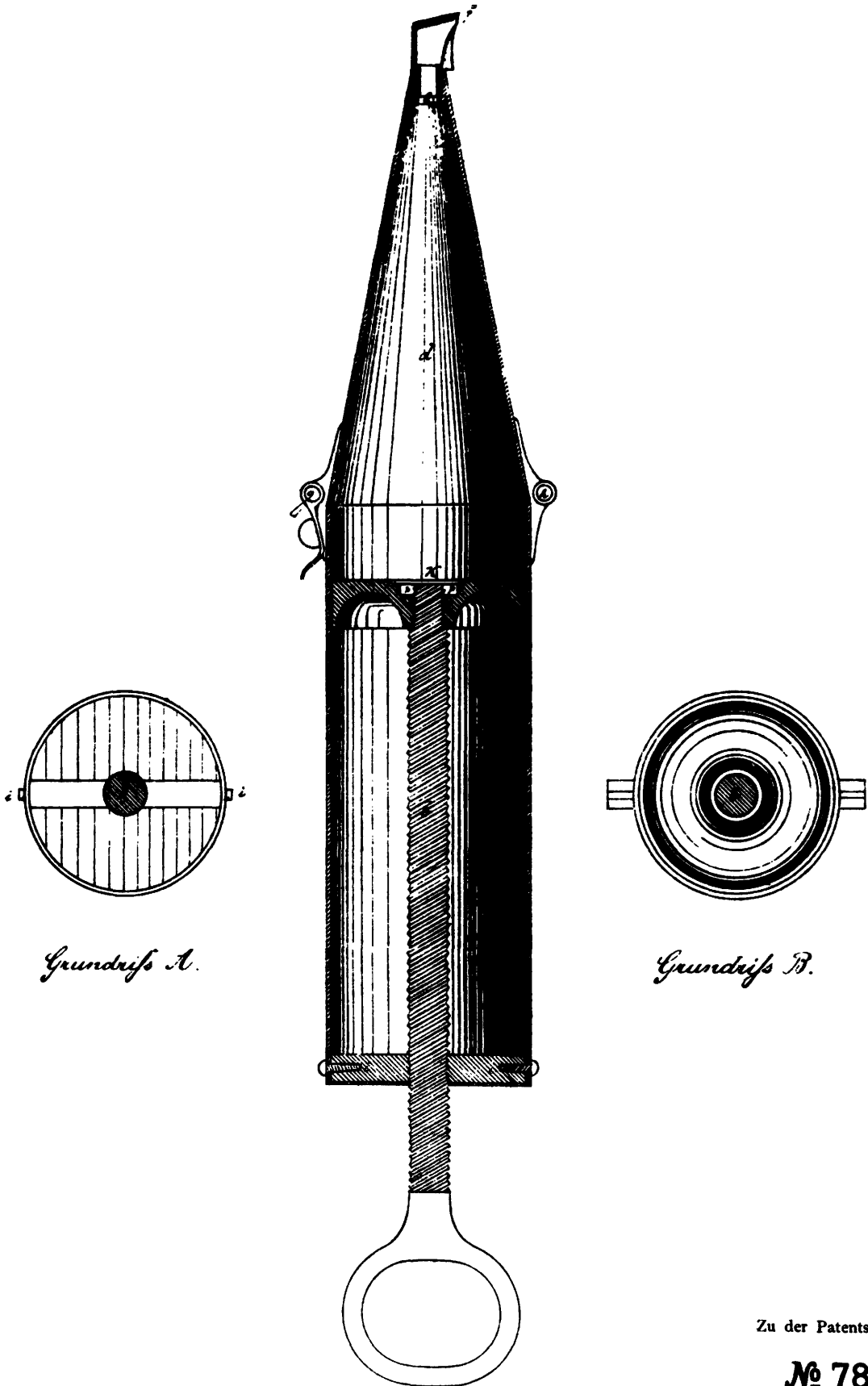

*Grundriss A.*

*Grundriss B.*

Zu der Patentschrift

**№ 78.**

PHOTOGR. DRUCK DER KÖNIGL. PREUSS. STAATSDRUCKEREI.

I. HAILER IN ESSLINGEN (WÜRTEMBERG).

Reise- und Feldbecher.

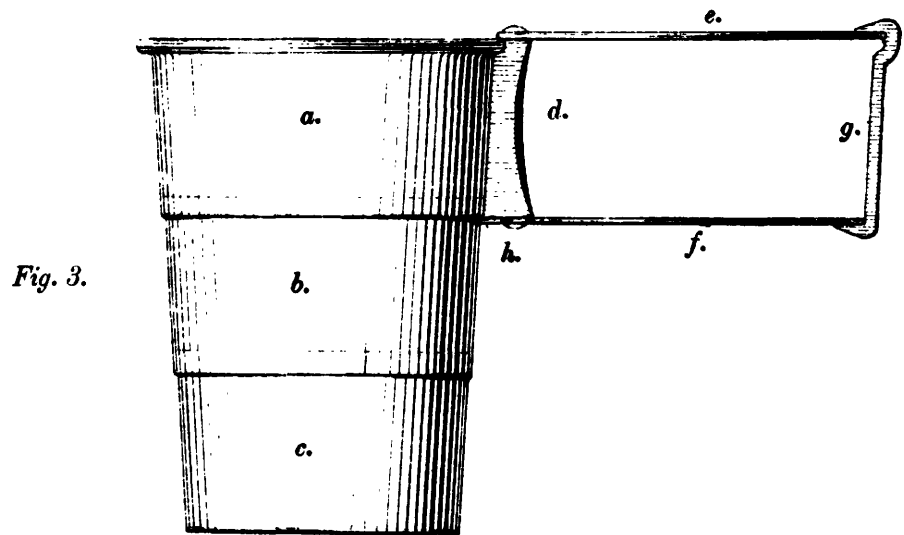
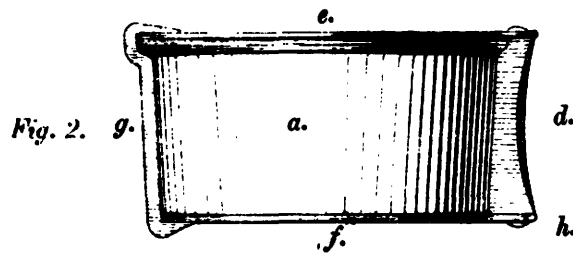
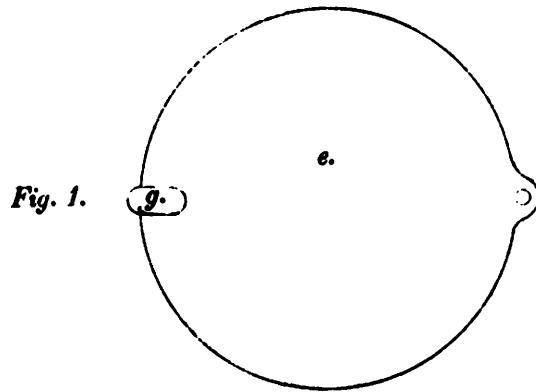

Zu der Patentschrift

PHOTOGR. DRUCK DER KÖNIGL. PREUSS. STAATSDRUCKEREI.

№ 68.

TABLE 6

Parameters of the trend function of the proportion (per 1,000) of patent applications by class in the total number of patent applications in Germany (FR) in the period 1885 - 1974 (t-statistics in brackets).

Class	Con- stant	Dummy 53	Time trend	Change in time trend in 1953	R <sup>2</sup> DW	F-Sta- tistics	MV SD
<u>Group 1</u> (only constant significant)							
75. Sculpture	4.31 (7.4)	-.47 (.5)	.019 (1.3)	-.056 (.9)	.089 .12	3.5	5.31 1.79
<u>Group 2</u> (only constant and dummy 53 significant)							
15. Printing	15.73 (23.8)	-6.02 (5.3)	.007 (.4)	.013 (.2)	.617 .14	41.3	14.41 3.15
65. Ships	11.28 (12.5)	-6.42 (4.1)	.013 (.6)	-.012 (.1)	.470 .09	23.2	10.13 3.66
72. Firearms	16.02 (6.4)	-9.12 (2.1)	-.045 (.7)	.132 (.5)	.257 .20	9.7	11.56 8.55
77. Sports	20.16 (6.8)	-11.06 (2.2)	.036 (.5)	-.189 (.6)	.243 .06	9.0	18.15 10.01
79. Tobacco	2.79 (18.2)	-.67 (2.6)	.006 (1.5)	-.001 (.1)	.120 .14	4.4	2.89 .48
88. Machines (excluding 46, 14)	4.25 (13.4)	-2.14 (3.9)	-.005 (.7)	-.026 (.8)	.634 .11	44.3	3.27 1.55
<u>Group 3a+</u> (Dummy 53+ significant, time trend and change +)							
39. Working of plastic masses	1.05 (1.0)	14.07 (8.0)	.148 (5.6)	1.512 (14.4)	.975 .09	968.2	17.64 19.10
42. Instruments	28.02 (25.8)	2.98 (1.6)	.243 (8.7)	.915 (8.2)	.942 .13	408.0	44.21 13.35
48. Work & treatm. of met- al other than by mechanical means	1.96 (9.8)	2.47 (7.2)	.033 (6.4)	.075 (3.7)	.941 .18	402.8	4.58 2.44
81. Transport	2.75 (7.2)	1.24 (1.9)	.306 (31.0)	.147 (3.7)	.986 .21	1812.1	19.08 9.70
<u>Group 3a -</u> (Dummy 53- significant, time trend and change +)							
31. Ind. furnaces; casting; powder metallurgy	3.82 (12.4)	-1.25 (2.4)	.023 (2.9)	.320 (10.2)	.836 .17	128.1	5.68 2.24
57. Photography, cinemat- ography & sound film	1.13 (1.6)	-12.24 (9.8)	.353 (17.9)	.159 (2.1)	.877 .13	178.8	15.06 6.10
84. Hydraulic engineering and foundations	1.14 (8.3)	-.48 (2.0)	.049 (13.6)	.029 (2.0)	.912 .15	249.2	3.55 1.35
<u>Group 3b +</u> (Dummy 53+ significant, time trend + and change -)							
5. Mining	4.20 (11.6)	7.39 (11.9)	.039 (4.2)	-.420 (11.4)	.849 .17	141.1	6.92 2.74
18. Metallurgy of iron	1.70 (4.5)	1.62 (2.5)	.094 (9.5)	-.309 (7.9)	.751 .09	76.5	5.86 2.26
<u>Group 3b -</u> (Dummy 53- significant, time trend + and change -)							
2. Baking	3.54 (16.6)	-1.59 (4.3)	.013 (2.4)	-.085 (3.9)	.673 .17	52.5	3.46 1.10
7. Mechanical metal working	1.52 (2.1)	-4.91 (3.9)	.177 (9.4)	-.110 (1.5)	.611 .10	40.3	8.69 3.45
9. Brushware	2.33 (16.5)	-1.90 (7.8)	.028 (7.6)	-.106 (7.3)	.818 .18	113.4	2.83 .98
10. Fuels	3.44 (9.7)	-4.30 (7.1)	.049 (5.4)	-.144 (4.0)	.726 .12	67.4	4.20 2.00
16. Manufacture of fertilizers	1.59 (10.6)	-.67 (2.6)	.009 (2.4)	-.048 (3.1)	.429 .17	18.1	1.72 .58
17. Refriger./cooling, stor- age of ice, heat trans- fer	2.38 (9.8)	-1.06 (2.5)	.093 (14.8)	-.108 (4.3)	.845 .13	137.0	6.40 1.82
21. Electrical enginner- ing	3.50 (1.0)	-21.33 (3.6)	2.191 (24.7)	-2.014 (5.7)	.947 .06	448.6	101.36 44.07
24. Furnaces etc.	13.38 (14.7)	-4.93 (3.1)	.039 (1.7)	-.357 (3.8)	.610 .08	40.1	12.75 4.32
29. Yarns	.35 (1.5)	-2.47 (6.1)	.078 (12.9)	-.027 (1.1)	.745 .25	74.1	3.48 1.37

Table 6  
(continued)

Class	Con- stant	Dummy 53	Time trend	Change in time trend in 1953	R <sup>2</sup> DW	F-Sta- tistics	MV SD
30. Medical science	14.40 (18.5)	-5.61 (4.2)	.192 (9.6)	-.489 (6.1)	.590 .09	37.0	20.87 3.59
43. Checking devices	-.04 (.1)	-3.99 (3.0)	.153 (7.7)	-.232 (2.9)	.454 .09	21.8	5.76 3.08
46. Combustion engines	8.74 (6.6)	-22.41 (9.8)	.514 (15.0)	-.937 (6.9)	.785 .08	92.4	25.14 8.47
53. Food and foodstuffs	10.62 (11.2)	-3.67 (2.2)	.014 (.6)	-.155 (1.6)	.370 .15	15.7	9.75 3.53
54. Working of paper and board	7.31 (16.1)	-8.28 (10.6)	.133 (11.4)	-.358 (7.7)	.846 .17	138.8	10.44 3.42
53. Trackless vehicles	27.36 (7.3)	-16.66 (2.6)	.563 (5.8)	-1.400 (3.7)	.335 .13	13.6	46.32 13.53
67. Grinding	2.63 (14.7)	-1.01 (3.3)	.060 (13.0)	-.159 (8.7)	.729 .18	68.4	4.83 1.01
71. Footwear	9.58 (10.8)	-5.92 (3.9)	.036 (1.6)	-.213 (2.3)	.572 .11	34.4	8.99 3.99
74. Signalling	3.79 (8.6)	-7.45 (9.8)	.133 (11.7)	-.237 (5.2)	.759 .08	79.8	7.56 2.66
<u>Group 3c + (Dummy 53+ significant, time trend - and change +)</u>							
6. Zymology	16.96 (37.8)	5.52 (7.2)	-.278 (24.0)	.361 (7.8)	.912 .05	260.5	5.71 4.47
8. Bleaching, washing, dyeing, etc.	20.27 (27.2)	4.22 (3.3)	-.084 (4.4)	.038 (.5)	.182 .09	6.5	17.39 2.43
13. Steam boilers	23.05 (36.0)	3.86 (3.5)	-.230 (18.2)	.162 (2.5)	.910 .09	253.6	9.54 6.30
22. Dyes, paints, etc.	25.90 (21.3)	5.90 (2.8)	-.305 (9.7)	.520 (4.2)	.602 .09	38.8	13.92 5.71
25. Braiding, lace-making, etc.	8.62 (19.2)	2.00 (2.6)	-.078 (6.7)	.042 (.9)	.459 .04	22.2	5.42 1.81
26. Production of gases	20.36 (11.4)	6.36 (2.1)	-.324 (7.0)	.245 (1.3)	.513 .14	27.3	6.66 7.58
32. Glass	4.98 (22.3)	.72 (1.9)	-.035 (6.0)	.155 (6.7)	.516 .11	27.7	3.95 .95
37. Building	23.33 (25.3)	9.56 (6.0)	-.087 (3.7)	.196 (2.1)	.623 .13	42.2	22.36 4.43
41. Headwear	2.44 (29.3)	.33 (2.3)	-.028 (13.1)	.016 (1.9)	.844 .21	135.8	1.17 .62
47. Engineering elements or units	37.56 (34.2)	10.84 (5.7)	-.065 (2.3)	-.604 (5.4)	.816 .92	112.2	39.42 7.58
49. Machine tools	35.60 (34.6)	12.47 (7.0)	-.354 (13.3)	.211 (2.0)	.725 .09	66.9	22.01 5.80
50. Grinding and pulver- izing	14.58 (26.0)	7.49 (7.8)	-.195 (13.5)	-.063 (1.1)	.733 .04	69.5	7.11 3.20
51. Musical instruments	18.69 (33.9)	5.24 (5.5)	-.289 (20.3)	-.254 (4.5)	.902 .08	230.1	6.45 5.19
52. Sewing and embroidery	12.99 (20.8)	4.57 (4.3)	-.169 (10.5)	.044 (.7)	.700 .07	59.3	5.90 3.37
56. Upholstery and saddlery	3.16 (26.2)	.84 (4.0)	-.045 (14.4)	.032 (2.6)	.828 .15	121.2	1.25 .86
58. Presses	4.02 (25.2)	1.75 (6.4)	-.057 (13.8)	.102 (6.2)	.723 .11	66.4	1.99 .90
59. Pumps	9.46 (26.5)	3.67 (6.0)	-.095 (10.3)	.121 (3.3)	.581 .10	35.7	6.13 1.63
60. Hydraulics and pneumatics	2.76 (16.6)	.65 (2.3)	-.041 (9.5)	.214 (12.5)	.777 .16	87.9	1.59 1.04
64. Distribution of alcoholic liquors	27.63 (43.7)	6.07 (5.6)	-.337 (20.7)	.174 (2.7)	.917 .09	278.6	12.92 6.49
73. Ropes	.86 (16.2)	.22 (2.4)	-.010 (7.2)	.021 (3.9)	.421 .10	19.2	.50 .21
76. Spinning	11.72 (30.4)	6.53 (9.9)	-.133 (13.3)	.024 (.6)	.710 .09	62.2	6.98 2.12
83. Measurement of time	7.89 (20.5)	3.99 (6.0)	-.097 (9.8)	.036 (.9)	.572 .06	34.4	4.26 1.74
85. Water purification etc.	16.56 (42.2)	4.35 (6.4)	-.199 (19.7)	.230 (7.4)	.861 .15	156.2	8.76 3.11
86. Weaving	16.18 (35.0)	6.09 (7.7)	-.224 (18.8)	.127 (2.7)	.868 .07	165.3	7.05 3.76
89. Sugar and starch industry	13.22 (22.0)	6.03 (5.8)	-.238 (15.3)	.206 (3.3)	.805 .05	104.1	1.78 3.63

Table 6  
(continued)

Class	Con- stant	Dummy 53	Time trend	Change in time trend in 1953	R <sup>2</sup> DW	F-Sta- tistics	MV SD
<u>Group 3c - (Dummy 53- significant, time trend - and change +)</u>							
14. Machines or engines in general	16.92 (18.8)	-3.12 (2.0)	-.176 (7.6)	.499 (5.4)	.684 .06	55.0	8.76 4.74
<u>Group 3d + (Dummy 53+ significant, time trend and change -)</u>							
3. Wearing apparel	16.96 (28.8)	1.89 (1.9)	-.121 (8.0)	-.257 (4.2)	.836 .17	128.5	10.52 4.30
11. Bookbinding	7.01 (25.6)	1.32 (2.8)	-.033 (4.7)	-.111 (3.9)	.603 .09	39.0	5.35 1.28
27. Fans	5.49 (44.0)	2.80 (13.0)	-.047 (14.6)	-.036 (2.8)	.774 .23	86.4	3.80 .77
34. Furniture	51.60 (47.0)	8.56 (4.5)	-.403 (14.2)	-.117 (1.0)	.870 .21	168.4	33.32 9.01
36. Heating, ventilation, hot water supply	16.81 (30.6)	2.58 (2.7)	-.106 (7.5)	-.055 (1.0)	.645 .22	46.5	12.02 2.73
38. Wood working	14.91 (48.1)	6.32 (10.6)	-.158 (17.7)	-.173 (4.9)	.894 .10	211.1	8.18 3.13
70. Writing and drawing appliances	14.62 (23.8)	3.29 (3.1)	-.149 (9.4)	-.080 (1.3)	.759 .10	79.9	7.77 3.70
80. Clay articles etc.	19.73 (34.0)	4.17 (4.2)	-.110 (7.3)	-.048 (.8)	.522 .10	28.3	15.22 2.48
82. Drying	6.85 (53.4)	2.11 (9.6)	-.052 (15.7)	-.024 (1.8)	.827 .29	120.4	4.76 .91
<u>Group 3d - (Dummy 53- significant, time trend and change -)</u>							
28. Tanning&treatm.of skins &hides,leather indust.	2.94 (23.2)	-.95 (4.4)	-.006 (1.9)	-.031 (2.4)	.804 .12	103.8	2.24 .85
<u>Group 4a (Dummy 53 not significant, time trend and change +)</u>							
12. Chemical processes	11.91 (6.8)	-1.02 (.3)	.552 (12.3)	1.526 (8.5)	.952 .14	500.7	44.61 23.59
<u>Group 4b (Dummy 53 not significant, time trend + and change -)</u>							
1. Preparation of ores	2.01 (22.5)	-.022 (.1)	.0011 (4.7)	-.092 (10.0)	.683 .31	54.8	2.24 .47
23. Oils and fats	4.84 (25.7)	-.099 (.3)	.022 (4.6)	-.035 (1.8)	.346 .25	14.2	5.82 .69
35. Lifting gear	7.32 (17.5)	1.01 (1.4)	.008 (.8)	-.088 (2.1)	.042 .13	2.1	7.75 1.15
61. Life-saving and fire-fighting	3.49 (11.6)	-.63 (1.2)	.002 (.3)	-.086 (2.8)	.399 .12	17.6	3.13 1.15
66. Butchering and meat treatment	2.16 (14.3)	-.15 (.6)	.0002 (.1)	-.046 (3.0)	.358 .16	15.0	1.97 .56
87. Tools and implements	4.17 (12.5)	-.13 (.2)	.003 (.4)	-.056 (1.6)	.071 .11	2.9	4.10 1.02

Table 6  
(continued)

Class	Con- stant	Dummy 53	Time trend	Change in time trend in 1953	R <sup>2</sup> DW	F-Sta- tistics	MV SD
<u>Group 4c</u> (Dummy 53 not significant, time trend - and change +)							
4. Light.thru fuels & pre-heating torches	23.00 (22.0)	-.96 (.5)	-.214 (7.9)	.067 (.6)	.783 .07	91.2	12.13 6.64
19. Construct.of roads, railways & bridges	10.15 (22.2)	.79 (1.0)	-.056 (4.8)	.085 (1.8)	.296 .11	11.5	7.82 1.61
40. Metallurgy other than of iron	5.84 (18.4)	.79 (1.4)	-.011 (1.3)	.069 (2.1)	.213 .09	7.8	5.74 1.06
44. Haberdashery etc.	18.31 (15.3)	.05 (.0)	-.176 (5.7)	.125 (1.0)	.580 .10	35.5	9.85 5.44
55. Product. of cellulose, paper and board	7.91 (27.1)	.60 (1.2)	-.049 (6.6)	.027 (.9)	.567 .12	33.8	5.68 1.31
68. Articles of the lock-smithing trade	18.86 22.3	-1.22 (.8)	-.120 (5.5)	.105 (1.2)	.623 .16	42.3	12.81 4.07
78. Explosives	5.01 (14.1)	-.86 (1.4)	-.034 (3.7)	.038 (1.0)	.516 .22	27.6	3.16 1.51
<u>Group 4d</u> (Dummy 53 not significant, time trend - and change -)							
20. Railway transport	39.68 (26.3)	-3.80 (1.5)	-.291 (7.5)	-.054 (.4)	.827 .10	120.8	23.69 10.72
33. Hand and travelling articles	12.14 (21.1)	1.10 (1.1)	-.082 (5.6)	-.125 (2.1)	.677 .07	53.4	7.87 2.99
45. Agriculture	34.5 (32.7)	.45 (.2)	-.082 (3.0)	-.441 (4.1)	.680 .12	54.0	29.00 5.50
69. Cutting tools	4.45 (13.3)	.27 (.5)	-.031 (3.6)	-.021 (.6)	.418 .10	18.9	2.87 1.30

The negative trend amounts to 0.121 per thousand a year. After the Second World War the decline in this class's share increases by a further 0.257 per thousand a year. The overall negative trend after the Second World War thus amounts to 0.378 per thousand.

The figures in brackets below the values of the coefficients of the function are used to determine the statistical reliability of the estimated coefficient. The higher these figures are, the clearer - and with fewer deviations - the calculated value is in line with the actual trend. The significance level for the calculated values is around 1.6-; this means that the values with t-statistics below 1.6 can no longer be regarded as significant. This can be illustrated by the example of Class 75 "Sculpture". Of all the coefficients calculated only the constant is significant. This means that practically throughout the period the trend fluctuated at random around the value of the constant 4.31, with no systematic shift in the level or trend pattern. The value of the coefficient of determination R<sup>2</sup> shows how the whole function is in line with the trend. The F-statistics in the penultimate column fulfil a similar purpose. The higher these values are, the better the trend function matches the actual trend. The Durbin-Watson coefficient - denoted by DW - is a statistical measure of the autocorrelation of the deviations from the estimated trend. As mentioned above, MV represents the mean value of the relevant patent class's shares of total applications over the whole period. The standard deviation (SD) measures the dispersion around this mean value.

In order to make it easier to analyse the calculated time trends and coefficients of shift, the patent classes were divided into a number of groups according to the values calculated :

*Group 1* comprises only one class in which of all the four coefficients only the constant is significant.

*Group 2* comprises those classes in which both the constant and the dummy 53 were significant. It thus covers those cases in which there was an upward or downward shift in level after the Second World War but in which there were no significant time trends or changes therein. It includes, for example, Classes 15 "Printing", 65 "Ships", etc.

*Group 3* comprises those classes in which, in addition to the significant dummy 53 (i.e. a significant shift in level after the Second World War), significant trends or changes thereof were also calculated. This group is then subdivided into *Group 3a+* in which both the time trend and the change thereof were positive, as in the case of Classes 39 "Working of plastic masses", 42 "Instruments", 48 "Working and treatment of metals other than by mechanical means" and 81 "Transport".

*Group 3a-* is the same in so far as both the time trend and the change thereof were positive. However, in contrast with *Group 3a+* the dummy 53 is negative in *Group 3a-*. This means that the level fell after the Second World War. This group includes, for example, Classes 57 "Photography, cinematography and sound film" and 84 "Hydraulic engineering and foundations". *Group 3b+* comprises those classes in which the dummy 53 was positive but in which the initially positive time trend became negative after 1953. It comprises two patent classes : Nos 5 "Mining" and 18 "Metallurgy of iron". On the other hand, *Group 3b-* comprises those classes in which the dummy was negative, reflecting a downward shift in level after the Second World War. As in the case of *Group 3b+*, the classes in *Group 3b-* show a positive time trend and a negative change. This group comprises 18 patent classes, i.e. a fifth of the total number. *Group 3c+* comprises all classes in which the dummy 53 was positive, the time trend negative and the change therein positive, e.g. patent class 6 "Zymology". This class's initial level stood at 16.96 per thousand and rose by 5.52 per 1,000 after the Second World War. Up to the Second World War this class's share fell by 0.278 per thousand per year. After the Second World War, however, this trend moved upward by 0.361 per 1,000, giving an overall positive trend of 0.083 per 1,000 per year. A similar trend shift was also recorded in Classes 22 "Dyes", 32 "Glass", 60 "Hydraulics and pneumatics" and many others. *Group 3c+* is the largest, comprising 25 patent classes. *Group 3c-* comprises those patent classes which show a negative dummy 53, a negative time trend and a positive change. Lastly, *Groups 3d+* and *3d-* comprise those patent classes in which both the time trend and the change therein were negative. In other words, these classes' share of total patent applications fell over the whole period, this fall being particularly marked after the Second World War. The difference between *Groups 3d+* and *3d-* lies in the positive or negative value of the dummy 53, i.e. the positive or negative shift in level after the Second World War. *Group 3d+* comprises nine patent classes whose level moved upwards after the Second World War, e.g. Classes 3 "Wearing apparel", 11 "Bookbinding", 27 "Fans", etc. *Group 3d-* comprises only one patent class, namely No 28 "Tanning and treatment of skins and hides, leather industry".

Finally, *Group 4* comprises those classes in which the dummy 53 was not significant, i.e. which showed no structural change such as a shift in level after the Second World War.



This group is divided into subgroups 4a, 4b, 4c and 4d on the basis of the four possible combinations of the positive and negative trends and their changes all along. In *Group 4a* both the trend and the change therein are positive. It thus comprises classes which showed a positive growth even before the Second World War, becoming even more marked in the post-war period. It covers patent class 12 "Chemical processes". *Group 4b* comprises those patent classes which showed a positive trend before the Second World War and a negative one afterwards. This is the case, for example, in Class 1 "Preparation of ores", in which the positive trend before the Second World War turned into a negative one in the post-war period. *Group 4c* comprises the patent classes in which the time trend was negative before the Second World War and subsequently moved upwards, i.e. showed a positive change. It must be emphasized, however, that in all cases in this Group 4c (positive) changes in the time trend are either very slight or even insignificant. Lastly, *Group 4d* comprises the patent classes in which both the time trend and the change therein were negative after the Second World War, e.g. Class 45 "Agriculture". In this case, the relatively slight downward trend of 0.082 per 1,000 per year increased by 0.441 after the Second World War, giving a total of 0.523.

*C. Differentiation between long-term, short-term and structural influences on trends in patent applications*

Looking at trends in the total number of patent applications in Germany over the last 100 years, it is immediately apparent that the shape of the curve was affected by a number of important occurrences.

The number of patent applications fell during the two world wars. In the last five years before the First World War the total number of patent applications was approximately 230,000. During the five war years from 1914 - 1918 this figure fell to approximately 137,000, i.e. 59.5 %. The influence of the Second World War on trends in patent applications does not seem to have been so great, but this may be due to the fact that there are no data for the last two years of the war, namely 1944 and 1945.

Comparing first of all the five war years 1939 - 1943 for which the data are available with the last five pre-war years, the following picture is obtained :

In the period from 1934 to 1938, approximately 276,000 patent applications were filed, compared with around 244,000, i.e. 88.5 % in the five war years. However, it is more correct to compare the number of war time patent applications not with the immediate pre-war years but with the last years before the economic crisis in the 1930s. In these years (1926 - 1930) a total of around 355,000 patent applications were filed. In comparison with this basic period, the number of patent applications in the war years fell to 68.9 %, i.e. a somewhat smaller drop than during the First World War. It is quite possible, however, that the data for the last two war years would have reduced its ratio still further. In any event, it can be stated in conclusion that the declines associated with the war years reduced the number of patent applications to approximately two thirds.

The great world economic crisis in the 1930s caused a decline of similar proportions in the number of patent applications. The largest number (78,400) was filed in the first year of the crisis, i.e. 1930. As a rule, there is always a lag of this kind between the trend in patent applications and the general economic cycle. Taking the number of gainfully active persons as an indicator of cyclical trends, the peak of 32,531,000 comes as early as 1928, the bottom of the curve being reached during the crisis period in 1932 with 26,113,000 persons, i.e. 80.3 % of the peak. Taking the gross national product as the indicator of cyclical trends, the pre-war peak moves to 1929, while the bottom of the curve is again reached in 1932, when the gross national product was 76.5 % of the 1929 figure. As in the case of the greatest number of patent applications, there is again a time lag before the minimum number is reached. The low point came in 1934 with approximately 53,000 patent applications, i.e. 67.4 % of the 1930 peak. These figures show clearly that, quite apart from the time lag with respect to the general economic cycle, the downward swing in the number of patent applications is greater than that in the economic indicators.

The second major downturn in the trend of patent applications came in the 1970s and 1980s. The peak was reached in 1972 with around 67,000 patent applications. Our series go as far as 1981, when 46,579 patent applications, i.e. 69.0 % of the figure, were filed.

Another important factor which clearly affected the shape of the curve was the change of the German territory. After the Second World War our series no longer refer to Germany as a whole but only to the Federal Republic. This pushes the whole curve downwards in the post-war period. An attempt has already been made before to give an approximate quantitative estimate of the influence of this factor.

It is clear that merely looking at the figures can identify only one or two important connections. It requires a more detailed statistical analysis to clarify other important questions. In particular, various influences can be differentiated from one another only on the basis of statistical analysis of disaggregated data. This involves primarily the following questions :

Assuming that patent applications reflect the production of new technological know-how, is there a causal relation between the latter and the general economic cycle? If so, is it a crisis-triggering cause which at the same time also ensures that the crisis will be overcome, or vice versa? Is the production of new technological know-how to be regarded rather as a consequence of cyclical trends or is the trend in patent applications not to be regarded rather as a consequence of longer-term trends which go beyond the temporal bounds of the general economic cycle? Are the trends in patent applications not linked rather to the longer waves of general economic trends, known as Kondratieff waves?

In order to obtain an answer to these questions, the trends in patent applications with time would have to be corrected for the short-term influence. In addition, the time series would also have to be corrected for the effects of the territorial change after the Second World War. Only as part of such a statistical analysis of the time series would it be possible to single out the long-term trends in the production of technological know-how.

Disaggregation of the data is equally necessary. A number of hypotheses relating to homogeneous areas of technology have already been put forward and tested here. These trends were regarded as exhaustion trends and also statistically tested from this angle. It emerged in fact that a time sequence of different areas of technology is characteristic of the development of the whole technology. It also transpired that the whole of the technological development in different periods is shaped by different areas of technology. These areas alternate in the afore-mentioned sequence. The question is in what way the trends in the various areas differ. One possibility is that the general economic trends relate only to the areas of technology where the potential has been exhausted and that the other - expanding - areas are not affected at all by the general economic trends. In other words, the expanding areas grow equally quickly, i.e. irrespective of the phase in the general economic cycle, both in the period of crisis and in the boom period. The other hypothesis would be as follows : all areas of technology are affected by general economic trends, perhaps even to the same extent, with the difference that the long-term trends in these sectors differ from one another. The answer to this question was obtained from the statistical analysis whose results are shown in Table 8 (see page 97).

In this table the long-term economic and structural influences on trends in patent applications are shown separately from one another.

For this purpose, all the 89 patent classes were grouped together into five major sectors. The criterion applied was that of the period in which each patent class shows the greatest growth. This period was determined by the results of the above analysis of trends in patent classes based on the estimated logistic curve.

The patent classes were divided into groups according to whether the turning point in the logistic curve came after 1971, between 1960 and 1970, between 1949 and 1959, between 1929 and 1948 and, lastly, before 1929. The patent classes included in each aggregate are shown in the footnotes to the table. The first group comprises such dynamic classes as Nos 12 "Chemical processes", 39 "Working of plastic masses" and 58 "Presses", the latter showing an upward trend again in recent years, i.e. in the 1970s.

The second group comprises the classes which reached the estimated peak annual number of applications between 1960 and 1970. It includes important classes concerned with automation, e.g. Nos 42 "Instruments", 47 "Engineering elements or units", etc., and also Class 48 "Working and treatment of metals other than by mechanical means".

The third group comprises the classes which reached their peak annual number of patent applications between 1949 and 1959. It includes such classes as 18 "Metallurgy of iron", 19 "Construction of roads, railways and bridges", 21 (one of the most dynamic of all) "Electrical engineering", 22 "Dyes", 40 "Metallurgy other than of iron", 45 "Agriculture", 49 "Machine tools", 57 "Photography, cinematography and sound film" and 83 "Measurement of time".

The fourth group comprises the classes which reached their peak annual number of patent applications between 1929 and 1948. It covers 27 patent classes, including : 1 "Preparation of ores", 11 "Bookbinding", 15

"Printing", 30 "Medical science", 34 "Furniture", 36 "Heating", 46 "Combustion engines", 54 "Working of paper and board", 55 "Production of cellulose, paper and board", 63 "Trackless vehicles", 79 "Tobacco", 80 "Clay articles", 86 "Weaving", 87 "Tools and implements".

The fifth group comprises the classes which reached their peak before 1929. These are the classes which to date have exhausted their technological development potential the most. This group includes the following classes : 2 "Baking", 3 "Wearing apparel", 4 "Lighting through fuels", 6 "Zymology", 9 "Brushware", 10 "Fuels", 13 "Steam boilers", 14 "Machines or engines in general", 20 "Railway transport", 24 "Furnaces etc.", 26 "Production of gases", 28 "Tanning", 41 "Headwear", 44 "Haberdashery", 51 "Musical instruments", 52 "Sewing and embroidering", 56 "Upholstery and saddlery", 64 "Distribution of alcoholic liquors", 65 "Ships", 68 "Articles of the locksmithing trade", 71 "Footwear", 89 "Sugar and starch industry".

The results of the disaggregation of patent applications and of the comparison of trends in patent applications with economic trends can be illustrated by means of the two diagrams below (Figures 1 and 2).

Figure 1

Trends in gross national product (G), number of gainfully active persons (E), population (B) and patent applications (T) in Germany or the Federal Republic of Germany in the period 1877 - 1979 (semi-logarithmic representation)

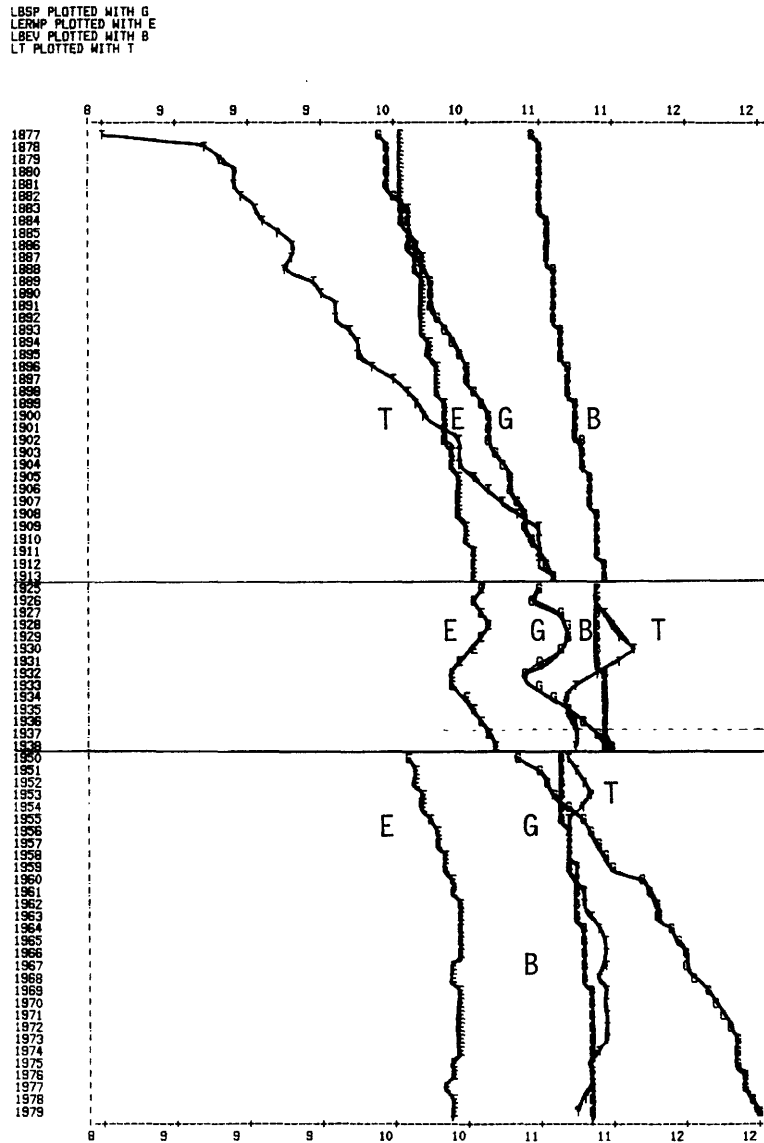
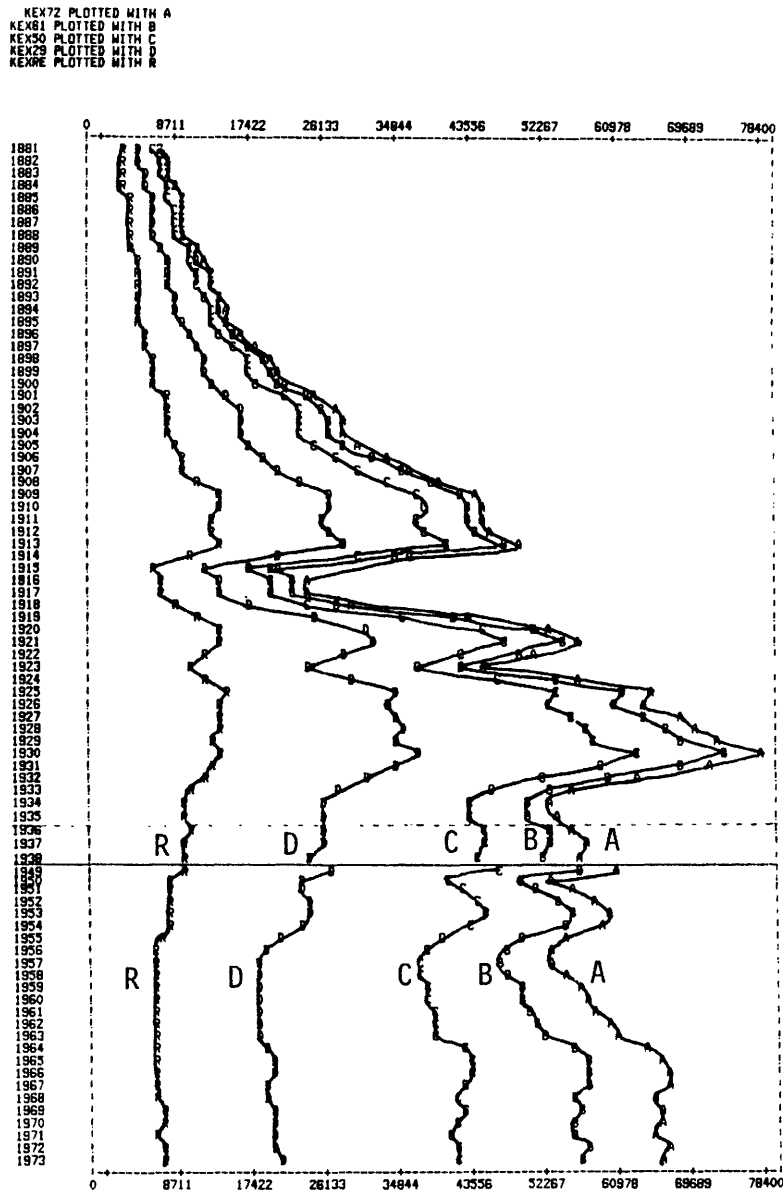

Figure 2

Trends in the groups of patent applications with differing growth rates in Germany or in the Federal Republic of Germany in the period 1881 - 1973



- A = Total (= Group 72 + Group 61 + Group 50 + Group 29 + Remainder Group)
- B = Group 61 + Group 50 + Group 29 + Remainder Group
- C = Group 50 + Group 29 + Remainder Group
- D = Group 29 + Remainder Group
- R = Remainder Group

*Figure 1* compares the trends in the general economic and demographic variables with trends in the total number of patent applications. The population variable shows above all the reduction of the population of the Federal Republic of Germany compared with pre-war Germany. This change is also reflected in the other variables shown in this diagram. The variables 'gainfully active persons' and 'gross national product' show above all the long-term trends and short-term fluctuations in economic activity.

Also of note here are the differing relationships between the production of technological know-how and general economic trends before and after the Second World War. Whereas before the war the total number of patent applications went up at a much faster rate than the number of gainfully active persons and gross national product, things changed after the war. Gross national product grew much quicker than the number of patent applications and trends in the number of gainfully active persons ran more or less parallel with trends in the number of patent applications.

*Figure 2* documents and illustrates the trends in individual groups of patent applications. In addition to the total number of patent applications it also shows individual groups of applications, the composition of which has been given before. This diagram illustrates the processes quantified in Table 8.

In the three distinct periods shown in this diagram, there was a clear shift in the ranking order of the various groups of patent applications. In the first period - before the First World War - Group R (Remainder) had the biggest share. In the second period - between the World Wars - this group dropped to third place. In the first period Group 29 was more or less at the same level as Group R, i.e. in first place, but in the second period it is in second place and in the third period - after the Second World War - it dropped to third place.

Group 61 was in next to last, i.e. fourth, place in the first period, stayed there in the second period but rose to second place in the third period.

The development of group 72 is also very impressive. At the beginning of the whole time series its share was very small, but it showed the fastest growth and stood in fourth place after the Second World War. Although a lot of important information about trends in patent applications and their causes can be obtained directly by looking at the diagrams, the differentiation and quantification of various factors was possible only on the basis of a more detailed statistical analysis.

#### *Differentiation between endogenous and exogenous factors*

The starting point for the qualitative and quantitative differentiation of various factors influencing trends in patent applications was the distinction between endogenous and exogenous factors from the point of view of science and research. Our hypothesis about research trends in individual areas of technology, above all the hypothesis of the exhaustion of research potential, played an important part in identifying endogenous factors.

The exogenous influences of trends in patent applications were sought primarily in the relationship between technology and science on the one hand and economic trends on the other. It transpired that the number of patent applications as a whole and in individual classes is dependent mainly on the level of economic activity and trends therein. This factor has a long-term effect on trends, in spans which are much longer than the duration of the economic cycle. On the other hand, patent applications and trends therein are subject to the influence of the economic cycle. It became apparent that general economic trends affect trends in patent applications with a certain time lag.

The structural influences on trends in patent applications can be regarded as a sort of combination of the exogenous and endogenous factors. These influences are linked to the fact that the states of exhaustion do not occur at the same time in all areas of technology but at intervals. Moreover, when the technological potential of a particular principle has been exhausted, leading to stagnation of developments in the relevant patent class, a new principle is discovered and gradually implemented through a whole series of inventions. In this way the relevant patent class is given fresh impetus. The discovery of completely new areas of technology has a similar effect. The trends in the total number of patent applications are then influenced by structural shifts of this kind between and within individual areas of technology.

The exhaustion of the technological development potential in the individual areas often spans several decades or even centuries. Since the trend in patent applications represents the production of new technological know-how, it will sooner or later be reflected in economic trends. It can also be held responsible for the long waves of economic trends. In this connection, our analysis shows that patent applications were on an upward trend until about the beginning of the 1950s; since that time, however, the trend has been negative, except in the case of one or two expanding patent classes. It is quite within the bounds of possibility that the economic crisis in the 1970s, which was caused directly by other factors, was made more serious, more acute and longer by the negative trend in the production of technological know-how over the previous 20 years or so.

Of various economic variables whose connection with the trend in patent applications was studied, the number of gainfully active persons has proved to be the best explanatory factor. It is used to represent the long-term trend in the level of economic activity.

Using the data available, we were able to examine trends in the number of gainfully active persons in Germany since 1882 and use them as an explanatory variable for the number of patent applications. Up to 1950, the rate of increase of the number of gainfully active persons amounted to approximately 0.8 % a year, while since 1950 this rate has risen somewhat to around 1.1 % a year. The statistical analysis of trends in the number of gainfully active persons before and after the war showed that the number in the Federal Republic of Germany was approximately two thirds that of the pre-war level. Table 7 shows the results of the estimated time trend in the number of gainfully active persons.

Table 8 shows the results of the statistical differentiation of various factors affecting trends in patent applications.



The columns show quantitative factors based on various explanatory variables. The lines show various groups of patent classes. These groups comprise the patent classes which reached their maximum rate of increase in different periods. This classification of the patent classes is based on the analysis using the logistic curve. On the basis of the estimate of this curve, it was possible to determine for each class the time at which the growth rate began to slow down. In this way, a distinction was made between the classes which reached their peak in the 1970s, the 1960s, the 1950s, before the war and before 1929.

The column 'Trend in the number of gainfully active persons' shows the long-term effects of economic trends on the production of technological know-how.

The coefficients of the individual equations represent the elasticities of trends in patent applications in relation to the trend in the number of gainfully active persons. The elasticities calculated show by what percentage patent applications increase when the number of gainfully active persons goes up by 1 %. The elasticity of the growth in patent applications as a whole was calculated at 2.23; this means that for every increase by 1 % of the number of gainfully active persons the number of patent applications goes up by 2.23 %. The elasticity with which the number of patent applications affects the rate of increase of the number of gainfully active persons does not differ greatly from one group of patent classes to another, being around 2 % in all cases.

TABLE 7

Time trend in the number of gainfully active persons in Germany (or the Federal Republic of Germany) in the periods 1882-1913, 1919-1935 and 1952-1973 (exponential spline function)

Constant of the function	Time trend up to 1950	Change in time trend from 1950 onwards	Change in the constant of the function from 1950 onwards	$\bar{R}^2$ adjusted	F-Statistics	D W
9.93 (492.4)	.0080 (14.1)	.0030 (1.3)	-.498 (12.2)	.761	75	.15

TABLE 8

Trends in patent applications in the periods 1883-1913, 1920-1935 and 1953-1973 due to cyclical and longer-term structural factors (t-statistics in brackets)

Patent classes with estimated peak in the years	Con-stant	Time trend before 1950	Change in time trend from 1950 onwards	Trend in the number of gain-fully active persons	Cyclical trend in the num-ber of gainfully active persons	R <sup>2</sup> adjusted	F-statistics	D W
1. After 1971	-14.0 (2.6)	.0442 (24.6)	-.0282 (4.3)	1.92 (7.5)	3.34 (8.9)	.978	753	.42
2. 1960-1970	-11.7 (6.9)	.0306 (25.9)	-.0269 (6.3)	1.85 (11.0)	2.62 (10.6)	.980	839	.54
3. 1949-1959	-13.6 (10.7)	.0307 (34.4)	-.0475 (14.6)	2.12 (16.8)	1.94 (10.5)	.987	1230	.58
4. 1929-1948	-17.8 (10.0)	.0225 (18.0)	-.0552 (12.1)	2.57 (14.5)	2.29 (8.8)	.959	389	.41
5. before 1929	-19.0 (9.3)	.0079 (5.5)	-.0414 (7.9)	2.72 (13.4)	2.69 (9.0)	.897	147	.42
Total of all patent classes	-13.1 (9.1)	.0240 (23.5)	-.0364 (10.4)	2.23 (15.4)	2.38 (11.2)	.976	683	.52

1. Classes : 12, 39, 58

2. Classes : 31, 32, 37, 42, 47, 48, 81, 84

3. Classes : 5, 7, 8, 17, 18, 19, 21, 22, 23, 27, 29, 35, 40, 45, 49, 50, 57, 59, 73, 75, 76, 83

4. Classes: 1, 11, 15, 16, 25, 30, 33, 34, 36, 38, 43, 46, 53, 54, 55, 61, 63, 66, 67, 69, 74, 79, 80, 82, 85, 86, 87

5. Classes: 2, 3, 4, 6, 9, 10, 13, 14, 20, 24, 26, 28, 41, 44, 51, 52, 56, 60, 62, 64, 65, 68, 70, 71, 72, 77, 78, 88, 89

The statistical analysis also made it possible to differentiate between the effects of short- and long-term economic trends. It emerged that all the groups of patent classes react very strongly to cyclical trends with a time lag of one year. This applied not only to the patent classes which are losing ground but also to those which are expanding. The long-term growth of the patent classes is thus endogenous and dependent on trends in science and research and cannot be attributed directly to long- and short-term (cyclical) economic trends.

The endogenous factors affecting trends in patent applications are reflected in the time trend in the number of patent applications. This time trend was calculated for the periods before and after 1950, since it was precisely at this time that there was a burning-point in the trend. The time trend up to 1950 is shown in Table 8, while the time trend after 1950 is calculated as the algebraic sum of the time trend before 1950 and the change in the time trend from 1950 onwards. The growth rate for the total number of patent applications before 1950 was 2.40 % per year, compared with a negative growth rate of 1.44 % after 1950. Only the first two groups of patent classes maintained positive growth rates after 1950. The first group grew by 4.42 % a year before 1950 and by 1.60 % after 1950. The second group grew by 3.06 % a year before 1950 but only very slowly (0.37 % a year) after 1950.

The third group grew by 3.07 % a year before the war but showed a decline of 1.68 % a year after the war. The fourth group grew by 2.25 % a year before the war but fell by 3.27 % a year after the war. Lastly, the fifth group grew by an average of 0.79 % a year before the war but fell by 3.35 % a year after the war.

## CONCLUSIONS



## CONCLUSIONS

This study sets out to analyse and interpret technical development on the basis of the German patent statistics, a veritable mine of information for the historian interested in technical and technological developments in Germany and the rest of the world over the past 100 years. Statistics of patent applications in time series are available from 1877, the year in which the national patent legislation was enacted (the "Reichspatentgesetz") and the National Patent Office set up (the "Reichspatentamt"). The reason why the statistical material at our disposal is so extremely valuable is because the time series exist in a relatively detailed form, classified along the lines of the structure of the economy itself. One important aspect underlying the planning and conduct of this study was the fact that this wealth of material has so far hardly been drawn on at all by economic, technological and historical researchers.

The study was carried out in two stages, the first stage comprising the compilation and storage of the data published year by year by the Patent Office. This provided the groundwork for a subsequent detailed statistical analysis of the data, the first stage being concluded by the publication of the data and diagrams. Experience has shown that there is a great deal of information value to be derived simply from printing the data series in graph form, showing at a glance that trends in the various patent classes depend on certain specific endogenous and exogenous factors.

The second stage comprised the statistical and substantive analysis of the trends brought out by the time series of the various classes of patent application. It was thus possible to interpret trends in the various classes and to formulate and verify a number of general hypotheses regarding technological developments. The results of the second stage of the study are presented in this report. The following summary of results refers to the aims of the study outlined in the introduction. The first aim was to plot trends in technological development by reference to trends in patent applications. This was possible for 89 patent classes from 1881 to 1973 and for a third of the time series for years after 1973.

Closer inspection of the information which can be derived from studying trends in patent applications has shown that these trends are above all a reflection of the productive application of new technological know-how.

The number of patents applied for reflects the amount of research going on and, in this respect, a comparison can be made with trends in patent applications and similar trends in research expenditure or research staff. One of the main advantages of the time series of patent applications is that neither the same kind of detailed information nor anything like the same kind of time series is available to research expenditure.

The number of patents applied for was therefore, taken to be representative of the results of research work, although it must of course be borne in mind that merely counting the number of applications takes no account of their technical or economic importance. The comparisons with trends showed, however, that the pattern of patent applications (from the point of view of importance) can be expected to remain fairly stable.

The time series were also taken as a reflection of the technical potential available for the purposes of improving production (both the production methods and the products themselves). The way in which this potential is utilized usually depends on a number of factors outside the field of research and science proper. No data are available, however, as to how the potential is utilized in production or business terms. The same kind of detailed and long time series does not exist to reflect trends in production, manpower and productivity. However, production in the meaning of the utilization of technological potential is reflected in the level of research activity and the number of patents applied for. To some extent, then, the trend in patent applications could reasonably be taken as a reflection of the utilization of technological potential.

Generally speaking, the validity of using time series of patent applications to reflect the production of technological know-how, as described in the relevant literature, has been found to accord with the results of this study. Empirical analysis of the time series confirmed that trends in patent applications are subject both to endogenous (i.e. due to scientific developments) and to exogenous (non-scientific) factors. A glance at the diagrams alone showed the effects of one or two factors of this kind, such as wars, economic crises and the general economic cycle. The endogenous trends too were brought out clearly in the time series. Trends in the various patent classes evidently vary according to characteristic patterns, and the major causes too can be clearly identified. However, it was also apparent that the trends in the various classes are of a systematic nature and this is clearly reflected in all the series despite any amount of random fluctuations. The differences between the classes are indicative of specific situations and conditions and are, as a rule, easy to interpret.

By way of a starting point for the study, a number of hypotheses were formulated and were then further developed and tested in the course of the study. Some of these hypotheses were derived from the available literature which, however, gives only vague indications of a possible theory of technological development. Some of them had been developed and used in earlier work undertaken by the author.

The main hypotheses are set out in summarized form below, all of them relating to trends in patent applications.

1. The trend in patent applications is regarded as a reflection of trends in the production of technological know-how.
2. The patent applications anticipate technological progress at the production stage.
3. The trend in patent applications, therefore, depends on the allocation of research funds, a factor which is itself dependent on the economic situation.
4. The trend in patent applications is on the one hand a reflection of the pressure for the solution of technical and scientific problems and the full utilization of research facilities in scientific circles and, on the other hand, a reflection of the business community's interest in, and need for, rationalization, cost saving and market expansion, creation and dominance.
5. The trend in patent applications is seen as being a function of the full utilization of research facilities in certain areas of technology, and it is assumed that this follows a logistic pattern.
6. The trend in patent applications is regarded as dependent on technological breakthroughs in the various classes, due in particular to the full utilization of research facilities and the pressure of business interests.
7. The trend in applications for patents in the various classes is seen as being dependent on developments in other classes. Two factors are seen here as being of major importance, namely competition in the various areas of technology and the way in which developments in one area of technology can be aided by developments in another such area.

The above hypotheses have proved to be useful in analysing and interpreting trends in the various statistical series of patent applications. They have undergone further refinement and their validity has now been confirmed. The study itself features a number of examples of concrete developments reflecting the above patterns.

For the purpose of statistical analysis of the time series of patent applications, two main instruments were used, namely the logistic function and the trend function with spline variables. By using these functions, it was possible to concentrate the mass of statistical data and to reduce it to a few comparable parameters, thus facilitating comparisons with trends in the various classes. This comparison was also extended to trends in patent applications in the USA, although trends in Germany alone were regarded as highly representative of world trends, this assumption being based on the role of the German economy in world business and trade and the special motivational features of patent applications abroad and being validated by a comparison with trends in the USA. Experience has also shown that, by comparing international trends in patent applications, it is possible to identify technological gaps and leads from country to country.



The statistical and substantive study of trends in specific classes of patent applications made it possible to trace developments in old and new areas of technology over the past 100 years. It was thus also possible to identify developments in the structure of production and of technological know-how and to ascertain the dominant areas of technology in various periods of economic growth.

The study showed that the trend in patent applications is closely linked to the economic situation and that the production of technological know-how (as reflected in the patent applications) has a longer-term effect on economic developments. Using statistical analysis techniques, we have managed to identify long-term trends and medium-term fluctuations in the production of technological know-how and to express these specific factors in quantitative terms.

MARTIN STEIB IN HAMBURG.

Schieberglocken-Verschluss an Schirmen.

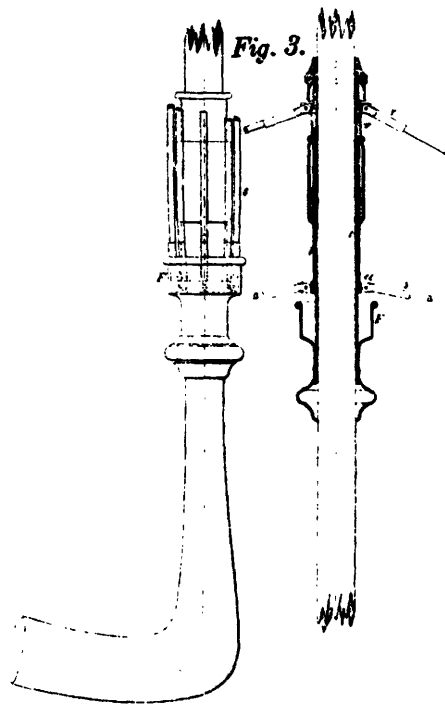
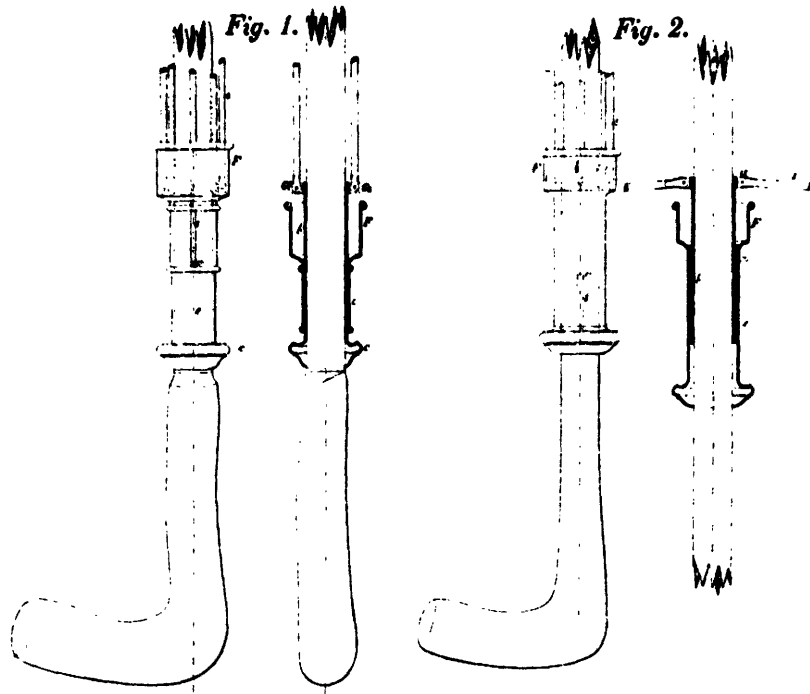

Zu der Patentschrift

№ 184.

PHOTOGR. DRUCK DER KÖNIGL. PREUSS. STAATSDRUCKEREI.

R. MATTCHE IN BERLIN.

**Stiefelknecht.**

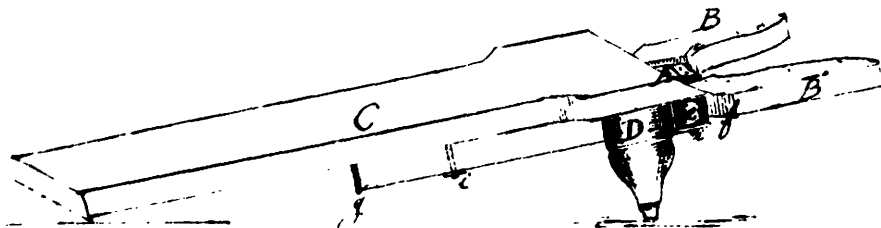
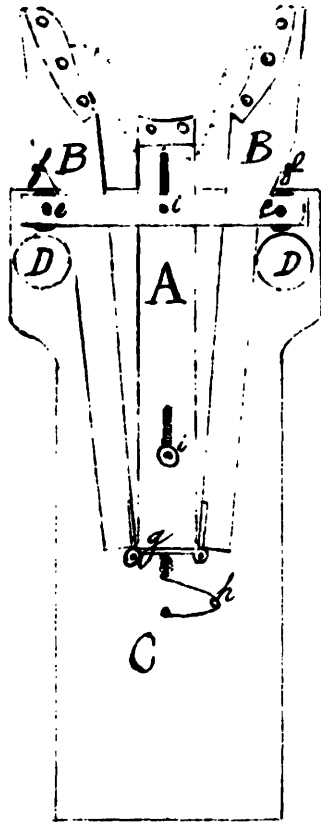

Zu der Patentschrift

**№ 8.**

PHOTOGR. DRUCK DER KÖNIGL. PREUSS. STAATSDRUCKEREI

LITERATURE  
AND  
REFERENCES



## LITERATURE AND REFERENCES

Studies of trends in patent applications - especially in Germany - are relatively few and far between. The acknowledged world authority on this subject is Jacob Schmookler, who died in 1967 at the age of 49, i.e. in the middle of his productive scientific career. A bibliography of his works and other works of the same ilk in the years 1966 to 1970 is given in the book : Jacob Schmookler, Patents, Invention and Economic Change, edited by Zvi Griliches and Leonid Hurwicz, with a foreword by Simon Kuznets.

Schmookler compiled long time series of American patent statistics and used these data in his studies. The data series which he used were not presented in the above-mentioned book until after his death. The time series cover the period from 1837 to 1957 and refer to patents granted, which in some cases were classified not according to the year of granting but according to the year of the patent application. An even more important and certainly very time-consuming rearrangement of the data originally published by the Patent Office was Schmookler's reclassification according to the Standard Industrial Classification. Whereas the classification used by the Patent Office for publishing the data is based on technological function, the Standard Industrial Classification is structured according to branches of industry. The editors of Schmookler's time series illustrate the problems with a number of examples. There is a class which covers inventions in the field of distribution of fluids. It includes both patents for the sprinkling of holy water and a patent for water pistols. Furthermore, the patent class covering the distribution of solids includes both a patent for the distribution of fertilizers and a patent for the toothpaste tube. Schmookler compiled 458 time series of US patents on the basis of his reclassification. Some of these time series have been analysed in the present study and the trends shown by them compared with trends in Germany. The German patent statistics have put us in a much more fortunate position, since they are geared much more than the American statistics to the industrial utilization of inventions and thus take much more account of the product and the branch aspects.

After Schmookler's death, a number of scientists - particularly in the United States - continued to work along the same lines. The biography edited by Griliches and Hurwicz includes the names of Comanor, Denison, Fellner, Griliches, Jorgenson, Hufbauer, Mansfield, Thomas Marschak, Mathias, Nordhaus, Scherer, Vernon and many more. Almost all of them are American authors. There are very few works of this kind in Europe or, therefore, the German-speaking area. The German patent statistics were used to some extent in the literature on economic history. The most detailed publication of the data appeared in the 1965 study edited by Walther G. Hofmann entitled "Das Wachstum der deutschen Wirtschaft seit der Mitte des 19. Jahrhunderts" (The growth of the German economy since the middle of the 19th century).

This study attempted to correlate the patent statistics in highly aggregated form with progress in productivity. In this respect, the patents data may compete with the data on research and education expenditure. The above-mentioned work said the following on this question :

*"The data on research and education expenditure show more or less in what way the training of employees and therefore the quality of the labour factor have been improved. Since better training and aid to research usually lead to a greater number of inventions and better operational and administrative organization, these facts have a direct bearing on technical and organizational progress. The number of patents granted is a further approximate yardstick of technical progress, although it says nothing about the economic effectiveness of individual patents, since the overall number includes economically important and unimportant patents."\**)

*The disaggregated time series of patent applications which appeared in this publication were not evaluated. Even the above-mentioned study is limited to analysing growth and clarifying the content of the residuals of the production function, which go under the confusing name of technical progress. The possibility of regarding and studying long-term trends in patent applications and grants as a reflection of the process of technological development itself is not considered.*

*Various documents of the Patent Office also deal with patent statistics, first and foremost being the annual publications which appeared initially in the periodical "Patentblatt" and later in the "Blatt für das Patent-, Muster- und Zeichenwesen".*

*The Patent Office did not merely publish these statistics but always added brief interpretative commentaries and remarks. The very nature of these annual publications shows, of course, that they were concerned not so much with long-term trends but above all with cross-sectional problems, i.e. the structure of patent applications and grants in the relevant year. In addition, the tendencies which became apparent in some of the most recent years were ascertained.*

---

\* ) (G. Hofmann, Grumbach, Hesse, op. cit., pp. 28-29).

Longer-term trends are dealt with in a number of publications issued to mark the jubilee of the Patent Office and the Patent Law, such as the publication brought out at the 25th anniversary of the Patent Office and the Patent Law in 1902 or the commemorative publication to mark the 75th anniversary of the German Patent Office (published in 1952 as part of the "Blatt für das Patent-, Muster- und Zeichenwesen") or lastly the commemorative publication issued in 1977 under the title "100 Jahre Patentamt". While the last two publications make valuable contributions to one or two selected areas of technology, written primarily by the technical members of the Patent Office, i.e. highly qualified experts in individual areas of technology, only the first-named publication, which was issued in 1902, gives a highly detailed analysis of the patent statistics by classes.

This publication, which has almost been forgotten even by the Patent Office, deals in exemplary fashion with the development of the time series for the whole of the patent classification up to 1900. Apart from the interest in the questions which were important for the Patent Office's current work (e.g. the number of patent applications as a measure of the work load in individual departments or the relationship between the number of patent applications and grants - this question is also dealt with here from the point of view of the participation of technically unqualified inventors, who were always attracted by published new developments) [1]\*), this publication also contains many notable conclusions, both general and specific, as, for example, on the influence of the weather on patent applications in the agricultural sector [2]. In addition, there are many references to the more general problems of technological development, such as the hypothesis of the exhaustion of innovative potential in homogeneous areas of technology [3]. Of interest is the reference to competition between different technological solutions, resources and products, e.g. the rivalry between electric and gas lighting [4]. As we know today, the end of gas lighting came in 1910 as a result of the discovery of the practical method of drawing tungsten wire. Fifty years later, an independent article entitled "The tungsten wire drawing patent" by Walter Heine (member of the German Patent Office) appeared in the Patent Office's commemorative publication. This patent was also mentioned in the paper by Klasten "Zur Entstehung und industriellen Auswirkung einiger Pionierpatente" (commemorative publication to mark the 75th anniversary of the German Patent Office, published by the German Patent Office as part of the "Blatt für Patent-, Muster- und Zeichenwesen", Munich, 1952, pp. 292-297). A connection of this kind was already established in 1902 in the analysis of subclass 21f "Electric lighting" in the Patent Office's first commemorative publication marking its 25th anniversary [5].

Interesting information on the question of the proportions of foreigners and nationals filing patent applications can be found, for example, in the chapter devoted to the textile industry [6].

It goes without saying that the results of the studies described in this publication were limited by the relatively short period covered.

---

\*) For the notes in square brackets [ ], see pp. 112 - 114.



In addition, certain limitations which, given the level of knowledge at that time, existed both in economic history and in the current analysis of the relationship between technology and the economy and also in the methodological field as regards evaluation of the time series cannot be ignored. It is just a pity that since that time the Patent Office has not used its extensive know-how and the high qualifications of its experts in the way indicated here to produce synoptical publications of this type.

[1]"Here as in many other areas it is apparent that the applicants attracted by outward successes made up only a small percentage of those granted patents."

*"The sharp decline in patents granted is primarily to the detriment of subclass 80b 'Ceramics, mortar, etc.' and is mainly attributable to the fact that a large proportion of the applications do not come from specialists. This observation is made in the description of trends in Class 80 'Clay articles, chalk, cement, etc.'." \*)*

[2] One or two examples : In the discussion of trends in Class 45 "Agriculture", the authors write :

*"In Class 45 the failure of the harvest in a particular year has an often clearly discernible influence on the main direction in which inventions move. Thus, wet years focused attention on driers for cereals, while richer harvests, which made the lack not only of workers but also of moving machines noticeable in many areas, focused attention on grass mowers which could be converted into reapers by means of especially fitted cutting devices. Above all, however, the smaller and medium-sized agricultural holding demands the introduction of aids which meet its particular needs, e.g. assembled equipment, smaller hoeing machines and other smaller but efficient equipment."*

The following interesting observation is also made :

*"Moreover, the tests prescribed by the German Agricultural Association had a considerable influence on the number of applications in the various subclasses. Testing of manure spreaders or potato harvesters gave rise in recent years to a flood of applications for machines of this type, especially as they can be developed for mass use. Similar influences are to be expected for the same reason in the near future in the case of potato planters, loading and unloading devices and hay and straw balers." \*\*)*

---

\*) Die Geschäftstätigkeit des kaiserlichen Patentamtes und die Beziehungen des Patentschutzes zu der Entwicklung der einzelnen Industriezweige Deutschlands in den Jahren 1891 bis 1900, supplementary volume to the Blatt für Patent-, Muster- und Zeichenwesen, Volume 1901, Karl Heymanns Verlag, Berlin, 1902, p. 19.

\*\*\*) Die Geschäftstätigkeit ..., pp. 84 - 85.

[3] "As far as the basic process was concerned, everything that could be wished for had more or less been achieved, and the many patents taken out in the previous decade had clearly long since filled all the gaps. This also explains why there are only a few patents in this area, such as 56181 for plug ramming." \*)

[4]"There has been a noticeable decline in inventive activity with the improvement of the ordinary oil lamp, although the demand for oil, table and hanging lamps is still there and it cannot be assumed that these lamps have already achieved their optimum efficiency. The few patents taken out on the manufacture of non-flammable wicks and safety devices for the prevention of explosions in the event of the lamps falling over have acquired no importance. This standstill can undoubtedly be attributed to the rapid spread of incandescent-gas lighting and to the fact that inventors regard the oil lamp without a mantle, such as the Argand or slit burner, as a completely outdated appliance, any improvement to which can no longer be expected to yield worth while patents. The situation here is therefore that the benefits anticipated by the inventor in a related area have led to a reduction of inventive activity in a less promising area." \*\*)

[5] "In subclass 21f, 'Electric lighting', the number of applications suddenly almost doubled in a year from 1897 to 1898. A considerable proportion of these additional applications can be attributed to the revival of the efforts to improve the incandescent lamp brought about by Nernst's discovery; the development of continuous-arc lamps and lamp carbons goes hand in hand with these efforts." \*\*\*)

[6] It says here :

"It is noticeable that foreigners account for a high proportion of the patents in Class 29 (= yarns, author's note) and that of the patents granted in the last ten years up to 1 April 1901 only 37 % went to Germany, the remainder being spread over Great Britain (24 %), France (17 %), Belgium (9 %), America (5 %), Switzerland (4 %), Austria-Hungary (2 %), Sweden (1 %) and Italy, Russia and Australia (1 % altogether). Britain's supply of new types of yarn comes mainly from its colonies; it is thus in a position to encourage the inventive spirit and give it free scope. In Germany, on the other hand, some of the inventions, such as processes and machines for producing yarns from China grass, etc., cotton gins and so on, were just not possible; they were not adopted until some years later. The situation in France is similar to that in Britain, albeit to a lesser extent; in addition, it has a large wool and cloth industry,

---

\*) Die Geschäftstätigkeit ..., p. 13.

\*\*) Die Geschäftstätigkeit ..., p. 29.

\*\*\*) Die Geschäftstätigkeit ..., p. 121.

*necessitating the carbonization and scouring of wool, improvements to which are the subjects of a considerable number of French patents." \*)*

In the same chapter the following observation is made with regard to Class 73 :

*"The area covered by Class 73 'Ropes' is very narrow and innovations of the products, machines and devices are rare. The average number of patents a year is only five. Apart from Germany, which in the ten-year period took out 85 % of the patents, the only other countries concerned are America, Belgium and Austria-Hungary with 5 % each and Denmark with 1 %." \*\*)*

---

\*) Die Geschäftstätigkeit ..., p. 61.

\*\*\*) Die Geschäftstätigkeit ..., p. 64.

C. KOLLE IN NIEDERSCHÖNHAUSEN.

Fangvorrichtung für Insecten.

Fig. 1.

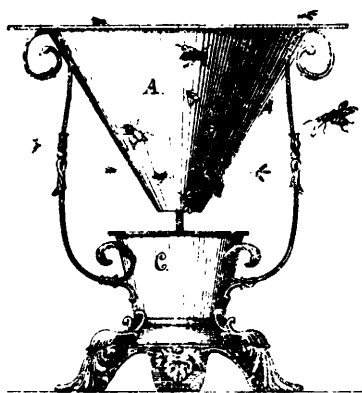

Fig. 2.

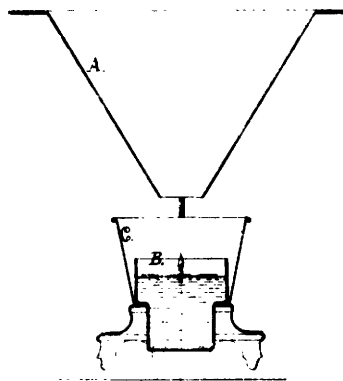
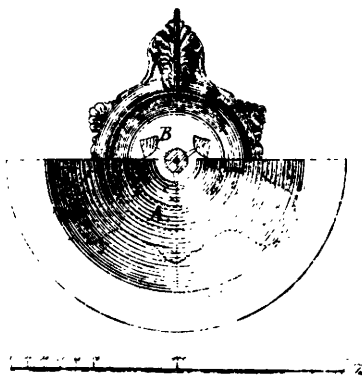

Fig. 3.



Zu der Patentschrift

**№ 137.**

PHOTOG. DRUCK DER KÖNIGL. PREUSS. STAATSDRUCKEREI.

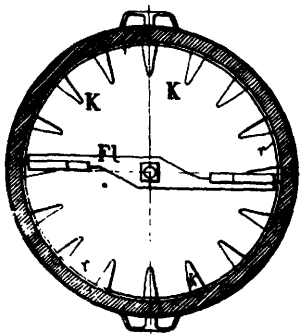
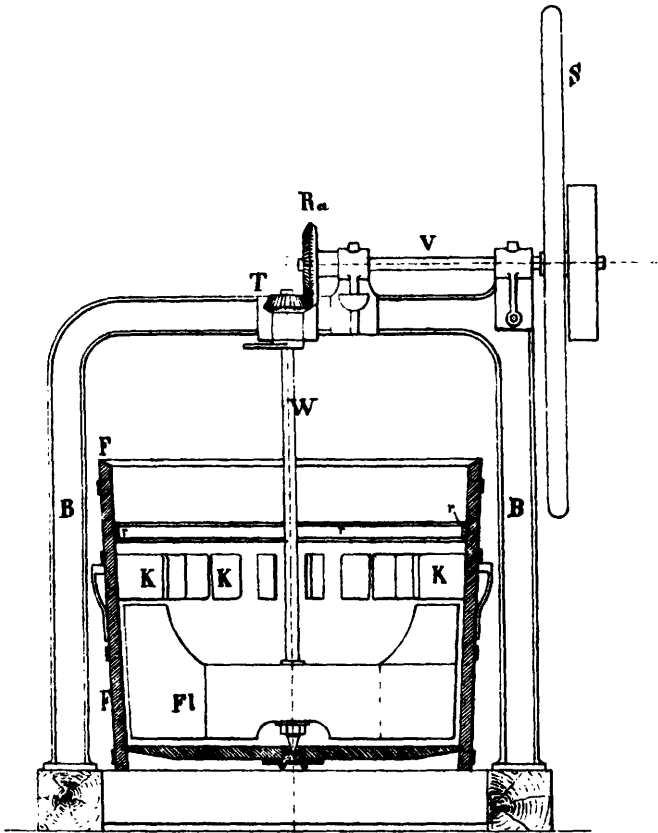

*Grundriss des  
Fusses.*

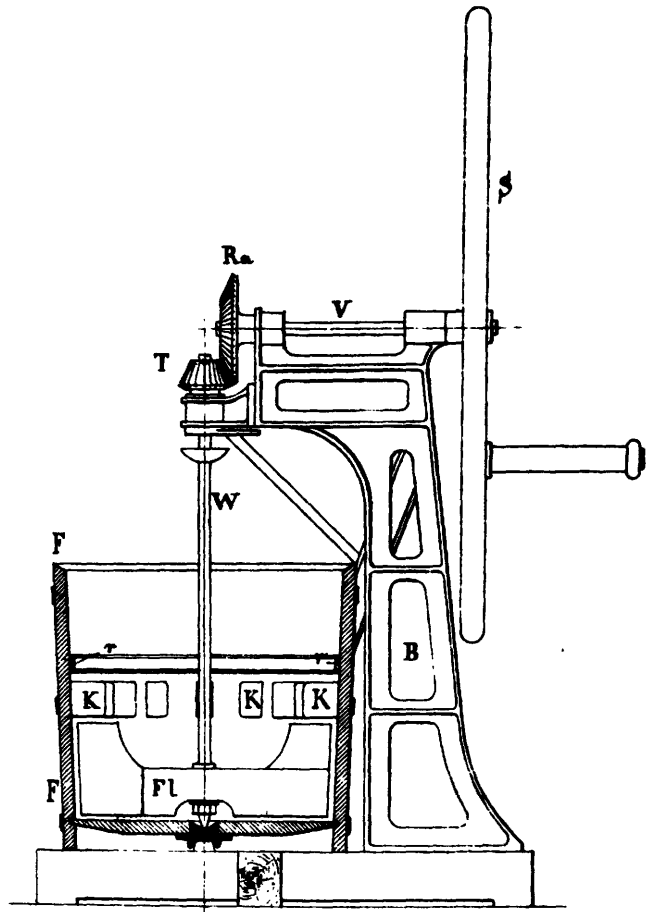

# Annex

\*

Trends  
in the filing of patent  
applications

(Report EUR 7872EN)



TRENDS IN THE FILING OF PATENT APPLICATIONS  
IN GERMANY/THE FEDERAL REPUBLIC OF GERMANY  
BETWEEN 1877 AND 1980

INTRODUCTION

The old German patent classification was little changed. There were not many basic changes to the contents of a class. The most important cases were as follows : class 7, originally entitled "Sheet metal and wire production and treatment" later became "Mechanical metal working without essentially removing material; punching metal". Class 43 "Basketry" was changed to "checking devices", class 62 "Salts" to "Air travel" (originally included under class 77 "Sport"), class 75 "Soda, potash and alcalies" to "Sculpture, painting and surface decoration". There were, however, many changes within individual classes. Presenting such changes can help in interpreting the trends in technological development. Following adoption of the German patent law and the setting up of the German patent office in 1877, until 1974. This offered a rare opportunity to classify and examine annual applications for patents in all existing 89 patent classes over that period. The fact that both national and foreign patents were covered made it possible - assuming that the number of patent applications in individual fields (classes, branches), is a measure of technical development - to carry out a survey entitled "100 years of world technology trends as reflected by German patent statistics".

The 100-year time series showing the trends in patent applications in Germany are being published here for the first time on such a scale. They were taken from annual volumes of the periodicals "Patentblatt" (founded in 1877) and "Blatt für Patent, Muster und Zeichenwesen" (founded in 1894).

The data series and the corresponding illustrations over the sum total of patent applications and patents granted, and these have been further subdivided into applications by and patents granted to nationals and foreigners.

Furthermore, the annual figures for patent applications are arranged according to the 89 classes of the patent classification. Although it was possible to reconstruct the trend not given in the official publication for the years 1915 - 1918, it was not possible to do so for the second world war period.



The charts showing developments in individual patent classes make it an easy matter to follow the concentration of the main trends (over the whole period), trends during shorter periods (e.g. until 1914, between the two world wars, in the Federal Republic of Germany), fluctuations in these trends, the influence of significant external and internal major influences (such as both world wars, economic crises – particularly during the 1930s, territorial changes, etc.), the turning points after a continuous tendency (particularly maxima and minima of different types) and so on.

The first of the charts based on patent classes 1 to 89 shows the development in the absolute manner of patent applications; sliding averages of numbers per year were used, for periods of five years, to compensate for short-term fluctuations. The x-axis indicates the year, the y-axis the number of applications. The figure for single years are given on the top edge of the chart. The lower chart shows the same development as a proportion, in thousands, of a given class in the overall number of applications. The figures of individual years are again given on the top edge.

1. Total Patent Applications and Grants,  
broken down into Nationals and Foreigners  
in Germany for the years 1877 - 1980

1. Total patent applications and grants, broken down into nationals and foreigners in Germany (or in the Federal Republic) for the years 1877 - 1980.

Year	Patent appl. total	Patent grants	Patent appl. foreigners	Patent grants	Patent appl. nationals	Patent grants nationals
1877	3212	190	.	.	.	.
1878	5949	4200	.	.	.	.
1879	6528	4410	.	.	.	.
1880	7017	3966	.	.	.	.
1881	7174	4339	.	1199	.	3140
1882	7569	4131	.	1246	.	2885
1883	8121	4848	.	1507	.	3341
1884	8607	4459	.	1547	.	2912
1885	9408	4018	.	1416	.	2602
1886	9991	4008	.	1285	.	2723
1887	9904	3882	.	1321	.	2561
1888	9869	3923	.	1376	.	2547
1889	11645	4406	.	1485	.	2921
1890	11882	4680	.	1620	.	3060
1891	12919	5550	.	1919	.	3631
1892	13126	5900	.	1965	.	3935
1893	14265	6430	.	2087	.	4343
1894	14964	6280	.	2066	.	4214
1895	15063	5720	.	1899	.	3821
1896	16486	5410	.	1922	.	3488
1897	18347	5440	.	1983	.	3457
1898	20321	5570	.	2097	.	3473
1899	21080	7430	6637	2747	14443	4683
1900	21925	8784	7077	3244	14848	5540
1901	25165	10508	7543	3899	17622	6609
1902	27565	10610	7919	3913	19646	6697
1903	28313	9964	7792	3629	20521	6335
1904	28360	9189	7351	3285	21009	5904
1905	30085	9600	8055	3310	22030	6290
1906	33822	13430	8446	4689	25376	8741
1907	36763	13250	8873	4454	27890	8796
1908	40312	11610	8680	3765	31632	7845
1909	44411	11995	9413	3829	34991	8166
1910	45209	12100	10019	3706	35190	8394
1911	44929	12640	10446	4069	34483	8571
1912	45815	13080	10704	4249	35111	8831
1913	49532	13520	11250	4473	38282	9047
1914	36772	12350	7998	3716	28774	8634
1915	21041	8190	3621	.	17420	8190
1916	24469	6271	3603	.	20866	6271
1917	24458	7399	3268	.	21190	7399
1918	30049	7340	3465	.	26584	7340
1919	43279	7766	4736	1239	38543	6527
1920	53527	14452	11672	3922	41855	10530
1921	56721	15642	10720	3591	46001	12051
1922	51762	20715	10885	5346	40877	15369
1923	45209	20526	9127	5703	36082	14823
1924	56831	18189	9353	5424	47478	12765
1925	64910	15877	10508	4224	54402	11653
1926	64384	15500	11159	3854	53225	11646
1927	68457	15265	12827	3720	55630	11545
1928	70895	15598	14200	3761	56695	11837
1929	72748	20202	15226	5219	57522	14983
1930	78400	26737	15749	7140	62651	19597

Total patent applications and grants, broken down into nationals and foreigners, in Germany (or in the Federal Republic) for the years 1877 - 1980

(contd.)

Year	Patent appl. total	Patent grants total	Patent appl. foreigners	Patent grants foreigners	Patent appl. nationals	Patent grants nationals
1931	72686	25846	14225	7123	58461	18723
1932	63414	26201	11899	7237	51515	18964
1933	55992	21755	11011	5637	44981	16118
1934	52856	17011	9742	4210	43114	12801
1935	53592	16139	8912	3971	44680	12168
1936	56163	16750	8800	4086	47363	12664
1937	57139	14526	8629	3208	48510	11318
1938	56217	15068	7976	3019	48241	12049
1939	47555	16525	.	.	.	.
1940	43479	14647	.	.	.	.
1941	49885	14809	.	.	.	.
1942	54386	14648	.	.	.	.
1943	49060	14883	.	.	.	.
1944	.	.	.	.	.	.
1945	.	.	.	.	.	.
1946	.	.	.	.	.	.
1947	.	.	.	.	.	.
1948	.	.	.	.	.	.
1949	61002	.	.	.	.	.
1950	53375	2383	9919	86	43456	2297
1951	55457	27767	9747	5806	45710	21961
1952	58561	37179	10702	9446	47859	27733
1953	60202	37113	12643	7608	47559	29505
1954	59317	19140	14458	4061	44859	15079
1955	54865	14760	15862	3511	39003	11249
1956	53470	18150	17156	4838	36314	13312
1957	53002	20467	18216	6062	34786	14405
1958	54502	19637	19060	6297	35442	13540
1959	56611	22556	21375	7984	35236	14572
1960	57123	19666	22546	7157	34577	12509
1961	58188	20550	23771	7977	34417	12573
1962	59783	18508	24736	7538	35047	10970
1963	61031	15542	25926	6189	35105	9353
1964	64775	19597	28682	7933	36093	11664
1965	66470	16780	30182	7118	36288	9662
1966	67468	22598	32406	9980	35062	12618
1967	67495	19871	32098	8852	35397	11019
1968	65422	21169	32830	9535	32592	11634
1969	66626	22623	34555	10620	32071	12003
1970	66132	12887	34665	6630	31467	6257
1971	65756	18149	33956	9967	31800	8182
1972	67354	20600	34976	11092	32378	9508
1973	66223	23934	35264	12919	30959	11015
1974	63545	20539	33011	10746	30534	9793
1975	60095	18290	29897	9213	30198	9077
1976	61705	20965	30640	10570	31065	10395
1977	60401	21749	30154	10934	30247	10815
1978	58492	23514	28184	11775	30308	11739
1979	55184	22534	24305	11639	30879	10895
1980	48583	20188	19900	10362	28683	9826

Development of the total number of patent applications (-A-A-), patents granted (-P-P-), patent applications filed by foreigners (-+--+), and patents granted to foreigners (-\*-\*) in Germany (or in the Federal Republic) in the years 1877 - 1980

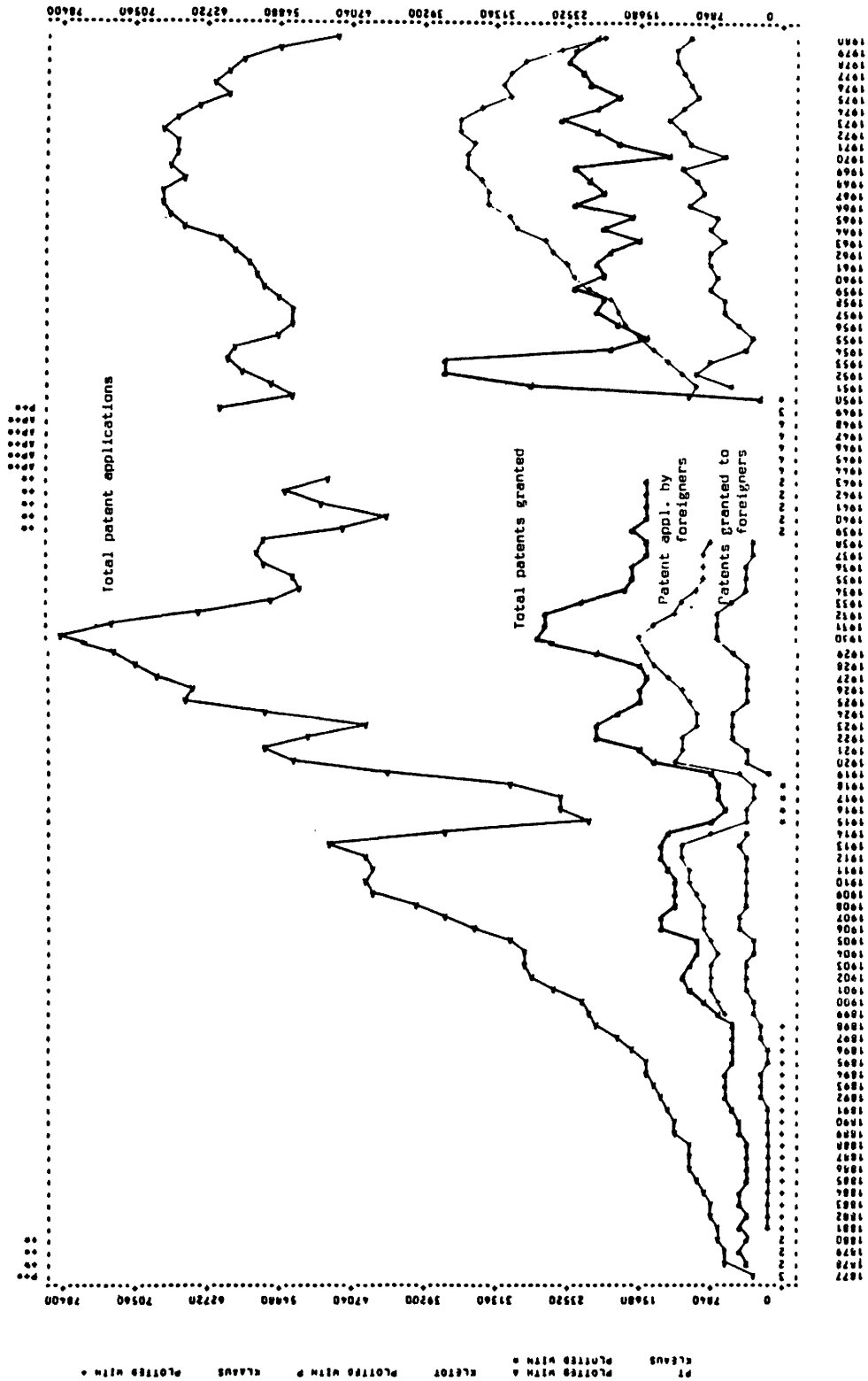

Patent applications made by nationals (-I-I-) and foreigners (-A-A-) in Germany (or in the Federal Republic) in the years 1899 - 1980

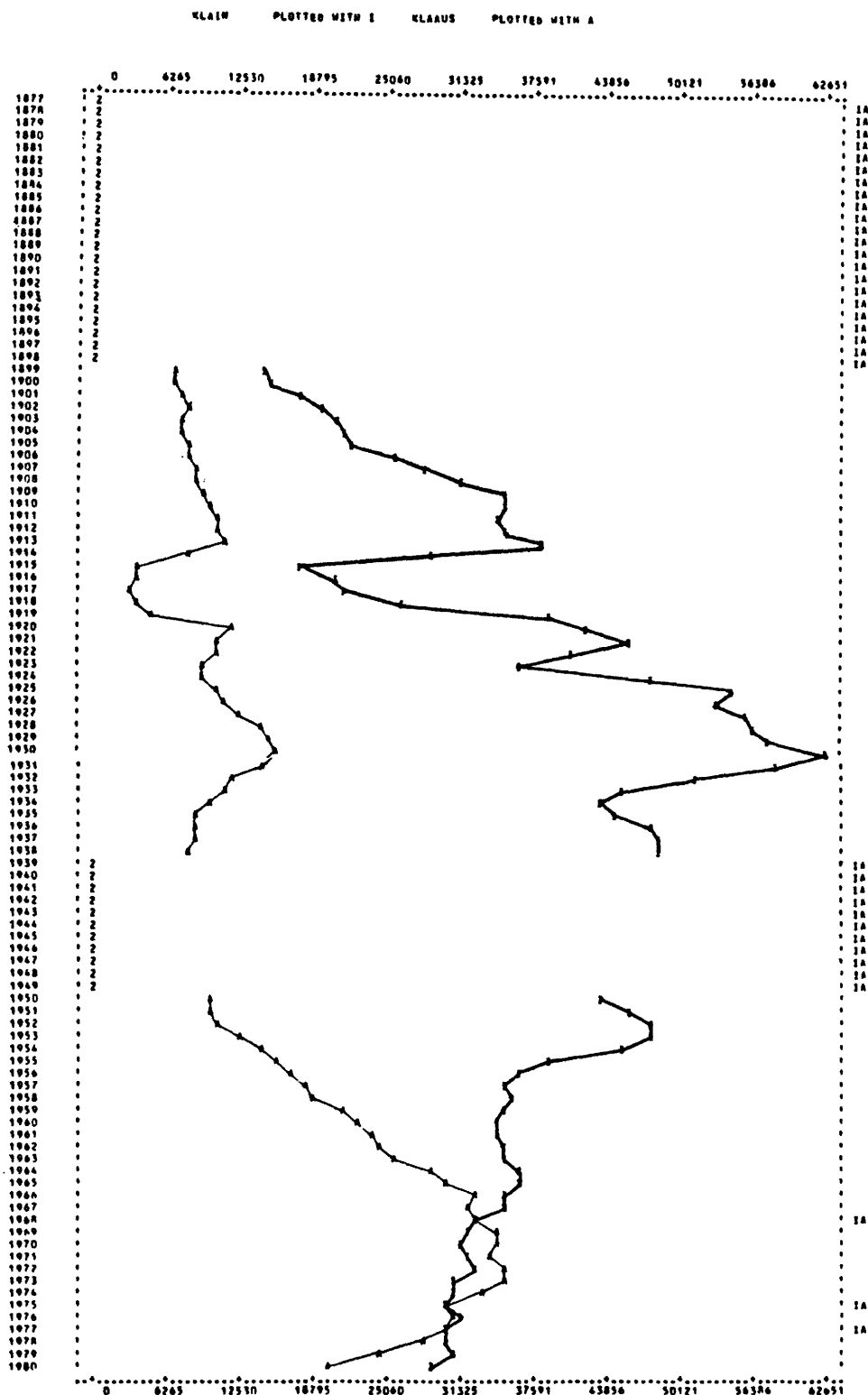

Patents granted to nationals (-I-I-) and foreigners (-A-A-) in Germany (or in the Federal Republic) in the years 1881 - 1980

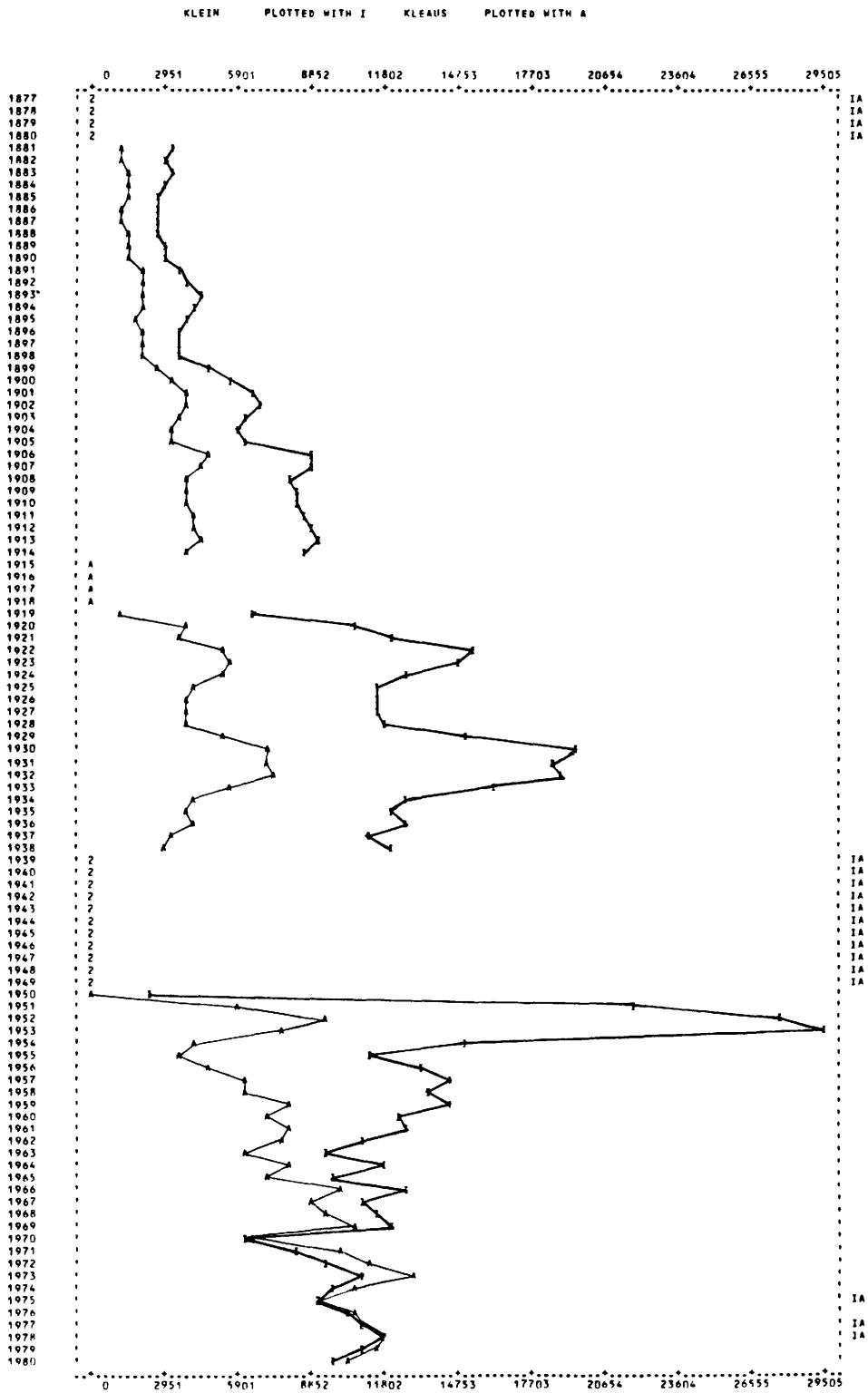

Development in the proportion of patent applications filed by foreigners and total patent applications in Germany (or in the Federal Republic)

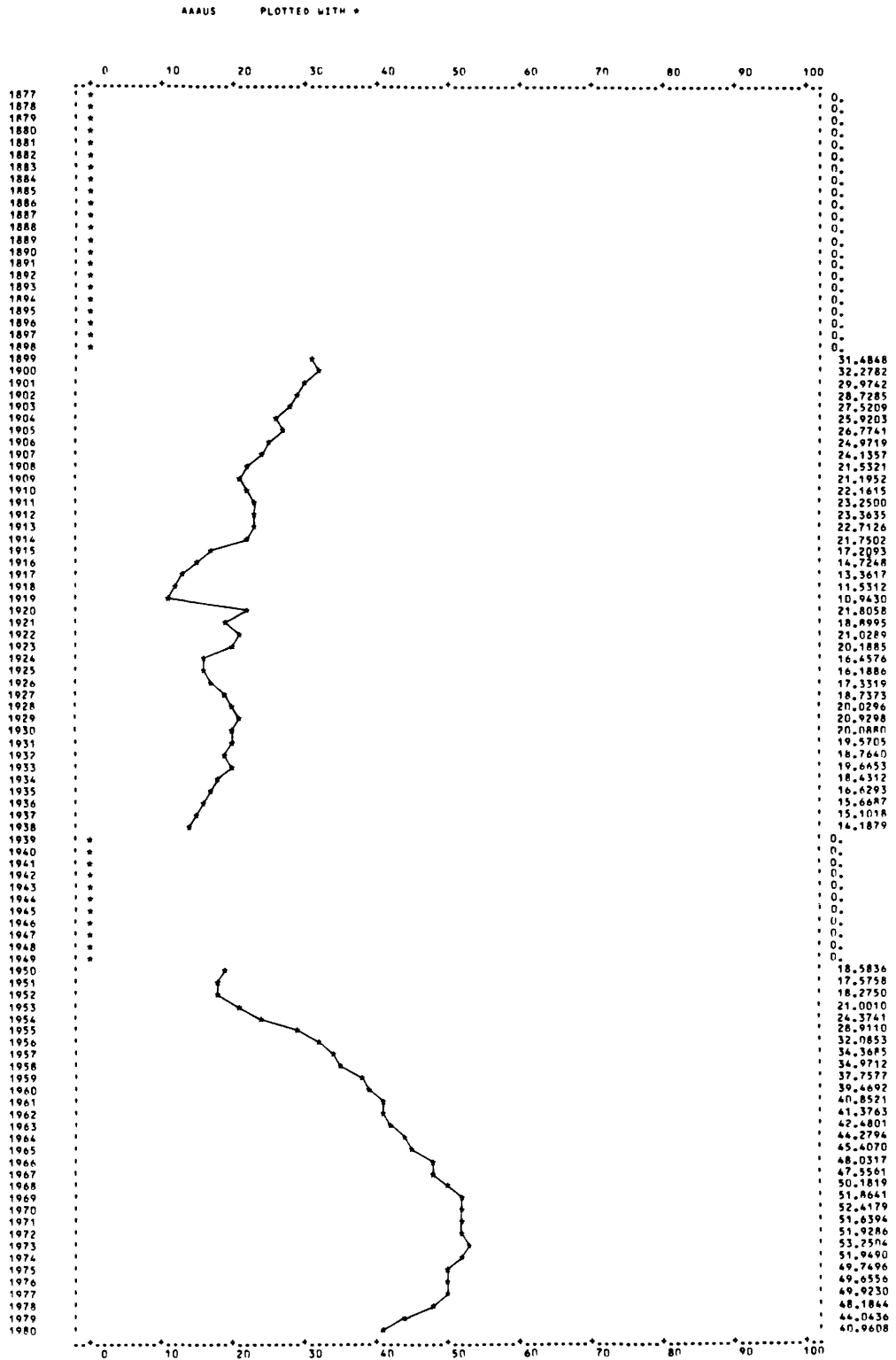



Development in the proportion of patents granted to foreigners and total patents granted in Germany (or in the Federal Republic)

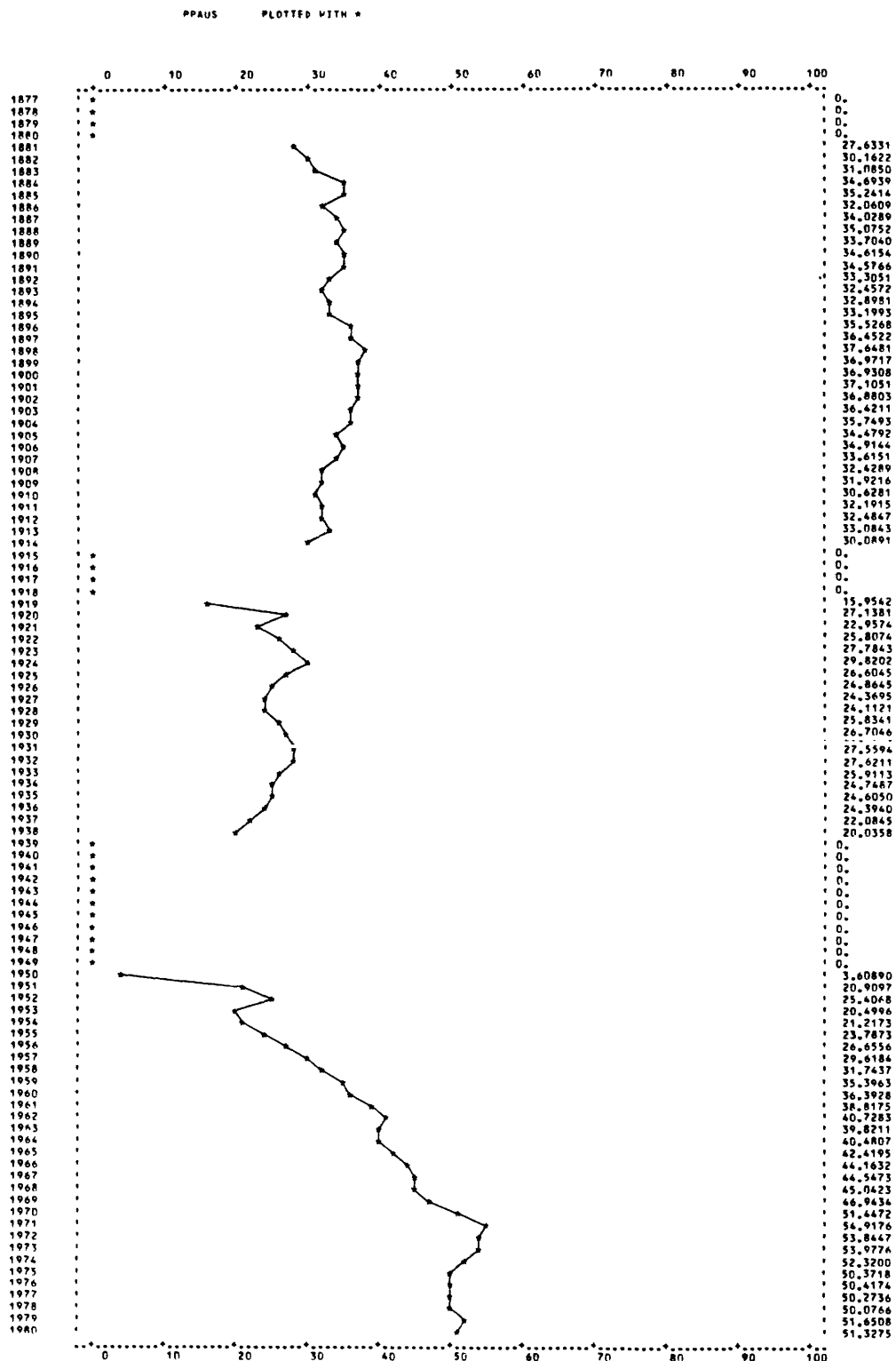

Development in the proportion of the annual number of patents granted and total patent applications

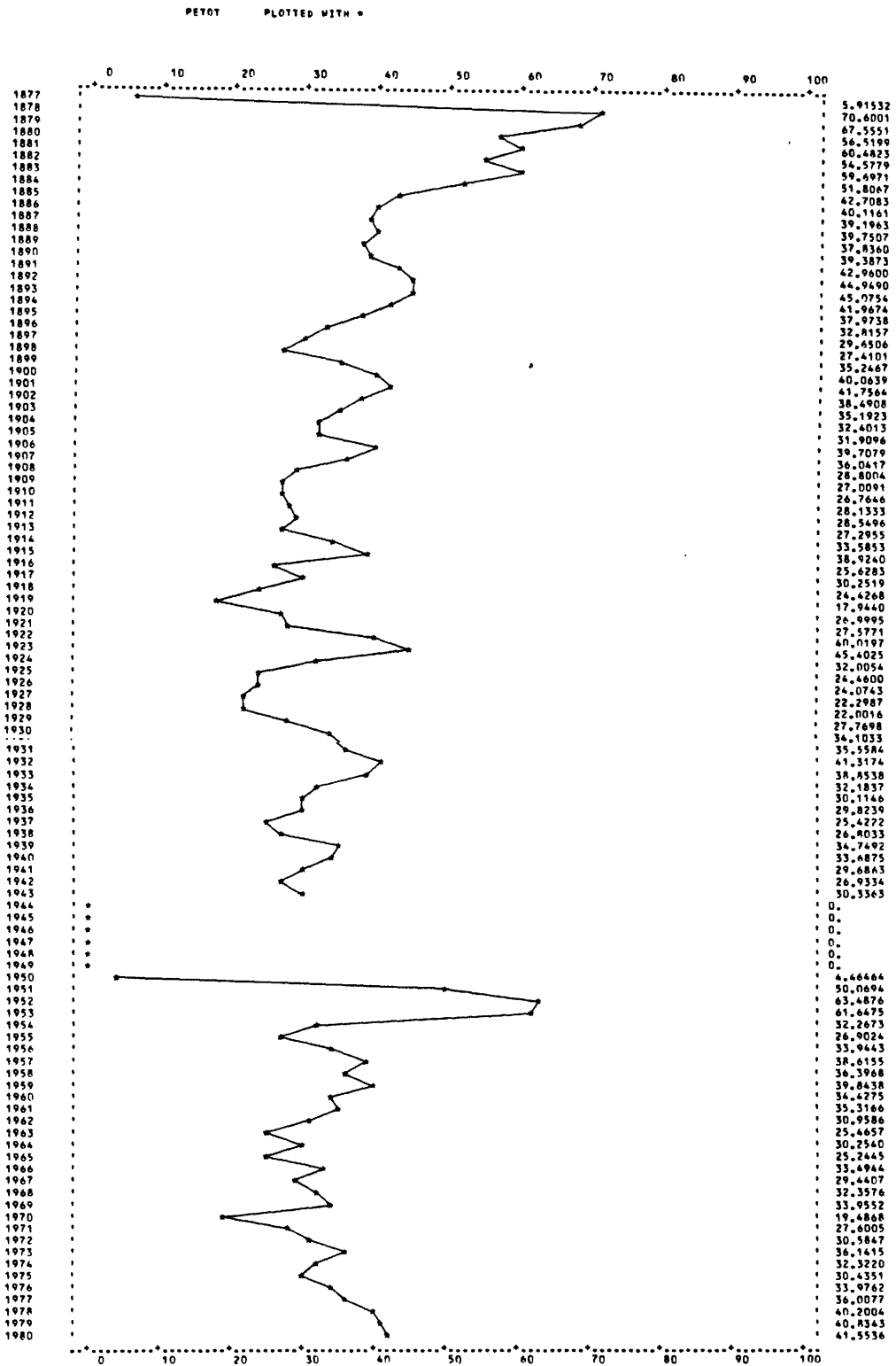

Development in the proportion of the annual number of patents granted to and applications filed by foreigners

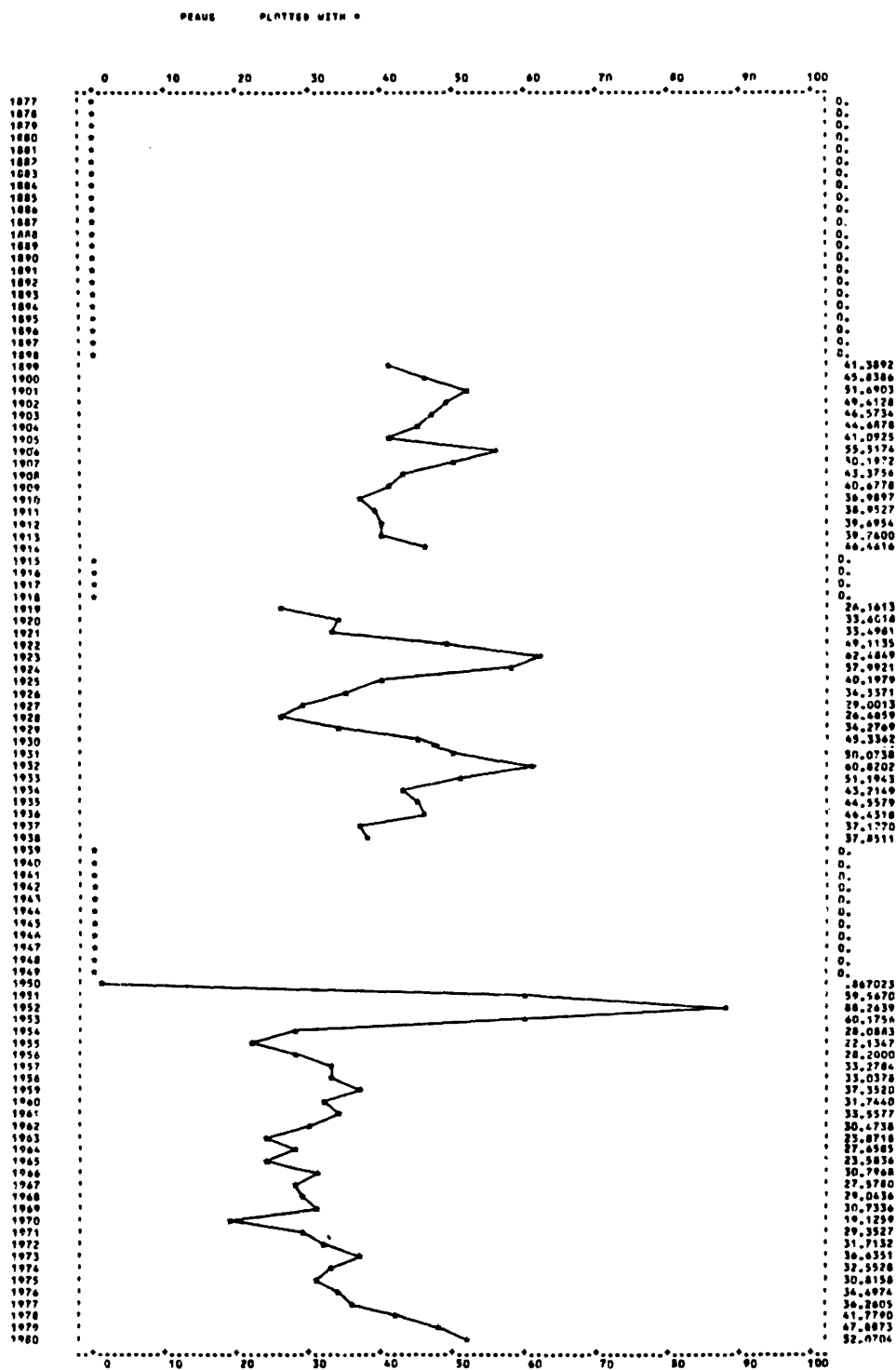

CARL BORTFELDT IN BREMEN.

Verfahren zur Herstellung von Filzunterlagen zu Hüten.

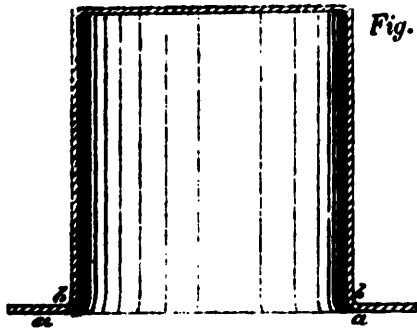

Fig. 1.

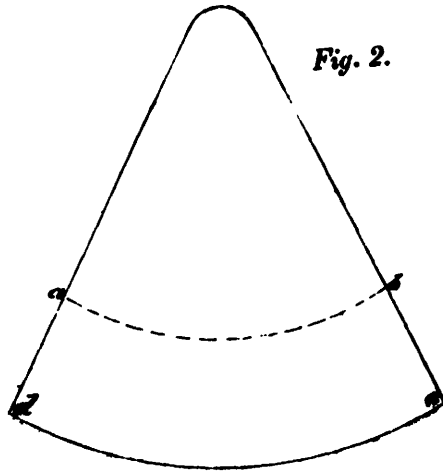

Fig. 2.

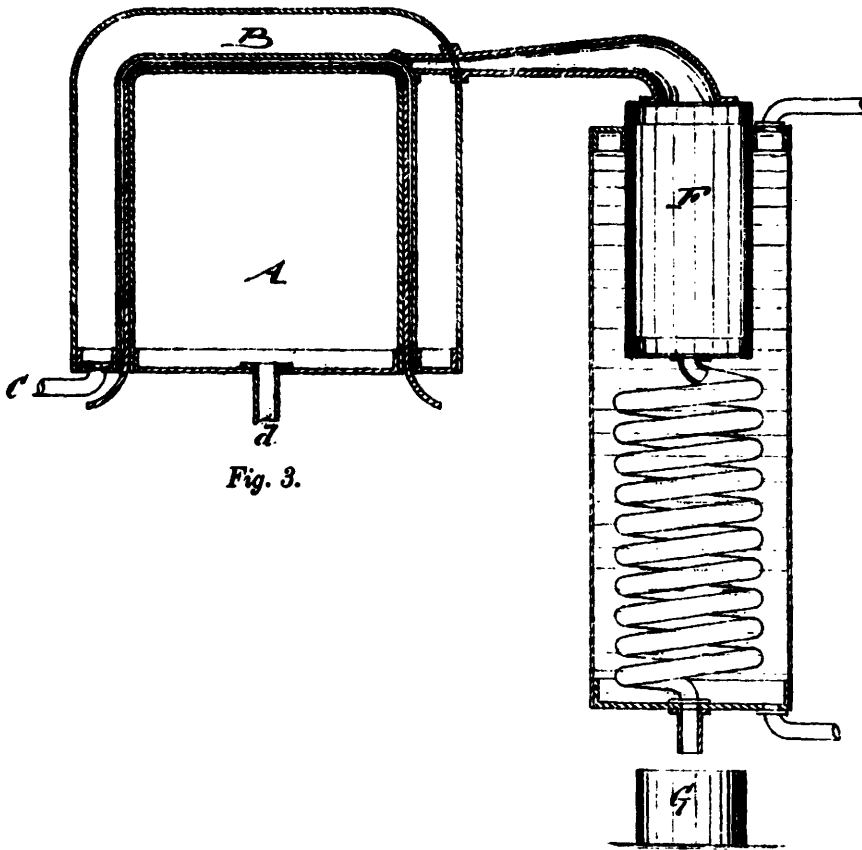

Fig. 3.

Zu der Patentschrift

№ 94.

PHOTOGR. DRUCK DER KÖNIGL. PREUSS. STAATSDRUCKEREI.

GUSTAV LINCK IN STUTTGART.

Serviettenhalter.

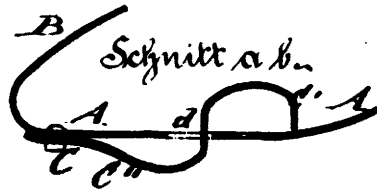

Oberer Ansicht

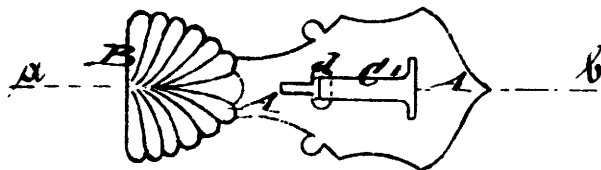

Untere Ansicht

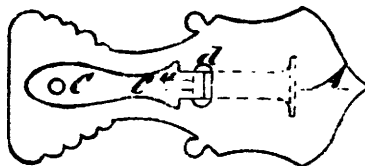

Zu der Patentschrift

**№ 24.**

PHOTOGR. DRUCK DER KÖNIGL. PREUSS. STAATSDRUCKEREI.

2. Total Patent Applications  
in Germany broken down by Classes  
of the German Patent Classification  
in the years 1881 - 1973

2. Patent applications in Germany (or in the Federal Republic), broken down by classes of the German patent classification, in the years 1881 - 1973

Year	Cl. 1	Cl. 2	Cl. 3	Cl. 4	Cl. 5	Cl. 6	Cl. 7	Cl. 8	Cl. 9
1881	16	28	75	148	38	142	28	137	22
1882	18	24	101	152	27	122	27	155	22
1883	6	28	100	156	57	135	22	143	20
1884	21	35	116	157	62	135	18	167	27
1885	19	39	157	192	62	160	26	186	20
1886	25	42	175	193	62	137	38	196	31
1887	25	39	149	167	42	147	25	164	30
1888	18	27	175	176	53	138	28	179	30
1889	25	39	232	223	57	165	25	185	43
1890	32	23	244	199	45	174	18	180	28
1891	39	34	172	192	53	153	26	174	43
1892	35	39	198	167	54	203	23	226	34
1893	32	51	217	190	44	210	27	258	43
1894	24	55	193	208	52	182	24	308	42
1895	29	65	231	304	44	160	38	265	37
1896	36	63	193	249	46	156	22	322	37
1897	46	52	219	288	43	181	14	366	35
1898	52	67	208	209	69	176	20	369	40
1899	35	44	249	226	104	162	18	381	40
1900	53	71	243	497	109	198	301	476	45
1901	46	96	217	626	164	231	329	532	68
1902	71	117	312	680	173	244	375	662	75
1903	89	142	351	658	171	203	363	592	110
1904	81	173	346	664	173	224	325	642	98
1905	93	166	345	782	179	237	288	640	112
1906	62	153	413	797	206	240	372	741	99
1907	64	160	456	793	319	232	405	803	130
1908	84	198	534	968	297	230	348	840	130
1909	88	224	623	1016	335	261	434	816	155
1910	101	199	728	927	308	267	432	850	172
1911	104	295	730	801	254	226	440	767	149
1912	102	223	820	789	241	244	496	768	166
1913	153	247	968	753	275	234	465	800	195
1914	85	220	618	501	188	165	360	591	120
1915	35	72	193	260	79	83	249	309	55
1916	41	84	224	302	92	97	290	359	64
1917	41	84	224	302	92	97	290	359	64
1918	51	103	276	371	113	119	356	441	79
1919	98	138	698	716	158	100	399	483	233
1920	166	185	707	834	230	92	492	580	239
1921	143	177	684	702	369	107	490	603	265
1922	129	144	533	552	379	123	398	598	221
1923	125	111	433	509	280	87	448	582	153
1924	131	186	522	539	407	107	579	861	227
1925	136	351	632	664	509	175	648	952	284
1926	127	332	612	632	449	165	590	1107	297
1927	143	381	617	617	480	202	709	1241	327
1928	147	322	662	736	483	196	702	1237	298
1929	157	299	698	733	509	235	794	1243	248
1930	217	333	755	753	543	239	820	1345	275
1931	261	268	652	599	557	224	764	1217	282
1932	261	277	606	515	489	203	649	1024	266
1933	160	248	585	472	301	146	526	913	201
1934	176	231	511	390	329	145	557	876	178
1935	151	180	508	426	310	149	510	839	160
1936	153	169	526	446	272	168	564	901	170
1937	155	208	480	470	261	172	605	867	142
1938	127	165	436	461	317	172	620	793	148

Patent applications in Germany (or in the Federal Republic), broken down by classes of the German patent classification, in the years 1881 - 1973

(contd.)

Year	Cl. 1	Cl. 2	Cl. 3	Cl. 4	Cl. 5	Cl. 6	Cl. 7	Cl. 8	Cl. 9
1939	.	.	.	.	.	.	.	.	.
1940	.	.	.	.	.	.	.	.	.
1941	.	.	.	.	.	.	.	.	.
1942	.	.	.	.	.	.	.	.	.
1943	.	.	.	.	.	.	.	.	.
1944	.	.	.	.	.	.	.	.	.
1945	.	.	.	.	.	.	.	.	.
1946	.	.	.	.	.	.	.	.	.
1947	.	.	.	.	.	.	.	.	.
1948	.	.	.	.	.	.	.	.	.
1949	159	283	569	305	1250	174	610	829	171
1950	146	155	574	333	709	125	499	846	187
1951	180	142	515	344	714	114	563	899	184
1952	164	151	535	403	707	101	595	862	166
1953	124	183	595	405	842	105	592	970	119
1954	146	159	614	330	755	86	607	1061	152
1955	140	153	427	259	569	82	582	1109	98
1956	131	134	394	231	690	95	600	1034	92
1957	134	113	335	238	761	90	589	1002	98
1958	124	120	332	214	746	96	603	995	103
1959	137	115	319	208	713	97	611	1059	87
1960	93	123	299	178	598	93	691	1039	79
1961	106	126	252	170	544	149	638	1126	75
1962	101	144	215	189	484	145	589	1080	90
1963	109	103	236	197	557	145	648	1204	100
1964	119	128	201	273	633	143	650	1194	100
1965	102	135	196	278	684	187	678	1135	100
1966	74	101	212	267	589	176	655	1296	86
1967	82	126	215	257	519	170	707	1133	87
1968	68	107	227	241	407	209	765	1122	70
1969	85	101	243	253	449	242	887	1103	64
1970	66	101	191	193	453	233	808	1151	73
1971	98	96	155	191	472	191	750	993	60
1972	101	102	154	155	431	201	769	1090	69
1973	92	90	145	129	430	198	762	861	72



Patent applications in Germany (or in the Federal Republic), broken down by classes of the German patent classification, in the years 1881 - 1973

Year	Cl. 10	Cl. 11	Cl. 12	Cl. 13	Cl. 14	Cl. 15	Cl. 16	Cl. 17	Cl. 18
1881	41	42	78	137	92	91	7	19	57
1882	46	62	73	118	78	103	14	7	38
1883	54	68	88	190	86	114	25	12	40
1884	42	61	120	183	80	111	32	32	53
1885	50	83	99	233	126	156	29	45	68
1886	33	82	104	271	122	145	28	25	45
1887	34	98	101	204	115	165	17	28	45
1888	28	89	120	202	136	150	15	24	33
1889	51	86	169	237	144	189	10	31	27
1890	43	105	169	262	137	177	16	29	38
1891	44	82	171	264	162	183	15	32	32
1892	55	68	270	289	144	174	16	39	32
1893	41	63	288	203	145	166	27	52	35
1894	50	71	512	238	161	199	41	101	35
1895	44	80	505	220	171	205	29	89	44
1896	65	80	558	255	185	235	33	95	43
1897	79	88	547	262	217	248	44	89	36
1898	85	88	600	277	269	312	28	120	57
1899	89	103	693	276	303	356	33	127	56
1900	119	125	766	300	361	478	23	113	67
1901	139	138	854	369	426	568	31	159	92
1902	163	177	887	390	472	582	46	201	102
1903	172	149	862	412	557	568	31	192	111
1904	136	178	879	386	597	522	33	136	115
1905	123	166	885	412	541	590	37	161	112
1906	136	170	1043	313	582	611	31	241	137
1907	163	178	1113	348	582	710	44	220	136
1908	183	222	1082	374	572	722	68	222	186
1909	192	229	1140	431	610	781	49	228	200
1910	202	213	1206	447	596	754	70	246	239
1911	216	213	1315	374	599	746	61	266	230
1912	209	271	1475	393	476	760	72	227	235
1913	238	275	1662	443	470	939	75	224	216
1914	193	177	1266	369	342	625	50	229	186
1915	102	114	1123	162	186	207	62	109	134
1916	119	132	1305	189	216	241	72	127	156
1917	119	132	1305	189	216	241	72	127	156
1918	146	163	1603	232	265	296	89	156	192
1919	361	227	1302	344	290	508	108	221	181
1920	597	270	1730	447	357	815	110	263	244
1921	510	305	1868	457	442	925	142	332	302
1922	423	290	2067	511	478	940	114	361	244
1923	323	222	1834	500	480	810	81	304	199
1924	433	281	2357	856	491	994	96	406	350
1925	462	350	2460	795	419	1075	105	444	457
1926	449	424	2692	682	377	1109	93	530	491
1927	459	440	3064	584	432	1169	146	514	476
1928	391	437	3022	541	422	1179	188	559	529
1929	410	388	3119	556	422	1225	208	540	537
1930	413	455	3357	568	431	1211	252	611	605
1931	319	430	2709	505	397	1206	188	555	515
1932	256	357	2294	384	270	1039	179	485	505
1933	258	310	1937	339	270	909	130	501	482
1934	305	287	1988	338	264	794	106	448	404
1935	244	332	2003	312	253	750	80	431	475
1936	277	285	2351	342	217	791	106	475	552
1937	336	304	2828	294	245	812	120	487	558
1938	333	302	2673	308	221	730	105	473	620

Patent applications in Germany (or in the Federal Republic), broken down by the classes of the German patent classification, in the years 1881 - 1973

(contd.)

Year	Cl. 10	Cl. 11	Cl. 12	Cl. 13	Cl. 14	Cl. 15	Cl. 16	Cl. 17	Cl. 18
1939	.	.	.	.	.	.	.	.	.
1940	.	.	.	.	.	.	.	.	.
1941	.	.	.	.	.	.	.	.	.
1942	.	.	.	.	.	.	.	.	.
1943	.	.	.	.	.	.	.	.	.
1944	.	.	.	.	.	.	.	.	.
1945	.	.	.	.	.	.	.	.	.
1946	.	.	.	.	.	.	.	.	.
1947	.	.	.	.	.	.	.	.	.
1948	.	.	.	.	.	.	.	.	.
1949	214	363	2691	307	160	577	107	447	509
1950	139	266	2598	248	119	614	81	476	452
1951	201	262	2740	228	112	629	97	475	500
1952	209	301	3216	250	139	611	85	523	550
1953	140	363	3166	217	153	641	90	528	532
1954	131	339	3116	189	202	685	110	428	517
1955	126	316	3313	181	159	603	105	401	470
1956	117	252	3589	184	135	524	76	369	470
1957	150	265	3586	170	139	523	48	471	510
1958	115	261	4054	155	121	544	57	442	477
1959	122	265	4569	167	157	598	65	486	538
1960	97	212	4671	129	161	572	55	486	567
1961	84	235	4877	127	181	606	71	500	639
1962	75	256	5066	151	150	660	89	505	600
1963	77	234	5067	147	141	560	74	545	557
1964	77	232	5385	142	108	624	69	549	487
1965	74	259	5546	135	149	574	56	534	482
1966	78	243	5781	138	166	628	66	525	474
1967	75	216	5944	153	259	704	84	584	479
1968	68	168	6046	93	336	788	68	500	378
1969	63	202	6017	99	608	695	61	503	372
1970	91	218	6140	71	655	692	61	487	339
1971	82	189	6070	68	690	749	47	512	314
1972	99	179	6122	98	756	847	57	495	296
1973	85	198	5936	90	732	894	53	545	281

Patent applications in Germany (or in the Federal Republic), broken down by classes of the German patent classificatio, in the years 1881 - 1973

Year	Cl. 19	Cl. 20	Cl. 21	Cl. 22	Cl. 23	Cl. 24	Cl. 25	Cl. 26	Cl. 27
1881	105	241	195	104	44	85	101	93	42
1882	99	220	335	138	45	84	73	96	49
1883	82	268	372	143	48	81	101	111	48
1884	143	302	292	123	53	92	96	100	41
1885	117	298	387	121	45	95	82	97	33
1886	100	266	395	191	80	114	98	137	56
1887	106	287	412	248	42	78	91	125	60
1888	86	263	383	229	55	74	95	125	46
1889	99	334	488	370	55	89	98	111	42
1890	129	374	510	367	69	82	107	111	65
1891	127	444	567	353	65	127	100	122	87
1892	118	477	563	412	71	116	84	111	69
1893	123	443	575	557	67	296	120	157	68
1894	114	494	603	348	75	289	128	197	79
1895	111	482	666	354	74	303	126	293	68
1896	111	609	723	295	97	261	96	544	72
1897	116	652	931	319	96	324	113	617	72
1898	135	736	1199	375	109	361	98	937	93
1899	129	851	1386	454	111	381	110	765	85
1900	149	897	1560	453	100	419	117	295	69
1901	206	1244	1828	441	96	492	129	292	80
1902	227	1420	1886	428	146	483	155	243	102
1903	252	1184	1874	430	166	538	136	261	97
1904	285	1010	1945	373	167	549	131	202	100
1905	239	935	2064	378	157	560	137	251	142
1906	266	1101	2527	409	171	546	156	199	129
1907	365	1233	2644	442	189	514	152	221	140
1908	372	1262	2720	463	160	530	196	235	145
1909	399	1244	2847	574	195	646	220	240	156
1910	397	1737	2774	497	184	624	202	214	176
1911	350	1344	2983	532	194	748	186	199	187
1912	377	1236	3017	488	217	695	234	198	176
1913	434	1277	3568	487	280	709	233	164	167
1914	311	973	2923	395	217	592	132	119	136
1915	121	384	1721	207	164	305	61	72	66
1916	141	446	2001	240	191	355	71	83	77
1917	141	446	2001	240	190	355	71	83	77
1918	173	548	2458	295	234	436	87	102	95
1919	227	973	3737	319	244	758	153	285	139
1920	258	1284	5052	406	245	1120	189	259	147
1921	282	1370	5620	457	322	975	233	206	184
1922	259	1184	5175	511	325	937	212	186	171
1923	200	1005	5163	481	287	833	237	157	172
1924	298	1419	6827	538	359	1125	287	196	156
1925	441	2422	7453	689	371	1069	318	198	169
1926	631	2046	7695	723	419	1026	343	204	164
1927	679	1861	8129	793	445	932	397	232	266
1928	697	1684	8476	876	433	1020	399	279	225
1929	645	1723	9537	764	442	891	436	214	225
1930	704	1591	11099	848	474	968	477	228	238
1931	568	1572	10933	748	465	865	377	181	214
1932	481	1358	9445	660	400	759	374	152	155
1933	491	1154	8034	567	341	731	325	121	166
1934	482	1055	7707	702	346	665	378	118	155
1935	434	1084	8431	684	321	717	307	168	160
1936	389	962	8711	675	328	704	356	185	178
1937	325	895	8805	738	388	595	366	137	207
1938	333	814	9353	614	359	551	268	137	202

Patent applications in Germany (or in the Federal Republic), broken down by classes of the German patent classification, in the years 1881 - 1973

(contd.)

Year	Cl. 19	Cl. 20	Cl. 21	Cl. 22	Cl. 23	Cl. 24	Cl. 25	Cl. 26	Cl. 27
1939	.	.	.	.	.	.	.	.	.
1940	.	.	.	.	.	.	.	.	.
1941	.	.	.	.	.	.	.	.	.
1942	.	.	.	.	.	.	.	.	.
1943	.	.	.	.	.	.	.	.	.
1944	.	.	.	.	.	.	.	.	.
1945	.	.	.	.	.	.	.	.	.
1946	.	.	.	.	.	.	.	.	.
1947	.	.	.	.	.	.	.	.	.
1948	.	.	.	.	.	.	.	.	.
1949	267	741	7951	520	285	612	248	202	177
1950	305	792	7207	452	264	554	230	141	173
1951	349	808	7980	537	328	710	312	108	204
1952	374	819	8435	471	370	625	330	110	199
1953	461	757	8457	479	343	643	327	111	271
1954	405	762	8099	539	395	593	277	100	261
1955	325	753	8021	515	426	604	237	114	240
1956	369	658	8041	531	473	542	236	98	289
1957	391	546	8079	601	349	513	242	77	239
1958	372	565	8473	562	337	448	243	82	229
1959	398	556	8696	658	347	443	231	65	259
1960	374	625	9194	706	338	500	220	71	264
1961	399	555	9619	665	358	455	223	73	255
1962	405	490	9538	715	326	453	204	55	251
1963	521	507	9597	692	375	419	255	62	203
1964	522	528	10387	725	360	402	228	59	233
1965	545	549	10709	711	372	438	243	75	235
1966	473	486	11174	329	402	332	244	50	236
1967	471	469	10706	778	409	369	264	49	185
1968	420	518	9966	714	400	368	302	35	183
1969	471	456	9819	824	424	333	301	33	197
1970	490	501	9010	914	441	325	295	33	163
1971	445	552	8838	927	412	374	313	40	175
1972	465	488	9213	910	458	381	305	53	203
1973	424	502	9321	841	427	434	264	60	201

Patent applications in Germany (or in the Federal Republic), broken down by classes of the German patent classification, in the years 1881 - 1973

Year	Cl. 28	Cl. 29	Cl. 30	Cl. 31	Cl. 32	Cl. 33	Cl. 34	Cl. 35	Cl. 36
1881	29	18	89	30	26	106	320	31	188
1882	16	22	104	21	34	107	346	25	154
1883	27	17	99	31	46	121	357	27	125
1884	20	24	101	40	35	111	456	51	145
1885	29	15	123	56	49	105	464	59	147
1886	25	28	143	35	41	164	464	74	179
1887	27	22	151	49	46	140	413	84	152
1888	25	13	171	28	41	144	492	83	152
1889	27	18	201	50	57	166	569	80	188
1890	25	29	215	48	39	173	634	63	190
1891	24	21	232	44	65	159	702	86	215
1892	40	22	209	53	64	139	662	100	220
1893	26	19	249	67	67	182	676	77	265
1894	36	26	271	67	70	160	713	100	291
1895	46	33	315	51	65	117	724	108	221
1896	65	23	331	59	56	138	731	79	214
1897	63	24	370	75	130	124	720	102	223
1898	69	27	367	88	114	130	743	133	191
1899	58	37	404	107	130	146	838	145	236
1900	55	56	453	118	139	143	783	199	240
1901	59	40	535	103	110	151	845	242	312
1902	77	42	562	119	99	180	1013	267	345
1903	70	36	564	145	107	186	1041	273	375
1904	63	58	589	142	115	180	1033	228	385
1905	99	84	642	133	104	217	1036	259	388
1906	115	73	655	117	110	251	1348	323	383
1907	89	98	808	148	107	319	1341	397	449
1908	102	93	896	163	95	371	1586	398	504
1909	118	99	989	166	107	383	1860	434	564
1910	130	103	958	157	110	404	1675	458	503
1911	132	103	1009	208	152	427	1645	427	570
1912	137	112	1024	255	131	367	1532	432	514
1913	166	94	1144	280	131	464	1797	430	554
1914	99	61	901	172	101	362	1258	375	454
1915	78	137	557	108	50	122	438	123	177
1916	91	160	648	126	58	142	510	143	205
1917	90	160	647	126	58	142	509	143	205
1918	111	196	795	155	72	174	626	175	252
1919	127	177	995	156	93	387	2130	265	820
1920	184	210	1336	216	168	548	1925	450	938
1921	171	176	1403	291	166	602	1817	510	769
1922	190	160	1309	293	169	514	1456	397	758
1923	134	158	1123	258	143	375	1024	391	715
1924	150	222	1304	349	188	487	1493	485	683
1925	181	216	1475	390	215	475	1937	570	569
1926	147	259	1619	385	210	613	1920	520	570
1927	180	362	1819	392	241	621	2193	581	587
1928	169	457	1737	370	262	612	2188	558	621
1929	156	556	1660	427	248	629	2235	584	632
1930	173	416	1688	457	295	647	2695	628	844
1931	116	387	1701	315	273	635	2482	537	836
1932	116	204	1650	269	213	575	2292	429	885
1933	109	201	1493	239	180	511	1874	315	790
1934	116	238	1234	209	210	427	1686	284	651
1935	99	241	1259	231	185	394	1653	248	639
1936	109	339	1178	276	204	408	1625	270	643
1937	118	452	1082	303	258	372	1358	273	556
1938	99	348	1058	310	258	337	1278	325	579

Patent applications in Germany (or in the Federal Republic), broken down by classes of the German patent classification, in the years 1881 - 1973

(contd.)

Year	Cl. 28	Cl. 29	Cl. 30	Cl. 31	Cl. 32	Cl. 33	Cl. 34	Cl. 35	Cl. 36
1939	.	.	.	.	.	.	.	.	.
1940	.	.	.	.	.	.	.	.	.
1941	.	.	.	.	.	.	.	.	.
1942	.	.	.	.	.	.	.	.	.
1943	.	.	.	.	.	.	.	.	.
1944	.	.	.	.	.	.	.	.	.
1945	.	.	.	.	.	.	.	.	.
1946	.	.	.	.	.	.	.	.	.
1947	.	.	.	.	.	.	.	.	.
1948	.	.	.	.	.	.	.	.	.
1949	87	268	1900	447	225	614	2422	349	763
1950	69	236	1569	293	171	508	1561	359	562
1951	78	214	1469	332	143	356	1549	416	677
1952	98	231	1549	352	162	398	1789	471	681
1953	99	229	1502	389	164	423	1824	557	741
1954	92	219	1523	377	168	405	1924	608	690
1955	80	248	1326	342	214	326	1494	472	618
1956	61	245	1072	435	248	268	1249	452	561
1957	50	204	1101	375	215	281	1184	475	538
1958	54	194	1014	359	226	281	1210	494	490
1959	80	197	1072	383	223	236	1297	500	511
1960	59	233	944	342	237	269	1264	504	513
1961	62	277	934	357	289	210	1313	437	383
1962	50	248	881	391	298	242	1311	502	470
1963	67	295	922	374	353	231	1382	520	505
1964	56	298	963	416	315	215	1461	506	578
1965	50	311	1086	424	319	192	1447	491	639
1966	49	317	1032	524	381	227	1564	441	636
1967	68	327	1167	735	343	230	1480	498	563
1968	58	340	1253	780	322	256	1293	444	615
1969	63	365	1297	1014	382	275	1224	470	615
1970	61	332	1395	867	324	219	1324	503	559
1971	45	301	1443	926	303	200	1204	496	526
1972	56	258	1481	828	369	197	1385	523	566
1973	46	286	1686	711	359	178	1293	519	559

Patent applications in Germany (or in the Federal Republic), broken down by classes of the German patent classification, in the years 1881 - 1973

Year	Cl. 37	Cl. 38	Cl. 39	Cl. 40	Cl. 41	Cl. 42	Cl. 43	Cl. 44	Cl. 45
1881	142	113	42	54	20	263	6	124	290
1882	132	111	33	38	13	258	7	144	290
1883	149	89	28	68	21	270	3	176	278
1884	171	113	29	75	12	293	10	153	271
1885	182	131	23	61	18	312	9	163	278
1886	232	126	31	77	35	363	6	151	314
1887	227	137	28	68	28	392	6	238	329
1888	196	145	33	75	18	351	1	230	328
1889	265	174	49	78	30	394	3	310	408
1890	238	182	46	79	39	389	3	269	379
1891	256	190	63	68	28	390	4	260	484
1892	214	177	60	82	27	435	8	215	473
1893	281	202	71	63	26	442	5	192	527
1894	335	193	80	82	25	473	7	195	519
1895	350	164	51	105	19	544	6	168	494
1896	314	159	90	74	30	517	8	167	503
1897	319	176	97	104	19	594	8	166	493
1898	312	223	101	137	23	751	5	152	543
1899	397	238	113	111	27	730	3	162	581
1900	402	197	123	103	34	570	228	139	630
1901	535	272	156	124	32	726	280	169	684
1902	635	252	160	97	35	802	240	205	759
1903	662	247	147	106	48	956	294	216	814
1904	713	252	130	104	23	995	264	190	855
1905	682	287	135	153	51	1048	250	220	894
1906	742	289	203	143	38	1233	305	230	1037
1907	917	306	194	146	44	1332	378	295	1149
1908	1052	295	151	129	57	1312	385	379	1364
1909	1240	365	193	147	56	1466	350	646	1607
1910	1182	358	263	215	61	1465	339	605	1741
1911	1113	361	272	194	68	1523	376	579	1727
1912	1255	357	265	275	89	1646	347	551	1648
1913	1308	417	276	261	72	1704	363	660	1747
1914	883	252	181	176	84	1354	311	382	1219
1915	407	137	134	110	23	713	88	189	565
1916	473	160	156	128	27	829	103	220	658
1917	473	159	156	128	27	829	103	220	657
1918	581	196	192	158	33	1018	126	270	808
1919	1353	318	178	113	38	1521	250	966	1644
1920	1046	398	289	226	56	1875	261	1093	1836
1921	1060	515	291	239	64	2193	307	1054	2080
1922	759	422	302	208	44	2230	269	832	1949
1923	599	347	303	200	39	1963	200	569	1534
1924	881	498	368	336	61	2259	223	614	1967
1925	978	548	504	331	66	2478	323	579	2292
1926	975	523	455	409	79	2483	474	563	2103
1927	1109	571	554	405	80	2878	575	533	2290
1928	1187	562	751	435	68	3312	670	524	2384
1929	1359	576	800	442	65	3589	648	614	2183
1930	1517	538	826	522	77	3920	704	574	2212
1931	1305	397	807	493	72	3486	665	574	1859
1932	993	339	725	358	53	2775	624	535	1515
1933	815	285	621	368	43	2368	474	445	1382
1934	735	290	708	298	42	2204	471	370	1148
1935	776	303	765	344	50	2165	450	305	1252
1936	856	313	757	399	55	2612	378	299	1273
1937	980	341	878	428	52	2736	371	259	1378
1938	1043	335	908	505	29	2741	297	266	1270

Patent applications in Germany (or in the Federal Republic), broken down by classes of the German patent classification, in the years 1881 - 1973

(contd.)

Year	Cl. 37	Cl. 38	Cl. 39	Cl. 40	Cl. 41	Cl. 42	Cl. 43	Cl. 44	Cl. 45
1939	.	.	.	.	.	.	.	.	.
1940	.	.	.	.	.	.	.	.	.
1941	.	.	.	.	.	.	.	.	.
1942	.	.	.	.	.	.	.	.	.
1943	.	.	.	.	.	.	.	.	.
1944	.	.	.	.	.	.	.	.	.
1945	.	.	.	.	.	.	.	.	.
1946	.	.	.	.	.	.	.	.	.
1947	.	.	.	.	.	.	.	.	.
1948	.	.	.	.	.	.	.	.	.
1949	2886	548	1344	333	25	2885	149	499	2432
1950	1381	536	1334	290	31	2864	482	301	1641
1951	1349	587	1251	316	41	3015	387	341	1594
1952	1467	567	1296	328	37	3261	310	336	1709
1953	1671	507	1394	358	49	3208	316	341	1700
1954	1720	475	1602	394	54	3218	326	303	1586
1955	1422	356	1823	331	31	3079	372	238	1277
1956	1303	374	2105	374	31	3121	377	231	1291
1957	1364	365	2167	355	31	2984	399	225	1255
1958	1381	365	2230	350	18	3451	394	181	1263
1959	1403	361	2541	376	25	3450	462	185	1330
1960	1463	298	2571	328	10	3566	498	203	1315
1961	1510	293	3030	347	17	3551	509	207	1267
1962	1744	298	3340	329	22	3331	556	229	1202
1963	1915	276	3482	311	10	3542	555	261	1261
1964	1918	256	3778	427	33	3835	558	301	1449
1965	1957	289	3633	440	34	4106	618	293	1373
1966	1882	246	3618	511	34	3988	519	285	1548
1967	1858	247	3766	505	31	4454	260	291	1544
1968	1752	196	3514	435	31	4484	247	253	1397
1969	1753	197	3665	432	31	5099	307	352	1348
1970	1811	160	3775	497	32	5431	322	284	1231
1971	1931	188	3626	525	36	5378	270	278	1022
1972	2089	175	3621	438	22	5313	303	261	998
1973	2103	220	3329	429	26	5185	324	264	966



Patent applications in Germany (or in the Federal Republic), broken down by classes of the German patent classification, in the years 1881 - 1973

Year	Cl. 46	Cl. 47	Cl. 48	Cl. 49	Cl. 50	Cl. 51	Cl. 52	Cl. 53	Cl. 54
1881	97	202	29	164	120	106	105	53	72
1882	97	228	26	215	115	87	156	57	70
1883	130	257	23	229	114	113	160	57	56
1884	100	308	12	249	162	132	149	57	77
1885	107	395	27	285	166	167	157	72	70
1886	143	389	24	306	149	208	156	76	96
1887	159	370	28	300	129	182	166	67	105
1888	192	331	32	324	144	170	111	79	98
1889	175	430	25	355	150	190	104	92	114
1890	170	404	22	373	160	184	105	113	140
1891	209	482	36	440	177	218	105	110	120
1892	192	510	40	503	146	222	87	136	124
1893	197	489	62	487	176	217	93	185	145
1894	200	508	57	496	172	244	115	197	149
1895	218	460	40	486	163	190	105	183	145
1896	268	490	54	482	151	196	100	219	151
1897	281	562	32	601	127	208	151	265	154
1898	318	607	48	686	173	200	138	347	174
1899	470	747	61	797	132	197	103	333	176
1900	504	751	76	547	140	196	143	323	195
1901	533	926	77	594	160	195	176	333	252
1902	606	1070	63	598	181	229	181	339	281
1903	785	1076	56	566	201	264	193	307	306
1904	803	1114	66	529	210	214	198	313	332
1905	853	1175	62	556	182	241	186	389	379
1906	980	1419	87	591	165	281	189	348	439
1907	963	1605	123	660	227	282	206	339	470
1908	908	1594	144	827	206	283	238	393	560
1909	1009	1578	93	831	261	263	285	393	572
1910	1215	1715	118	820	263	264	298	414	637
1911	1439	1615	135	795	305	262	300	437	548
1912	1606	1557	133	801	299	272	327	449	609
1913	1620	1682	136	818	324	271	352	513	718
1914	1208	1278	124	689	221	208	288	389	474
1915	753	820	71	427	96	60	98	513	194
1916	876	954	83	496	112	69	114	596	225
1917	876	954	83	496	112	69	114	596	225
1918	1076	1172	102	610	138	85	140	732	276
1919	1615	1739	81	1042	211	215	193	635	496
1920	2298	2008	116	1287	205	339	333	551	673
1921	2260	2097	119	1335	283	455	284	541	822
1922	2321	1725	124	1120	316	323	268	409	675
1923	2241	1643	138	947	297	277	214	344	556
1924	2373	1954	185	1231	345	257	293	455	786
1925	2191	2095	185	1260	376	295	288	523	1224
1926	2105	2056	259	1051	337	306	297	521	1105
1927	2067	2103	327	1085	325	290	286	609	1142
1928	2216	2080	337	1106	355	351	296	595	1277
1929	2215	2319	295	1136	342	289	281	592	1237
1930	2440	2291	296	1212	362	288	294	655	1203
1931	2304	2137	270	1074	359	232	317	643	1155
1932	1999	1799	238	927	304	255	307	748	1035
1933	1869	1739	203	727	267	183	276	663	834
1934	1780	1736	257	798	279	118	260	606	768
1935	1806	1885	284	847	281	129	213	592	605
1936	2022	2026	334	951	280	150	222	583	660
1937	2142	2148	445	1026	311	168	199	663	573
1938	2036	2111	370	1162	296	122	182	588	507

H. V. KARLEBYE IN KOPENHAGEN.

Vorrichtung an Tabackspfeifen und an Cigarrenspitzen zur Abkühlung des Rauches und  
Abscheidung des Tabackssaftes.

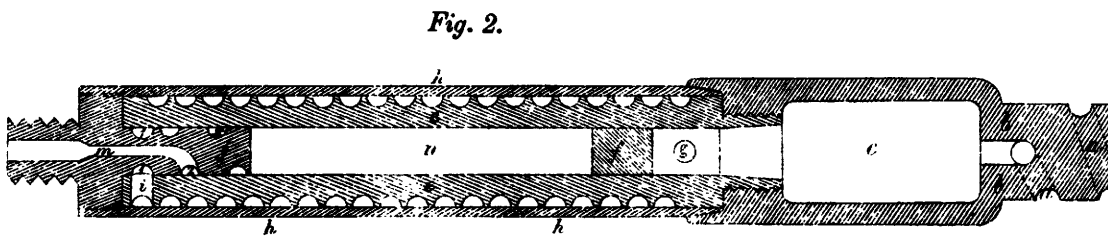
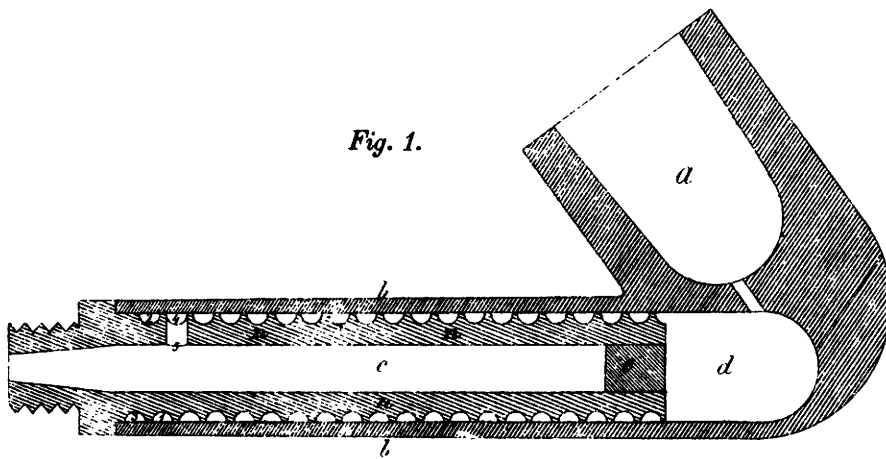

Zu der Patentschrift

**№ 172.**

PHOTOGR. DRUCK DER KÖNIGL. PREUSS. STAATSDRUCKEREI.

G. DAIMLER IN CANNSTATT.

Fahrzeug mit Gas- bzw. Petroleum-Kraftmaschine.

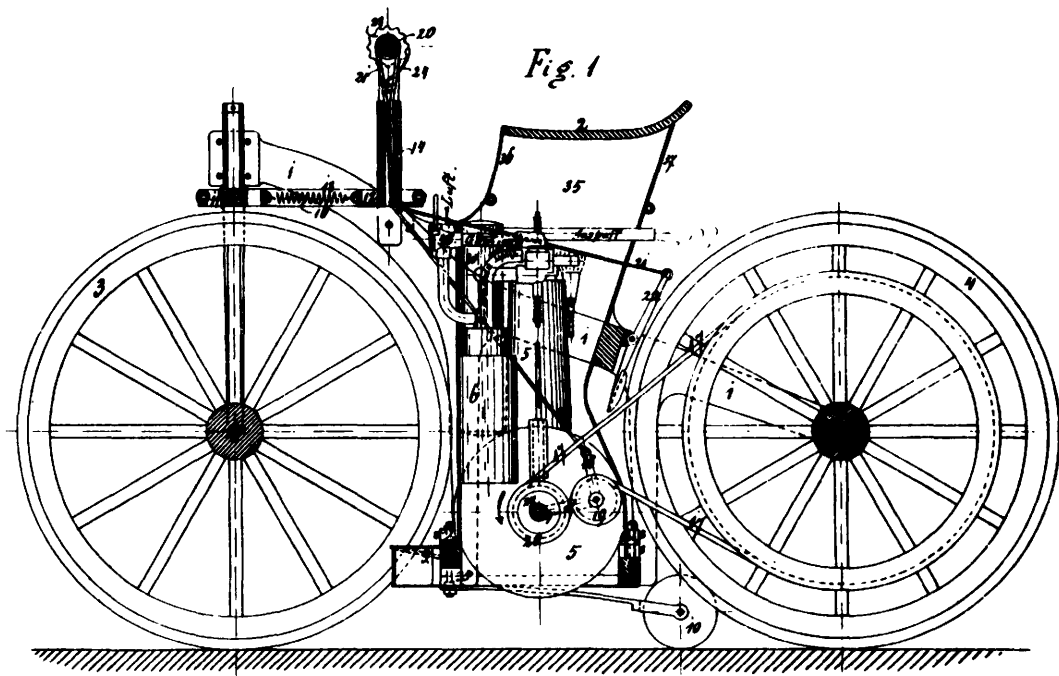

Patent applications in Germany (or in the Federal Republic), broken down by classes of the German patent classification, in the years 1881 - 1973

(contd.)

Year	Cl. 46	Cl. 47	Cl. 48	Cl. 49	Cl. 50	Cl. 51	Cl. 52	Cl. 53	Cl. 54
1939	.	.	.	.	.	.	.	.	.
1940	.	.	.	.	.	.	.	.	.
1941	.	.	.	.	.	.	.	.	.
1942	.	.	.	.	.	.	.	.	.
1943	.	.	.	.	.	.	.	.	.
1944	.	.	.	.	.	.	.	.	.
1945	.	.	.	.	.	.	.	.	.
1946	.	.	.	.	.	.	.	.	.
1947	.	.	.	.	.	.	.	.	.
1948	.	.	.	.	.	.	.	.	.
1949	1460	2142	282	1105	411	183	275	930	490
1950	1646	2037	382	1083	415	117	286	534	557
1951	1498	2124	363	1170	497	120	274	490	529
1952	1433	2437	372	1293	459	123	246	507	544
1953	1472	2616	398	1363	443	128	241	490	577
1954	1368	2672	411	1289	377	119	268	426	534
1955	1242	2327	398	1113	331	104	243	429	434
1956	1127	2313	435	1084	312	90	234	342	370
1957	1098	2451	399	1057	283	97	204	316	338
1958	1084	2731	466	1097	328	83	200	320	371
1959	1139	2831	460	1127	329	74	192	356	377
1960	1288	2923	487	1025	348	81	175	346	342
1961	1340	3098	482	1032	354	71	177	326	317
1962	1359	3643	509	1114	311	70	164	302	410
1963	1259	3652	502	1203	321	75	174	299	373
1964	1247	3608	616	1205	356	82	174	301	416
1965	1411	3470	672	1254	329	86	188	384	394
1966	1309	3714	607	1225	368	104	177	436	395
1967	1160	3796	589	1241	382	85	161	373	395
1968	1014	3628	607	1184	340	103	188	398	327
1969	1055	2974	559	1207	305	84	138	440	266
1970	1039	3034	544	1245	304	128	160	355	305
1971	1102	3220	531	1276	298	91	144	389	311
1972	1125	3542	563	1352	279	85	149	341	333
1973	1275	3580	596	1265	322	95	144	402	308

Patent applications in Germany (or in the Federal Republic), broken down by classes of the German patent classification, in the years 1881 - 1973

Year	Cl. 55	Cl. 56	Cl. 57	Cl. 58	Cl. 59	Cl. 60	Cl. 61	Cl. 62	Cl. 63
1881	59	14	21	36	93	11	31	4	115
1882	86	25	22	42	104	20	69	8	123
1883	98	23	28	38	115	14	42	1	116
1884	98	14	39	46	105	20	30	4	127
1885	73	15	39	43	110	25	48	8	144
1886	97	13	34	50	101	20	35	7	156
1887	77	22	52	41	92	21	33	8	200
1888	78	17	57	34	85	19	45	.	216
1889	83	34	107	33	70	20	53	5	257
1890	91	40	105	23	62	23	34	5	241
1891	97	37	116	22	87	24	52	4	303
1892	74	31	107	39	95	22	53	7	405
1893	84	39	108	32	106	24	62	8	593
1894	63	42	113	35	120	28	71	5	610
1895	92	40	128	30	93	24	48	4	727
1896	91	27	175	33	107	35	56	1	1382
1897	96	31	175	66	96	32	48	2	1897
1898	131	36	205	69	129	43	50	3	1804
1899	133	32	256	68	114	65	82	4	1356
1900	149	59	269	47	135	49	108	.	1000
1901	180	48	338	39	174	49	75	.	933
1902	158	76	317	39	203	70	105	.	933
1903	172	94	383	63	213	61	117	.	976
1904	152	81	355	50	176	58	87	.	1076
1905	153	61	361	54	179	39	82	.	1430
1906	164	85	414	61	183	43	97	.	1921
1907	184	73	418	57	179	52	94	.	2032
1908	216	61	443	80	235	55	100	.	1844
1909	278	86	402	73	232	53	107	.	1853
1910	232	101	387	73	223	65	118	.	1911
1911	288	85	459	85	265	45	147	.	2185
1912	250	75	496	69	242	54	93	.	2186
1913	238	70	600	72	208	53	95	.	2481
1914	187	47	428	62	173	31	87	.	1600
1915	155	26	208	31	96	17	84	.	1261
1916	180	30	242	36	112	20	98	.	1467
1917	180	30	242	36	112	20	98	.	1466
1918	221	37	298	45	137	26	120	.	1801
1919	190	22	670	73	204	38	69	.	1901
1920	234	28	1012	57	245	35	82	.	2612
1921	253	19	1039	72	294	59	137	.	2974
1922	322	19	932	59	284	40	138	.	2929
1923	220	13	820	84	288	46	128	.	2688
1924	282	29	913	74	313	44	134	189	3591
1925	330	41	966	76	355	37	245	492	4266
1926	407	45	875	63	334	18	255	601	3670
1927	439	68	1037	58	344	32	246	602	3780
1928	441	64	1249	74	310	36	244	786	3963
1929	482	47	1538	86	391	30	223	807	3824
1930	446	51	1764	77	384	33	243	711	3972
1931	429	30	1748	67	356	31	230	657	3632
1932	330	31	1674	55	282	30	250	578	3169
1933	289	39	1632	72	224	20	385	649	2947
1934	284	26	1236	56	240	19	332	760	3104
1935	256	31	1309	56	227	15	386	888	3093
1936	292	35	1341	70	252	16	404	994	3335
1937	368	42	1259	61	222	10	348	1145	3062
1938	349	31	1203	83	237	17	382	1164	3043

Patent applications in Germany (or in the Federal Republic), broken down by classes of the German patent classification, in the years 1881 - 1973

Year	Cl. 55	Cl. 56	Cl. 57	Cl. 58	Cl. 59	Cl. 60	Cl. 61	Cl. 62	Cl. 63
1939	.	.	.	.	.	.	.	.	.
1940	.	.	.	.	.	.	.	.	.
1941	.	.	.	.	.	.	.	.	.
1942	.	.	.	.	.	.	.	.	.
1943	.	.	.	.	.	.	.	.	.
1944	.	.	.	.	.	.	.	.	.
1945	.	.	.	.	.	.	.	.	.
1946	.	.	.	.	.	.	.	.	.
1947	.	.	.	.	.	.	.	.	.
1948	.	.	.	.	.	.	.	.	.
1949	190	49	917	112	287	16	118	57	2718
1950	202	22	865	75	339	50	146	90	3113
1951	237	24	797	103	299	65	154	75	3330
1952	209	37	939	112	297	72	179	146	3378
1953	232	44	977	95	310	61	223	172	3609
1954	272	47	1059	99	327	71	183	219	3377
1955	283	29	974	114	316	91	126	291	2929
1956	255	19	980	104	328	97	137	337	2643
1957	290	23	945	84	350	81	95	317	2333
1958	248	23	1064	101	352	88	137	311	2319
1959	325	33	1060	88	369	103	122	347	2221
1960	307	24	1079	92	409	124	126	331	2074
1961	298	31	1032	103	376	127	106	321	2126
1962	280	34	1079	110	411	108	112	388	2164
1963	285	23	1074	104	409	93	104	386	2128
1964	321	15	1257	87	448	124	137	377	2428
1965	298	15	1296	127	482	110	99	404	2491
1966	271	25	1405	144	484	64	100	426	2498
1967	266	32	1434	146	426	68	102	439	2544
1968	294	22	1532	156	400	202	108	452	2594
1969	283	27	1669	126	405	322	86	407	2984
1970	248	27	1956	166	366	350	89	361	2801
1971	243	27	1785	185	376	344	90	300	2937
1972	234	16	1733	228	387	400	107	340	2654
1973	317	25	1677	208	377	399	103	262	2707

Patent applications in Germany (or in the Federal Republic), broken down by classes of the German patent classification, in the years 1881 - 1973

Year	Cl. 64	Cl. 65	Cl. 66	Cl. 67	Cl. 68	Cl. 69	Cl. 70	Cl. 71	Cl. 72
1881	135	64	14	14	90	58	86	73	93
1882	155	65	15	26	98	65	110	63	98
1883	180	88	19	25	99	69	122	70	106
1884	171	84	16	20	117	84	141	69	135
1885	196	82	20	26	174	57	123	86	122
1886	218	89	45	32	144	42	147	86	124
1887	250	85	34	34	142	31	156	106	149
1888	266	87	28	35	172	36	144	103	153
1889	272	90	29	38	184	53	190	117	173
1890	325	115	23	41	193	67	185	116	179
1891	360	117	21	43	212	62	217	144	200
1892	304	125	35	66	253	69	141	112	207
1893	319	144	27	57	273	52	175	135	203
1894	336	149	31	58	231	47	142	123	235
1895	328	203	26	49	267	32	182	137	199
1896	390	173	21	61	236	39	154	157	210
1897	421	184	37	75	285	44	155	170	199
1898	443	240	36	90	323	38	145	215	226
1899	392	279	35	85	282	42	160	163	237
1900	335	290	36	77	315	39	174	175	295
1901	475	307	50	90	352	62	147	195	332
1902	438	275	107	94	462	65	190	252	336
1903	494	263	83	132	414	69	200	244	344
1904	501	346	48	132	424	54	211	268	362
1905	554	456	37	116	477	85	222	288	401
1906	607	480	66	119	566	84	253	371	492
1907	596	585	74	191	605	92	256	419	504
1908	692	574	86	191	721	114	343	473	596
1909	670	595	88	187	783	137	439	527	603
1910	703	692	95	231	767	104	422	542	595
1911	633	602	87	244	724	94	461	546	570
1912	639	784	89	215	788	100	420	612	641
1913	643	799	114	297	843	130	513	618	687
1914	395	700	99	192	553	90	348	453	874
1915	2011	464	20	96	231	70	132	527	1236
1916	232	539	23	112	269	82	153	612	1438
1917	232	539	23	112	269	82	153	612	1437
1918	285	662	27	137	330	101	188	752	1766
1919	440	395	65	341	1158	182	564	506	246
1920	464	518	64	399	1377	211	661	717	292
1921	533	584	88	383	1259	193	693	633	333
1922	435	526	79	331	899	190	584	605	253
1923	304	458	67	296	568	130	497	496	229
1924	462	617	99	330	673	136	434	565	301
1925	692	713	140	441	644	153	475	681	279
1926	804	683	181	404	631	177	430	629	357
1927	787	735	233	359	585	203	433	607	361
1928	784	798	170	431	580	189	414	616	383
1929	790	647	199	418	679	177	395	568	345
1930	806	710	196	418	705	210	416	630	453
1931	748	626	247	399	767	250	415	635	522
1932	725	586	179	385	589	279	382	680	539
1933	589	538	155	334	561	236	299	573	729
1934	550	481	163	223	428	231	271	537	819
1935	467	427	135	265	408	189	303	478	1061
1936	512	427	111	252	465	162	263	449	955
1937	448	451	128	270	408	131	316	379	1096
1938	419	411	103	331	418	126	308	408	1070

Patent applications in Germany (or in the Federal Republic), broken down by classes of the German patent classification, in the years 1881 - 1973

(contd.)

Year	Cl. 64	Cl. 65	Cl. 66	Cl. 67	Cl. 68	Cl. 69	Cl. 70	Cl. 71	Cl. 72
1939	.	.	.	.	.	.	.	.	.
1940	.	.	.	.	.	.	.	.	.
1941	.	.	.	.	.	.	.	.	.
1942	.	.	.	.	.	.	.	.	.
1943	.	.	.	.	.	.	.	.	.
1944	.	.	.	.	.	.	.	.	.
1945	.	.	.	.	.	.	.	.	.
1946	.	.	.	.	.	.	.	.	.
1947	.	.	.	.	.	.	.	.	.
1948	.	.	.	.	.	.	.	.	.
1949	492	306	126	291	613	205	746	649	66
1950	483	237	117	281	462	154	477	374	80
1951	449	294	128	328	420	152	346	352	156
1952	485	281	116	329	530	127	392	354	192
1953	471	273	136	408	519	135	389	330	210
1954	383	329	97	409	545	154	359	303	184
1955	395	361	103	283	457	125	302	275	217
1956	354	375	102	287	453	105	292	231	239
1957	376	359	90	342	483	114	252	253	292
1958	341	401	85	312	444	101	215	305	297
1959	383	379	83	263	452	67	222	288	309
1960	394	422	78	279	458	75	173	239	265
1961	359	388	70	266	449	78	155	304	221
1962	353	348	87	274	454	63	203	329	271
1963	410	373	84	268	508	85	145	259	285
1964	404	404	65	286	554	80	187	275	314
1965	353	410	98	314	538	93	218	241	341
1966	330	367	58	358	566	98	221	219	359
1967	371	447	73	306	560	115	191	205	321
1968	369	401	37	267	615	76	169	192	353
1969	346	452	68	271	510	76	169	178	332
1970	278	442	88	301	532	101	163	213	324
1971	292	358	101	268	573	108	174	176	305
1972	306	386	90	273	581	102	170	158	330
1973	294	366	71	299	548	156	124	178	329



Patent applications in Germany (or in the Federal Republic), broken down by classes of the German patent classification, in the years 1881 - 1973

Year	Cl. 73	Cl. 74	Cl. 75	Cl. 76	Cl. 77	Cl. 78	Cl. 79	Cl. 80	Cl. 81
1881	8	24	60	108	130	29	21	114	65
1882	8	32	72	100	139	36	32	117	50
1883	8	30	59	96	111	34	32	123	57
1884	6	31	51	105	104	29	19	141	55
1885	13	32	63	108	142	30	18	128	83
1886	4	34	56	133	148	43	31	166	60
1887	11	43	57	127	183	36	24	171	54
1888	10	59	46	124	163	34	23	129	64
1889	10	65	57	107	273	38	26	168	89
1890	17	78	51	90	272	53	43	203	61
1891	8	61	80	126	272	54	35	240	98
1892	17	65	73	146	239	48	23	260	78
1893	11	94	109	117	233	49	33	285	102
1894	8	90	122	147	271	66	48	280	125
1895	4	89	.	160	288	81	50	283	127
1896	8	113	.	153	257	87	61	336	163
1897	11	121	.	185	256	75	61	343	144
1898	11	112	.	152	257	101	76	387	204
1899	12	117	.	141	248	114	66	440	198
1900	4	144	.	169	264	84	80	537	214
1901	5	216	1	151	306	132	105	482	254
1902	10	202	20	160	404	134	116	520	352
1903	7	186	96	152	404	93	124	537	351
1904	7	249	186	226	368	135	95	569	332
1905	11	302	247	249	378	137	115	588	386
1906	10	296	262	184	506	134	114	569	427
1907	9	342	313	183	642	120	110	626	472
1908	8	406	340	234	1487	132	100	646	613
1909	13	430	345	249	2316	214	111	675	681
1910	15	444	314	228	2233	140	111	731	713
1911	14	425	285	233	1887	128	117	675	677
1912	22	463	289	259	1935	134	126	644	758
1913	16	535	296	323	1927	150	140	751	758
1914	25	413	195	171	1285	139	80	578	613
1915	11	225	65	128	827	214	53	214	312
1916	12	262	76	149	962	249	61	249	363
1917	12	262	76	149	962	249	61	249	363
1918	16	321	93	183	1182	306	75	306	446
1919	26	513	202	118	1124	79	86	683	694
1920	14	688	272	149	1345	141	164	850	768
1921	23	831	324	217	1383	167	160	758	882
1922	19	643	275	265	1378	166	134	776	789
1923	18	563	210	216	1198	120	102	592	717
1924	23	542	301	295	1234	154	164	744	975
1925	19	577	337	372	1153	170	182	876	1226
1926	30	582	352	385	1047	114	186	853	1380
1927	25	611	380	415	997	142	222	1036	1419
1928	25	669	424	429	860	166	243	1041	1547
1929	32	778	413	461	793	146	212	1056	1569
1930	36	850	445	504	922	172	250	1222	1678
1931	34	701	377	419	989	165	337	984	1572
1932	32	583	377	306	979	160	260	766	1288
1933	18	508	328	270	818	125	186	728	1127
1934	19	560	316	257	597	137	195	668	1014
1935	21	472	318	228	582	117	171	649	1072
1936	24	524	287	290	585	125	155	679	1114
1937	14	580	283	331	543	126	144	698	1094
1938	23	560	267	319	511	116	127	750	911

Patent applications in Germany (or in the Federal Republic), broken down by classes of the German patent classification, in the years 1881 - 1973

Year	Cl. 73	Cl. 74	Cl. 75	Cl. 76	Cl. 77	Cl. 78	Cl. 79	Cl. 80	Cl. 81
1939	.	.	.	.	.	.	.	.	.
1940	.	.	.	.	.	.	.	.	.
1941	.	.	.	.	.	.	.	.	.
1942	.	.	.	.	.	.	.	.	.
1943	.	.	.	.	.	.	.	.	.
1944	.	.	.	.	.	.	.	.	.
1945	.	.	.	.	.	.	.	.	.
1946	.	.	.	.	.	.	.	.	.
1947	.	.	.	.	.	.	.	.	.
1948	.	.	.	.	.	.	.	.	.
1949	11	312	327	383	1329	77	107	1305	1134
1950	9	269	290	452	827	44	168	841	1249
1951	13	389	299	510	801	54	123	874	1431
1952	14	474	308	459	865	59	108	867	1604
1953	23	457	319	460	729	71	127	851	1794
1954	24	435	308	432	792	71	144	838	1766
1955	29	364	331	413	569	92	116	852	1606
1956	29	315	327	393	472	79	120	714	1610
1957	31	278	296	353	475	75	143	772	1792
1958	33	266	272	423	469	119	212	682	1730
1959	17	251	326	404	463	142	201	796	1665
1960	21	252	323	409	443	158	181	788	1879
1961	21	242	376	432	451	119	159	843	1797
1962	14	277	352	420	478	119	131	858	2026
1963	31	249	356	464	512	97	166	838	2098
1964	35	252	462	484	531	95	211	985	2187
1965	40	249	495	458	625	115	193	1011	2236
1966	33	263	515	412	711	86	184	927	2451
1967	25	319	514	396	659	111	145	824	2412
1968	31	306	426	357	641	116	185	781	2297
1969	36	294	395	325	663	88	154	767	2415
1970	35	325	432	371	640	87	161	752	2236
1971	59	368	449	439	611	76	177	765	2425
1972	41	415	416	418	795	86	156	839	2512
1973	28	414	365	378	669	118	136	818	2337

Patent applications in Germany (or in the Federal Republic), broken down by classes of the German patent classification, in the years 1881 - 1973

Year	Cl. 82	Cl. 83	Cl. 84	Cl. 85	Cl. 86	Cl. 87	Cl. 88	Cl. 89
1881	42	48	13	140	101	27	39	130
1882	47	55	14	152	95	41	38	145
1883	56	63	13	151	125	29	40	172
1884	89	86	12	156	137	50	23	143
1885	68	91	19	165	158	46	30	128
1886	52	100	15	132	167	33	34	117
1887	49	83	17	134	126	42	31	96
1888	58	84	23	129	165	40	50	109
1889	65	98	28	142	198	40	41	116
1890	53	96	32	138	126	56	49	147
1891	71	103	29	185	173	58	40	117
1892	76	82	24	147	186	53	71	147
1893	92	58	29	206	157	71	64	133
1894	77	69	22	198	162	49	62	129
1895	81	69	19	203	160	47	70	115
1896	95	69	19	212	173	52	74	116
1897	88	76	35	202	205	44	83	123
1898	92	75	29	209	237	57	92	120
1899	124	93	35	186	219	61	79	116
1900	146	87	42	261	198	48	104	100
1901	144	98	36	327	235	82	106	125
1902	180	123	48	329	265	97	102	127
1903	140	133	82	335	284	114	119	122
1904	160	132	101	255	258	125	106	107
1905	152	134	102	267	244	137	102	101
1906	179	142	98	288	261	134	155	123
1907	178	141	101	301	268	181	128	88
1908	209	143	127	363	347	229	157	119
1909	237	145	150	459	343	231	178	113
1910	231	143	146	426	312	260	156	114
1911	234	161	178	401	291	215	162	96
1912	215	153	186	452	346	223	154	108
1913	243	165	190	482	327	245	176	94
1914	180	115	152	344	201	185	117	73
1915	117	38	68	131	68	77	63	41
1916	136	44	79	153	79	89	73	47
1917	136	44	79	153	79	89	73	47
1918	167	54	97	188	97	110	90	58
1919	194	128	122	307	115	366	251	49
1920	238	155	173	262	177	446	404	90
1921	207	178	172	312	253	420	415	97
1922	159	135	181	272	255	325	327	81
1923	176	133	133	180	194	243	272	62
1924	221	170	151	257	242	282	335	85
1925	253	175	204	372	339	345	500	112
1926	262	199	226	422	324	252	326	127
1927	326	439	234	398	339	237	257	131
1928	301	307	257	480	362	281	230	121
1929	311	259	237	575	424	250	180	99
1930	340	295	280	559	435	310	188	105
1931	270	296	278	502	456	215	204	96
1932	214	203	266	411	365	189	184	83
1933	208	156	298	368	297	149	159	86
1934	184	156	245	327	249	126	121	67
1935	215	159	201	323	274	140	129	107
1936	201	144	239	368	267	154	120	77
1937	211	191	182	359	233	136	102	98
1938	160	178	238	296	238	162	137	126

Patent applications in Germany (or in the Federal Republic), broken down by classes of the German patent classification, in the years 1881 - 1973

Year	Cl. 82	Cl. 83	Cl. 84	Cl. 85	Cl. 86	Cl. 87	Cl. 88	Cl. 89
1939	.	.	.	.	.	.	.	.
1940	.	.	.	.	.	.	.	.
1941	.	.	.	.	.	.	.	.
1942	.	.	.	.	.	.	.	.
1943	.	.	.	.	.	.	.	.
1944	.	.	.	.	.	.	.	.
1945	.	.	.	.	.	.	.	.
1946	.	.	.	.	.	.	.	.
1947	.	.	.	.	.	.	.	.
1948	.	.	.	.	.	.	.	.
1949	325	297	173	261	241	352	120	108
1950	266	249	243	333	336	189	100	59
1951	297	254	241	367	329	207	82	67
1952	267	294	257	386	291	238	80	58
1953	268	277	268	408	322	247	116	57
1954	285	265	267	404	253	242	99	74
1955	225	258	279	385	295	233	84	60
1956	211	247	222	328	259	221	62	44
1957	246	243	265	316	218	205	90	55
1958	255	236	268	289	218	221	102	57
1959	264	174	313	344	246	250	89	49
1960	238	190	292	352	232	215	71	63
1961	244	168	271	399	255	195	70	38
1962	249	182	339	397	258	201	56	52
1963	264	190	333	435	224	192	62	41
1964	306	187	377	411	222	223	82	36
1965	298	190	396	468	252	229	63	53
1966	275	211	417	479	247	254	53	39
1967	267	216	414	530	259	213	67	35
1968	253	228	401	520	249	224	57	35
1969	231	242	364	590	226	201	53	49
1970	178	280	380	485	201	189	103	35
1971	209	256	345	511	236	207	74	44
1972	201	275	360	598	230	243	88	37
1973	176	237	383	587	212	249	110	29

R. M. DAELLEN IN HILFDE VON NEUSS.

Entlastetes Dampfventil.

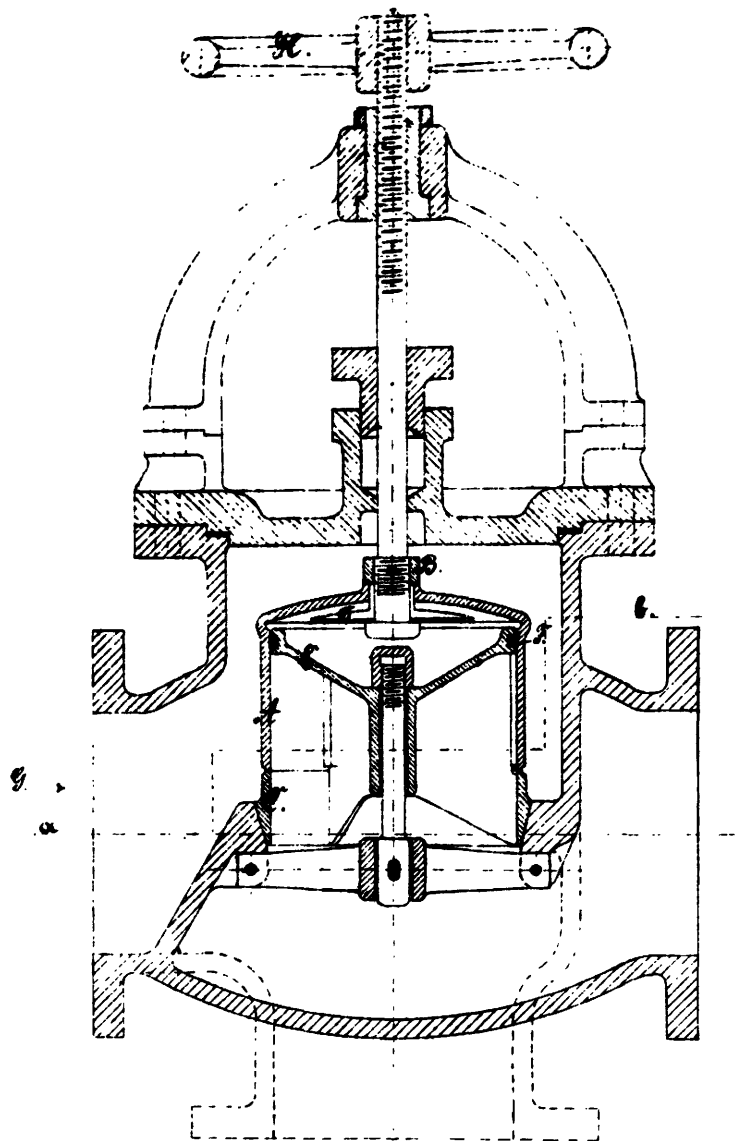

Schnitt a. b.

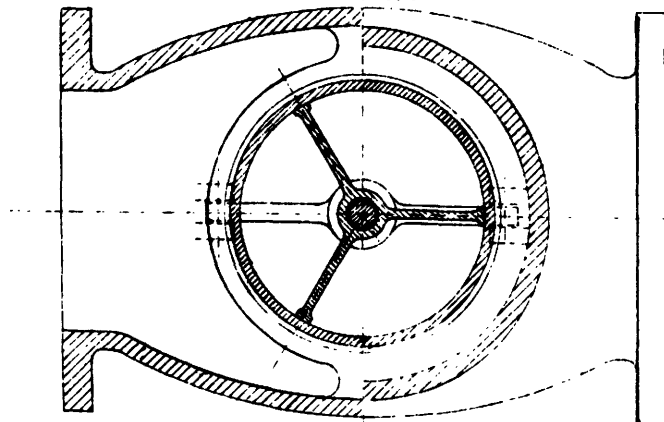

PHOTOG. DRUCK DER KÖNIGL. PREUSS. STAATSDRUCKEREI.

Zu der Patentschrift

№ 48.

W. MOTZ IN BERLIN.  
Dreithellige Riemenschraube.

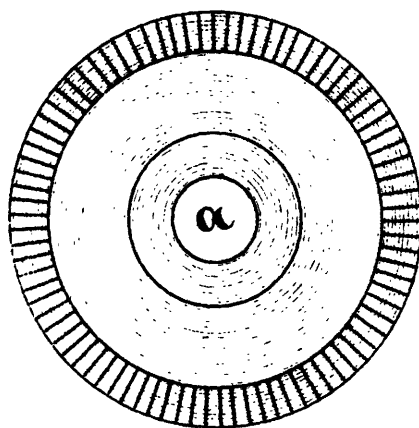
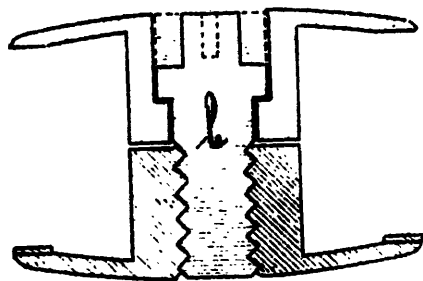

Zu der Patentschrift

№ 82.

PHOTOGR. DRUCK DER KÖNIGL. PREUSS. STAATSDRUCKEREI.



3. Development in the Individual Patent Classes  
in Absolute numbers of Patent Applications  
in Periods of Two Years (from 1882 to 1974)  
and Proportions of Total Patent Applications  
in 1/1000 in Classes 01 - 89



Cl. 1 Preparation of ores, fuels and other minerals, including waste and the residues of combustion

ABSOLUTE NUMBER OF PAT. APPL. IN PERIOD OF 2 YEARS IN THE CLASS 01

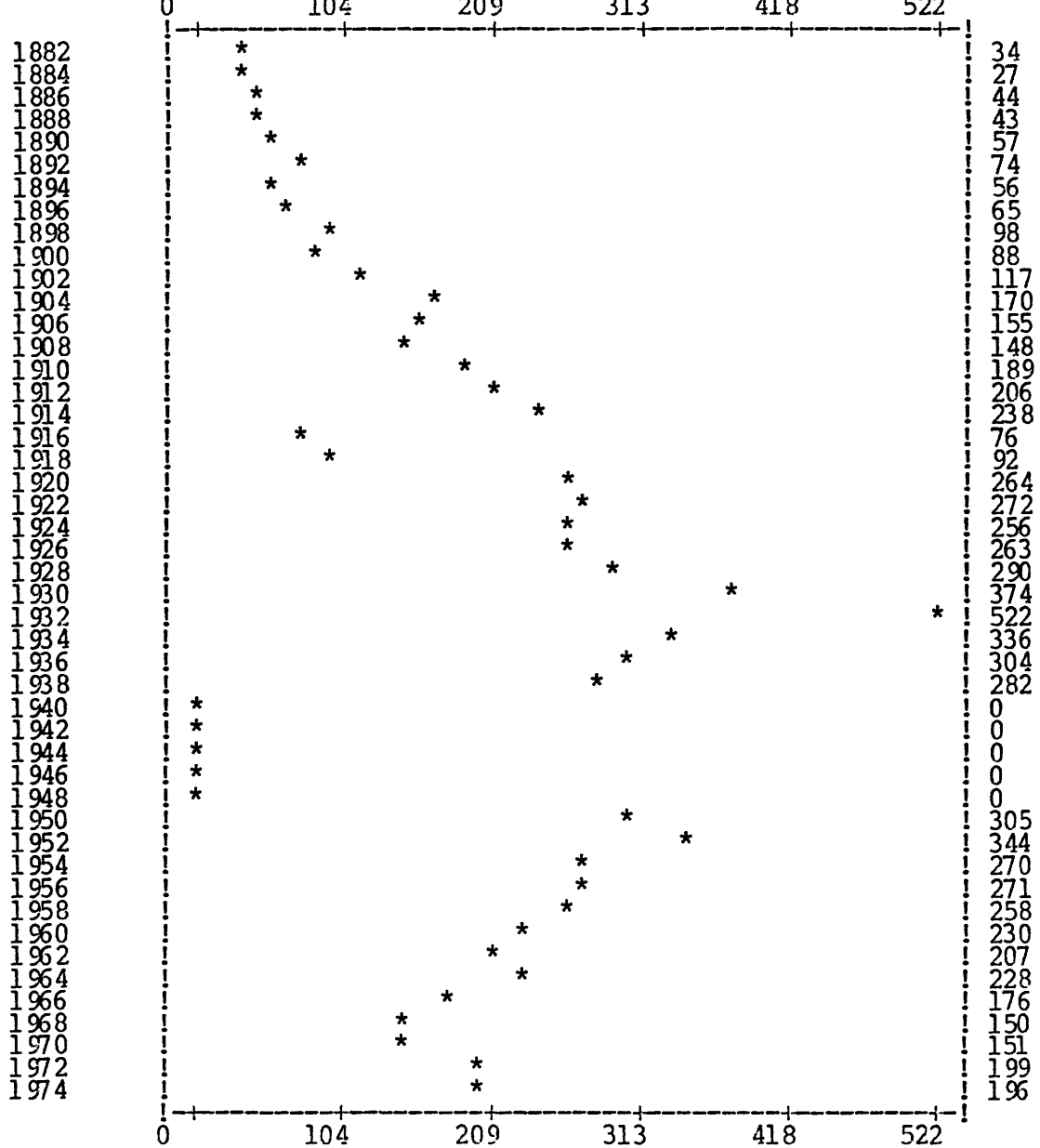

PROPORTION OF TOTAL PAT. APPL. IN 1/1000 IN THE CLASS 01

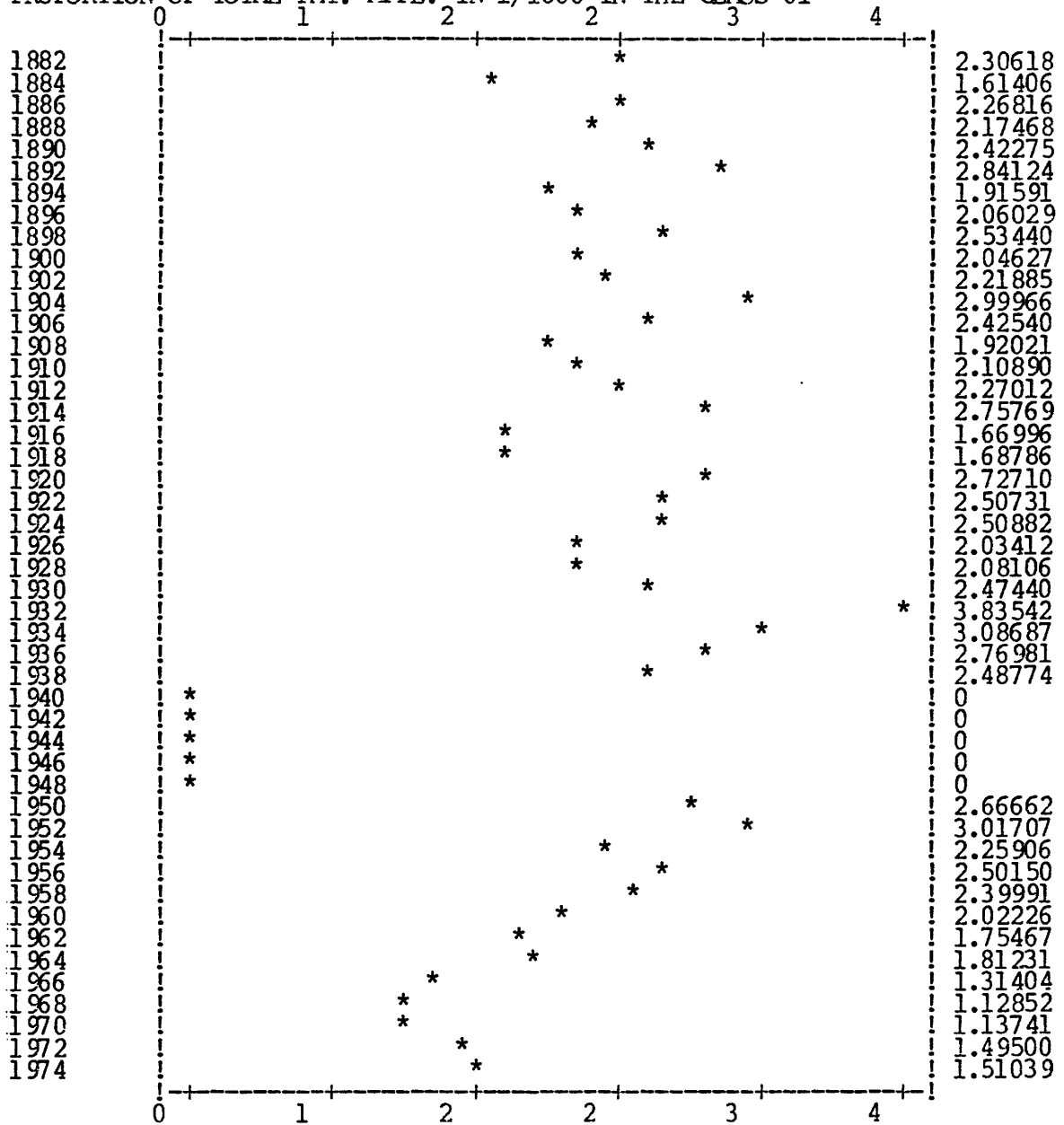

Cl. 2 Baking

ABSOLUTE NUMBER OF PAT. APPL. IN PERIOD OF 2 YEARS IN THE CLASS 02

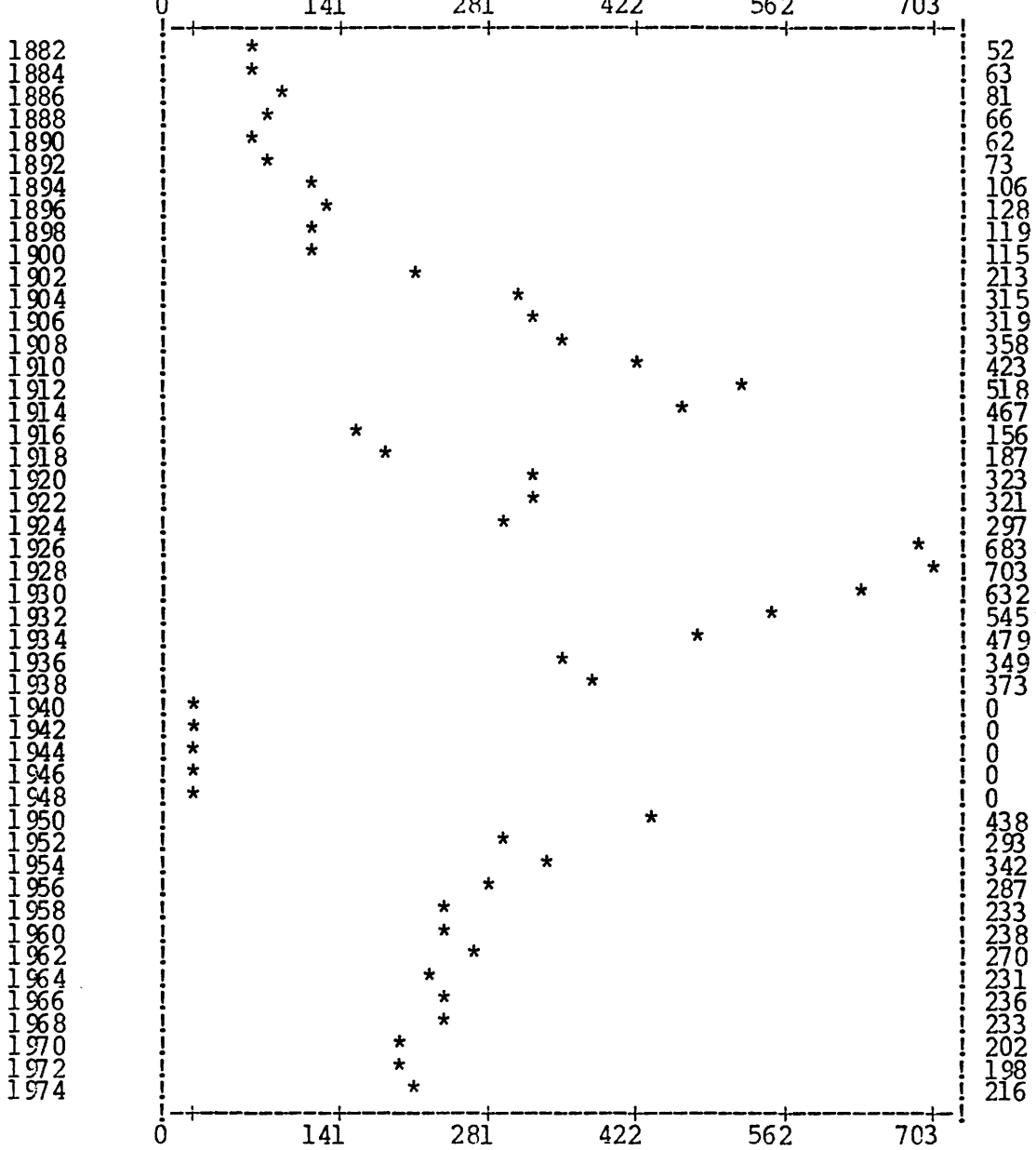

PROPORTION OF TOTAL PAT. APPL. IN 1/1000 IN THE CLASS 02

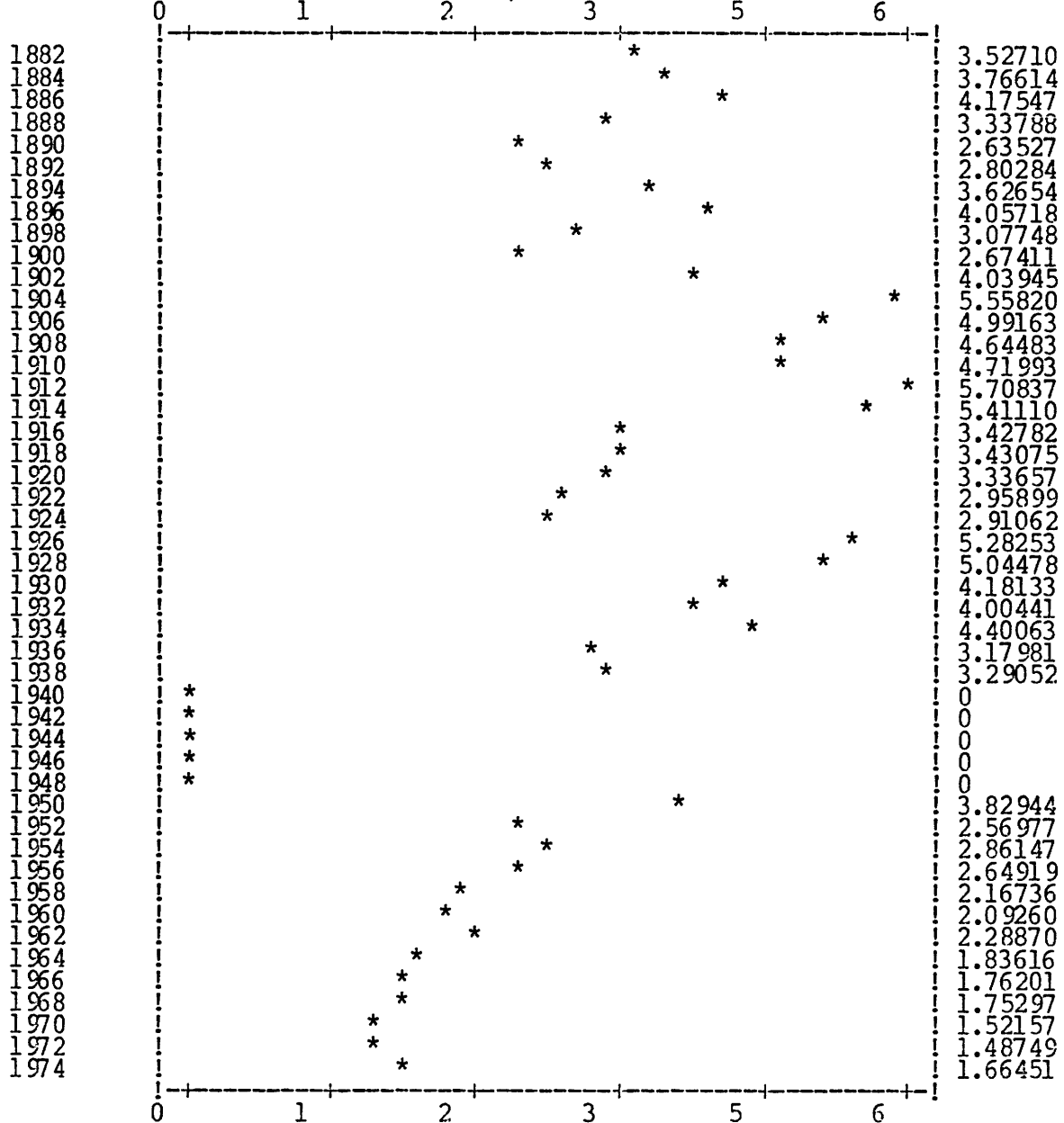

Cl. 3 Wearing apparel

ABSOLUTE NUMBER OF PAT. APPL. IN PERIOD OF 2 YEARS IN THE CLASS 03

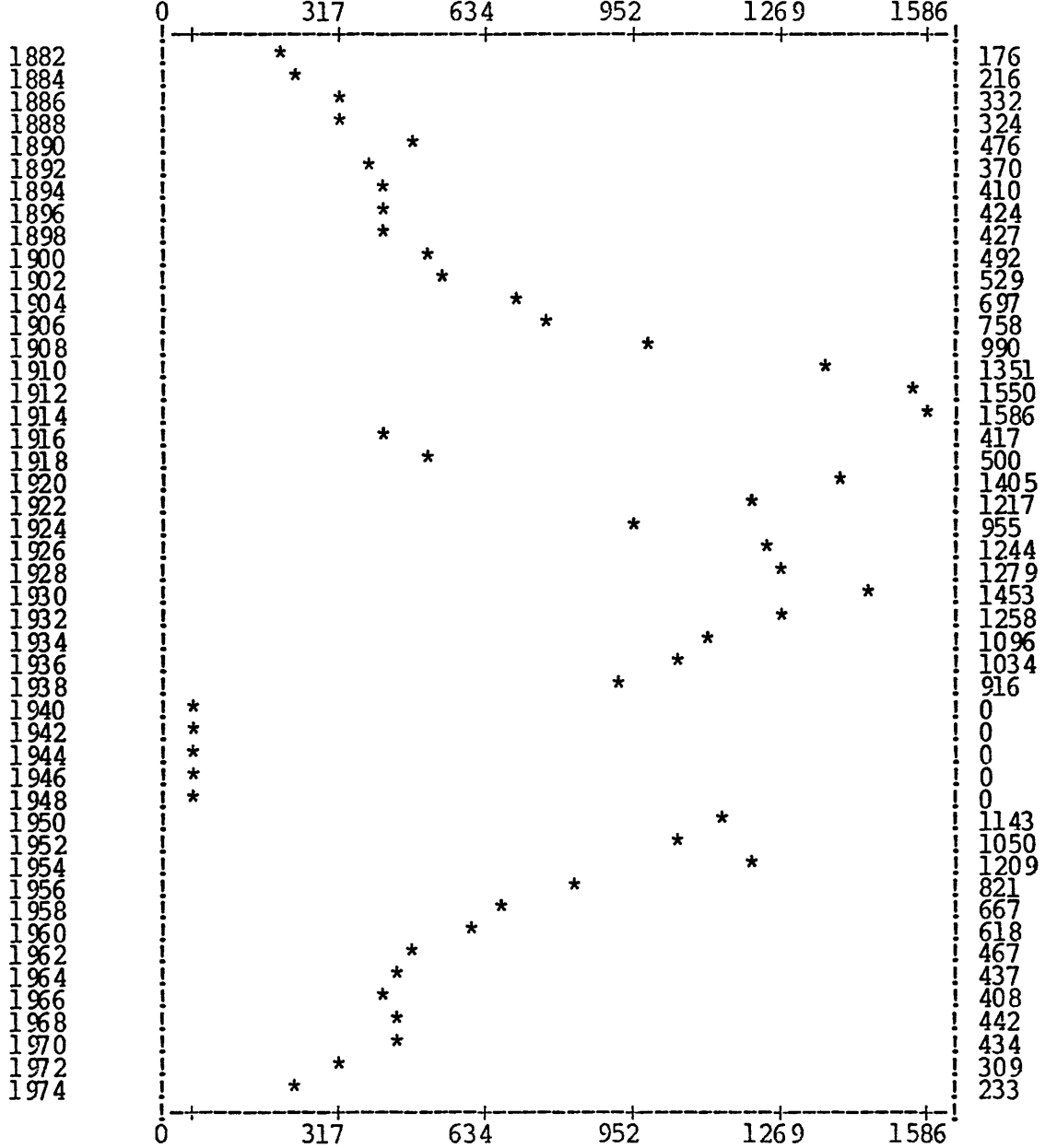

PROPORTION OF TOTAL PAT. APPL. IN 1/1000 IN THE CLASS 03

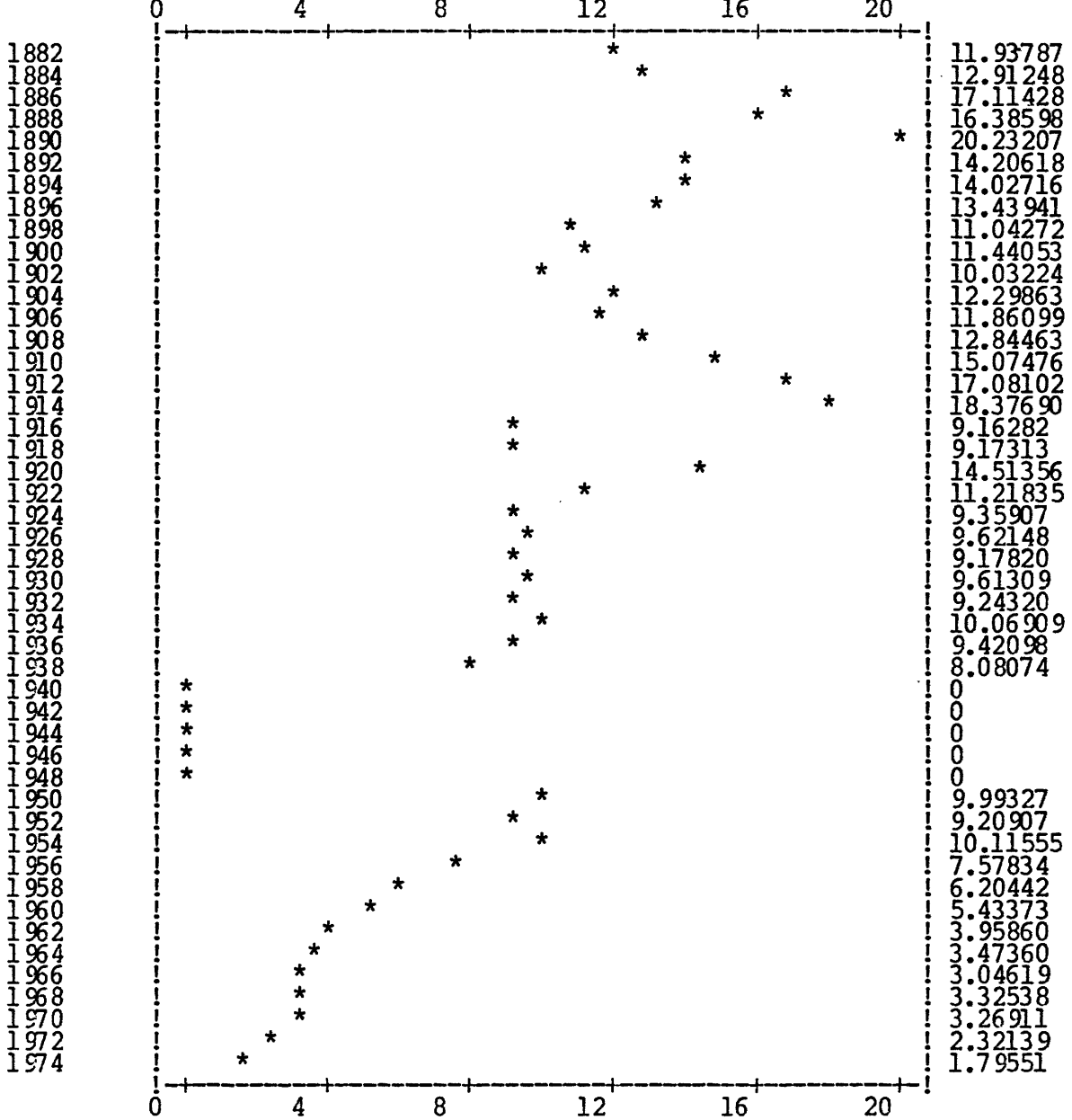

C1. 4 Lighting through fuels and pre-heating torches

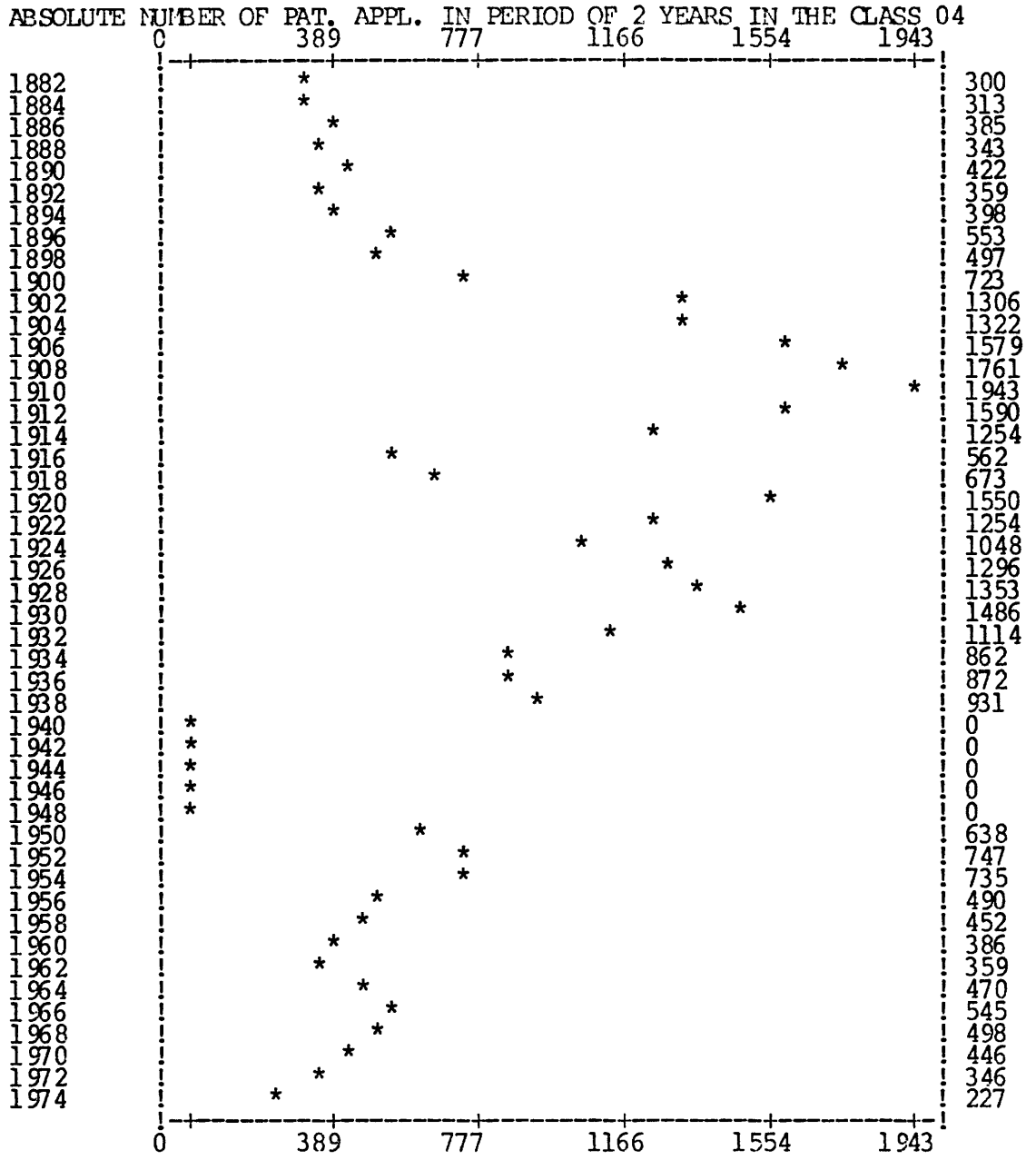

PROPORTION OF TOTAL PAT. APPL. IN 1/1000 IN THE CLASS 04

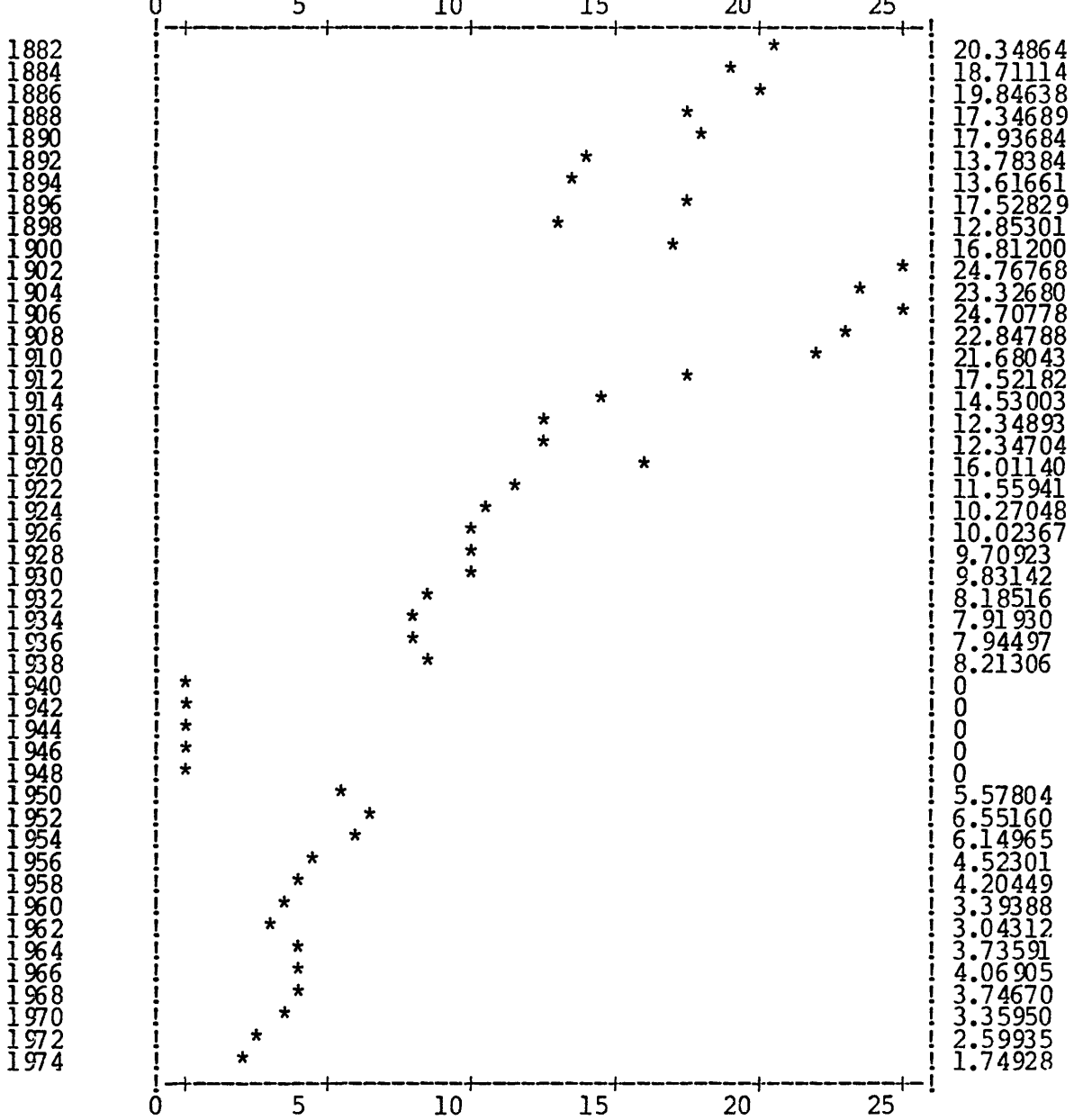



Cl. 5 Mining

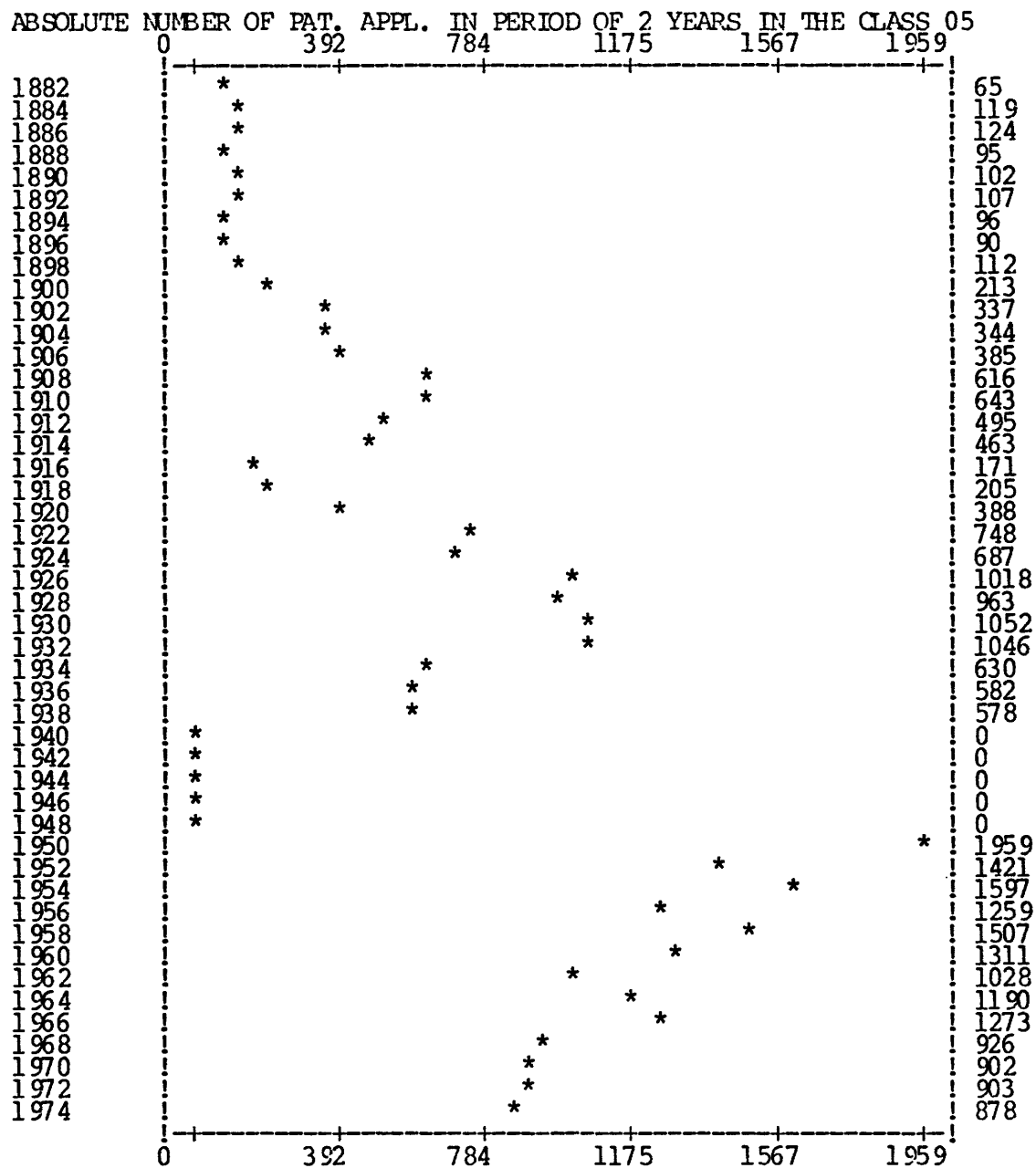

PROPORTION OF TOTAL PAT. APPL. IN 1/1000 IN THE CLASS 05

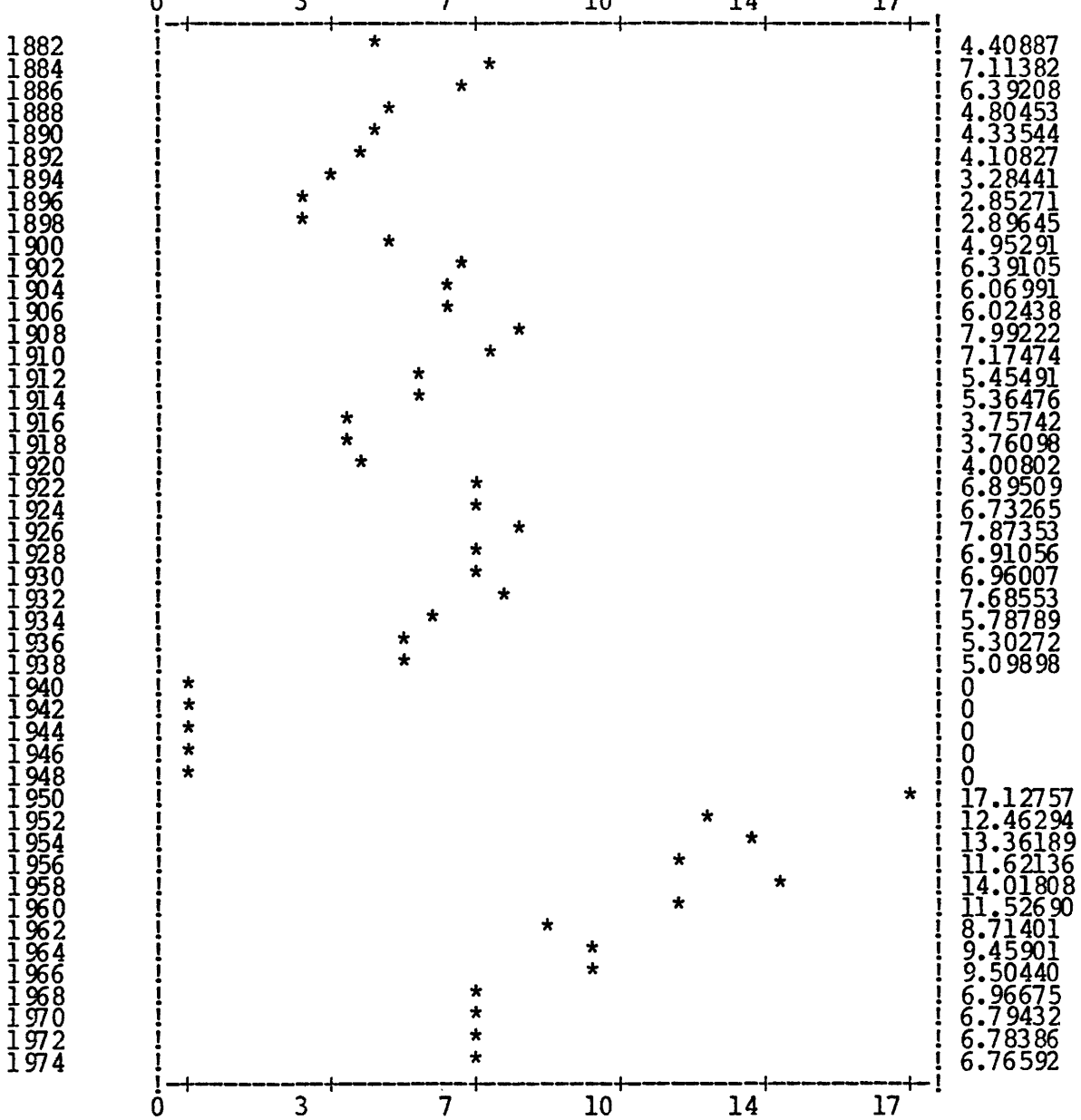

Cl. 6 Zymology : alcohol, spirits, beer, wine, vinegar, yeast and other fermentation agents and products, enzymes

ABSOLUTE NUMBER OF PAT. APPL. IN PERIOD OF 2 YEARS IN THE CLASS 06

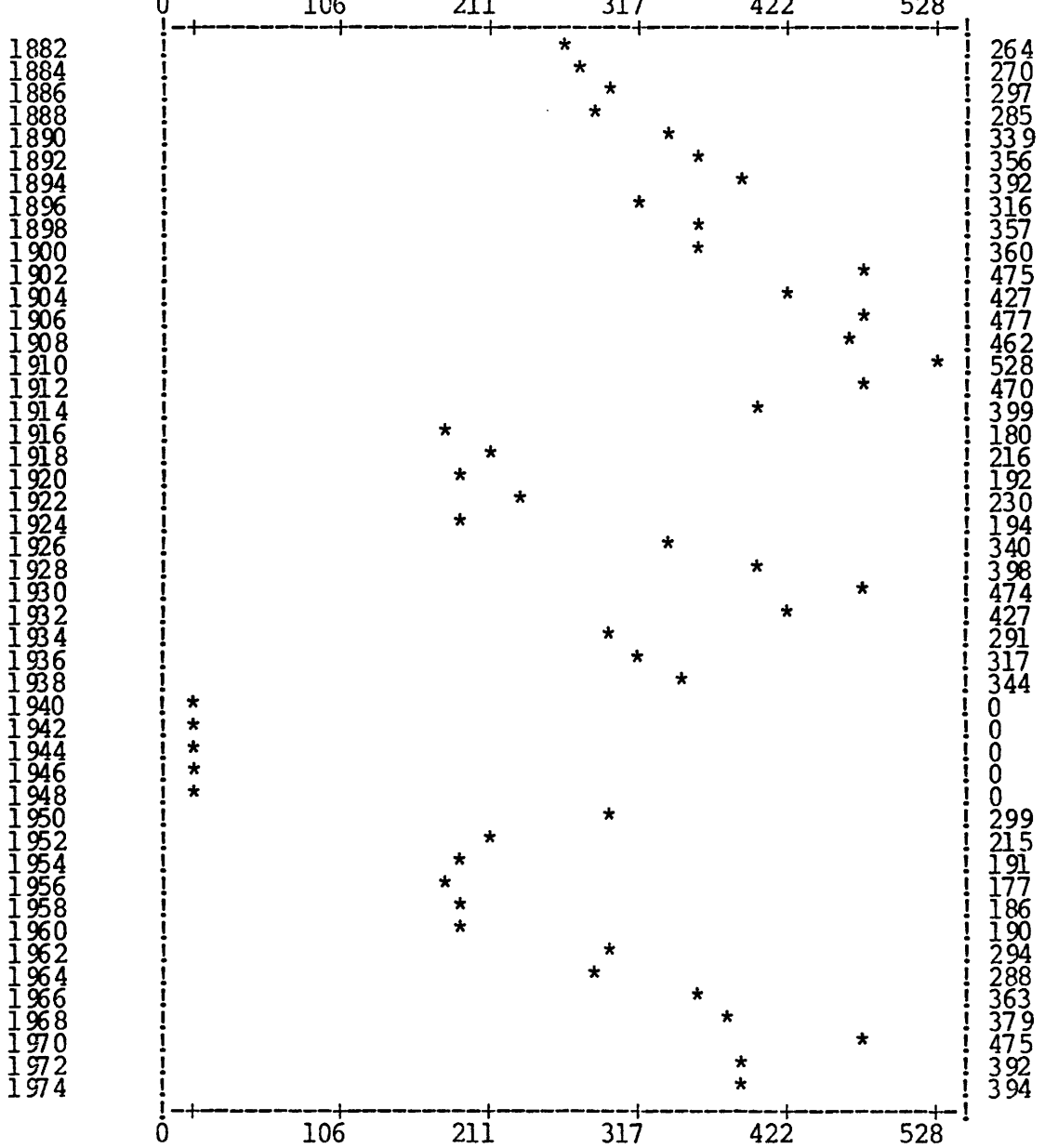

PROPORTION OF TOTAL PAT. APPL. IN 1/1000 IN THE CLASS 06

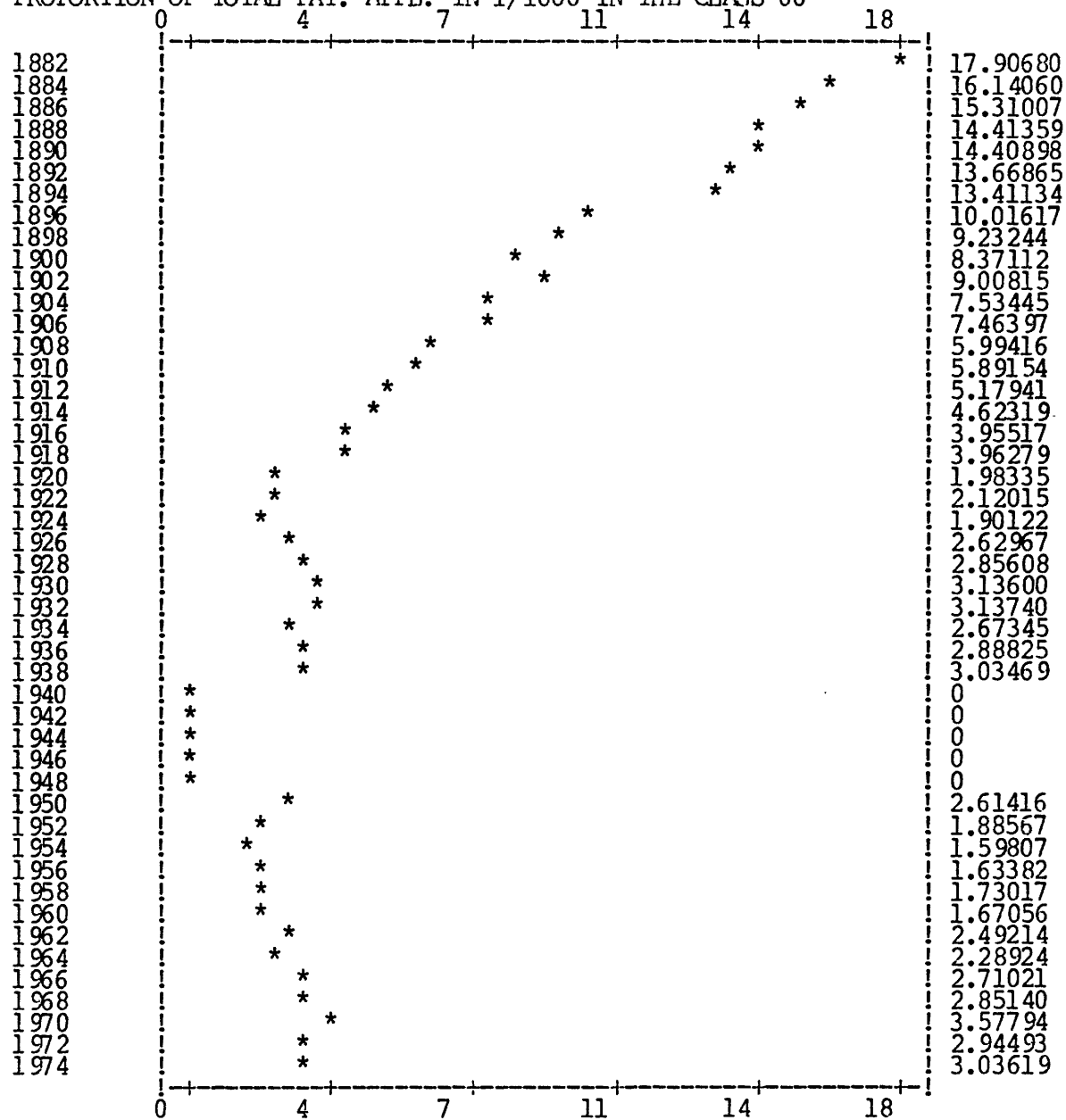

Cl. 7 Mechanical metal working without essentially removing material; punching metal

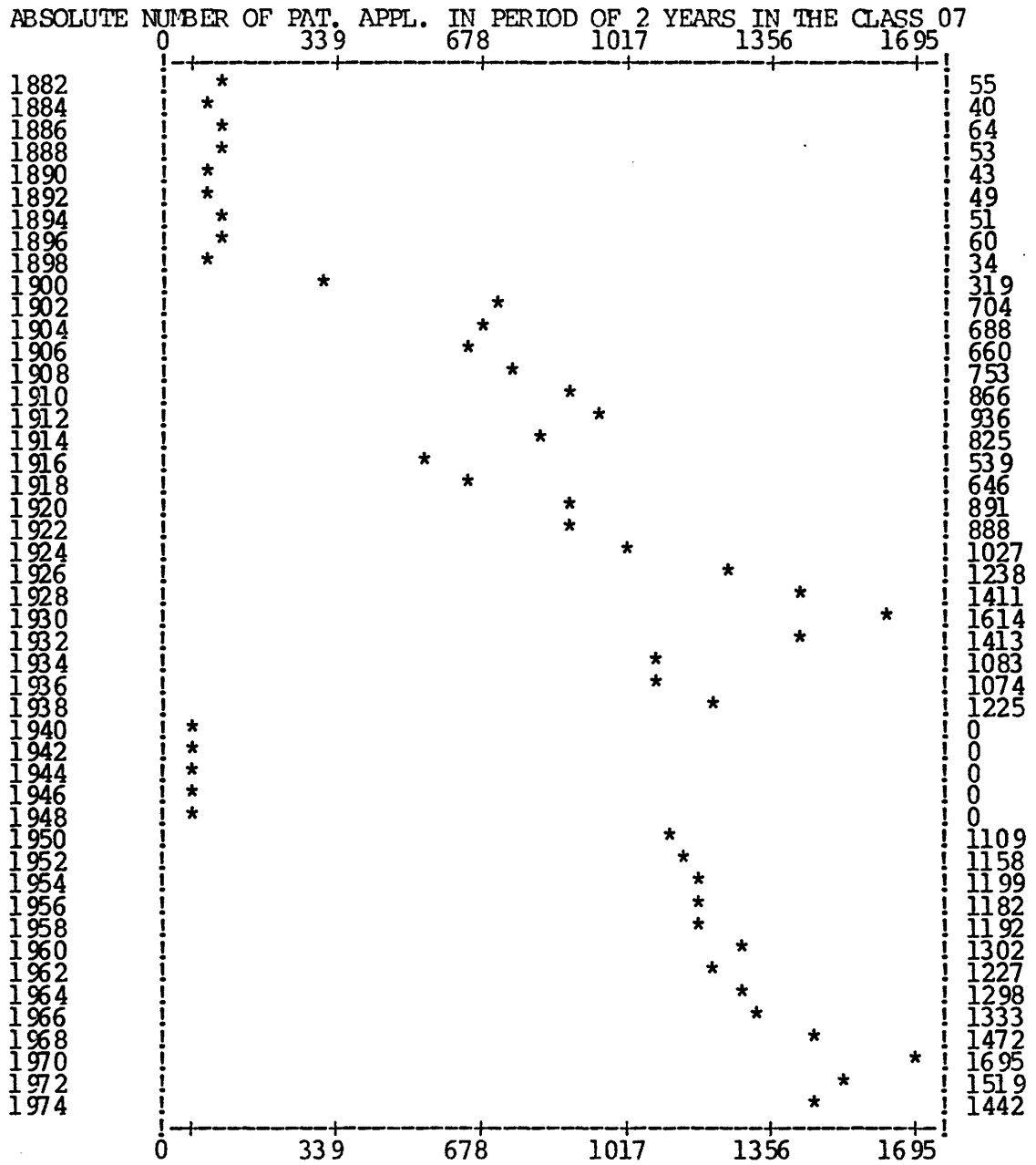

PROPORTION OF TOTAL PAT. APPL. IN 1/1000 IN THE CLASS 07

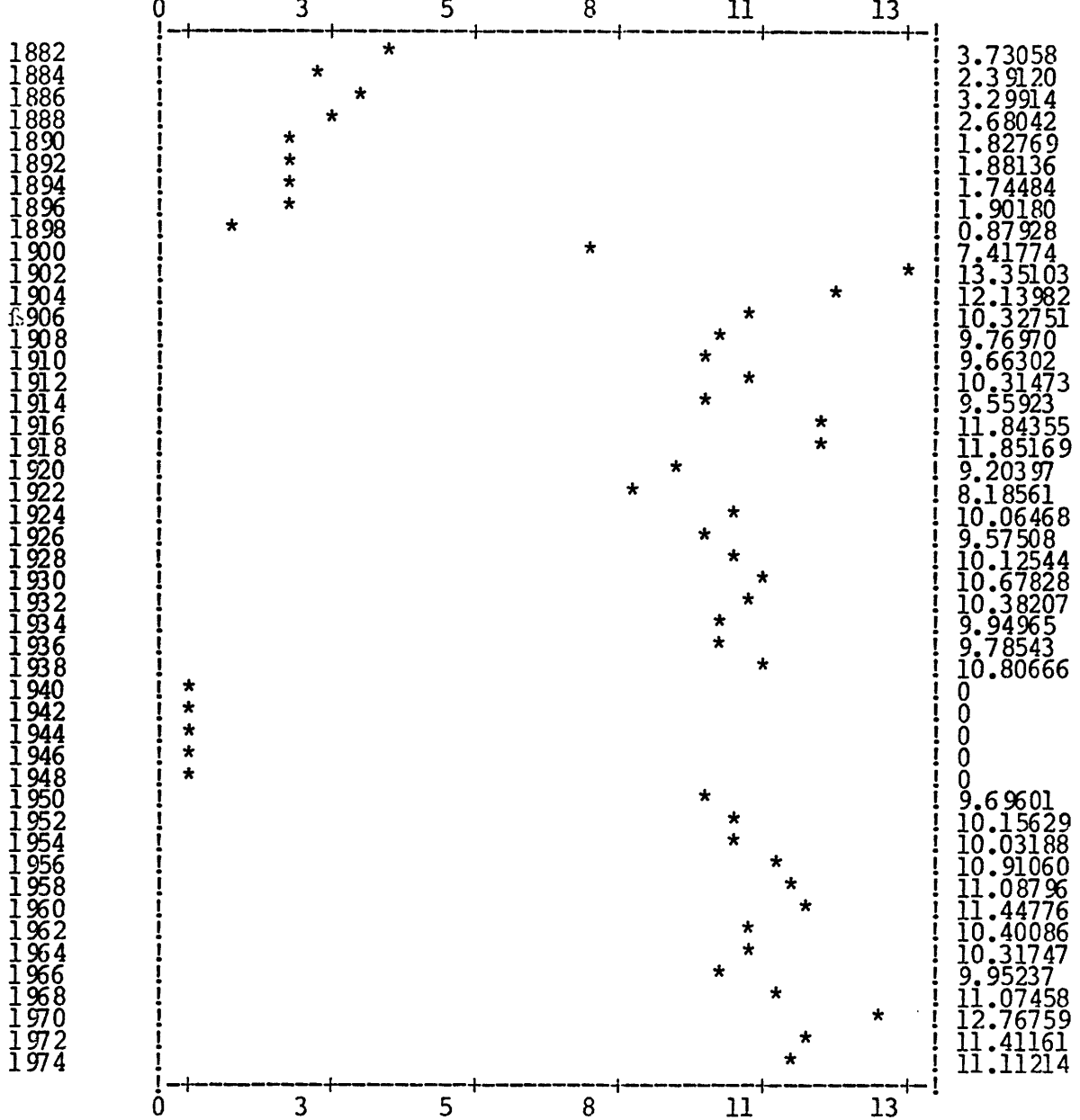

C1. 8 Bleaching, washing, dyeing, printing of cloth and tapestry and finishing

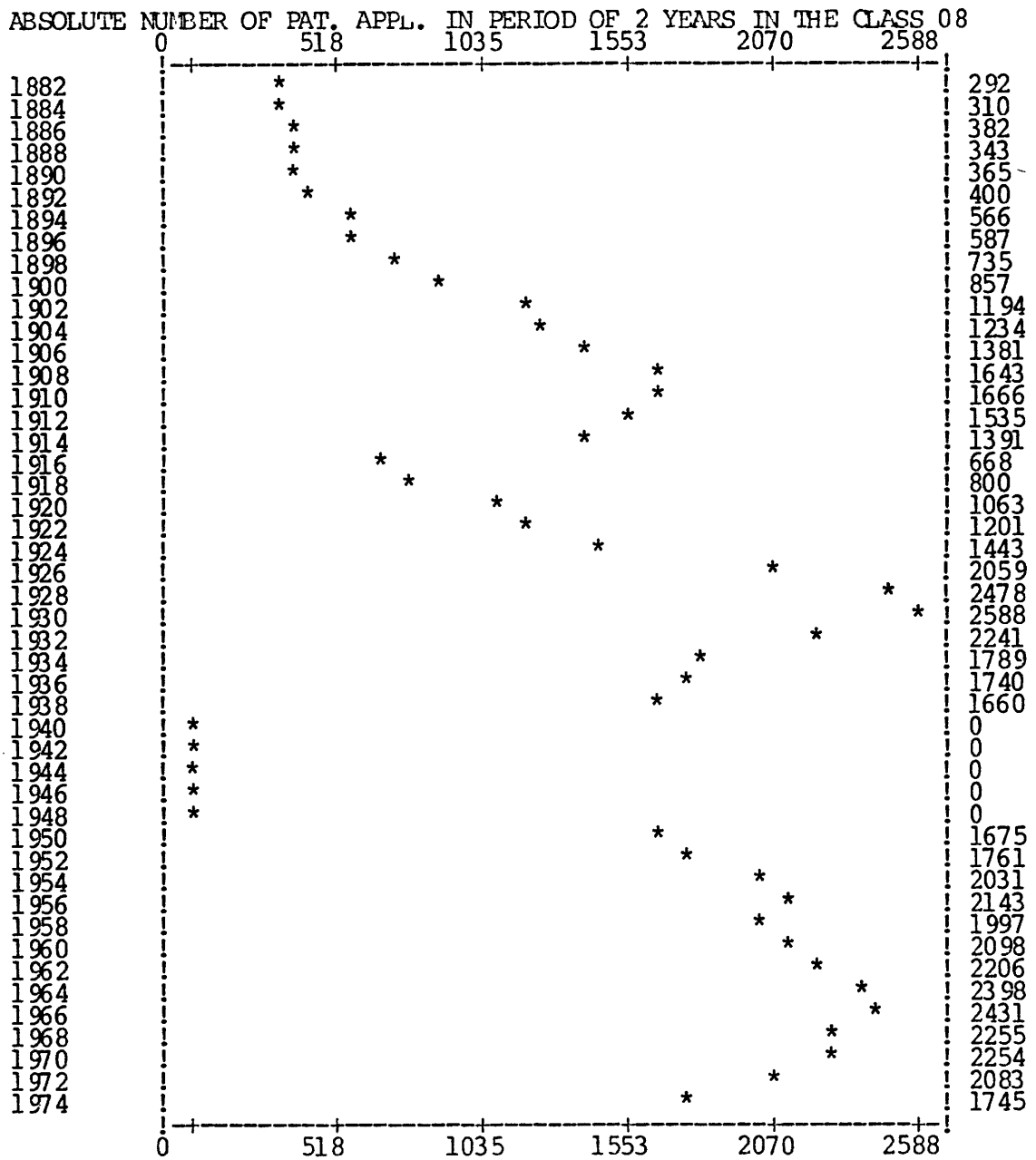

PROPORTION OF TOTAL PAT. APPL. IN 1/1000 IN THE CLASS 08

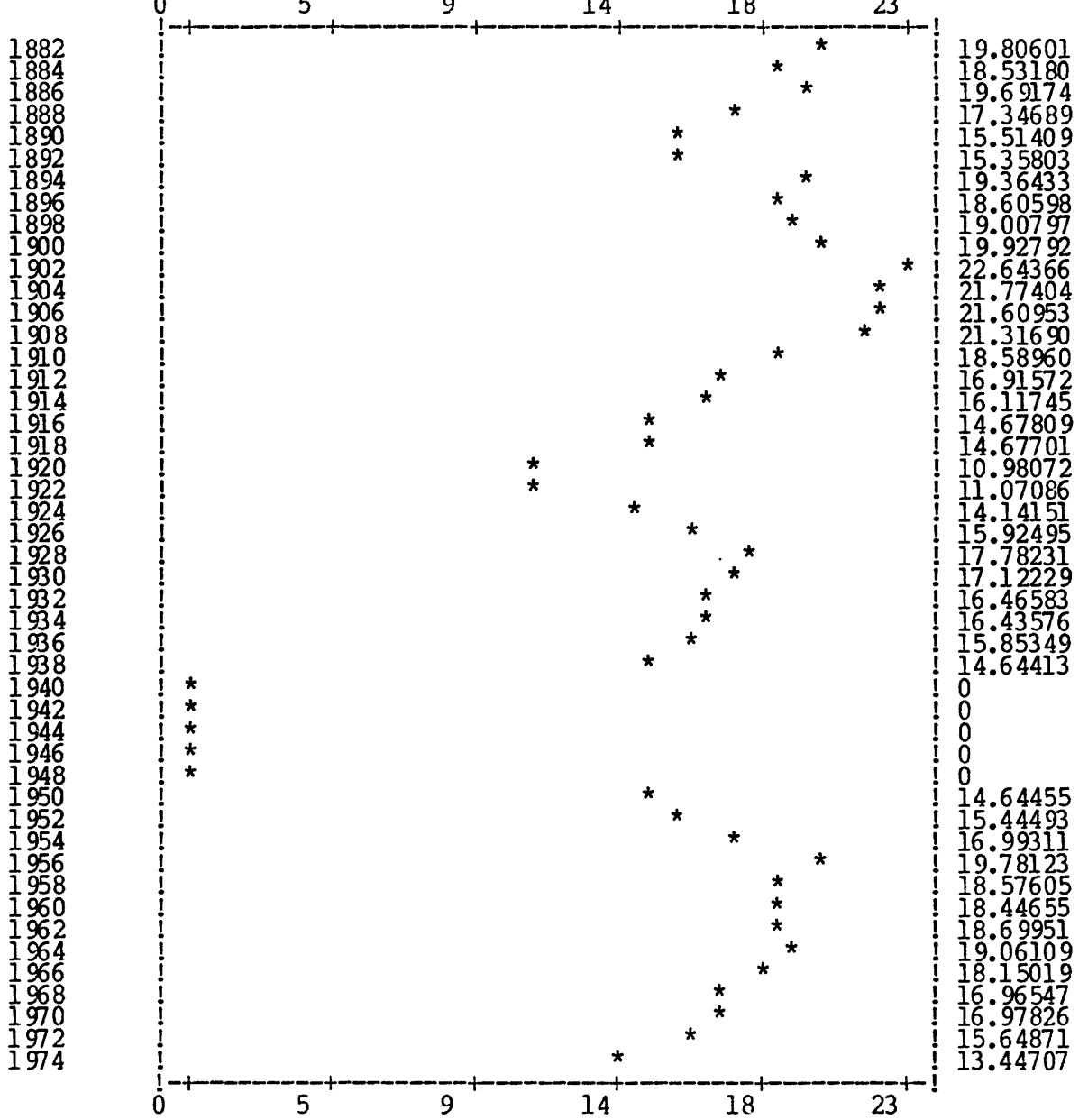



Cl. 9 Brushwear

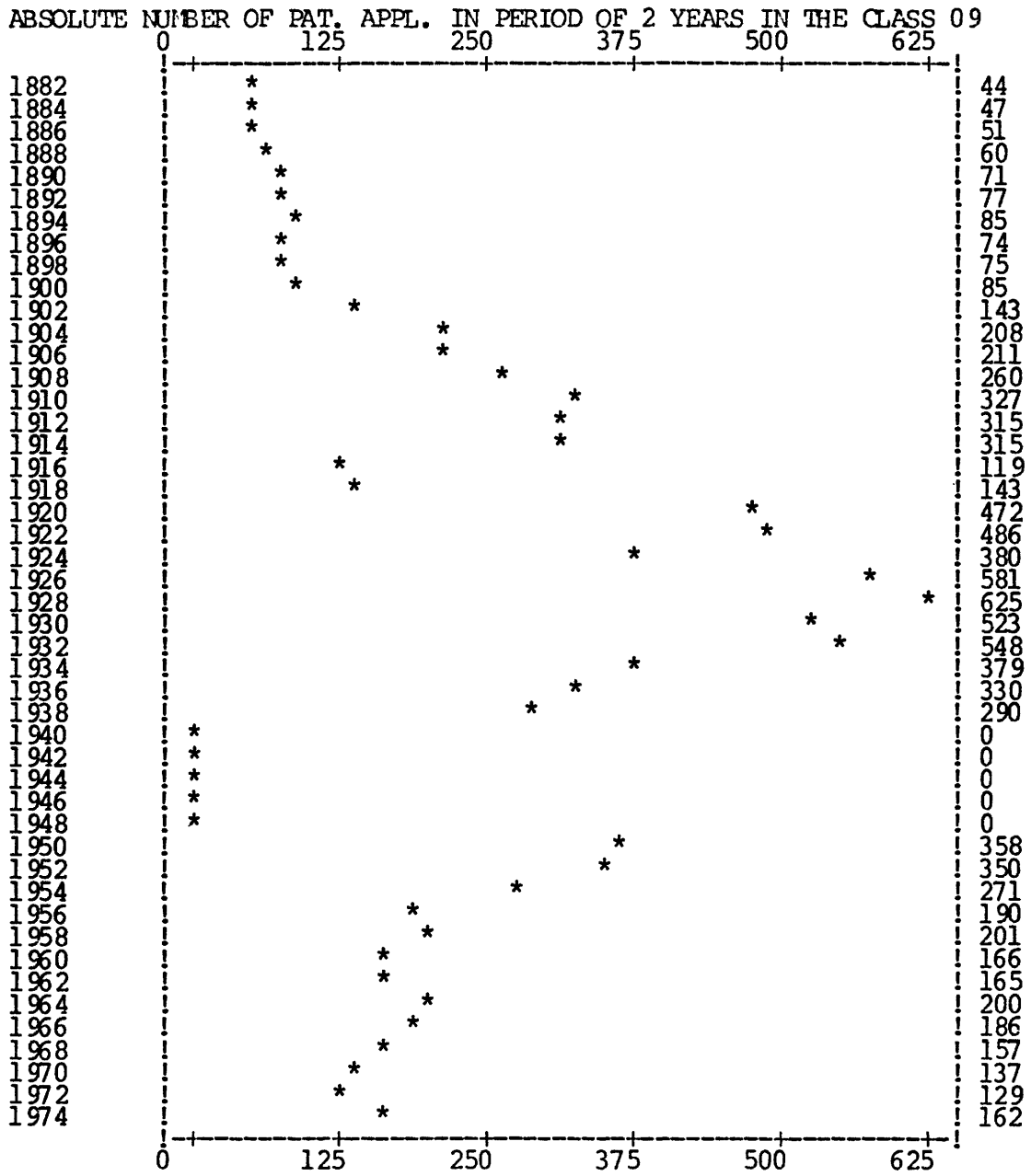

PROPORTION OF TOTAL PAT. APPL. IN 1/1000 IN THE CLASS 09

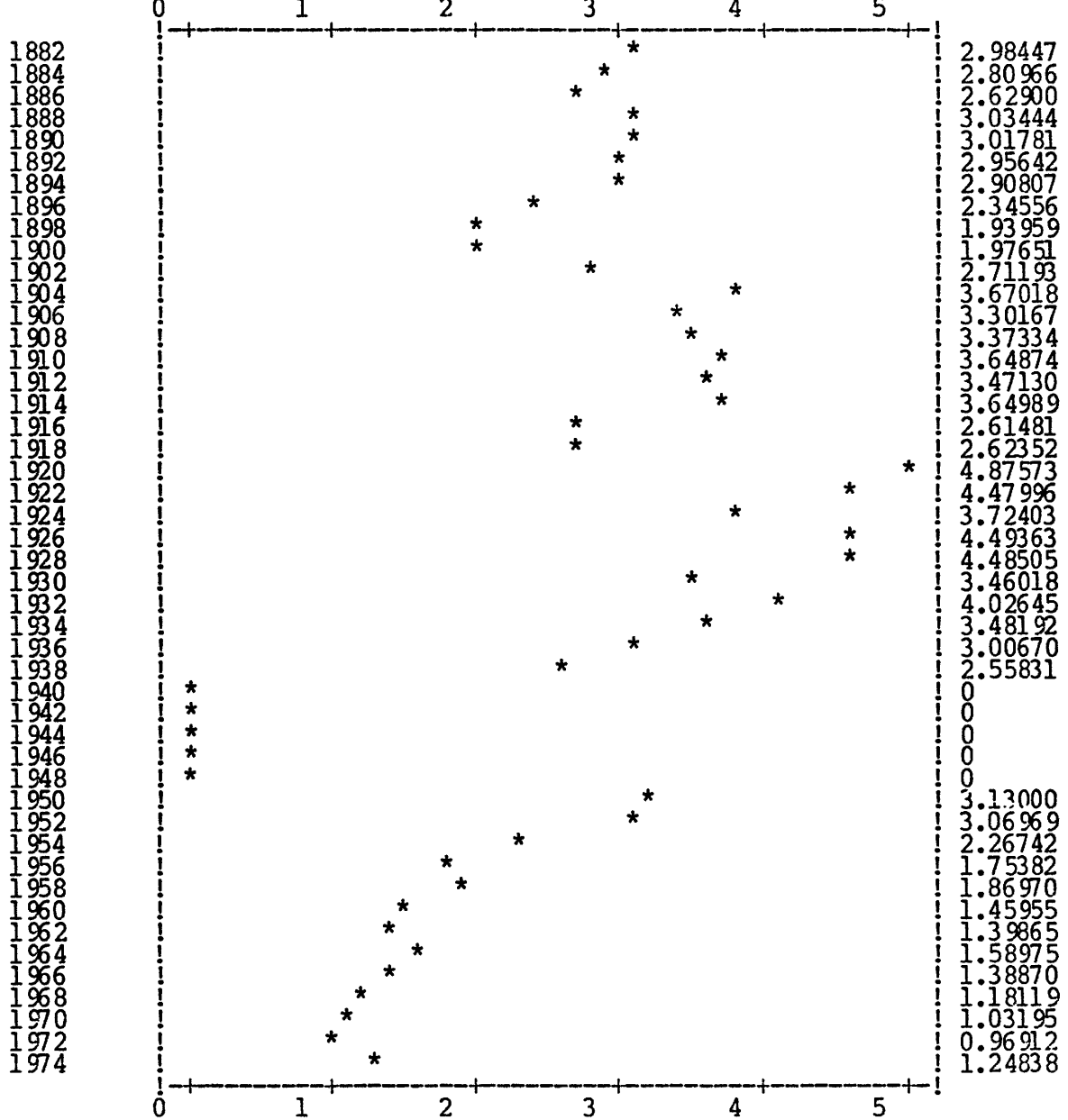

Cl. 10 Fuels

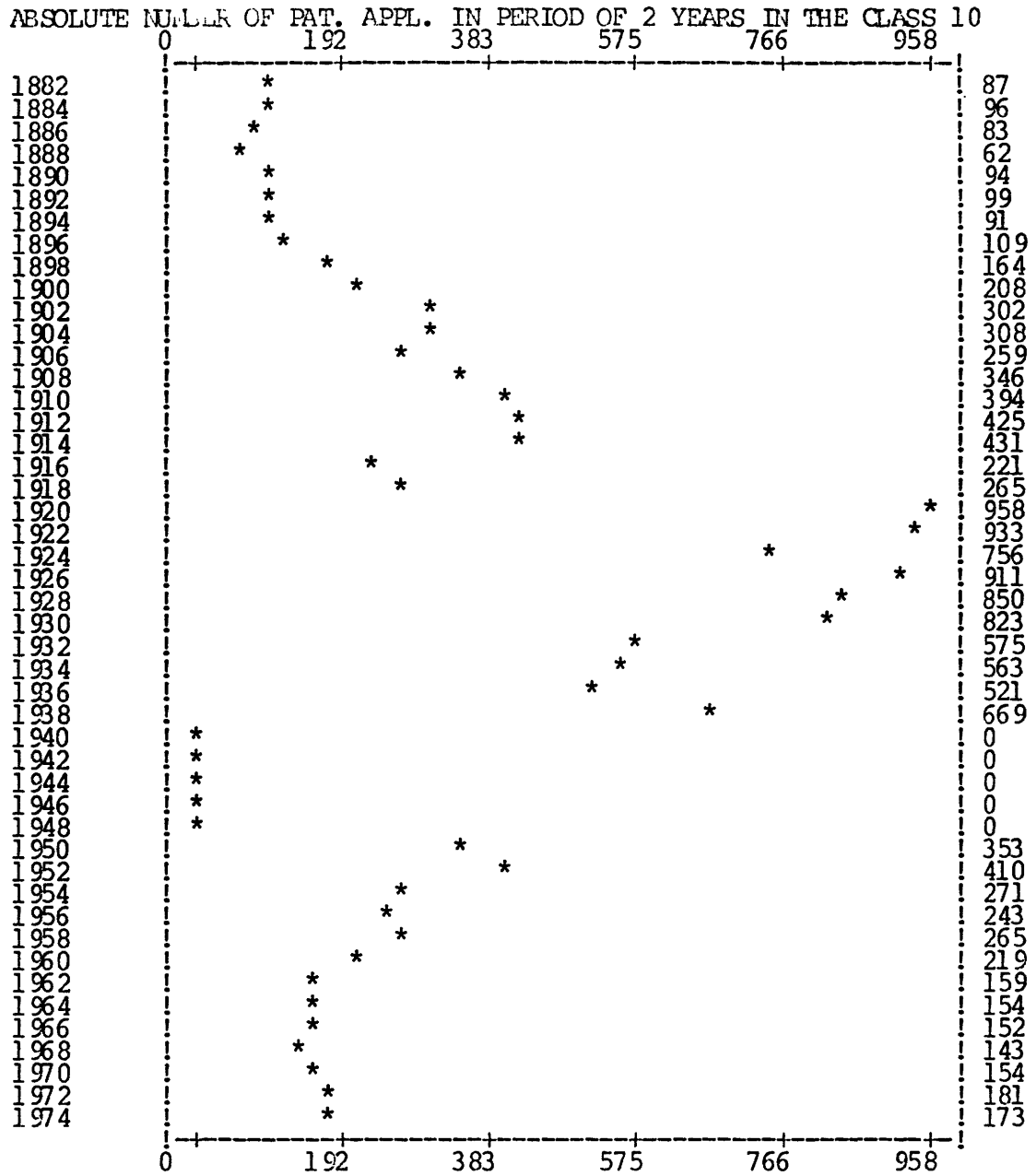

JEAN MEISTER IN KALK BEI KÖLN A. RH.

Hahn mit Schlauchverbindung.

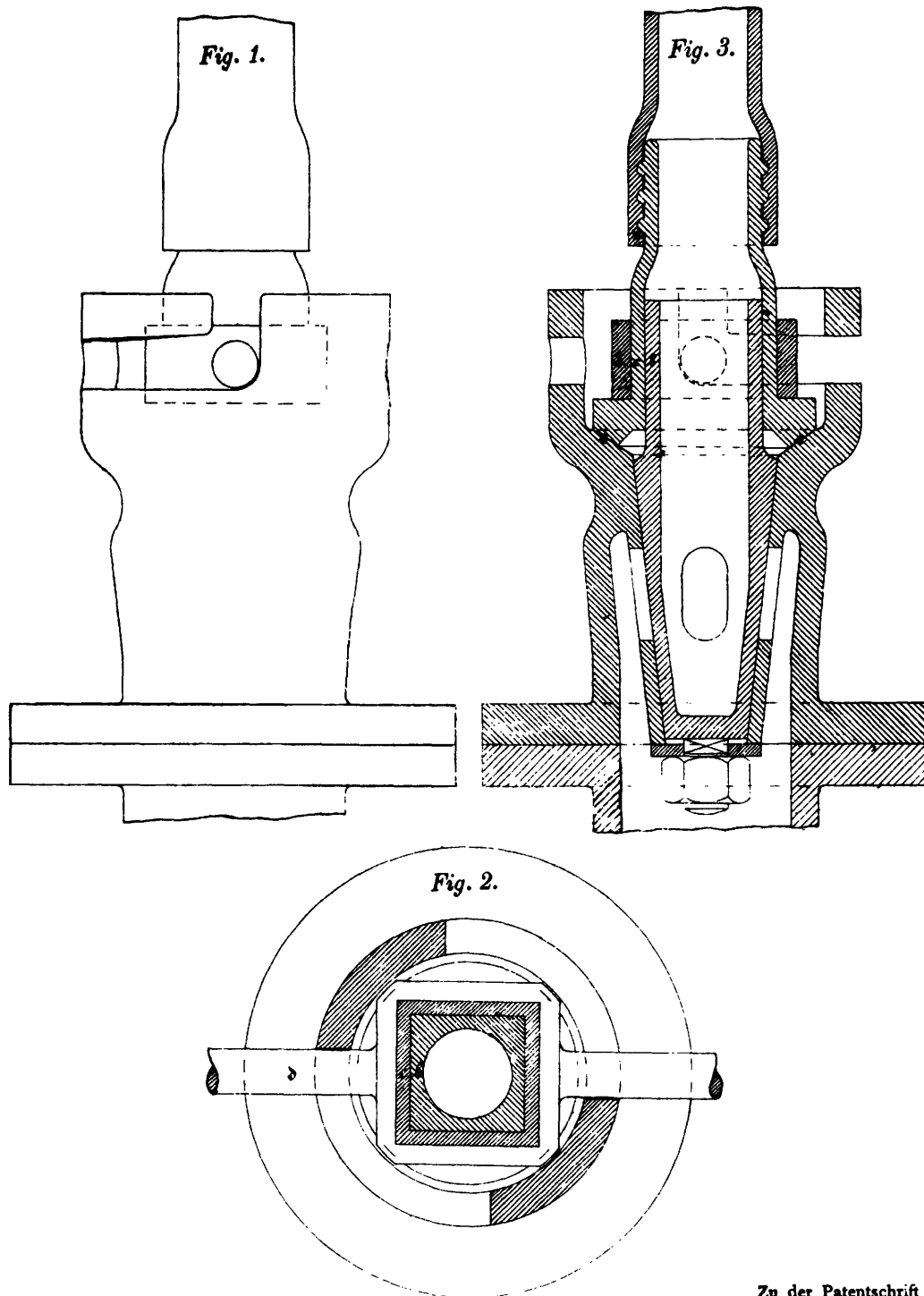

Zu der Patentschrift

№ 115.

PHOTOGR. DRUCK DER KÖNIGL. PREUSS. STAATSDRUCKEREI.

**J. SCHÖN UND M. SCHÖN IN MALSTATT.**  
**Vorrichtung zur Herstellung gefalzter Ofenrohre.**

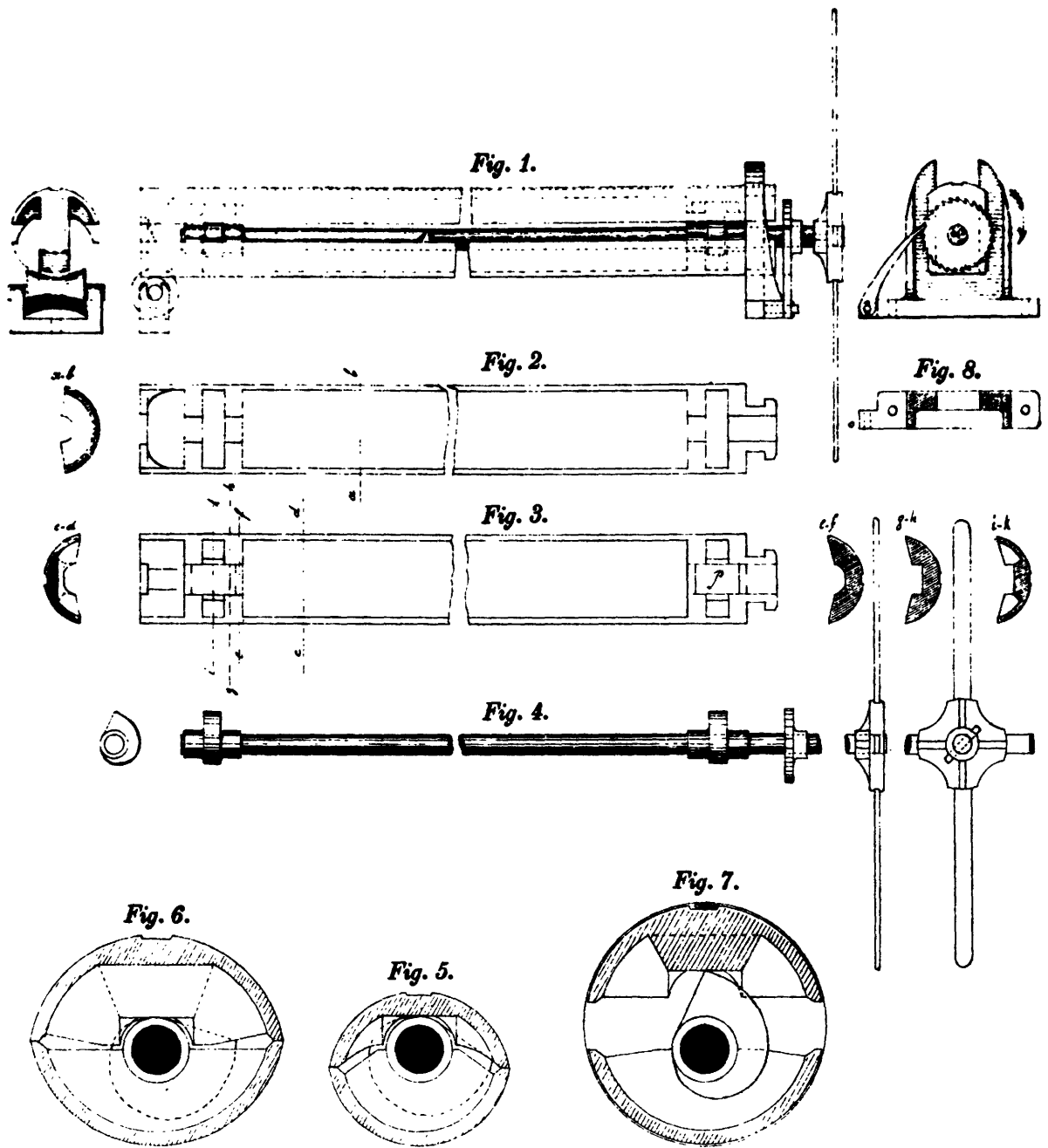

Zu der Patentschrift

**N<sup>o</sup> 107.**

PHOTOGR. DRUCK DER KONIGL. PREUSS. STAATSDRUCKEREI.

PROPORTION OF TOTAL PAT. APPL. IN 1/1000 IN THE CLASS 10

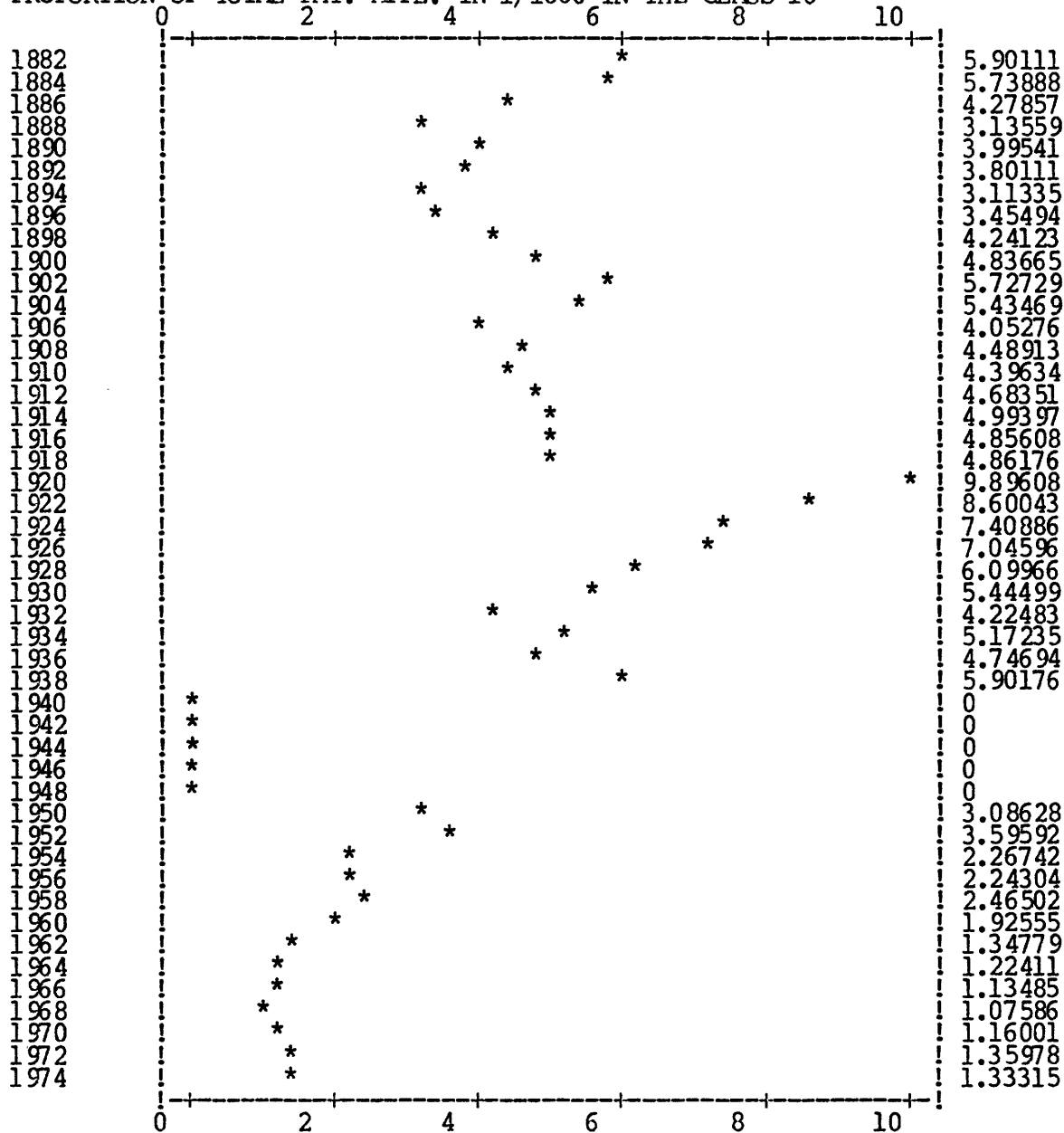

Cl. 11 Bookbinding, albums, files and special printed matter

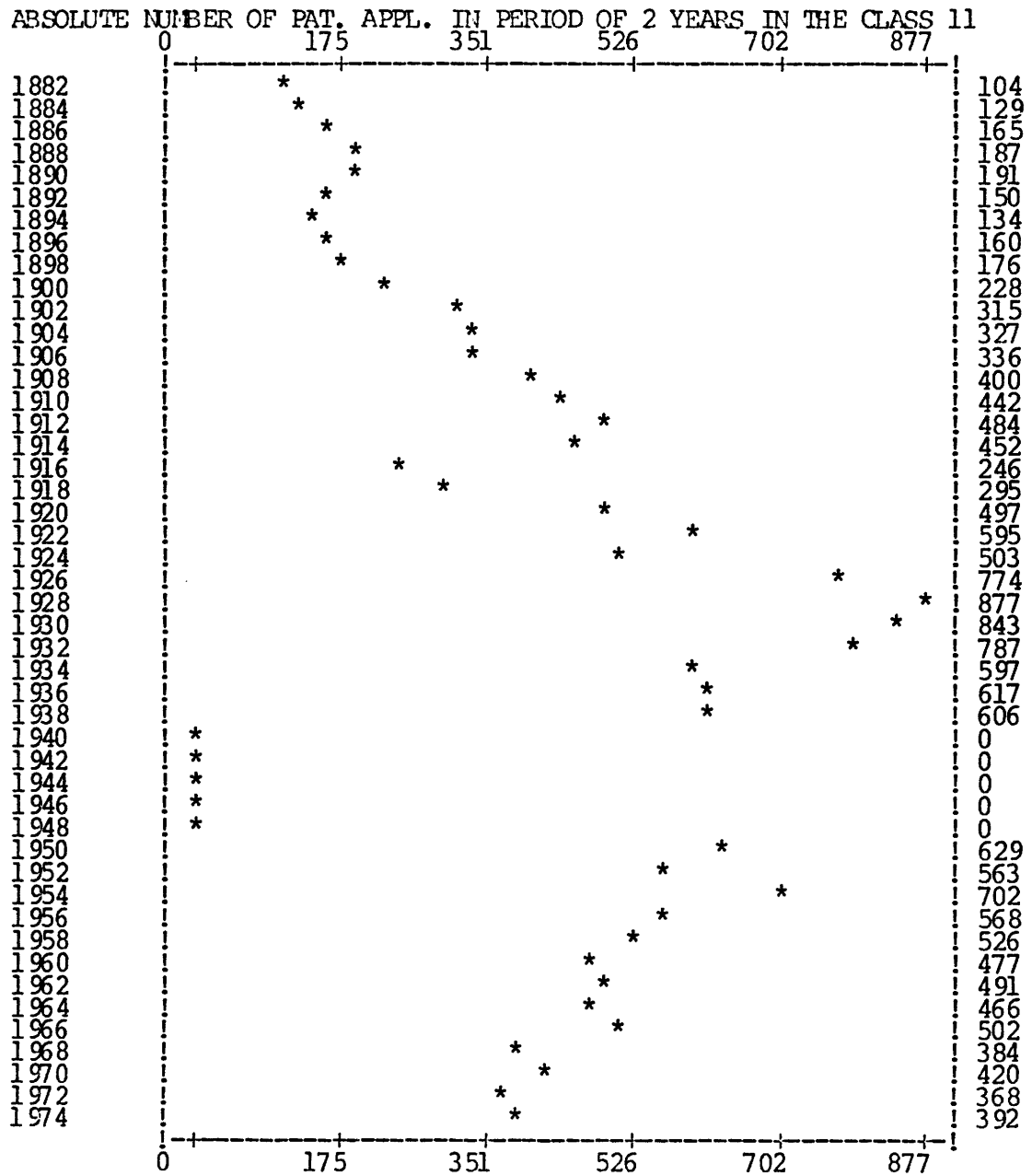

PROPORTION OF TOTAL PAT. APPL. IN 1/1000 IN THE CLASS 11

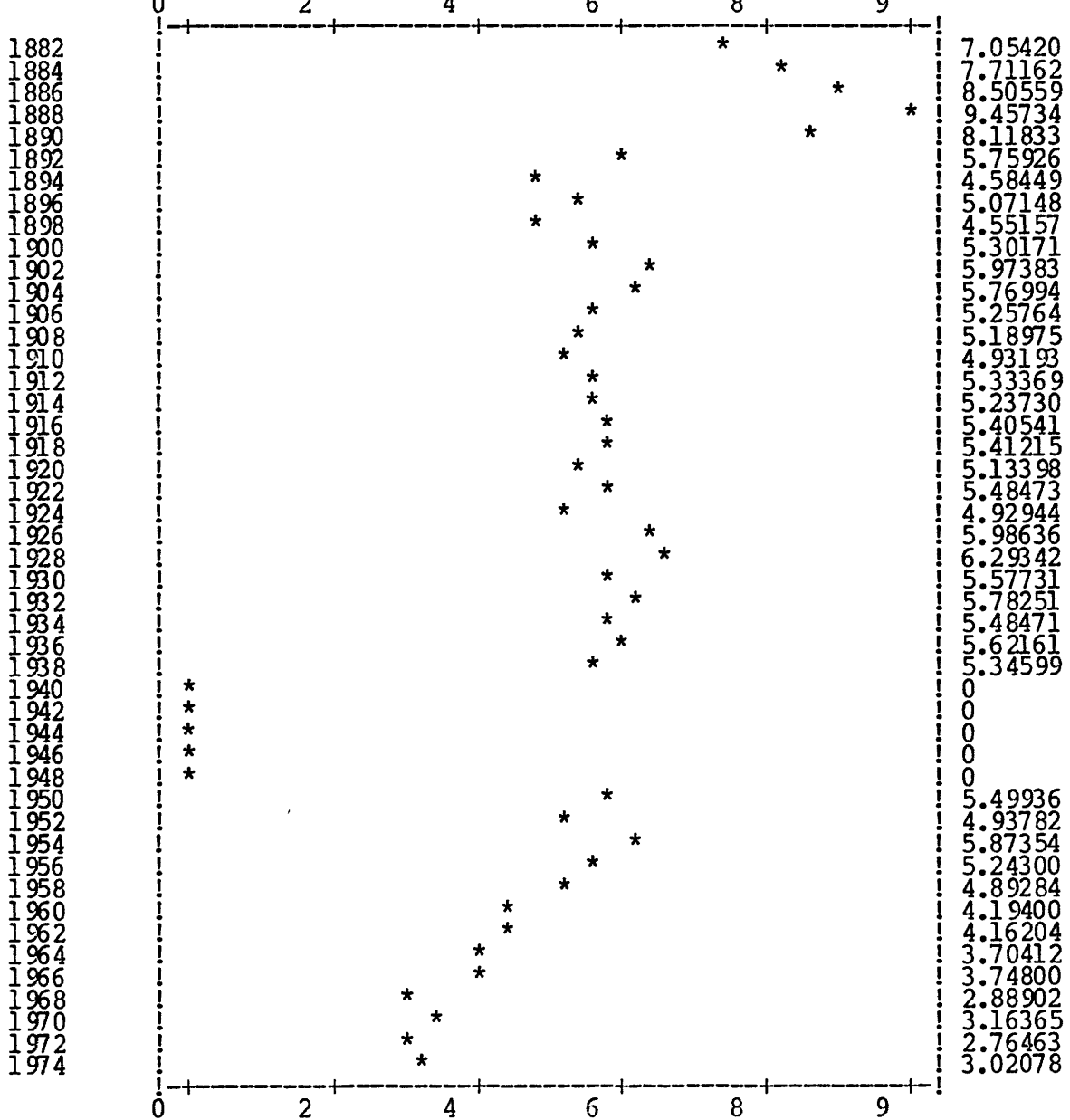



Cl. 12 Chemical processes and apparatus not included in other special classes

ABSOLUTE NUMBER OF PAT. APPL. IN PERIOD OF 2 YEARS IN THE CLASS 12

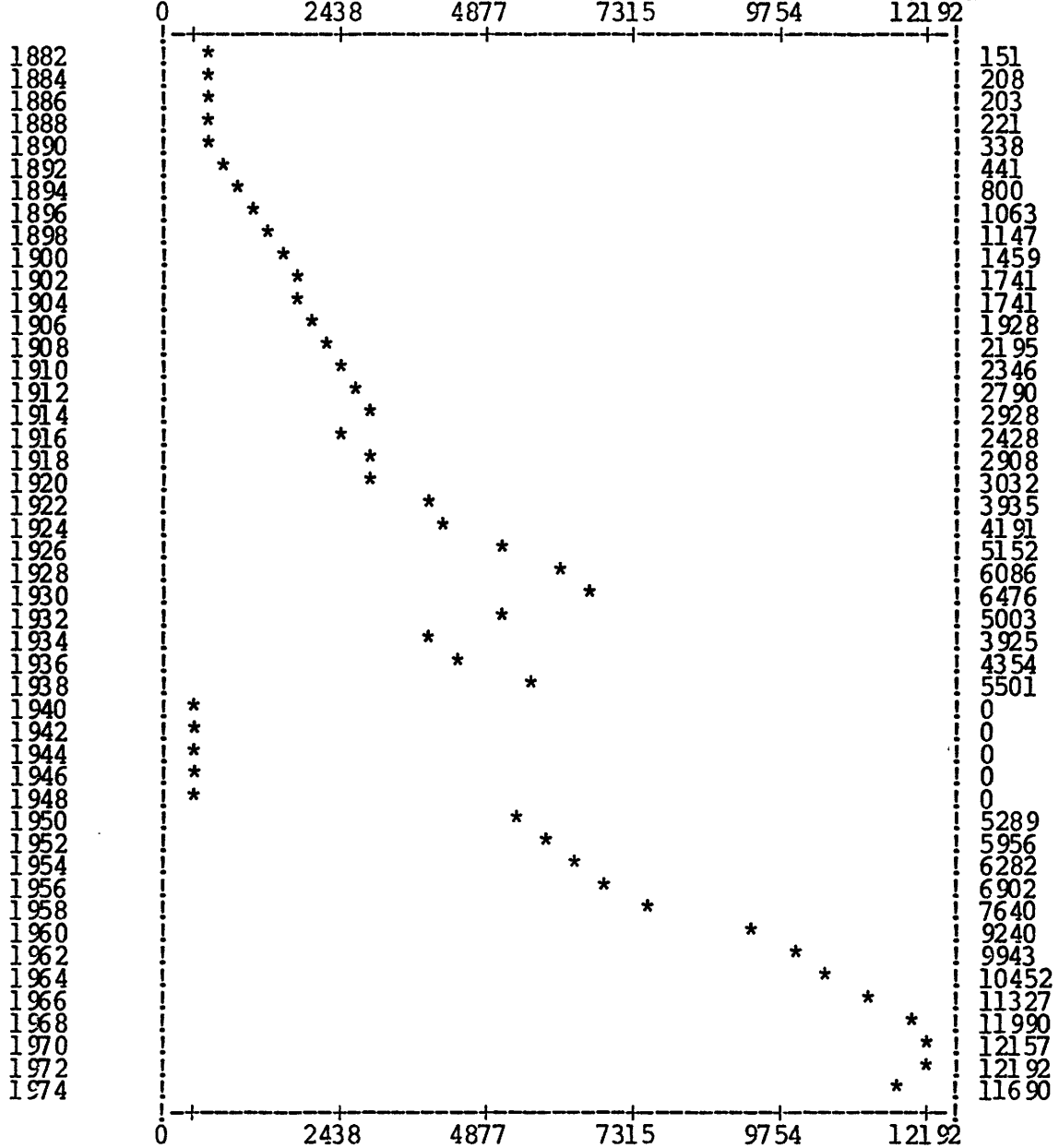

PROPORTION OF TOTAL PAT. APPL. IN 1/1000 IN THE CLASS 12

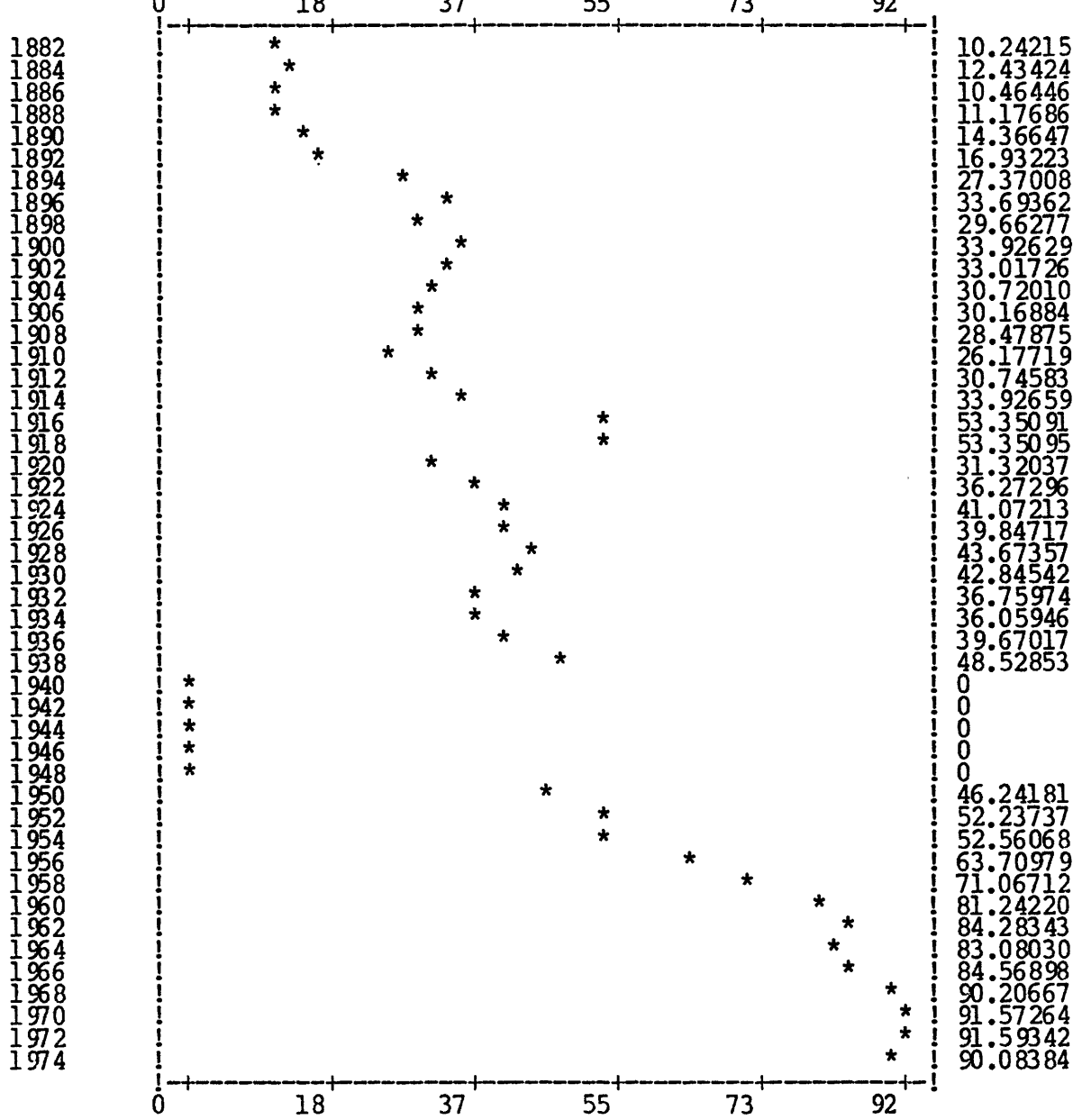

C1.13 Steam boilers for power generation and related equipment, steaming capacity

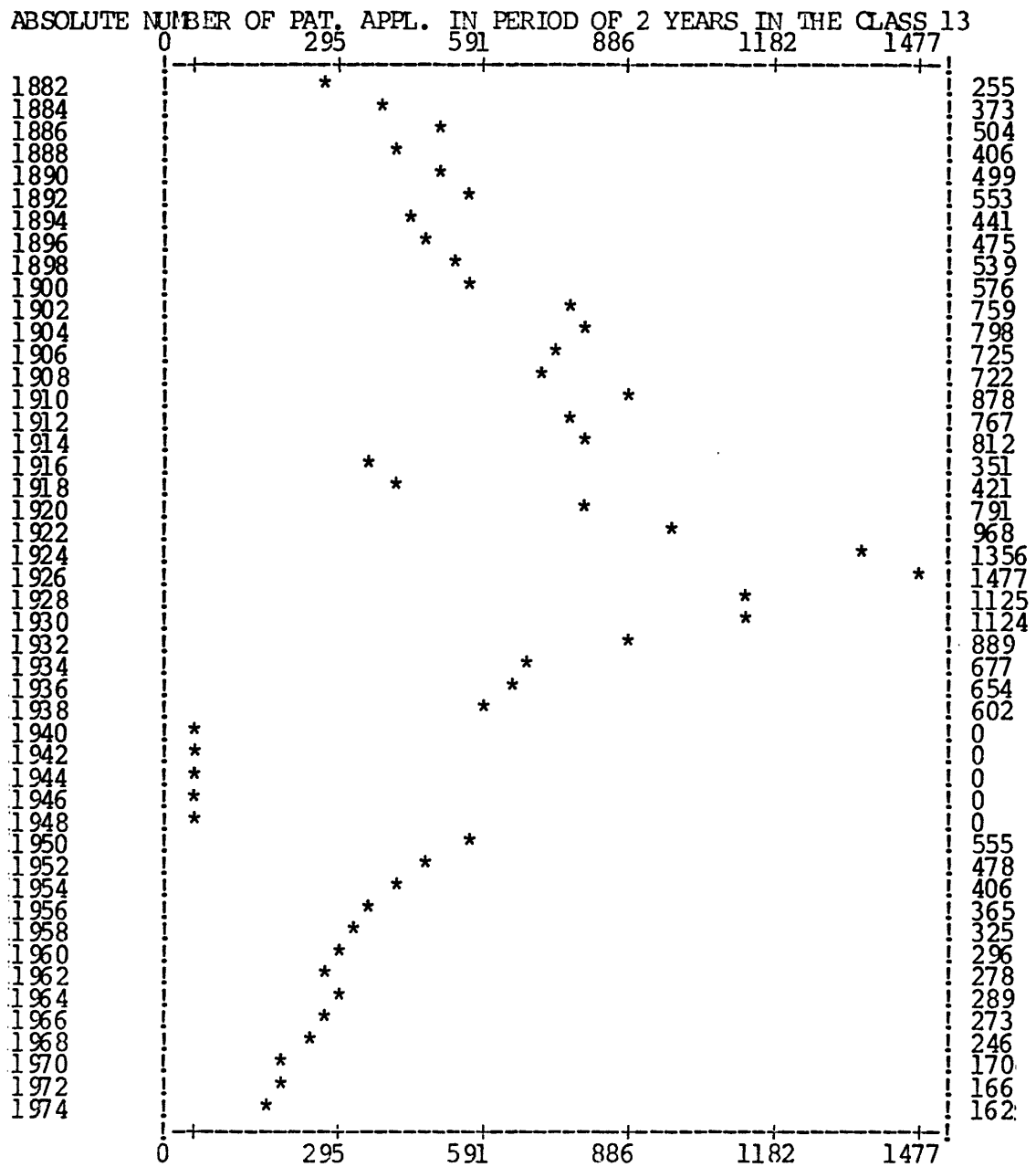

PROPORTION OF TOTAL PAT. APPL. IN 1/1000 IN THE CLASS 13

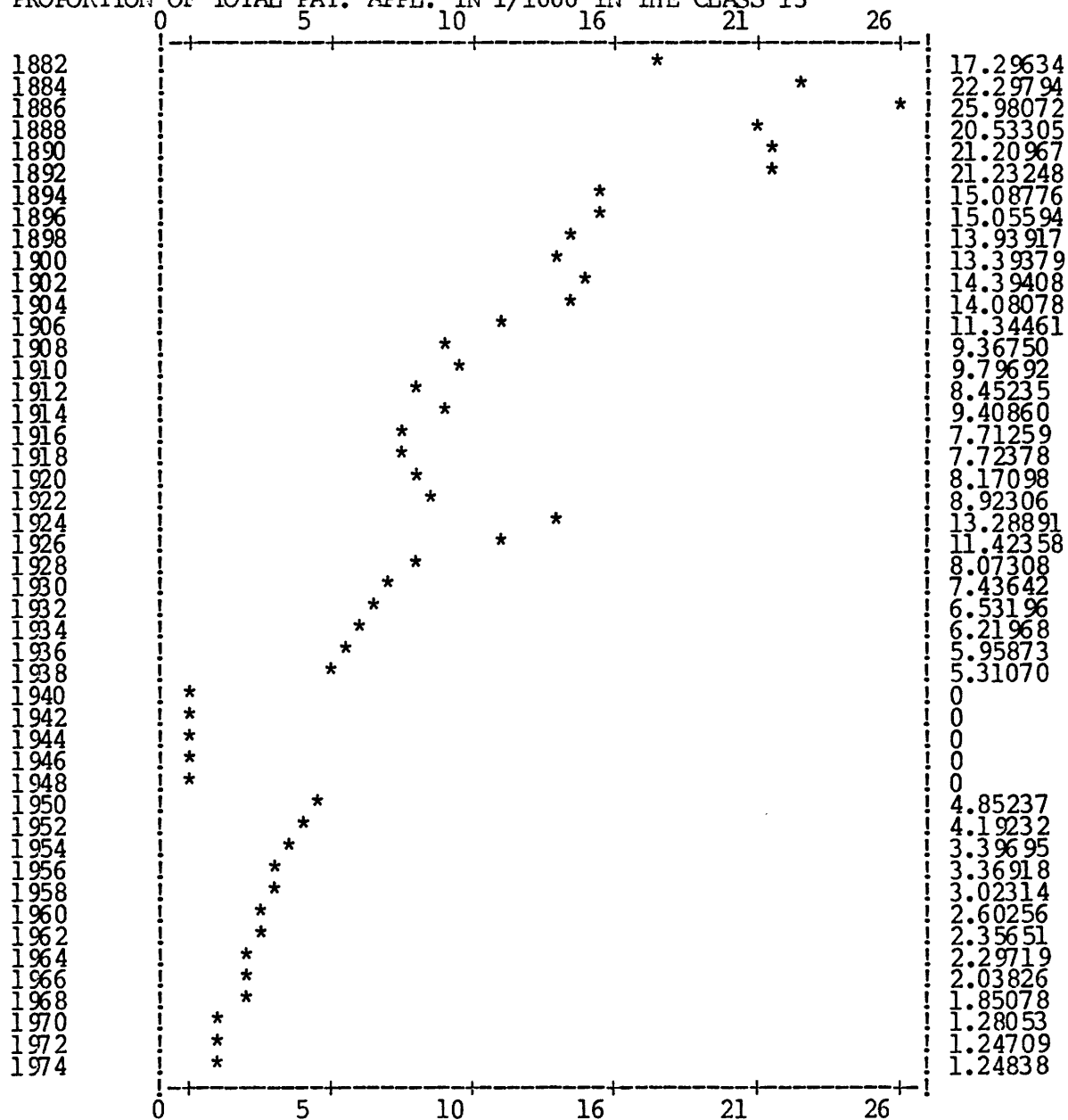

Cl. 14 Machines or engines in general, steam engines, power generating plant in general; periodic control, lubrication, exhaust devices or silencers for gases, cooling of machines or engines, particularly combustion engines

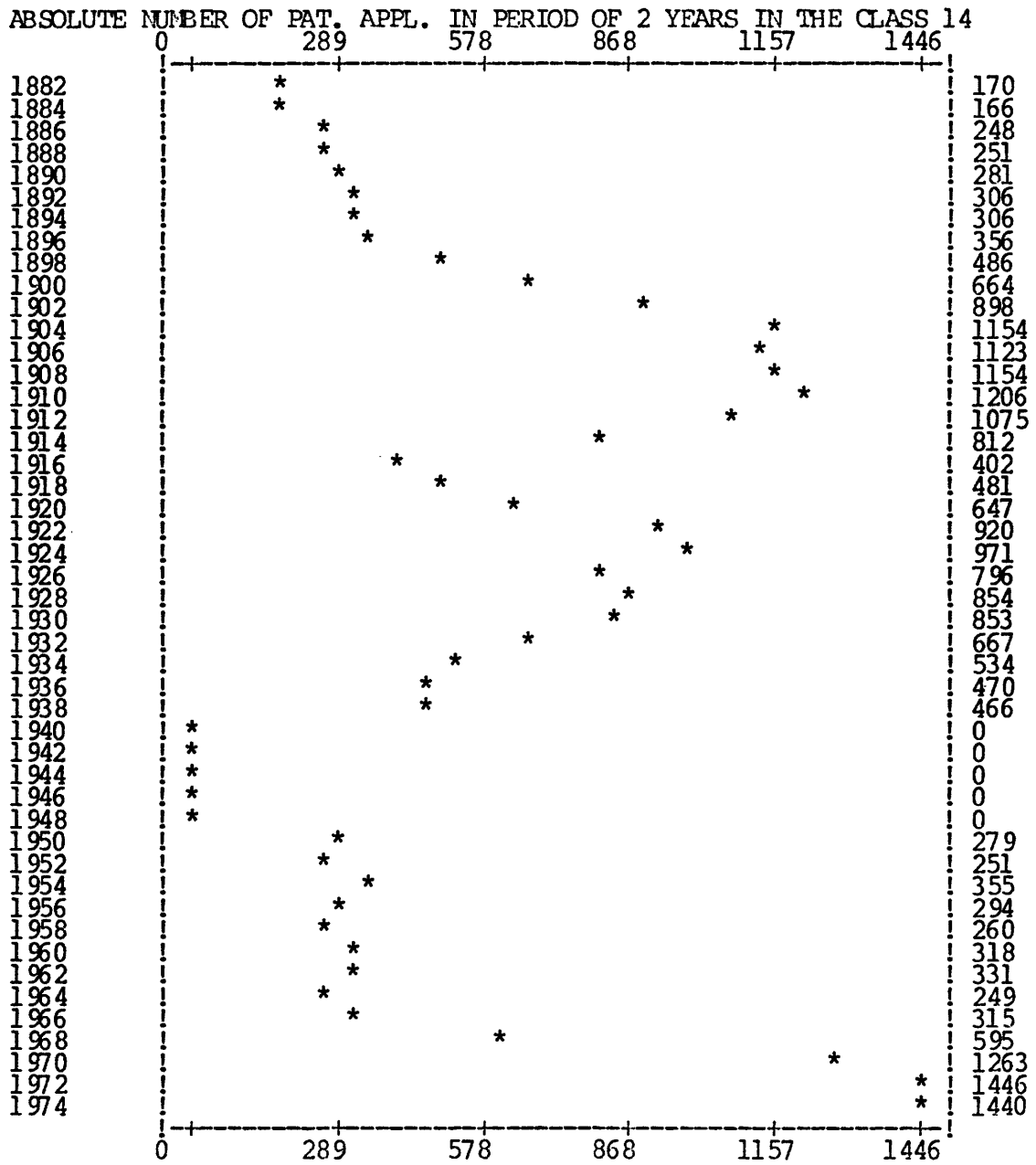

PROPORTION OF TOTAL PAT. APPL. IN 1/1000 IN THE CLASS 14

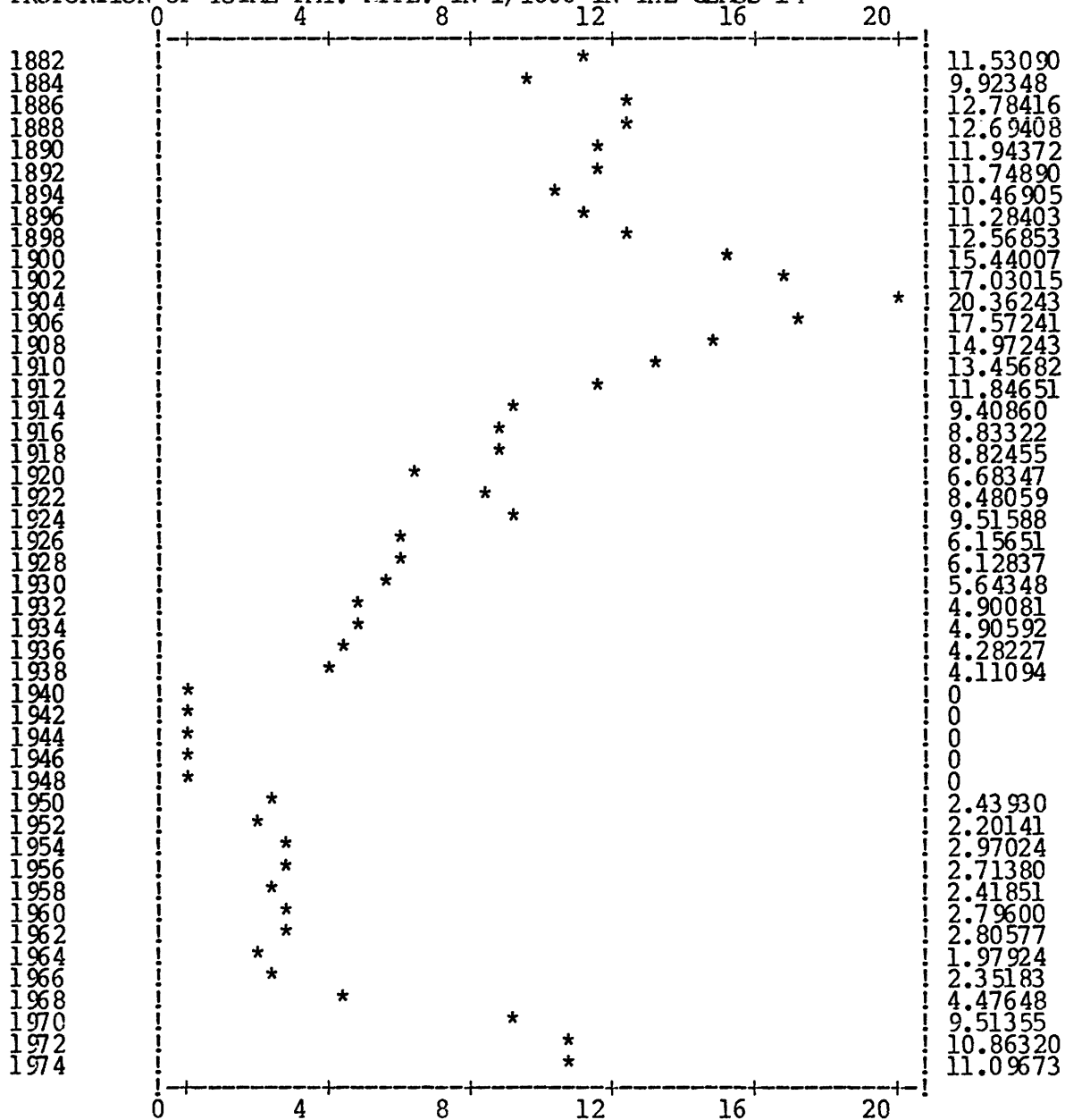

C1. 15 Printing, lining machines, typewriters, stamps

ABSOLUTE NUMBER OF PAT. APPL. IN PERIOD OF 2 YEARS IN THE CLASS 15

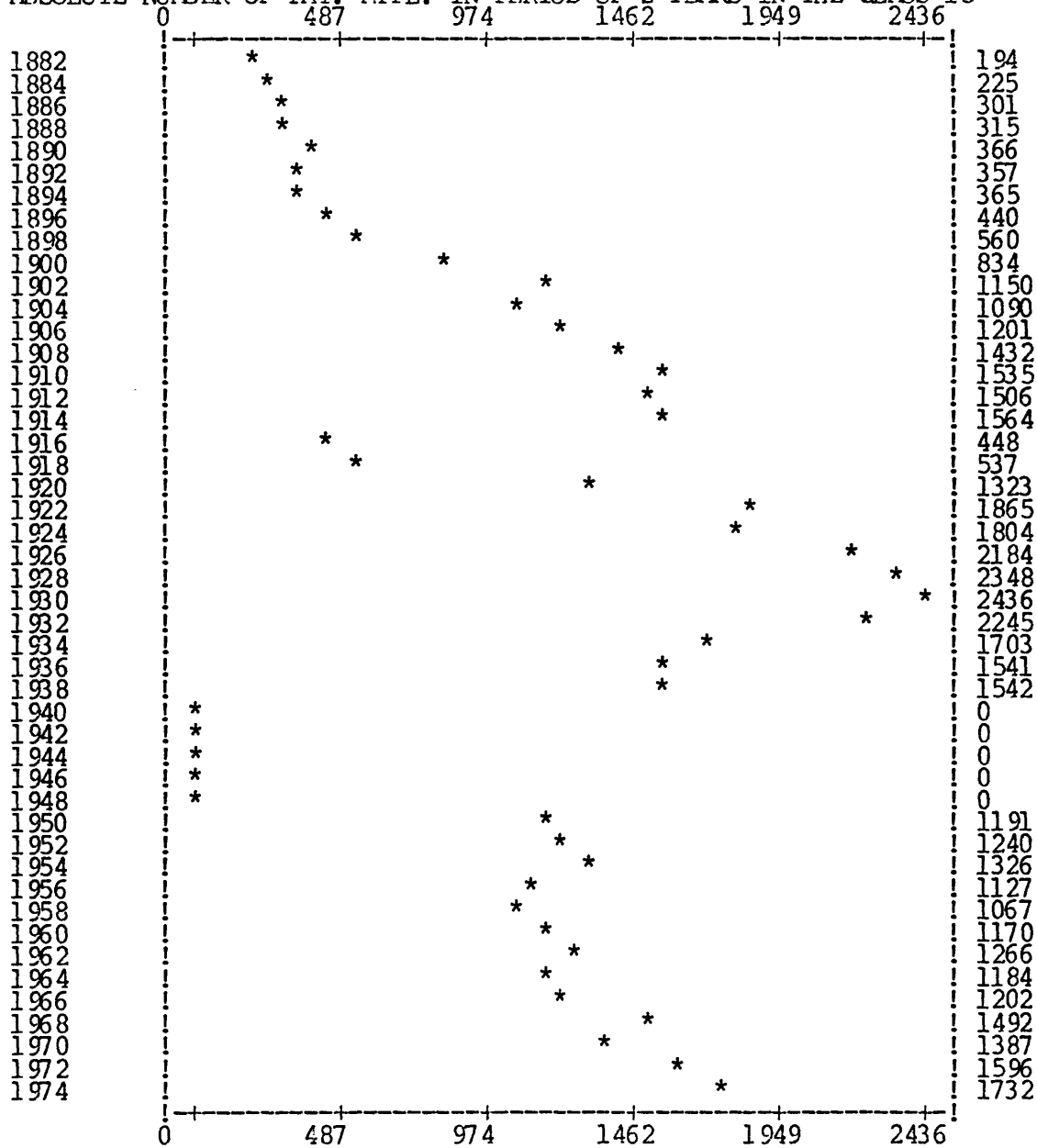

PROPORTION OF TOTAL PAT. APPL. IN 1/1000 IN THE CLASS 15

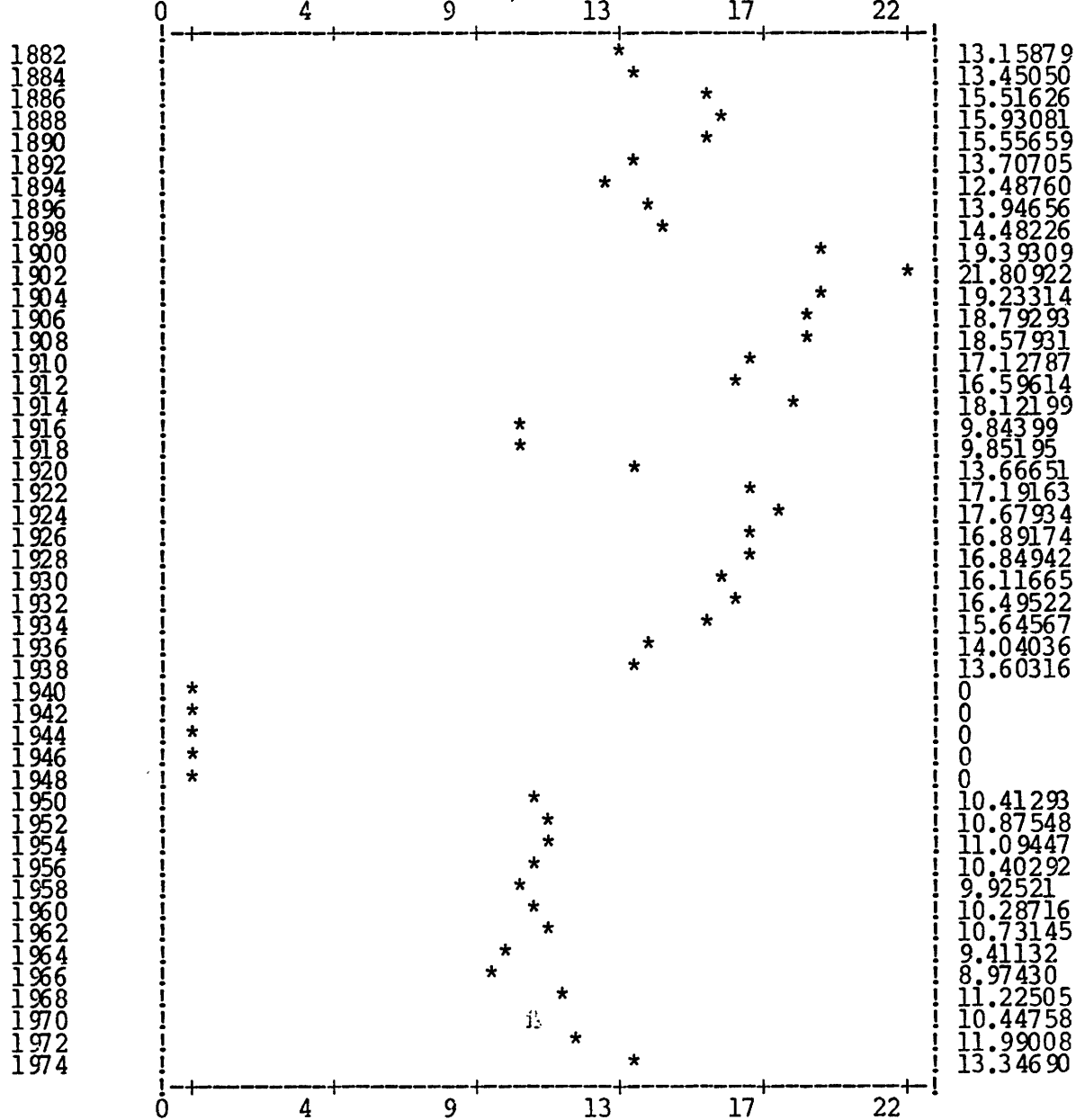



Cl. 16 Manufacture of fertilizers

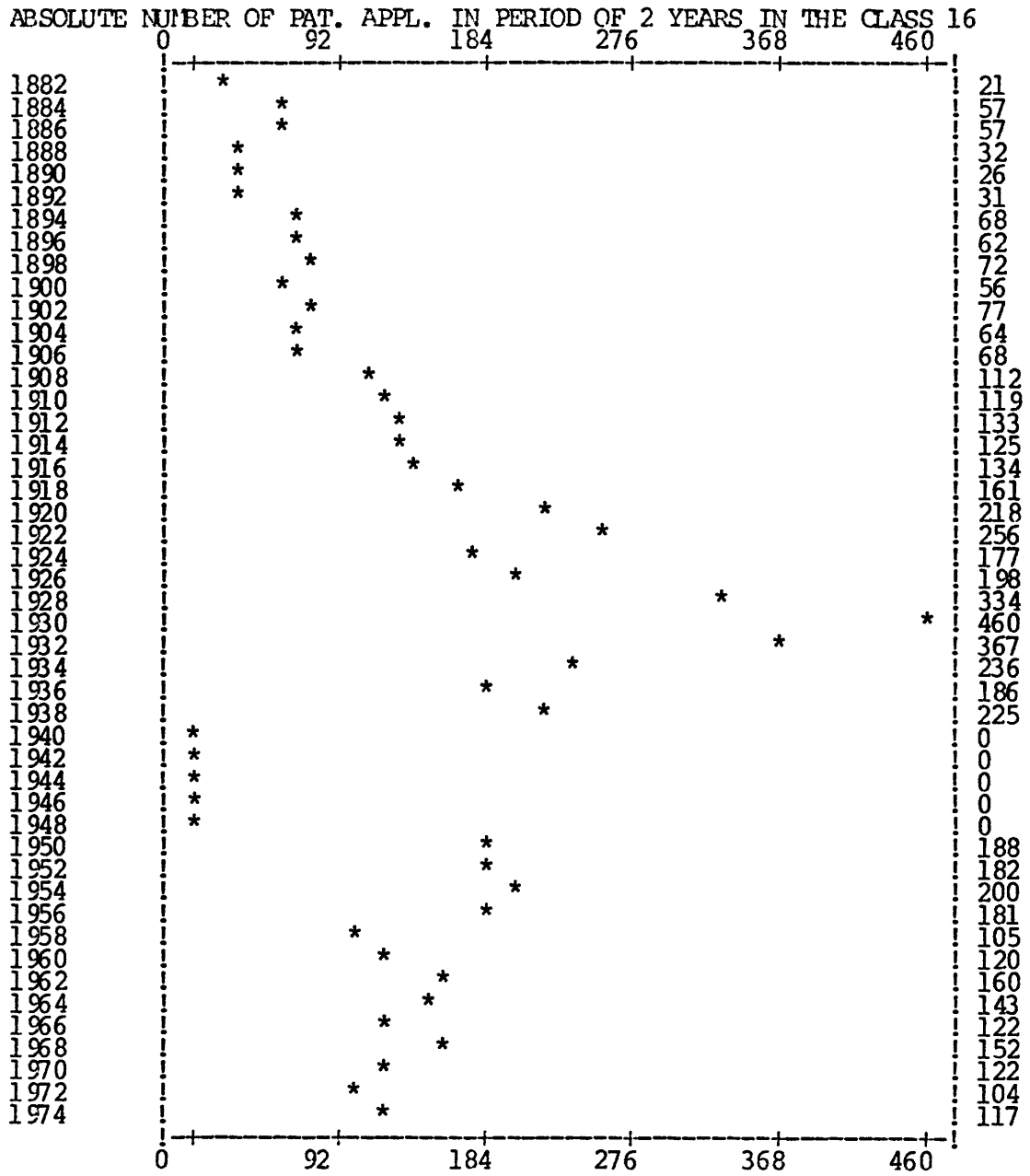

PROPORTION OF TOTAL PAT. APPL. IN 1/1000 IN THE CLASS 16

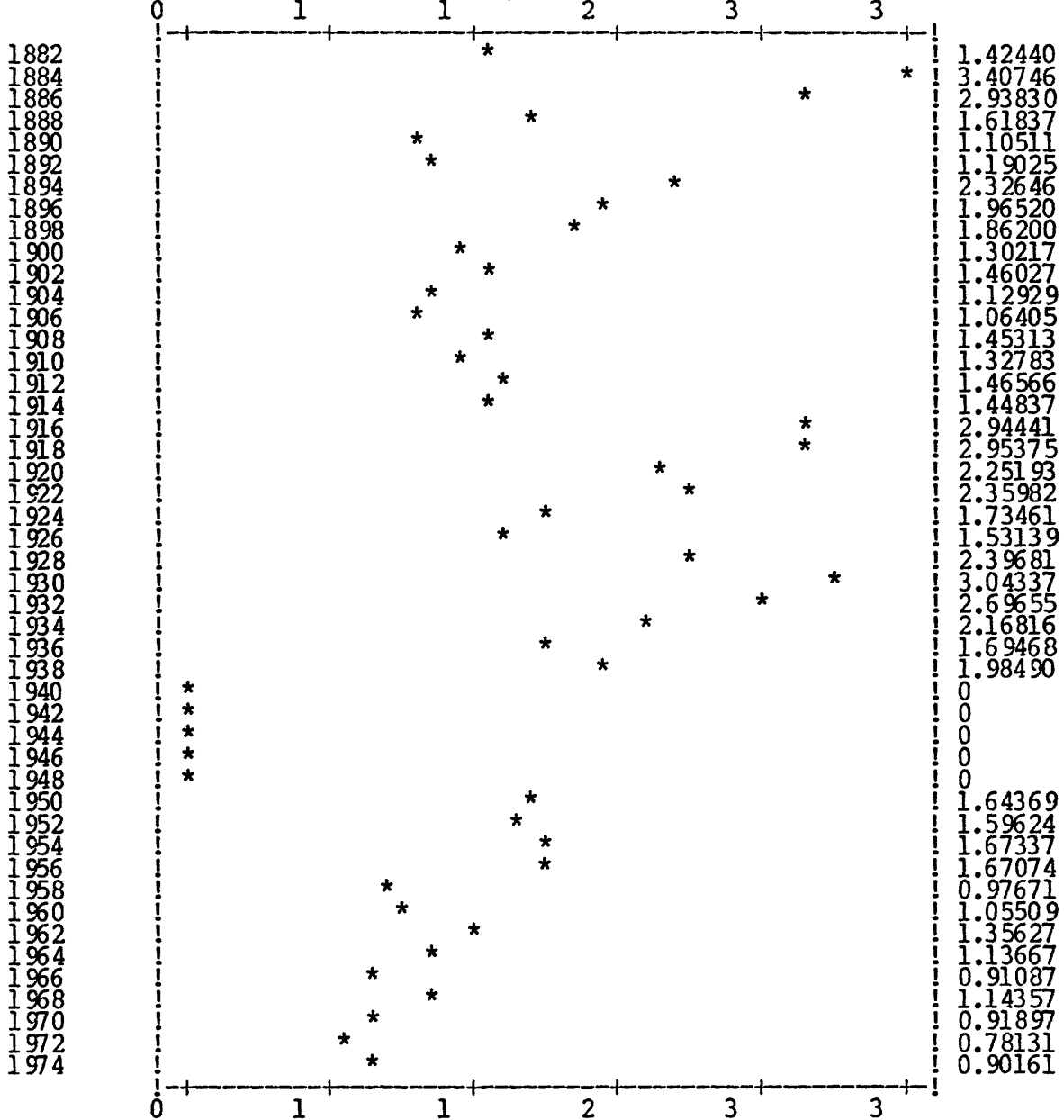

Cl. 17 Refrigeration or cooling, storage of ice, heat transfer, liquefaction by mechanical means of gases or gas mixtures, e.g. air, which do not condense easily

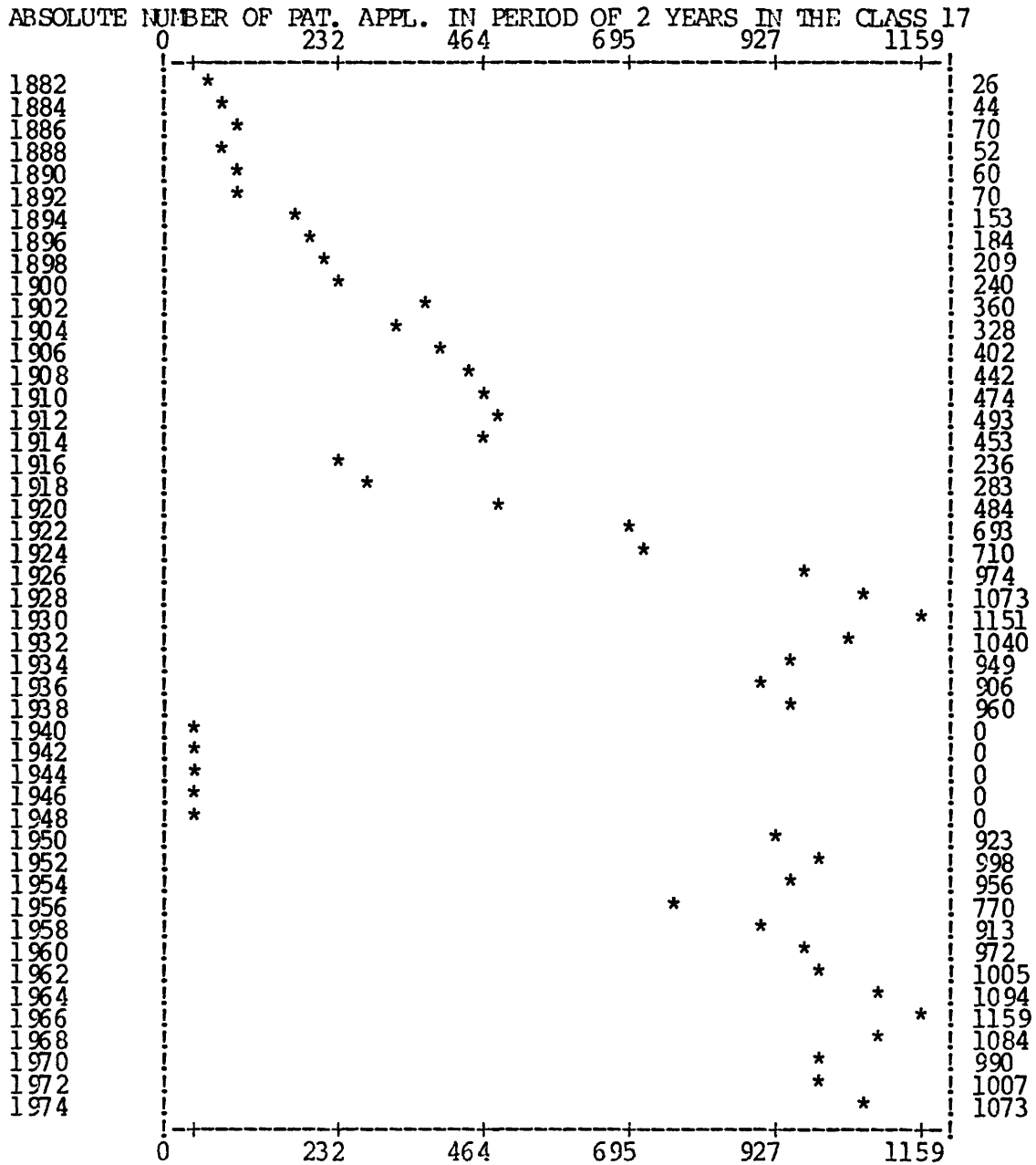

PROPORTION OF TOTAL PAT. APPL. IN 1/1000 IN THE CLASS 17

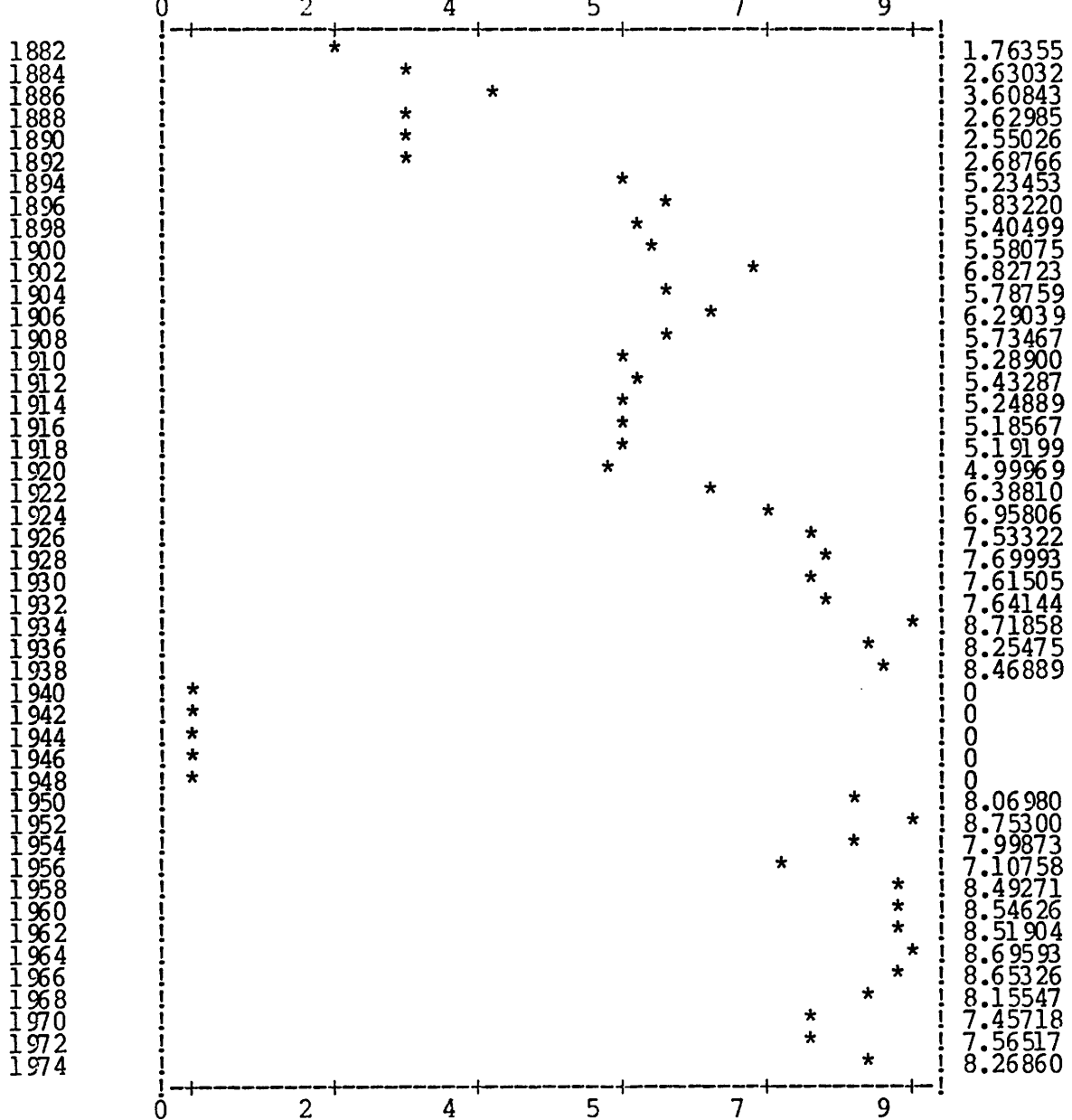

Cl. 18 Metallurgy of iron

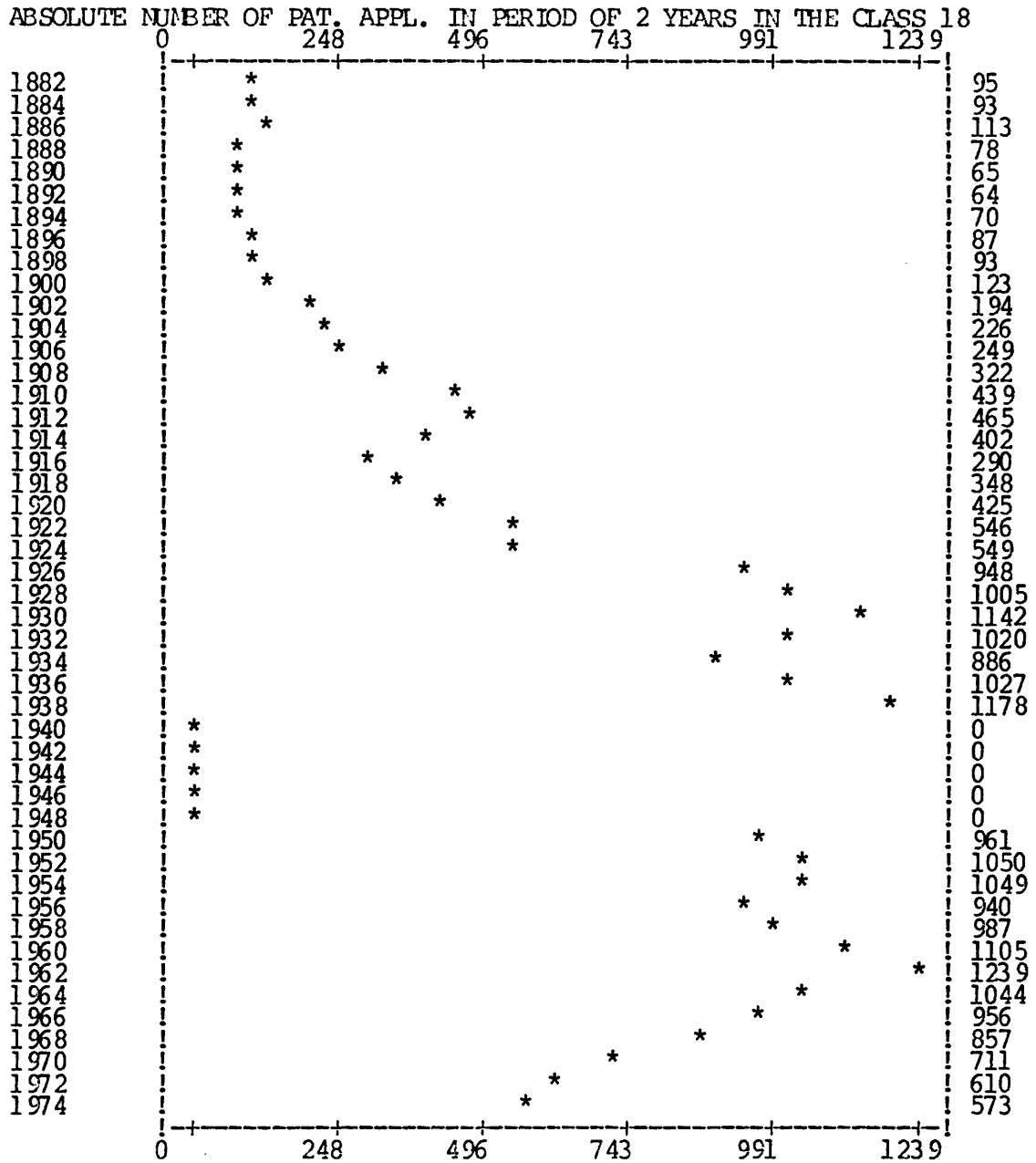

PROPORTION OF TOTAL PAT. APPL. IN 1/1000 IN THE CLASS 18

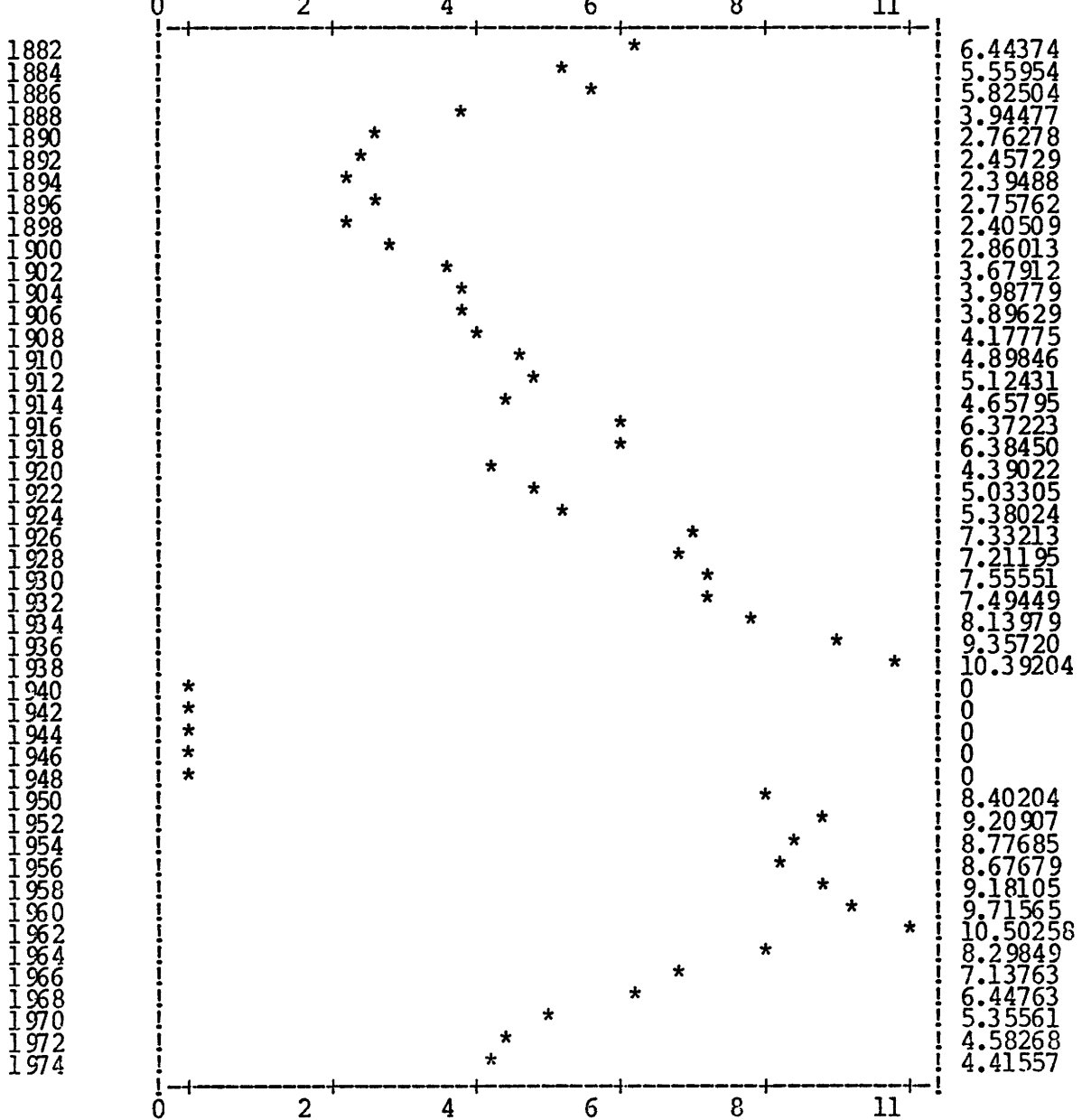

Cl. 19 Construction of roads, railways and bridges

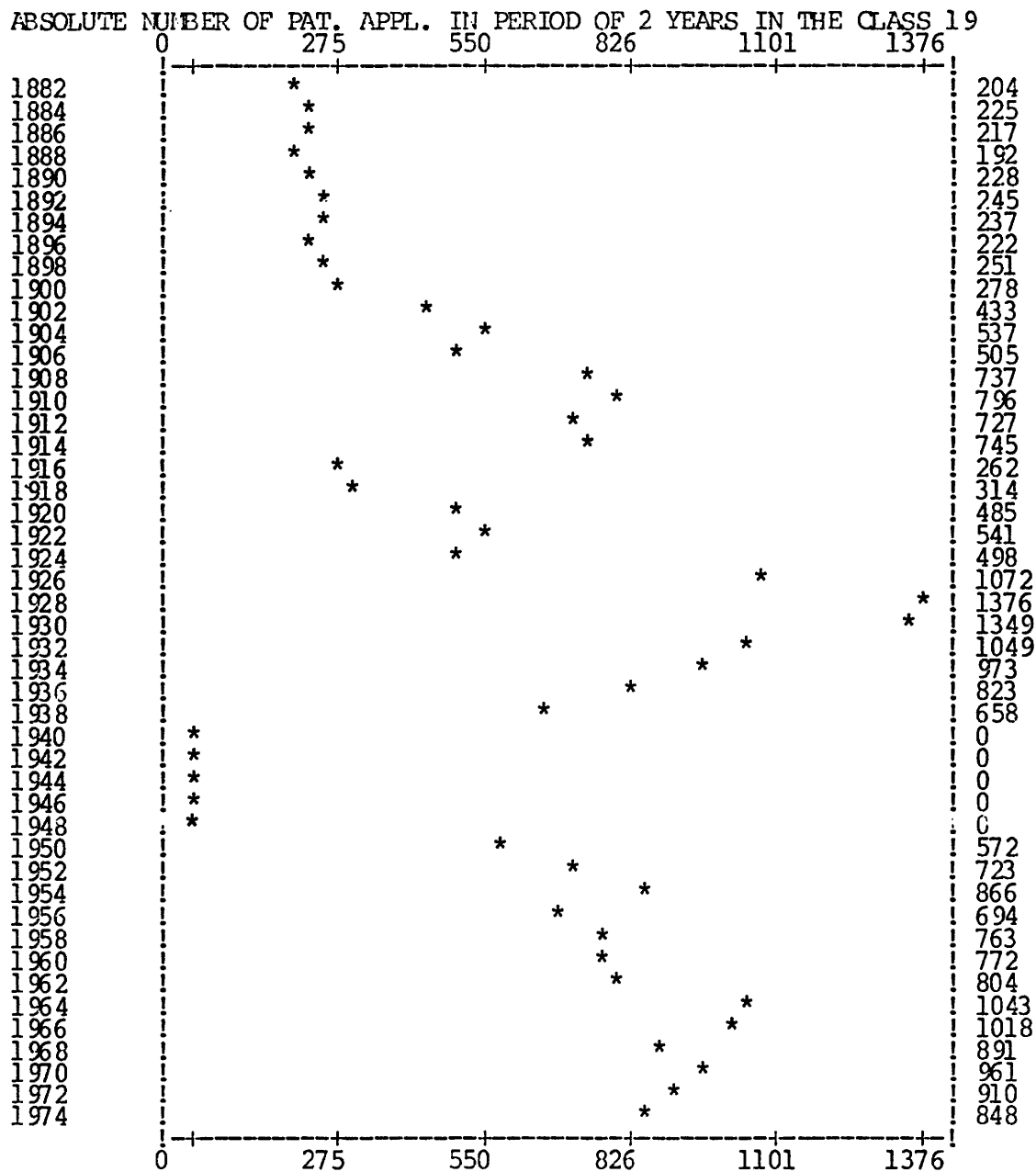

H. BAECKER IN REMSCHEID.

Schneckenvorgelege an Spindelschraubstücken aller Art zum Zweck eines leichten und sicheren Aus- und Einspannens.

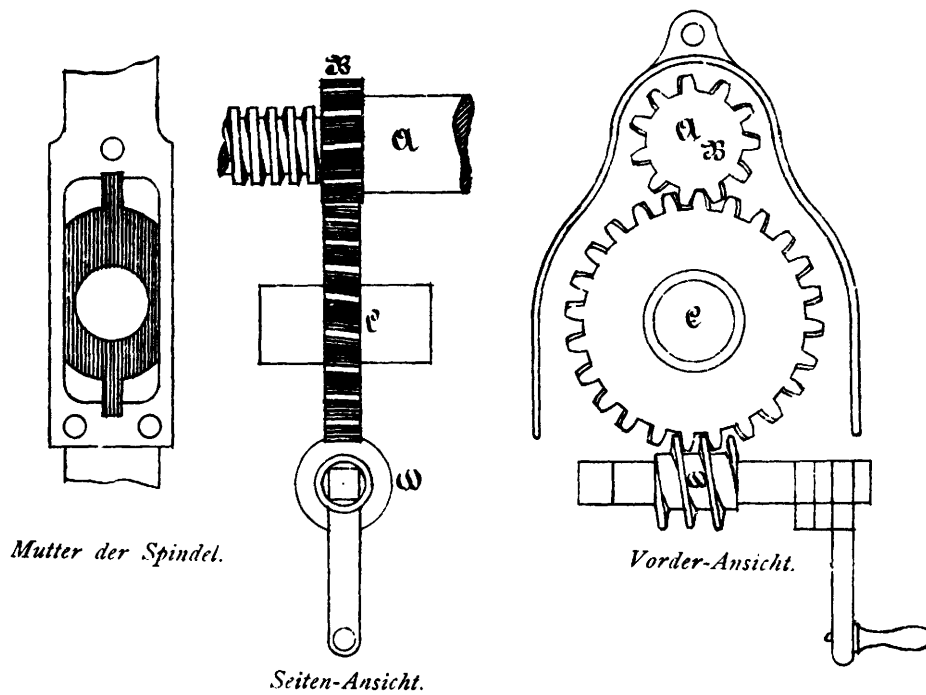

Zu der Patentschrift

**№ 165.**

PHOTOGR. DRUCK DER KÖNIGL. PREUSS. STAATSDRUCKEREI.



MAX GRITZNER IN DURLACH.

Selbstthätige Fadenführung an Spulapparaten für Nähmaschinen mit Schiffschen.

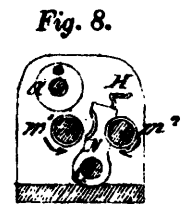
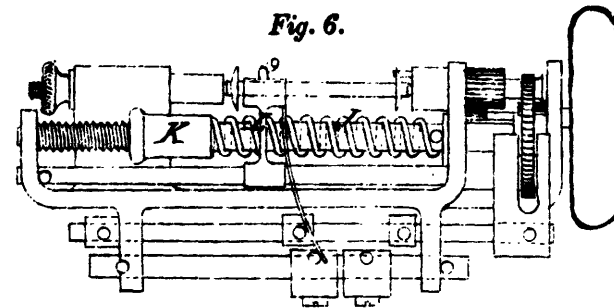
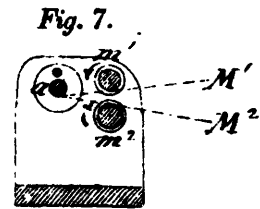
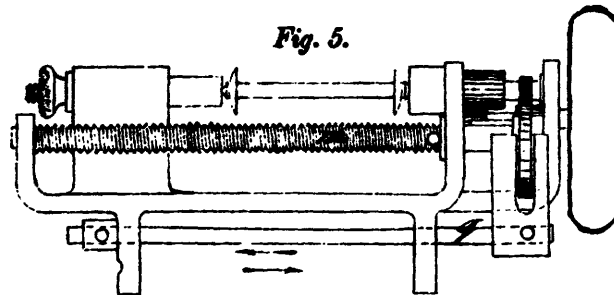
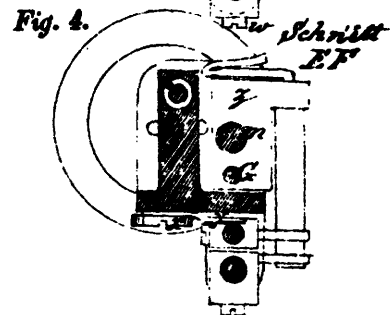
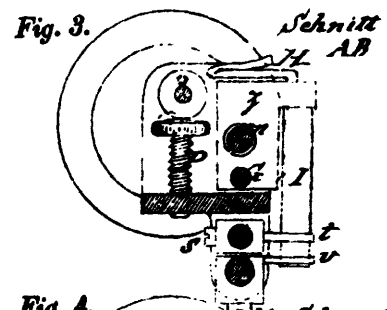
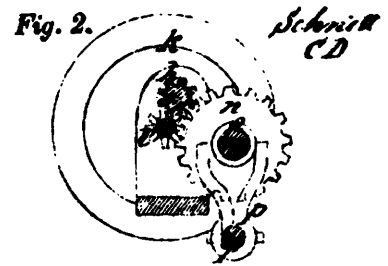
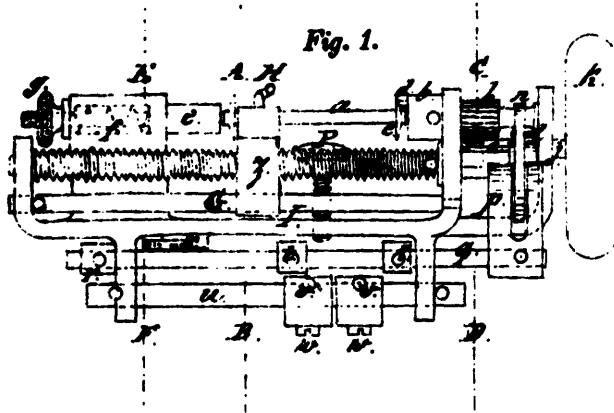

Zu der Patentschrift

№ 105.

PHOTOGR. DRUCK DER KÖNIGL. PREUSS. STAATSDRUCKEREI.

PROPORTION OF TOTAL PAT. APPL. IN 1/1000 IN THE CLASS 19

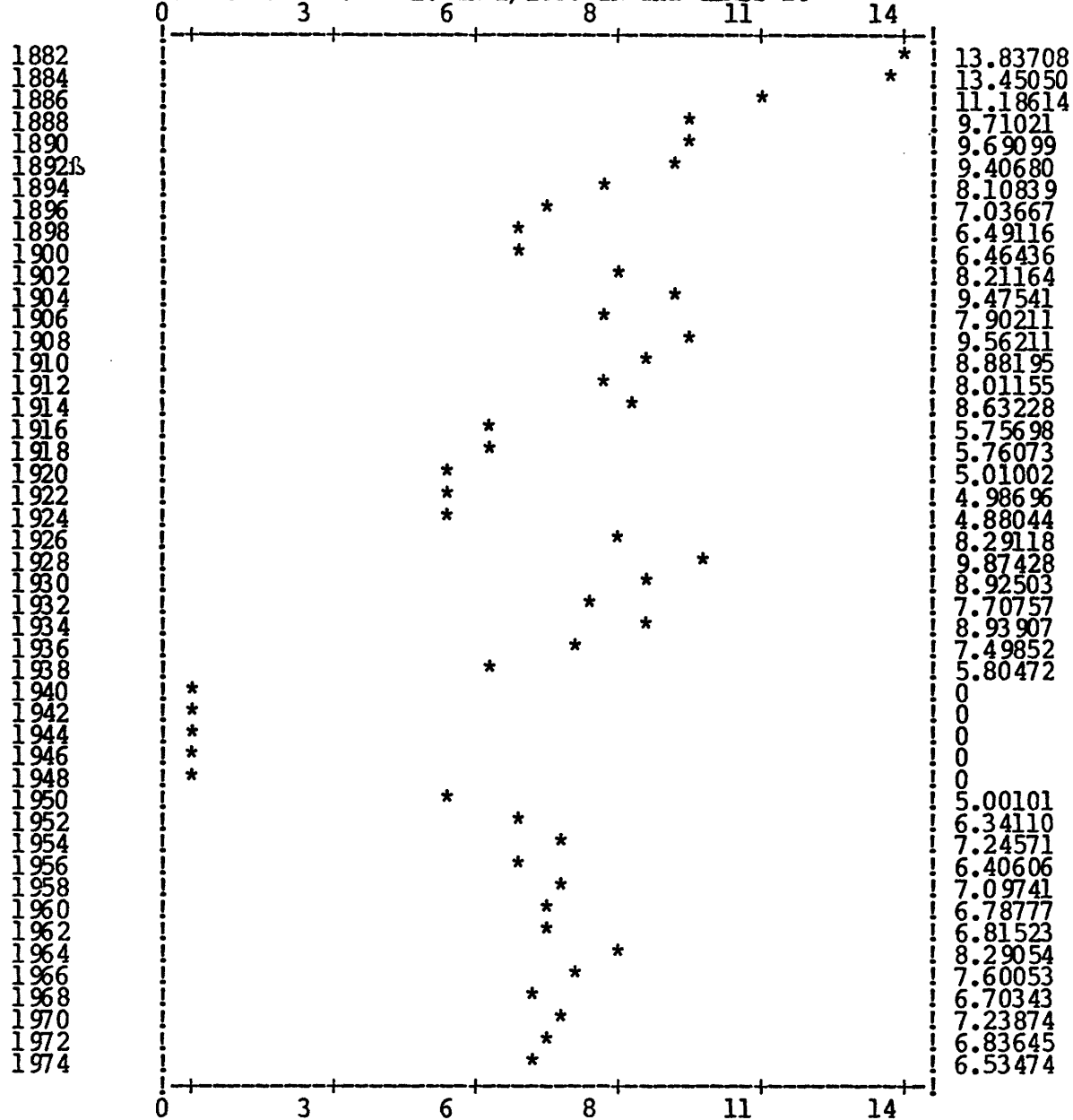

C1. 20 Railway transport

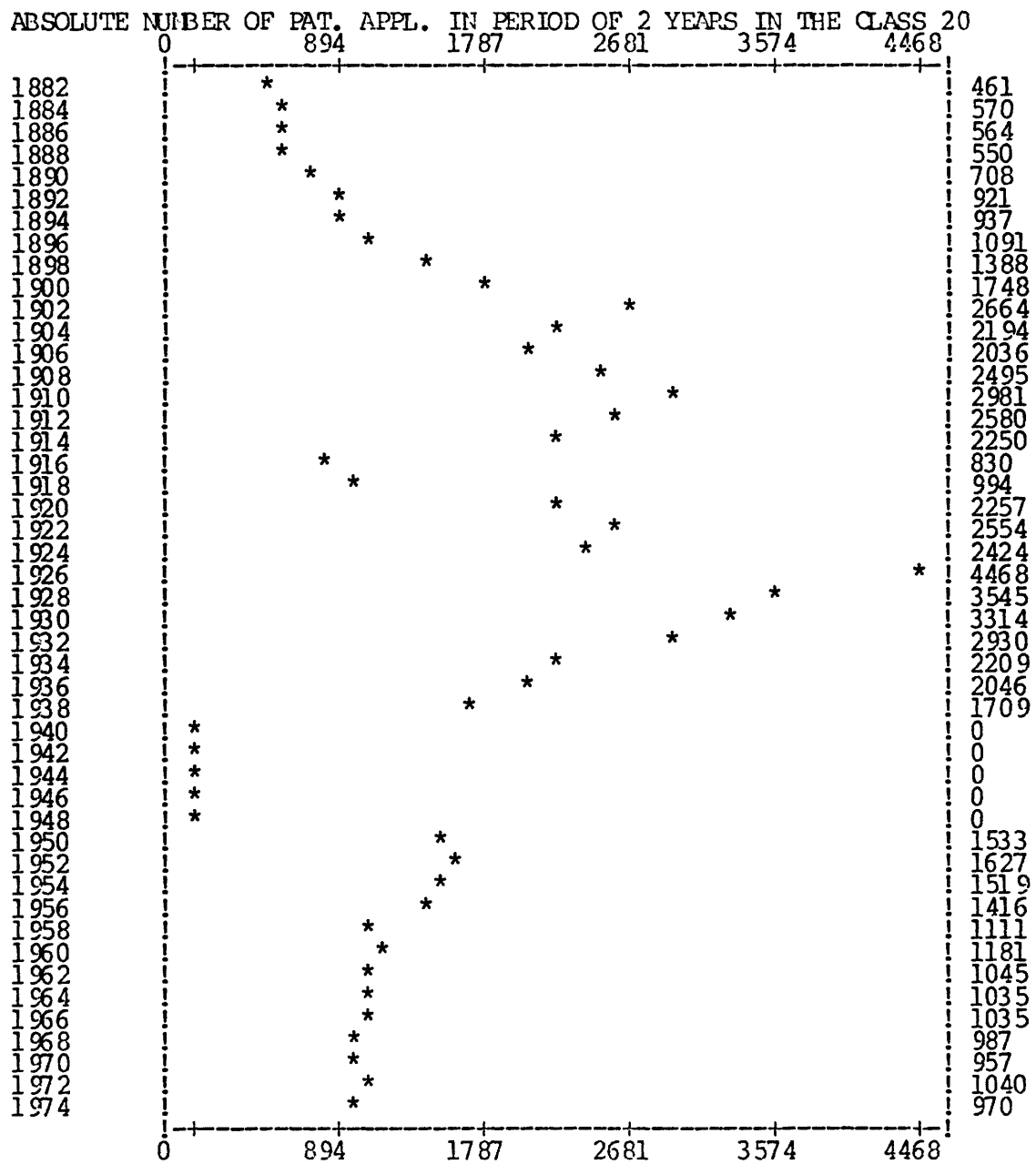

PROPORTION OF TOTAL PAT. APPL. IN 1/1000 IN THE CLASS 20

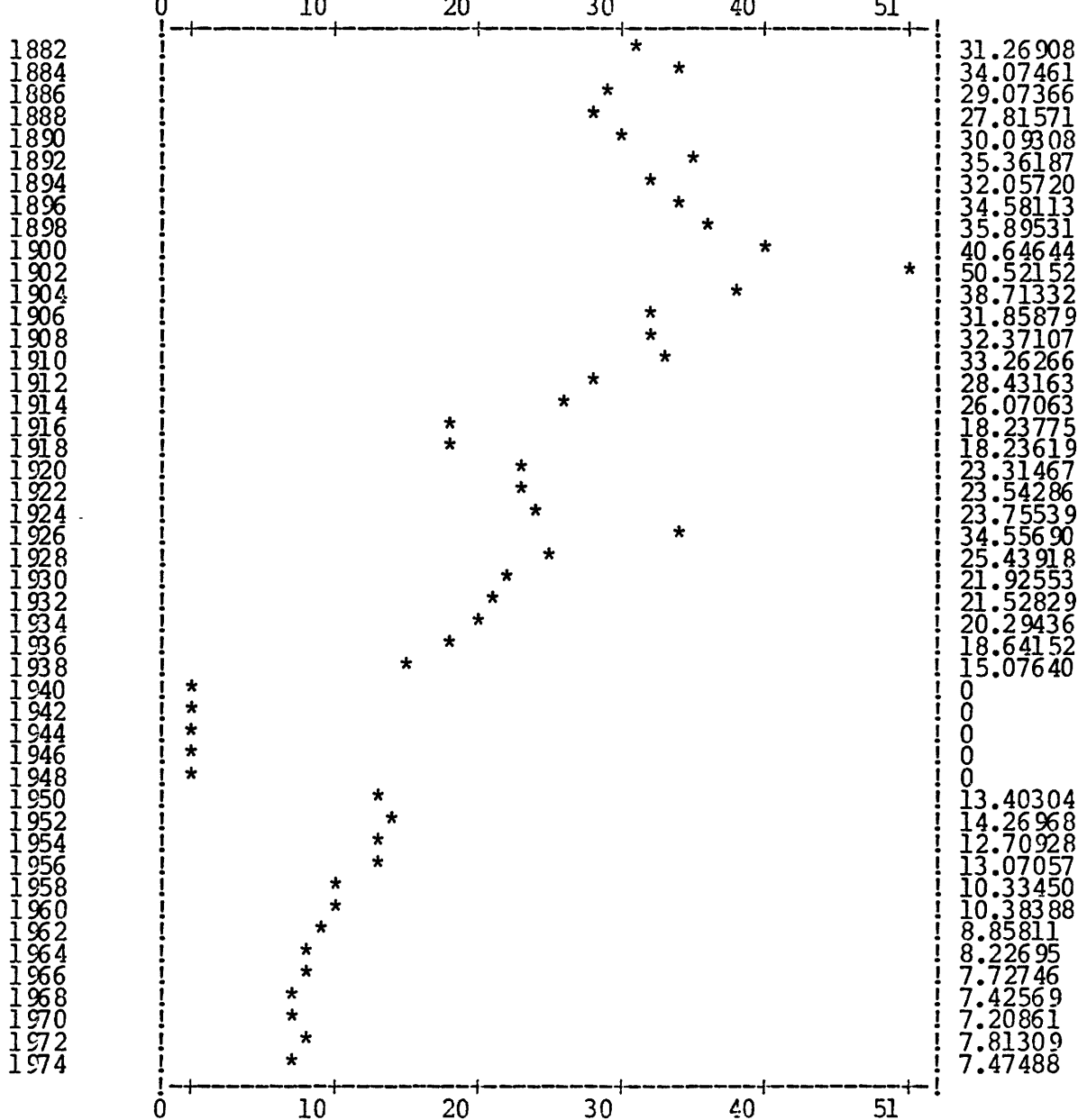

Cl. 21 Electrical engineering

ABSOLUTE NUMBER OF PAT. APPL. IN PERIOD OF 2 YEARS IN THE CLASS 21

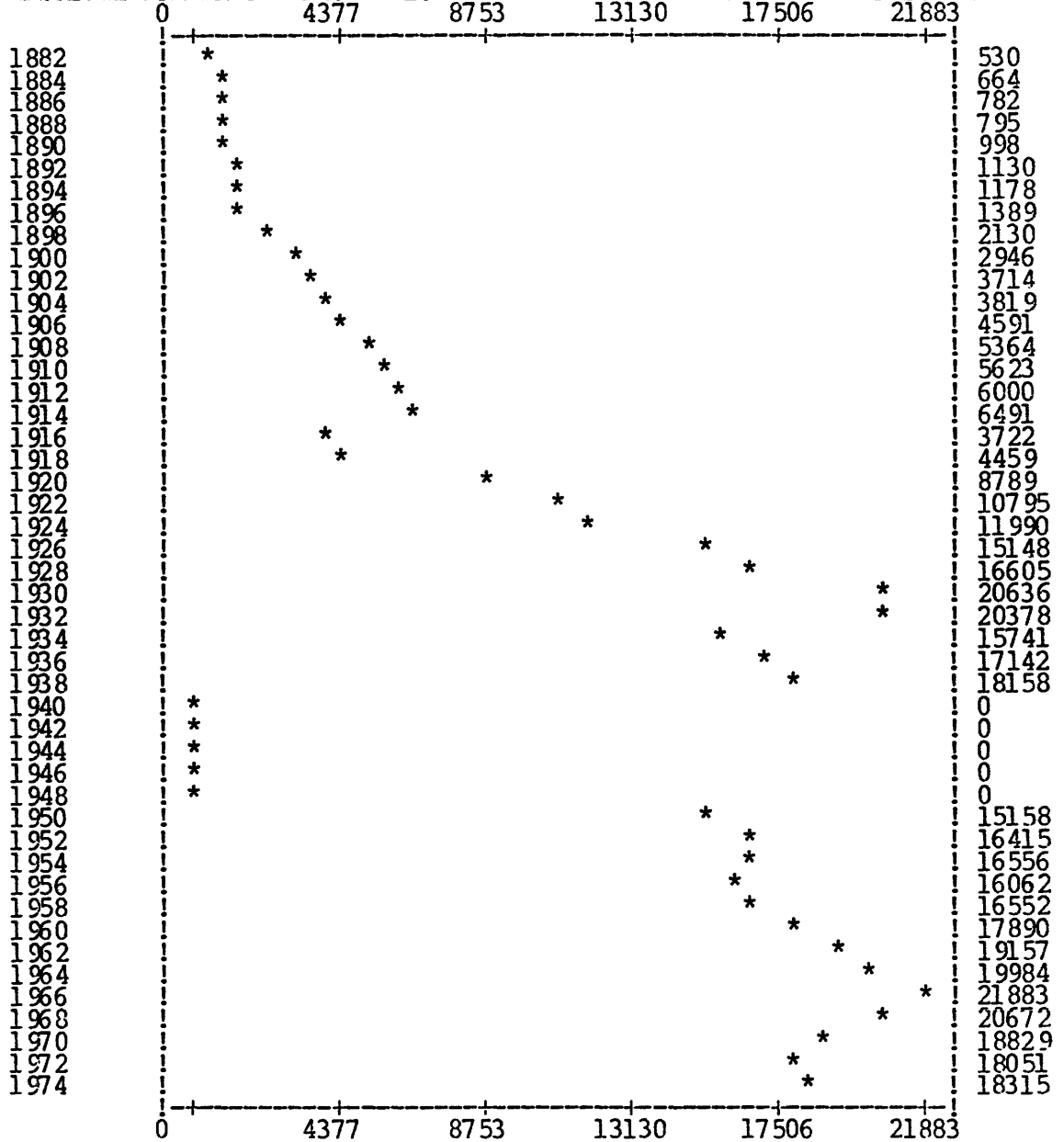

PROPORTION OF TOTAL PAT. APPL. IN 1/1000 IN THE CLASS 21

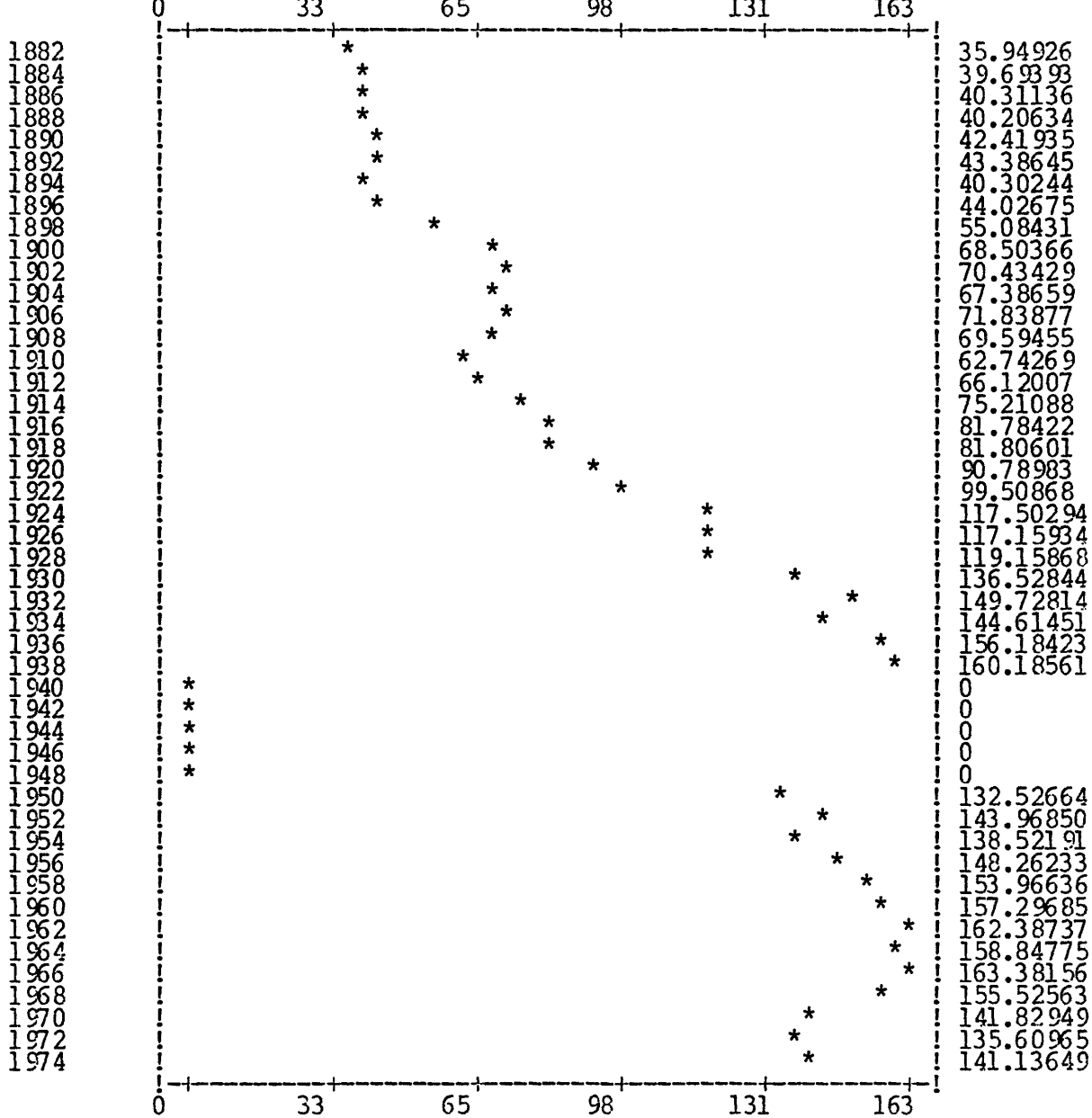

C1. 22 Dyes; paints, polishes; natural resins; adhesives; miscellaneous compositions; miscellaneous applications of material

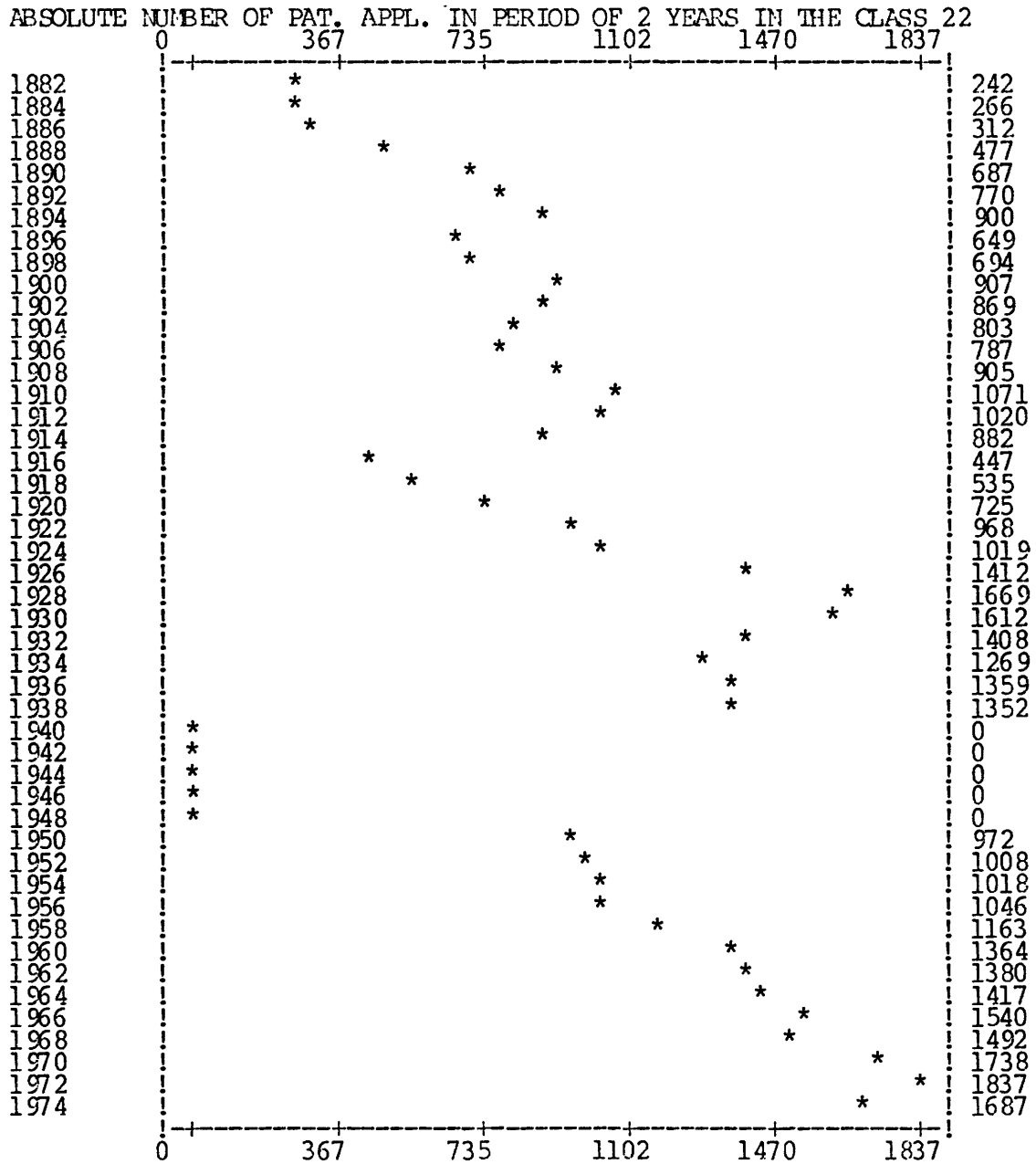

PROPORTION OF TOTAL PAT. APPL. IN 1/1000 IN THE CLASS 22

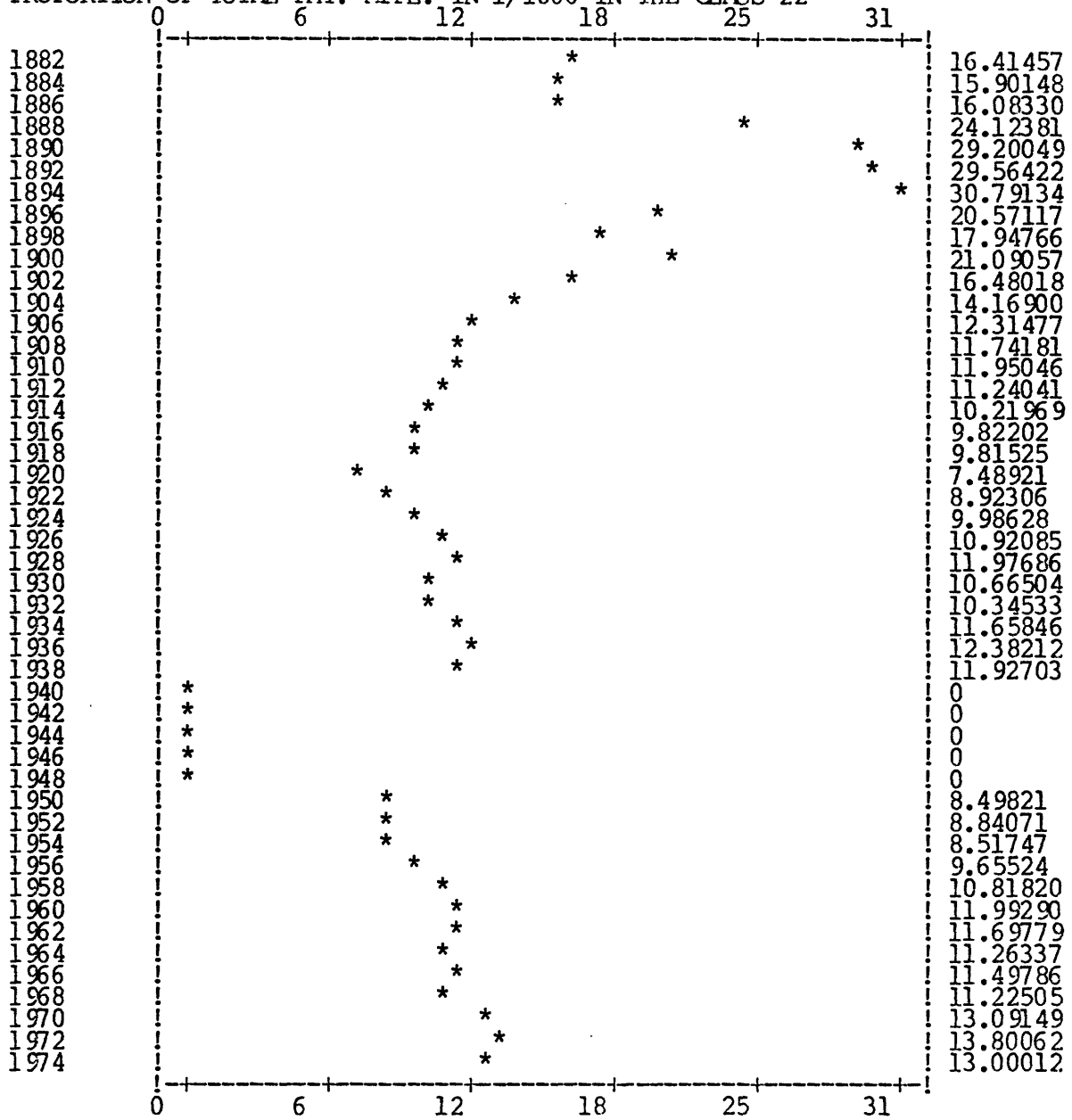



Cl. 23 Oils and fats

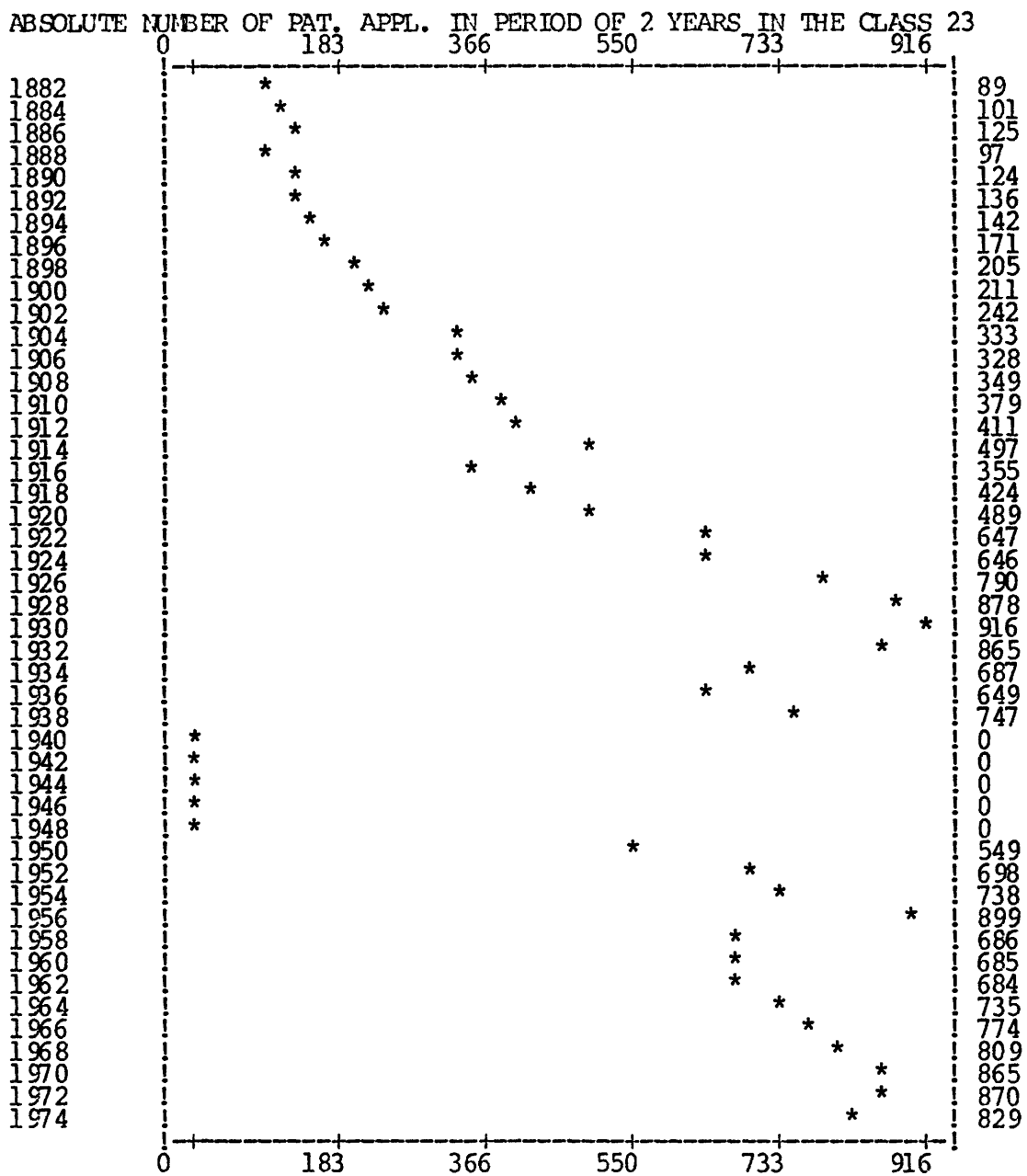

PROPORTION OF TOTAL PAT. APPL. IN 1/1000 IN THE CLASS 23

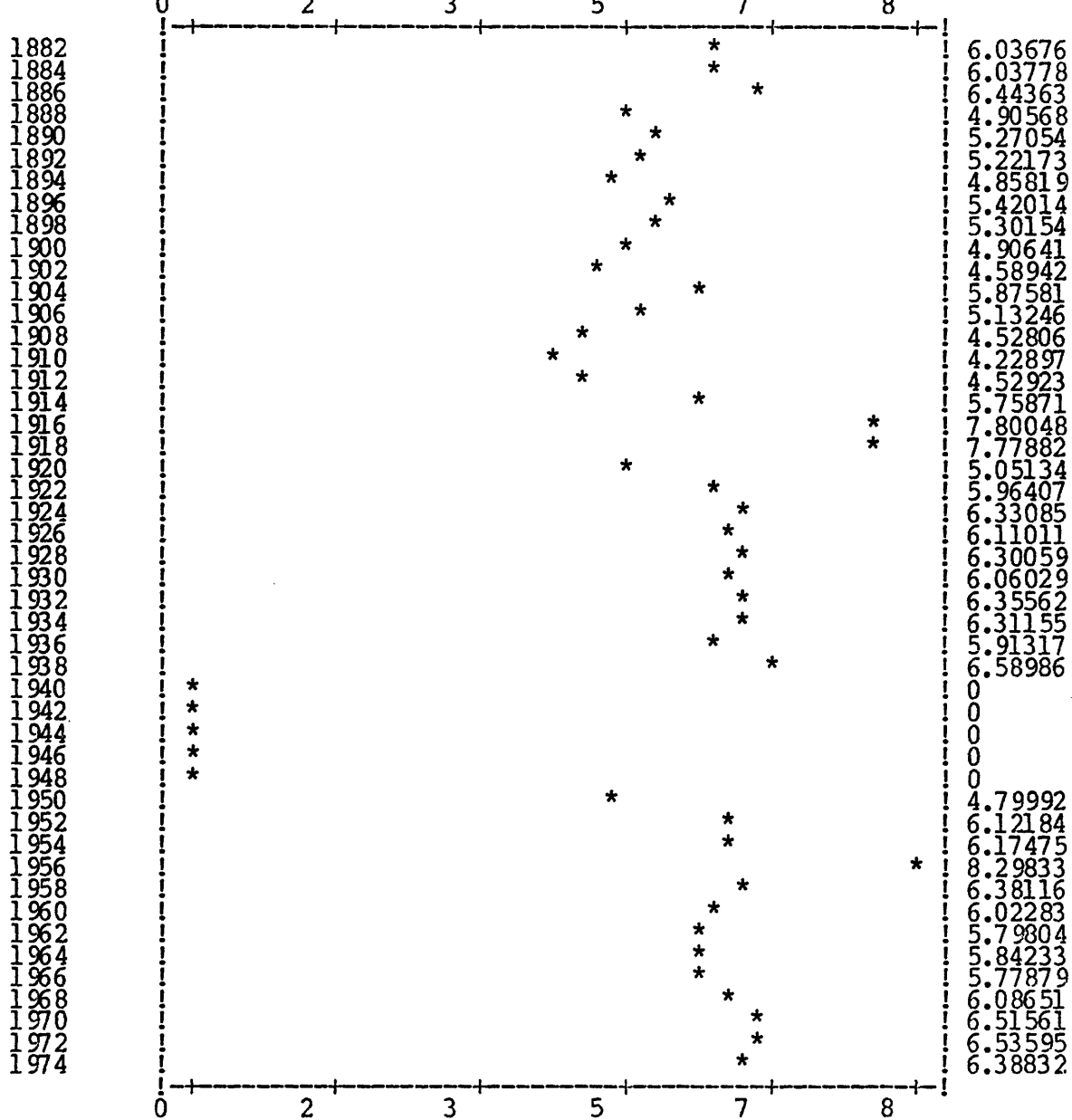

Cl. 24 Furnaces etc.

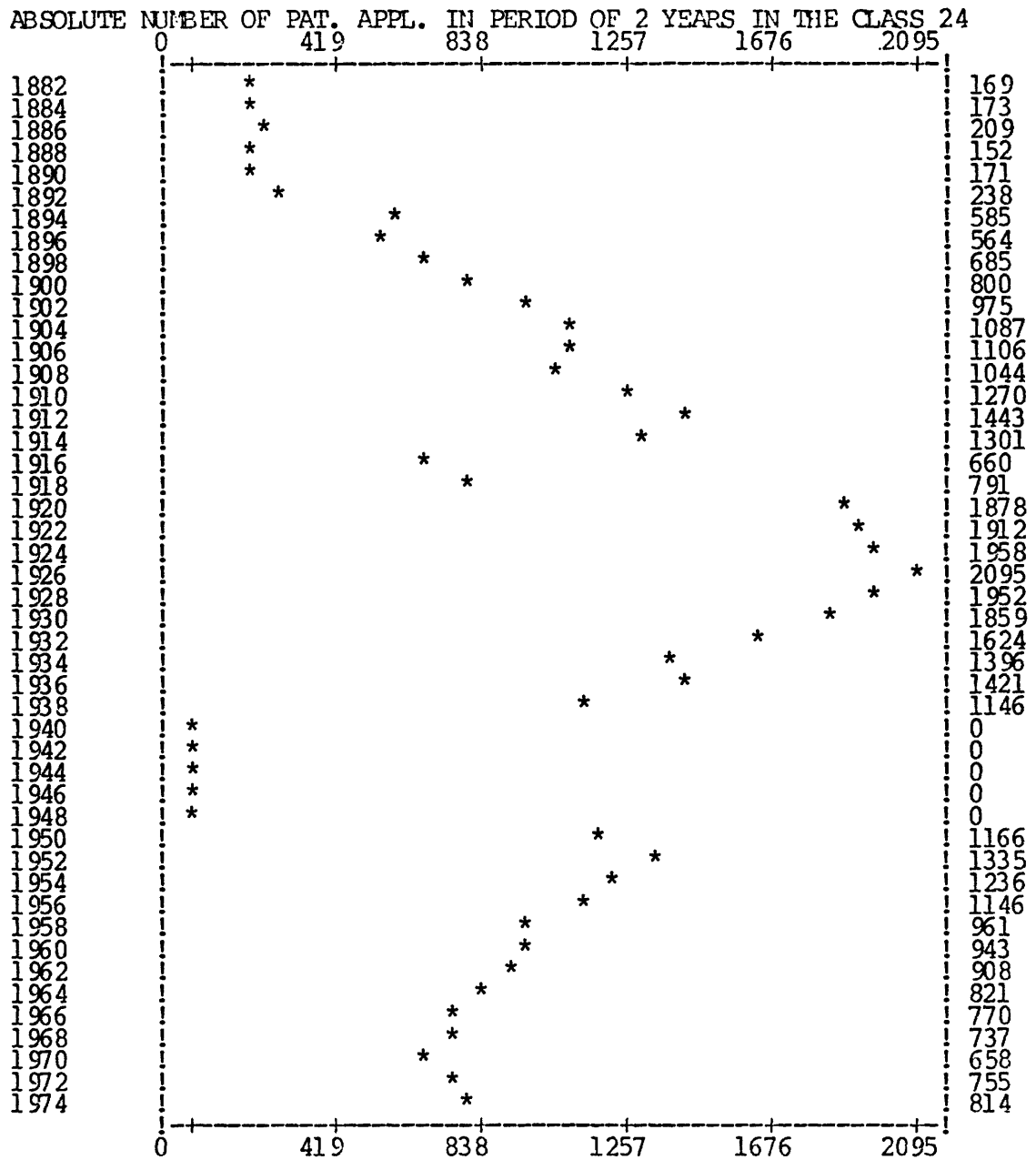

PROPORTION OF TOTAL PAT. APPL. IN 1/1000 IN THE CLASS 24

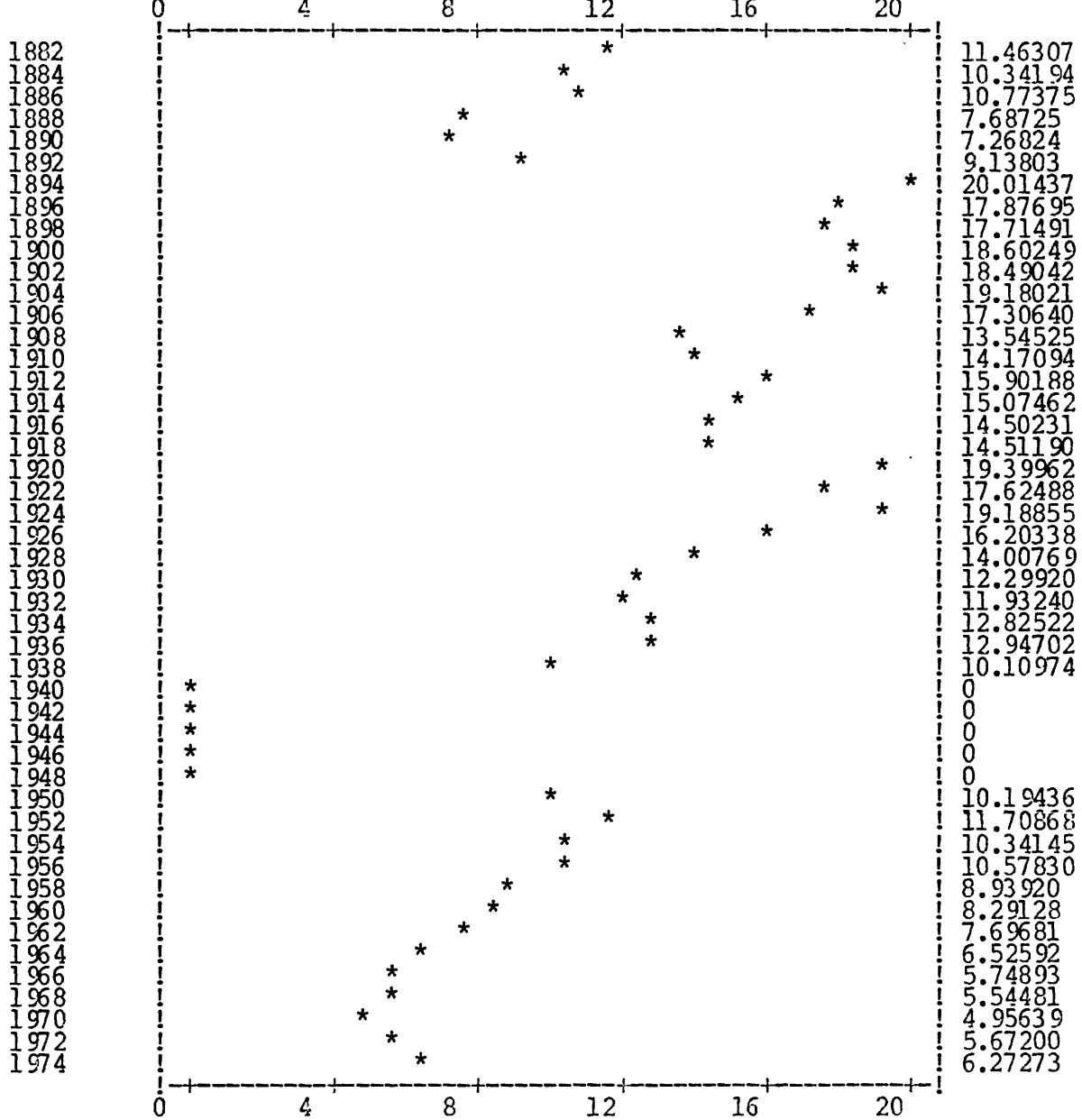

Cl. 25 Braiding, lace-making, knitting, trimmings, non-woven fabrics

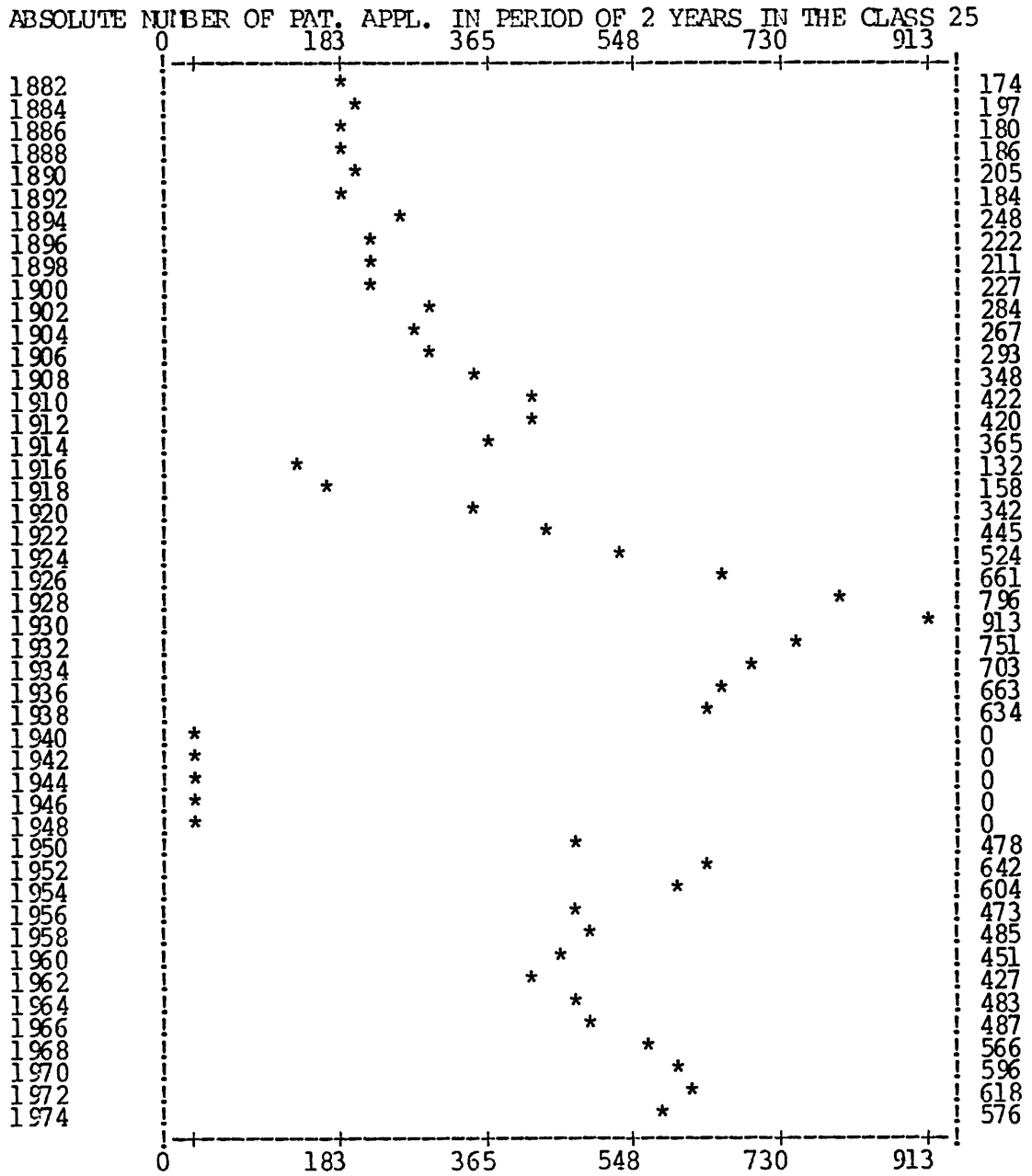

PROPORTION OF TOTAL PAT. APPL. IN 1/1000 IN THE CLASS 25

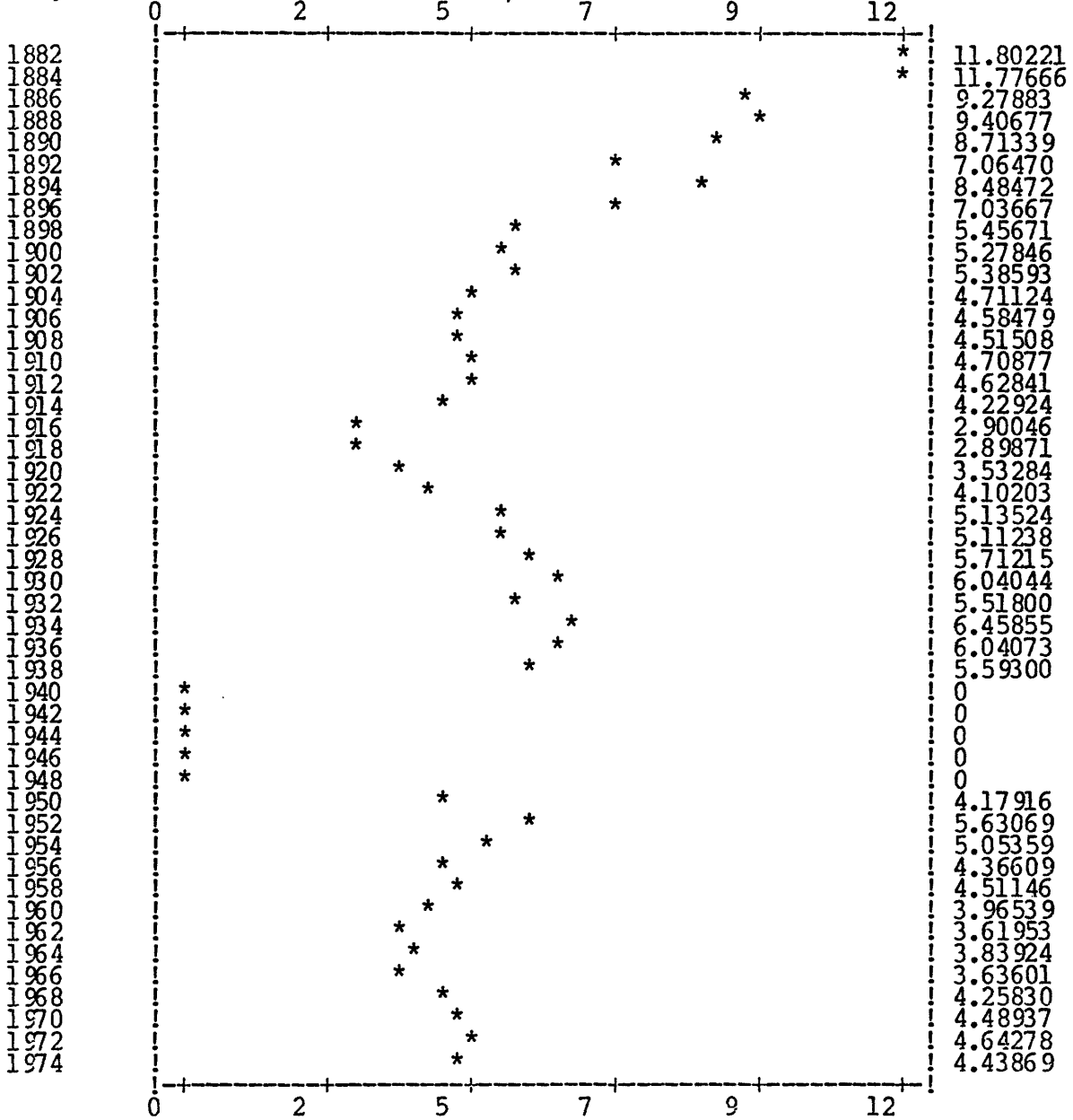

Cl. 26 Production of gases by the degasification of fuels, e.g. natural gas and oil gas; production of gaseous fuels by carburation; distillation gas and acetylene cleaning

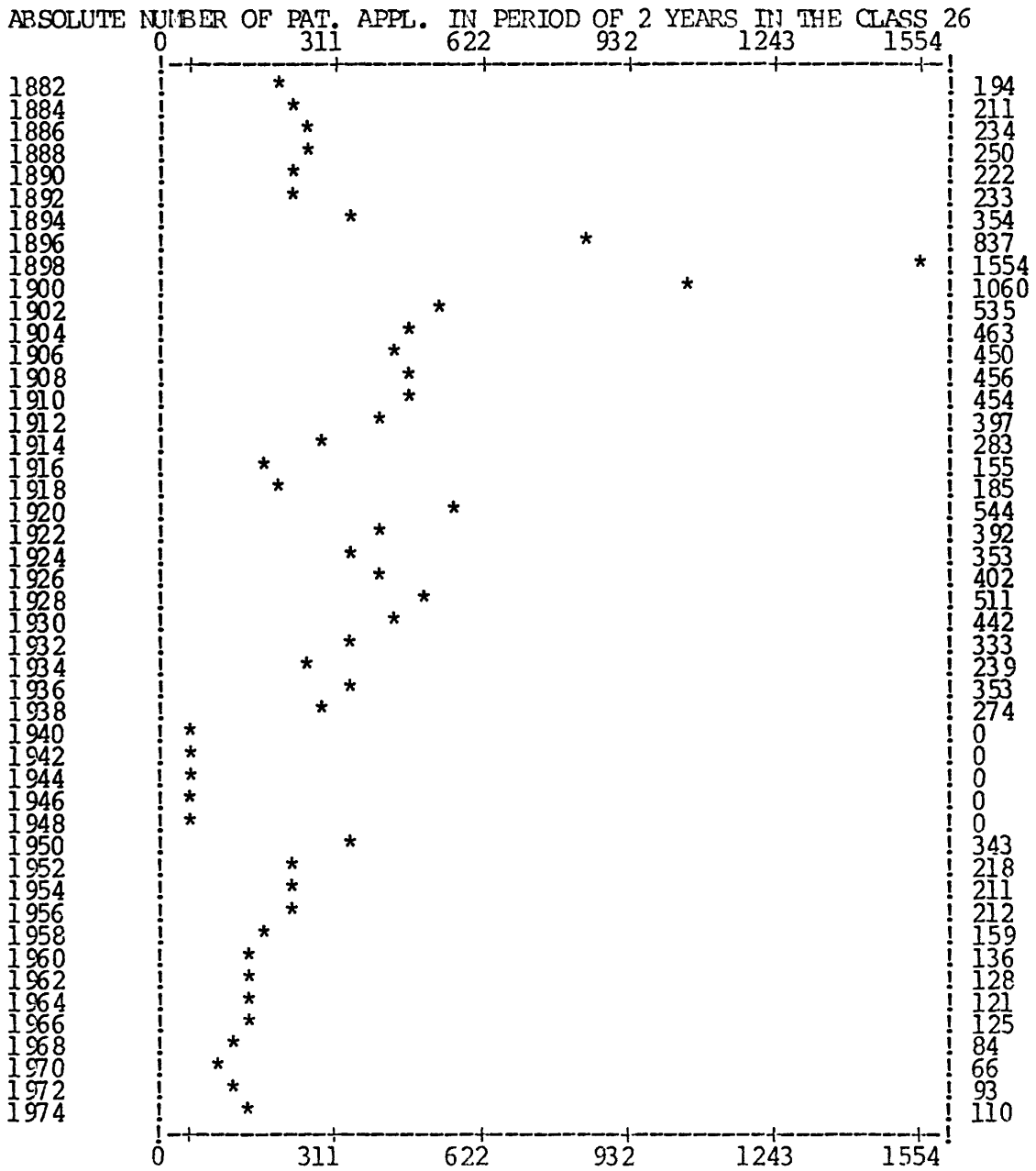

PROPORTION OF TOTAL PAT. APPL. IN 1/1000 IN THE CLASS 26

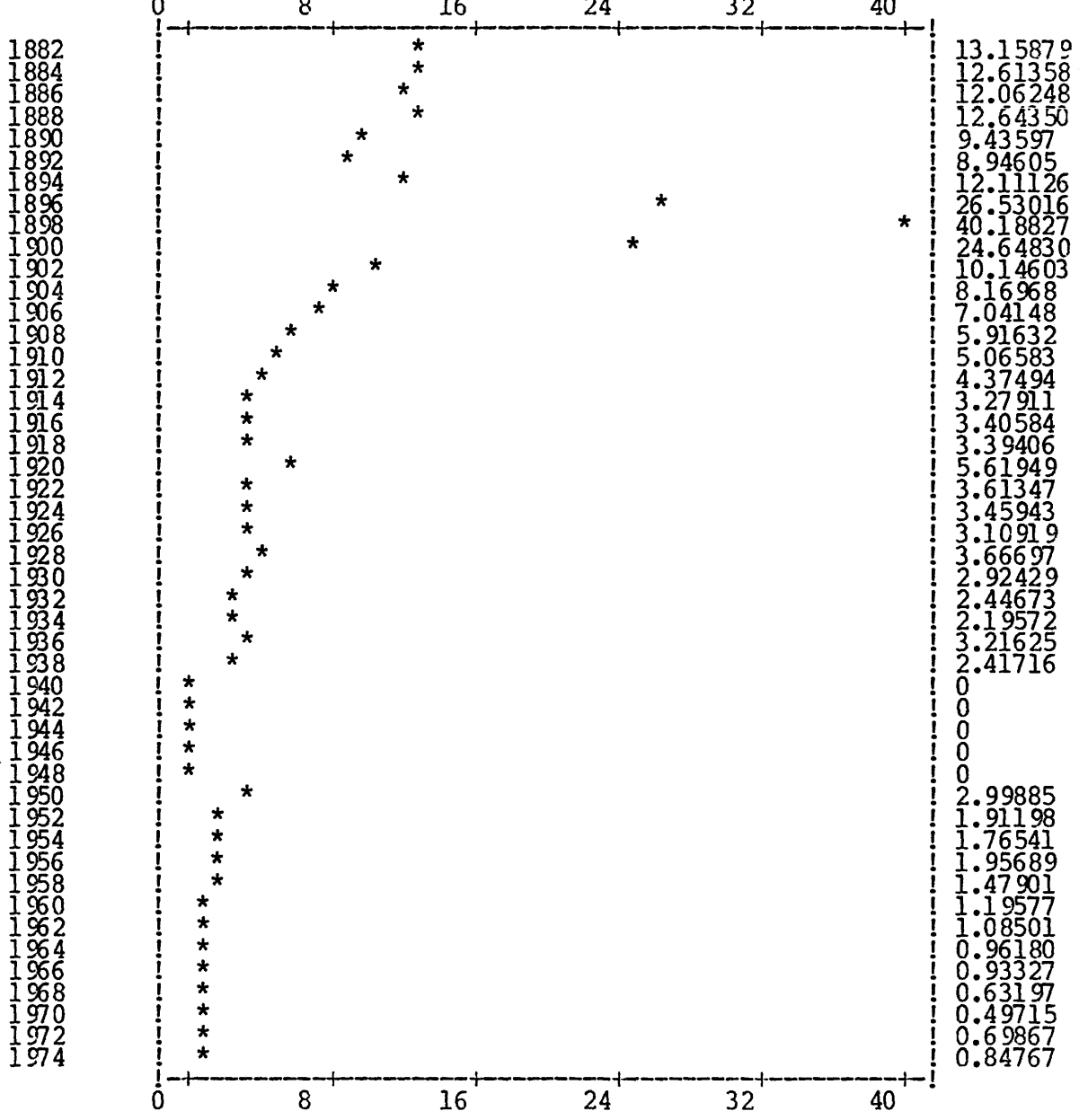



Cl. 27 Fans, air pumps and compressors

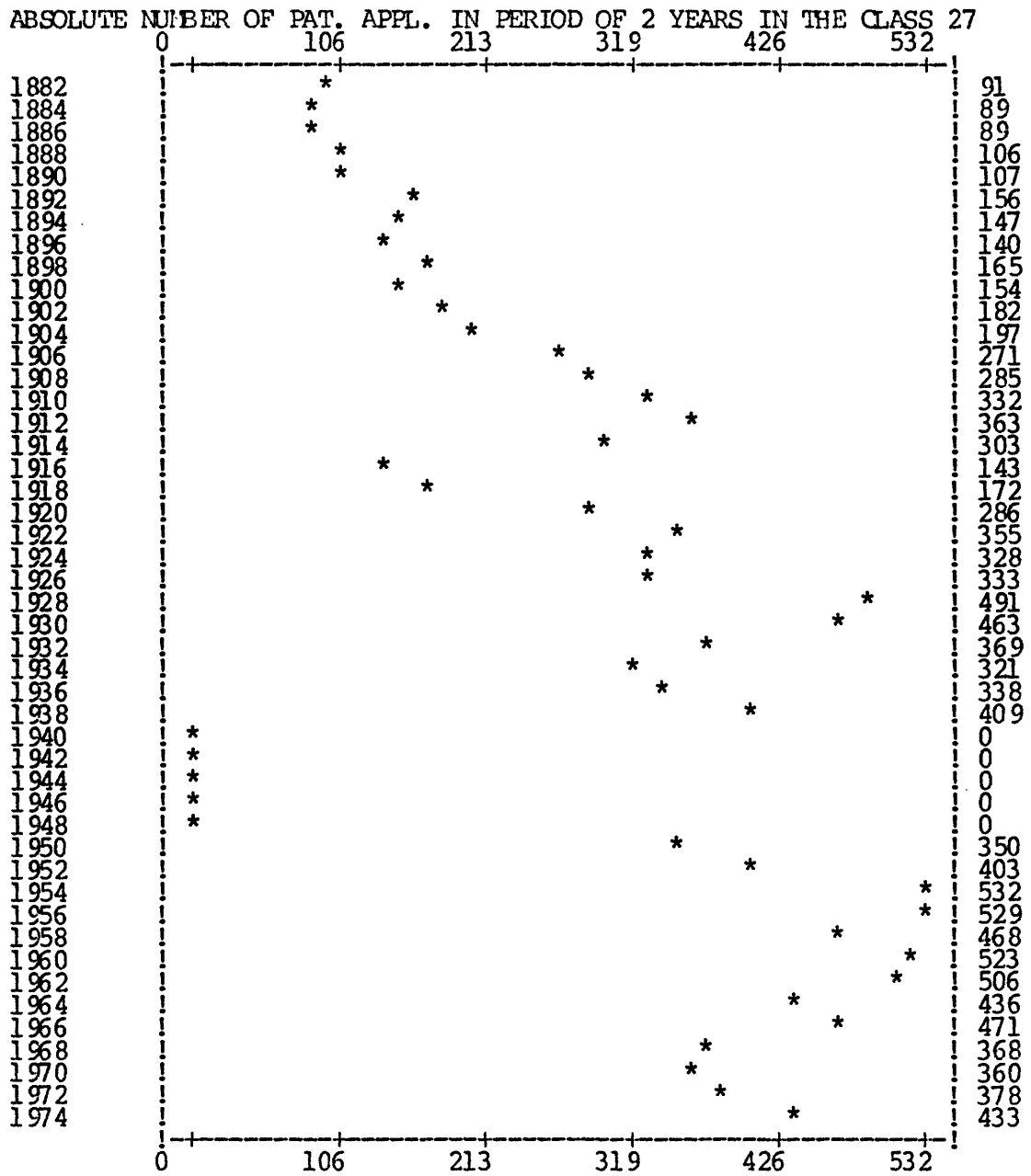

PROPORTION OF TOTAL PAT. APPL. IN 1/1000 IN THE CLASS 27

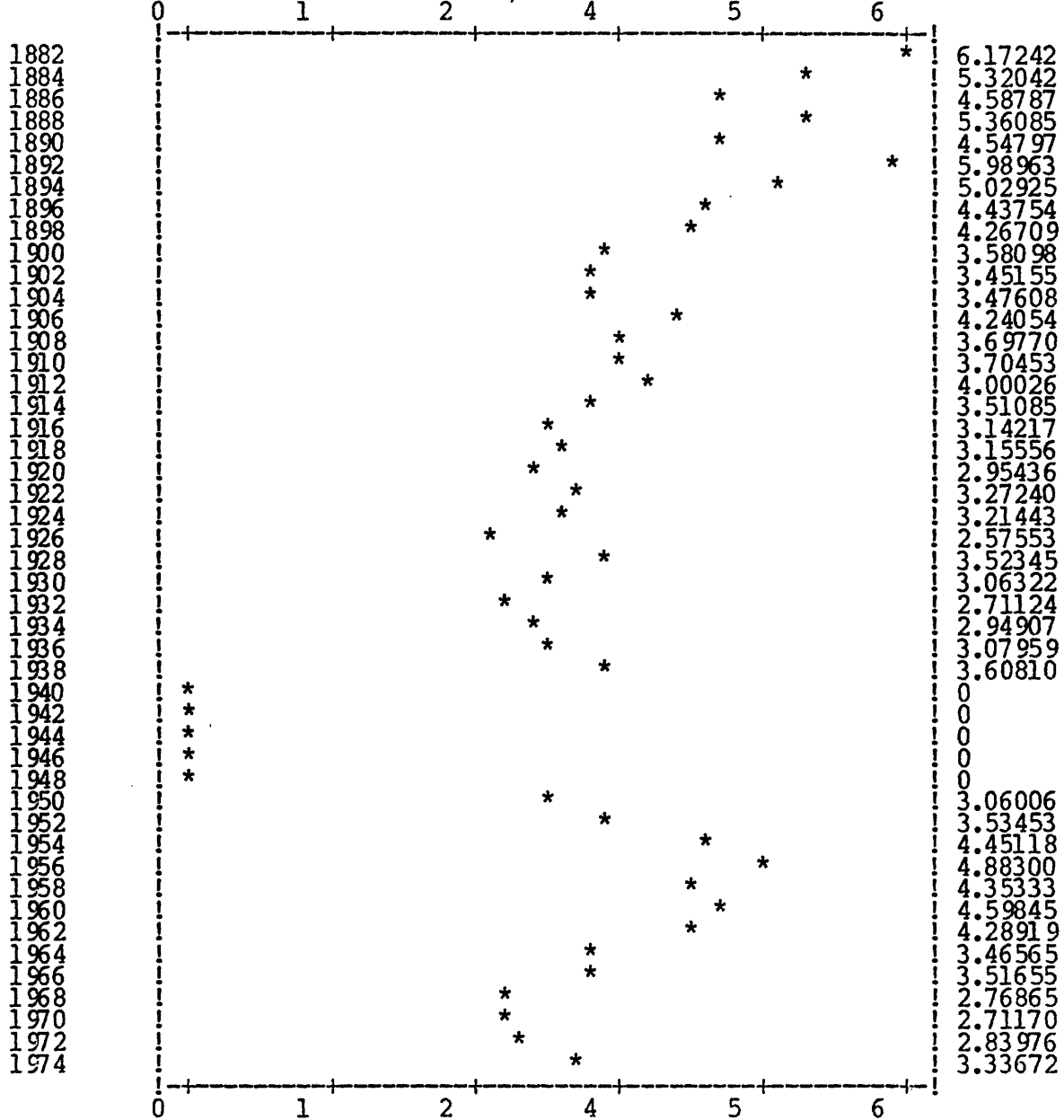

Cl. 28 Tanning and treatment of skins and hides, leather industry

ABSOLUTE NUMBER OF PAT. APPL. IN PERIOD OF 2 YEARS IN THE CLASS 28

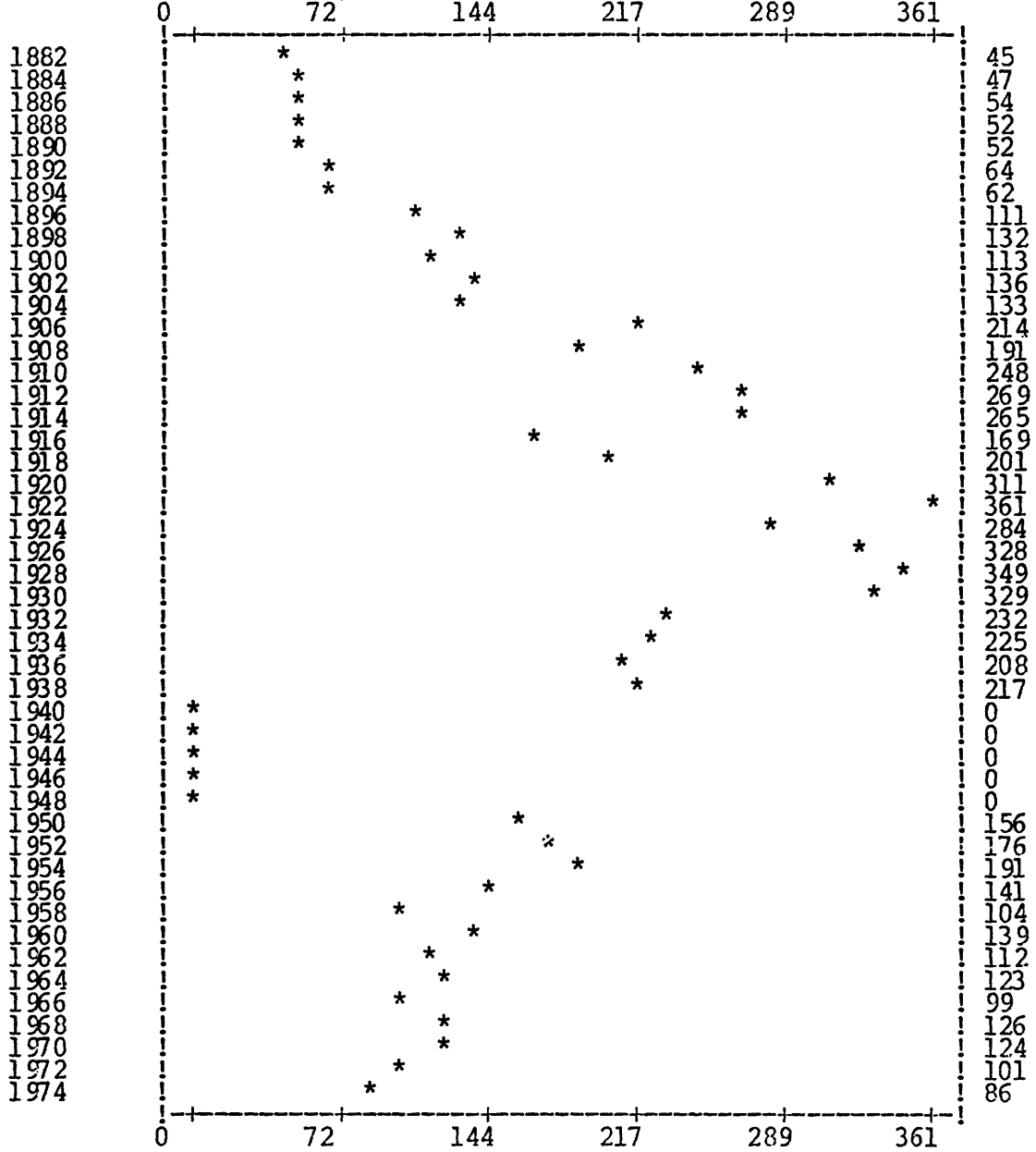

G. A. KÄSTNER IN PLAGWITZ.

**Gummipolster für Pferdehufe, welches den Strahl nicht deckt.**

*Fig. 1.*

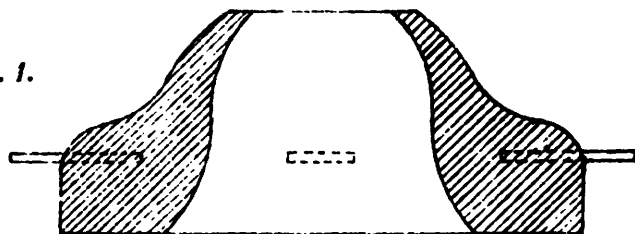

*Fig. 2.*

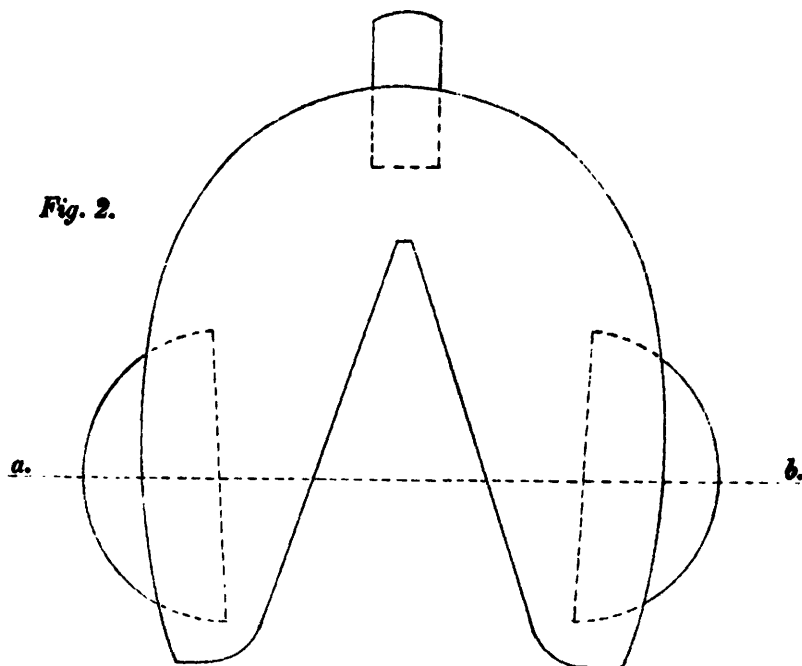

*Fig. 3.*

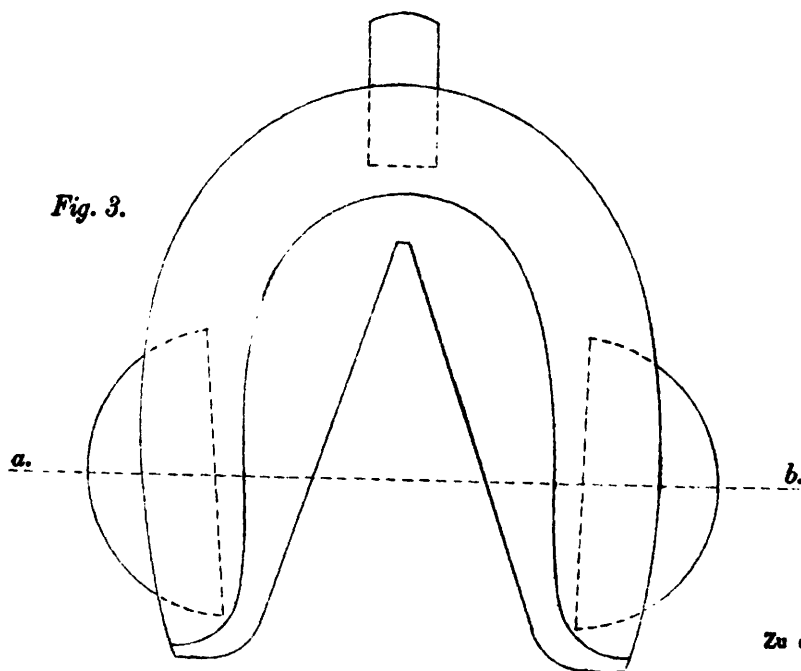

Zu der Patentschrift

**№ 92.**

PHOTOGR. DRUCK DER KÖNIGL. PREUSS. STAATSDRUCKEREI.

Fig. 1.

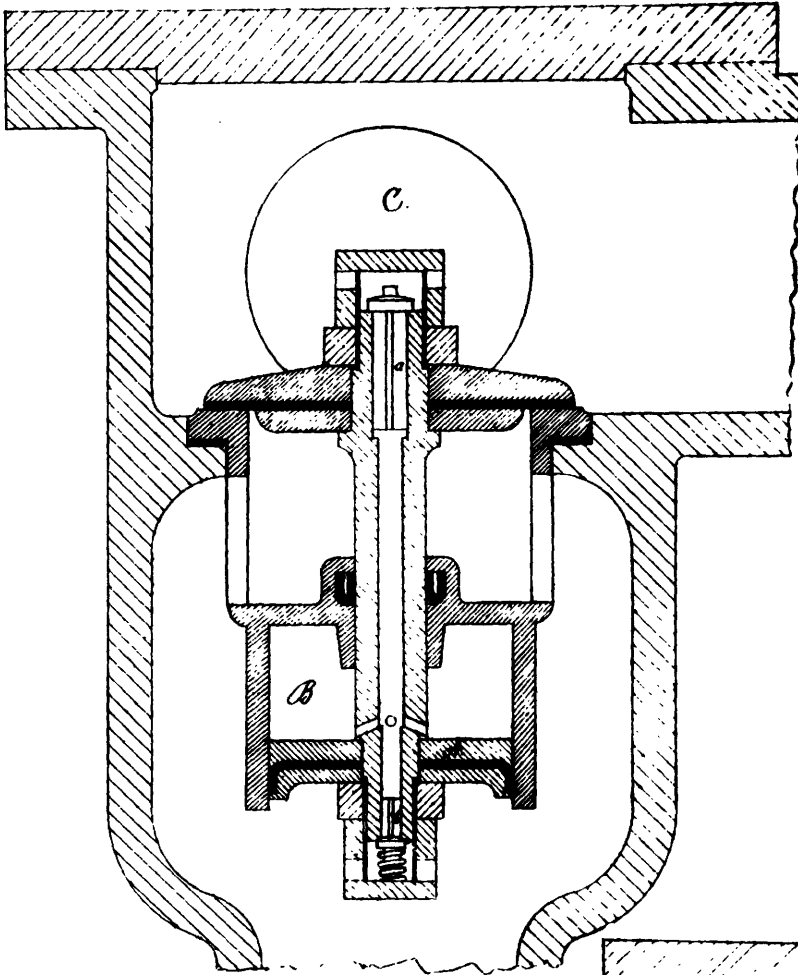
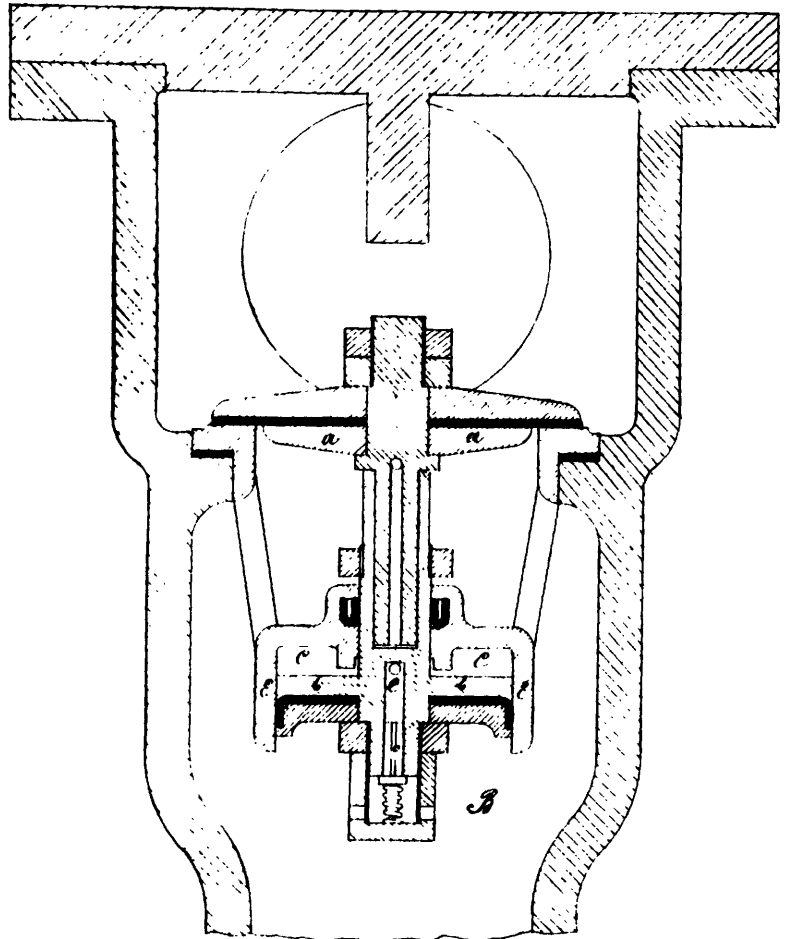

Fig. 2.



Zu der Patentschrift

№ 199.

PROPORTION OF TOTAL PAT. APPL. IN 1/1000 IN THE CLASS 28

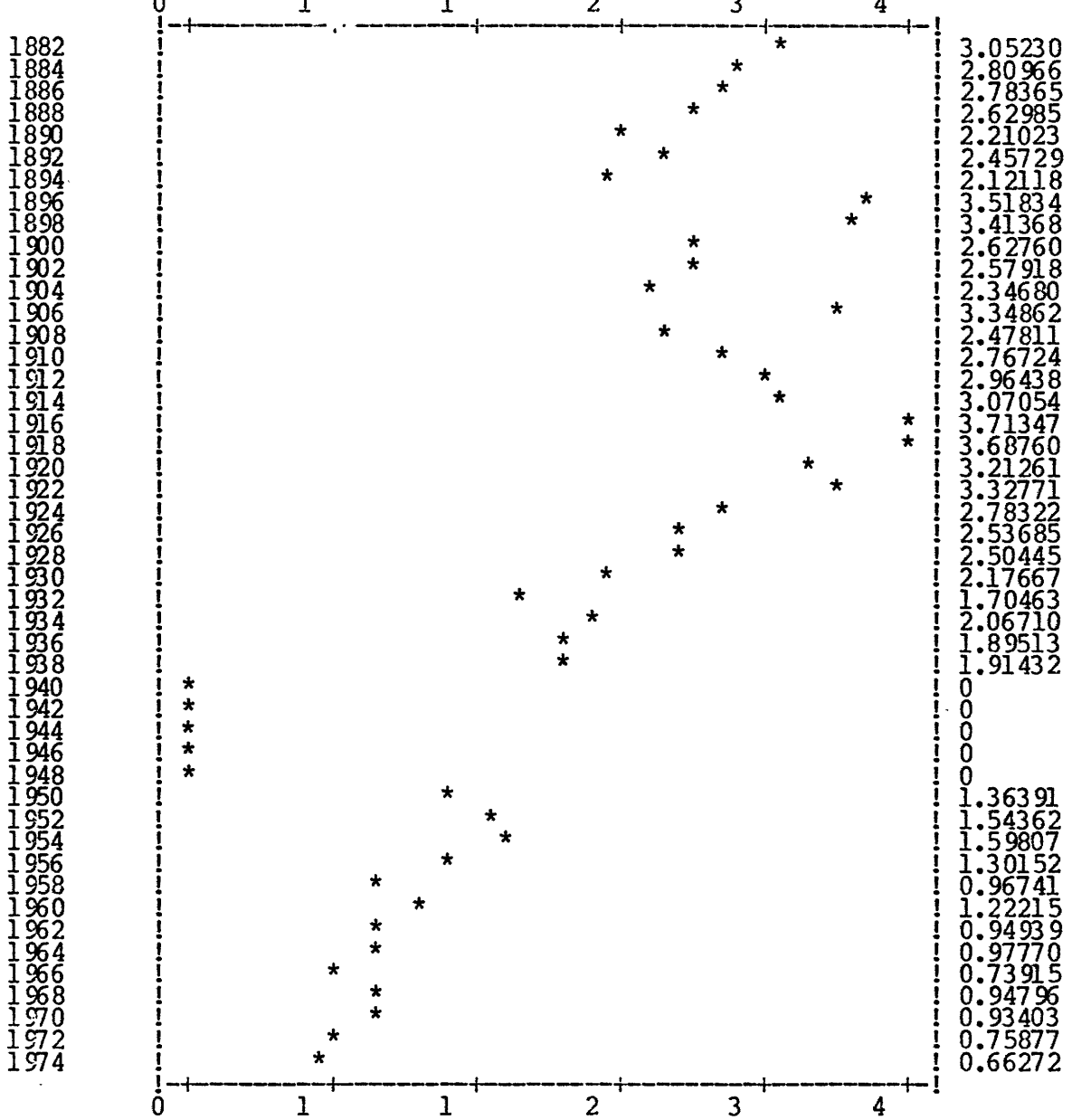

Cl. 29 Yarns

ABSOLUTE NUMBER OF PAT. APPL. IN PERIOD OF 2 YEARS IN THE CLASS 29

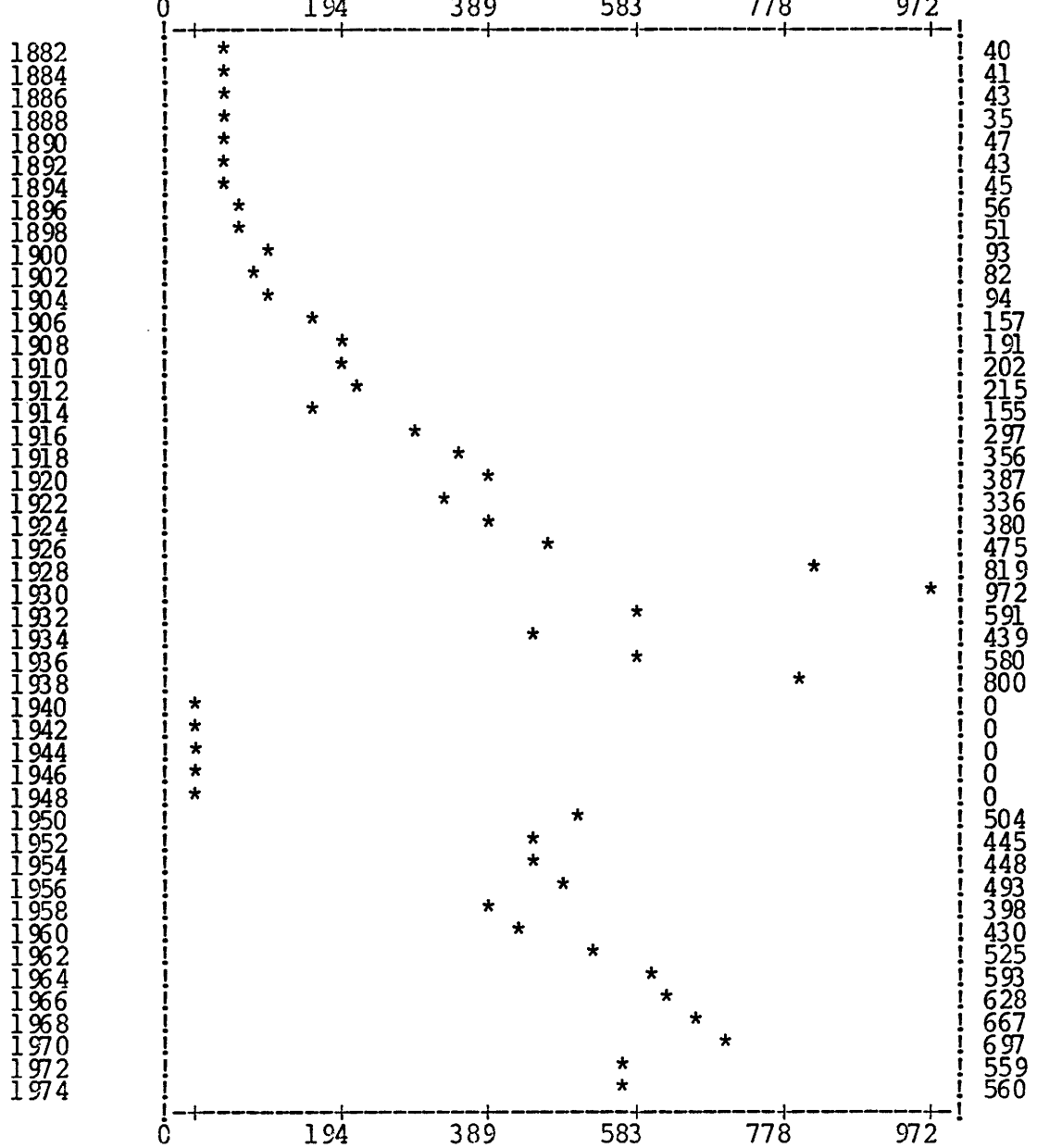

PROPORTION OF TOTAL PAT. APPL. IN 1/1000 IN THE CLASS 29

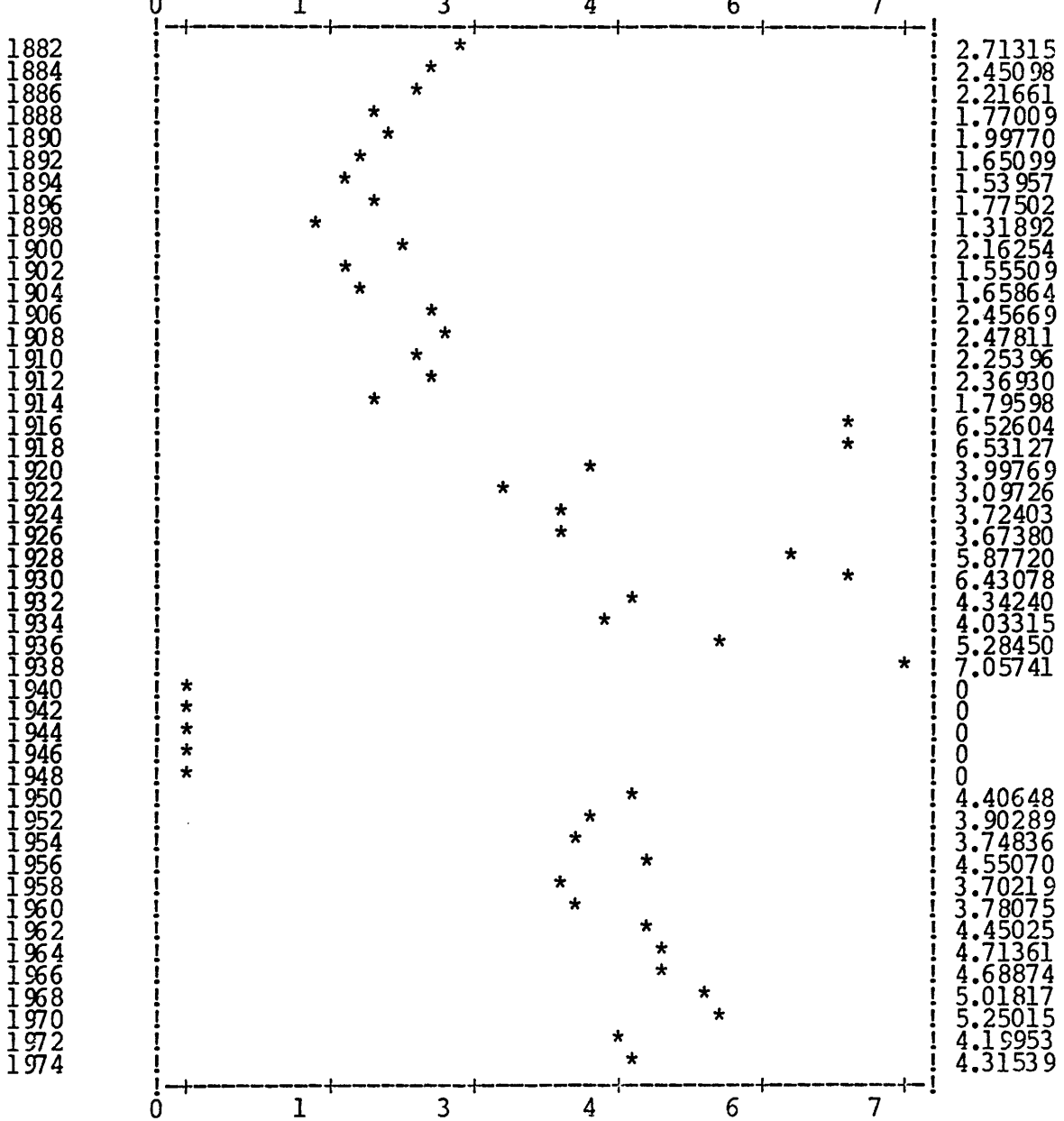



Cl. 30 Medical science

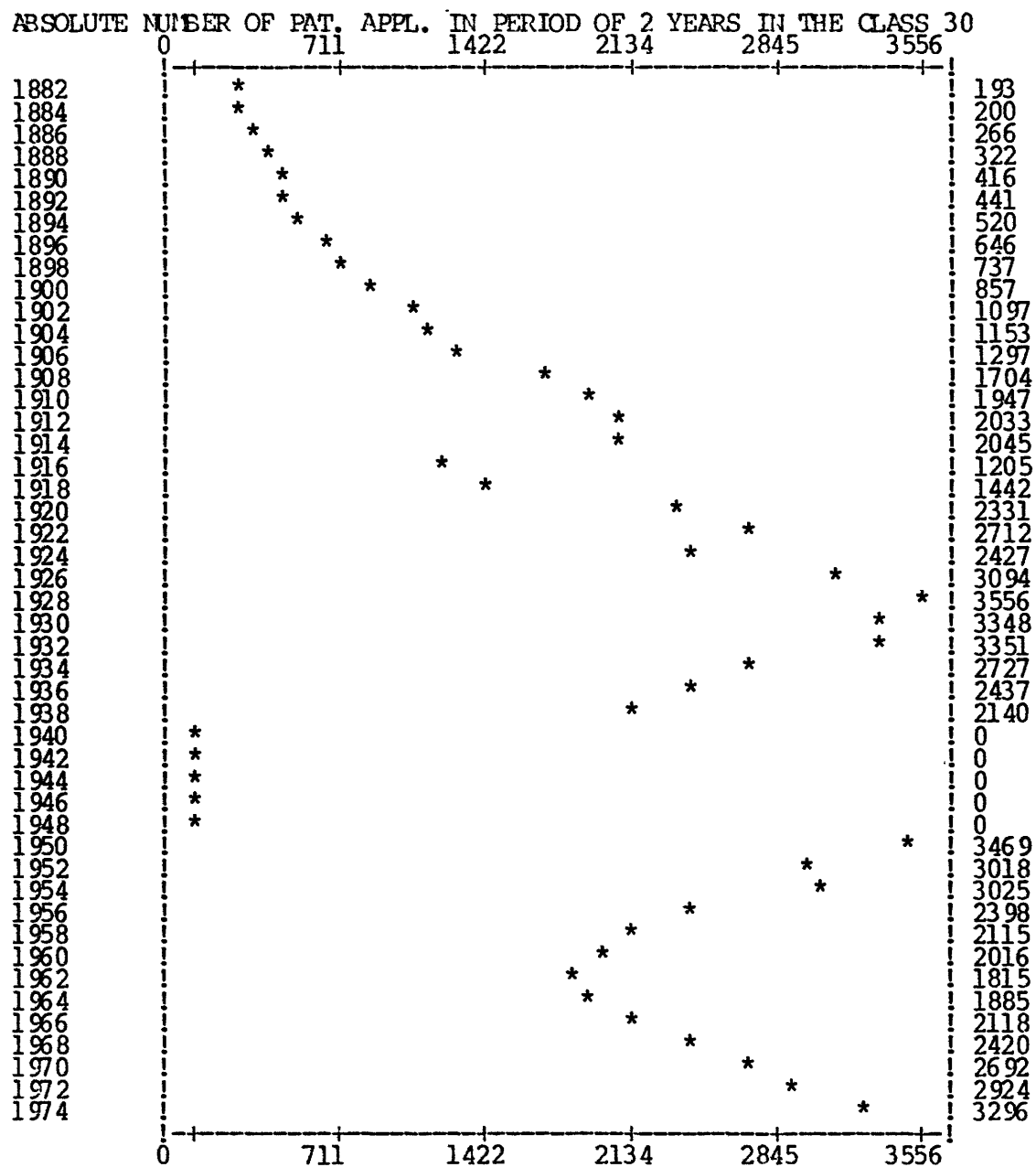

PROPORTION OF TOTAL PAT. APPL. IN 1/1000 IN THE CLASS 30

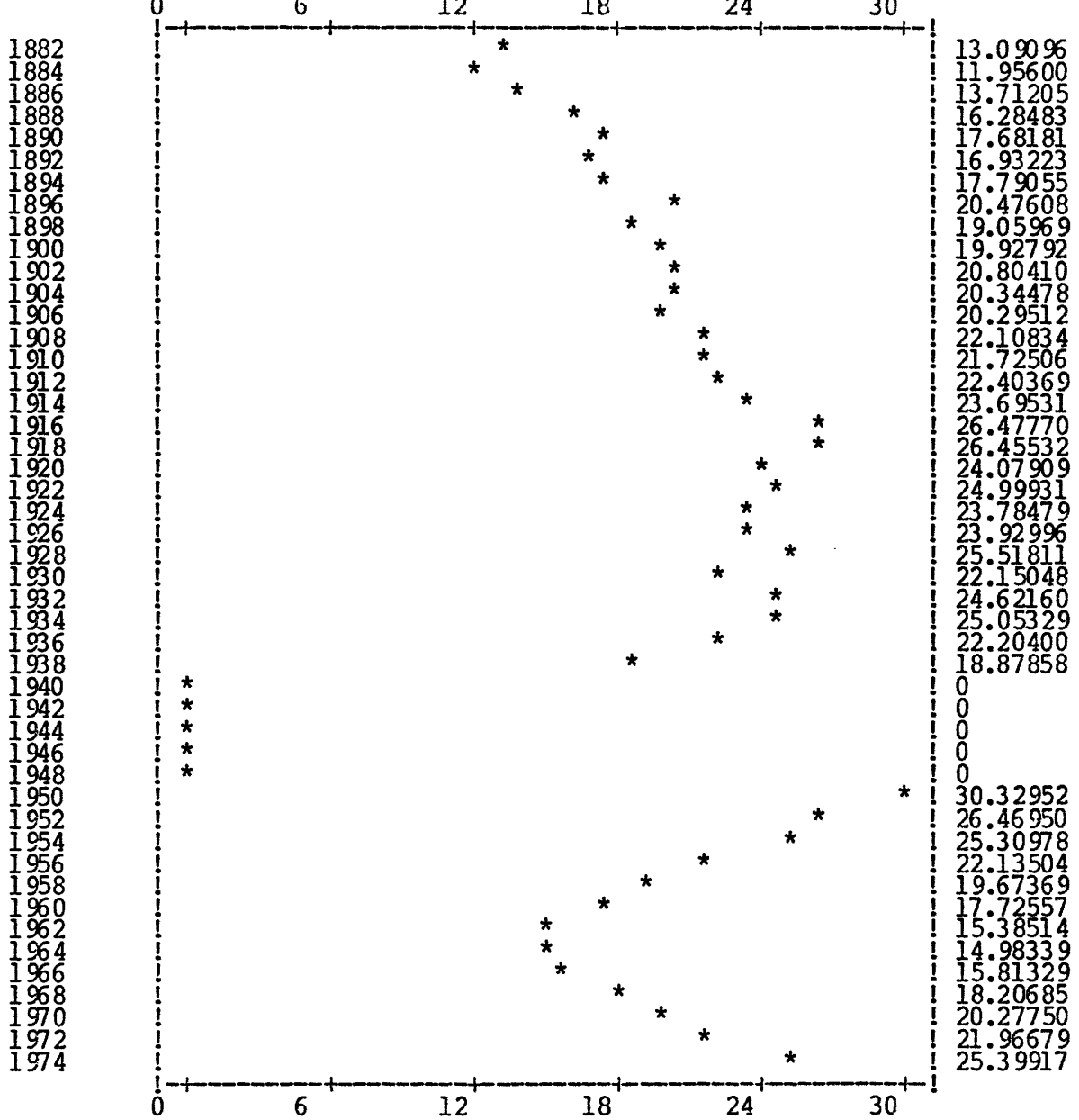

Cl. 31 Industrial furnaces; casting; powder metallurgy

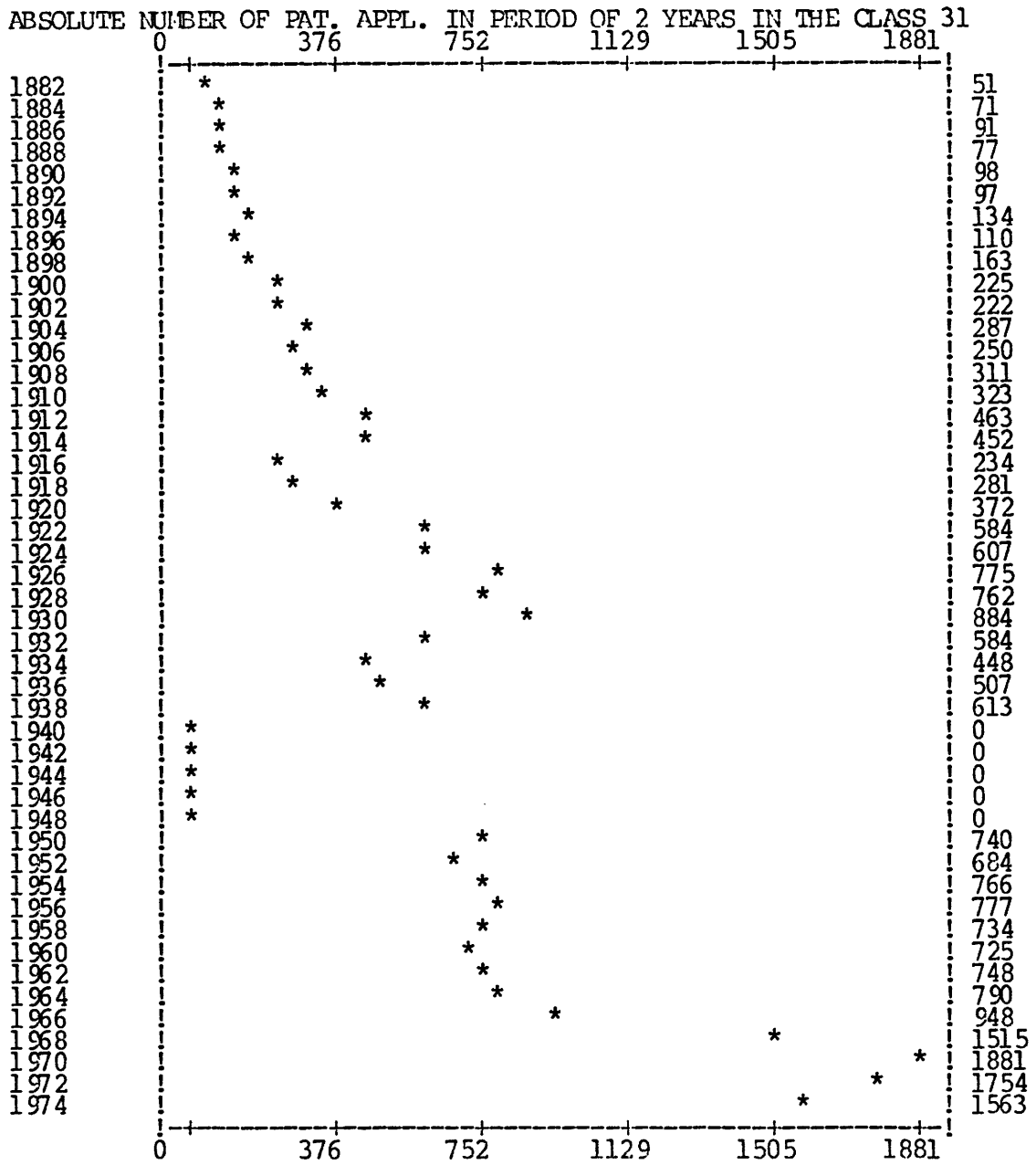

PROPORTION OF TOTAL PAT. APPL. IN 1/1000 IN THE CLASS 31

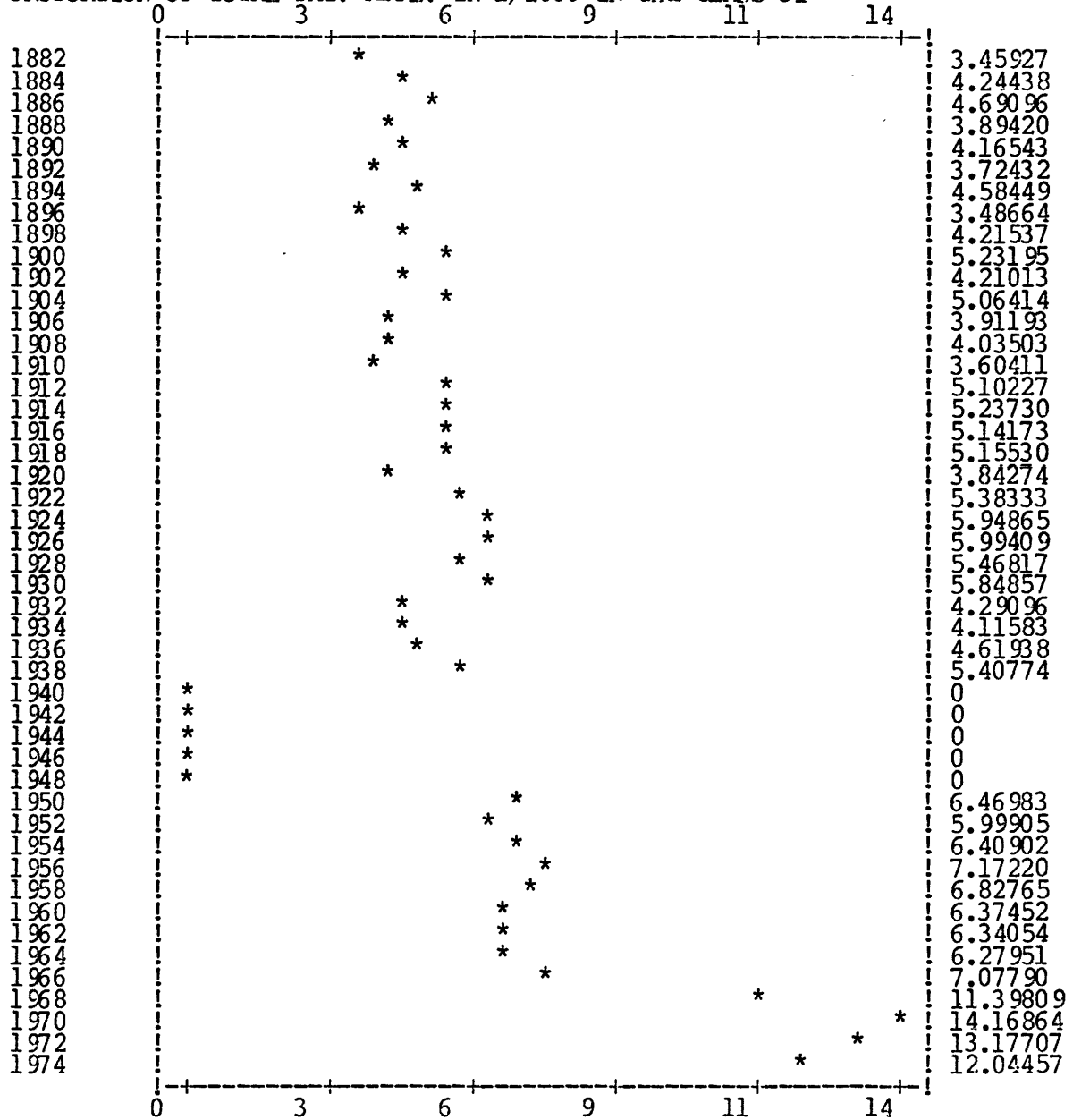

Cl. 32 Glass; mineral and slag wool

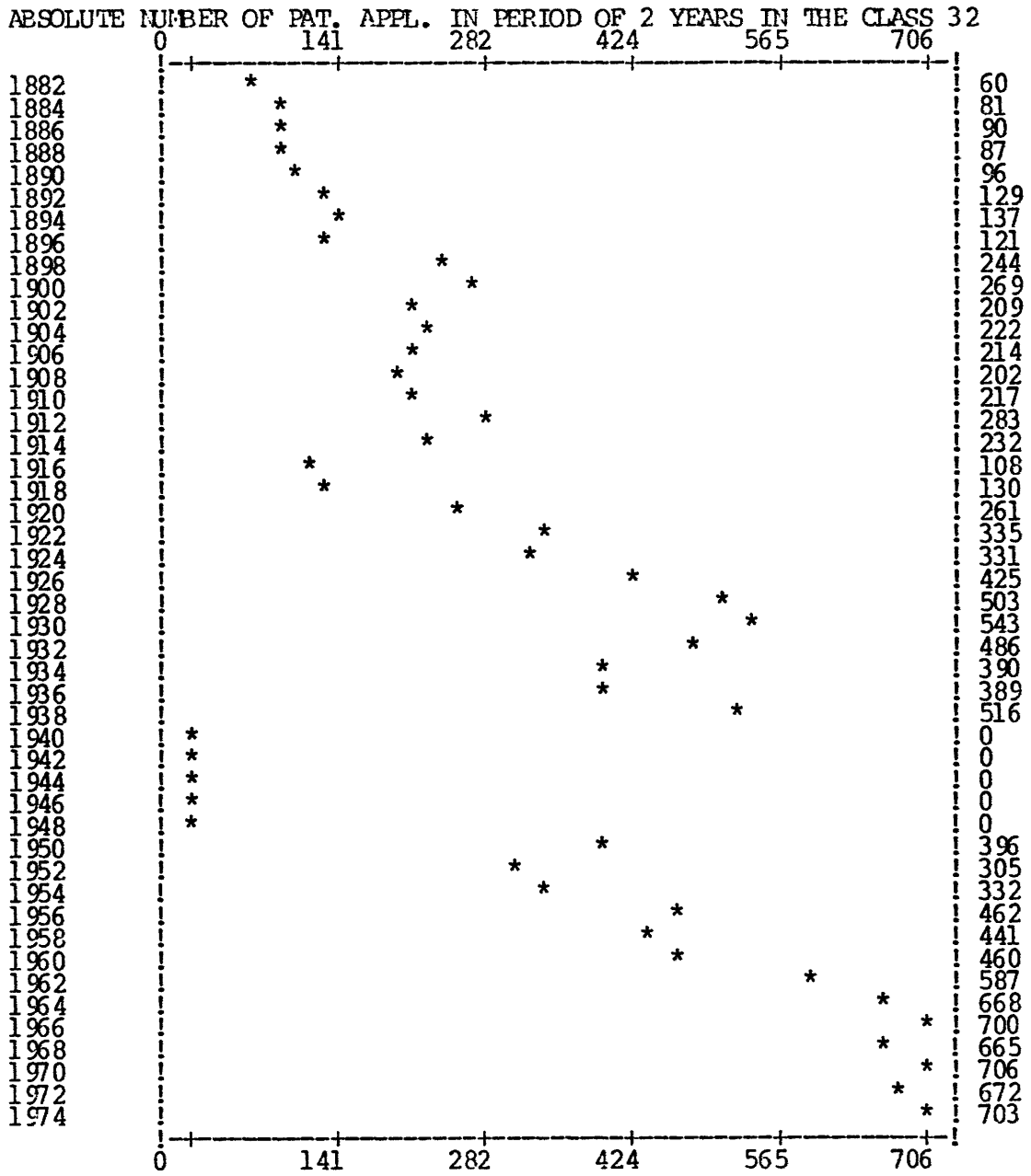

PROPORTION OF TOTAL PAT. APPL. IN 1/1000 IN THE CLASS 32

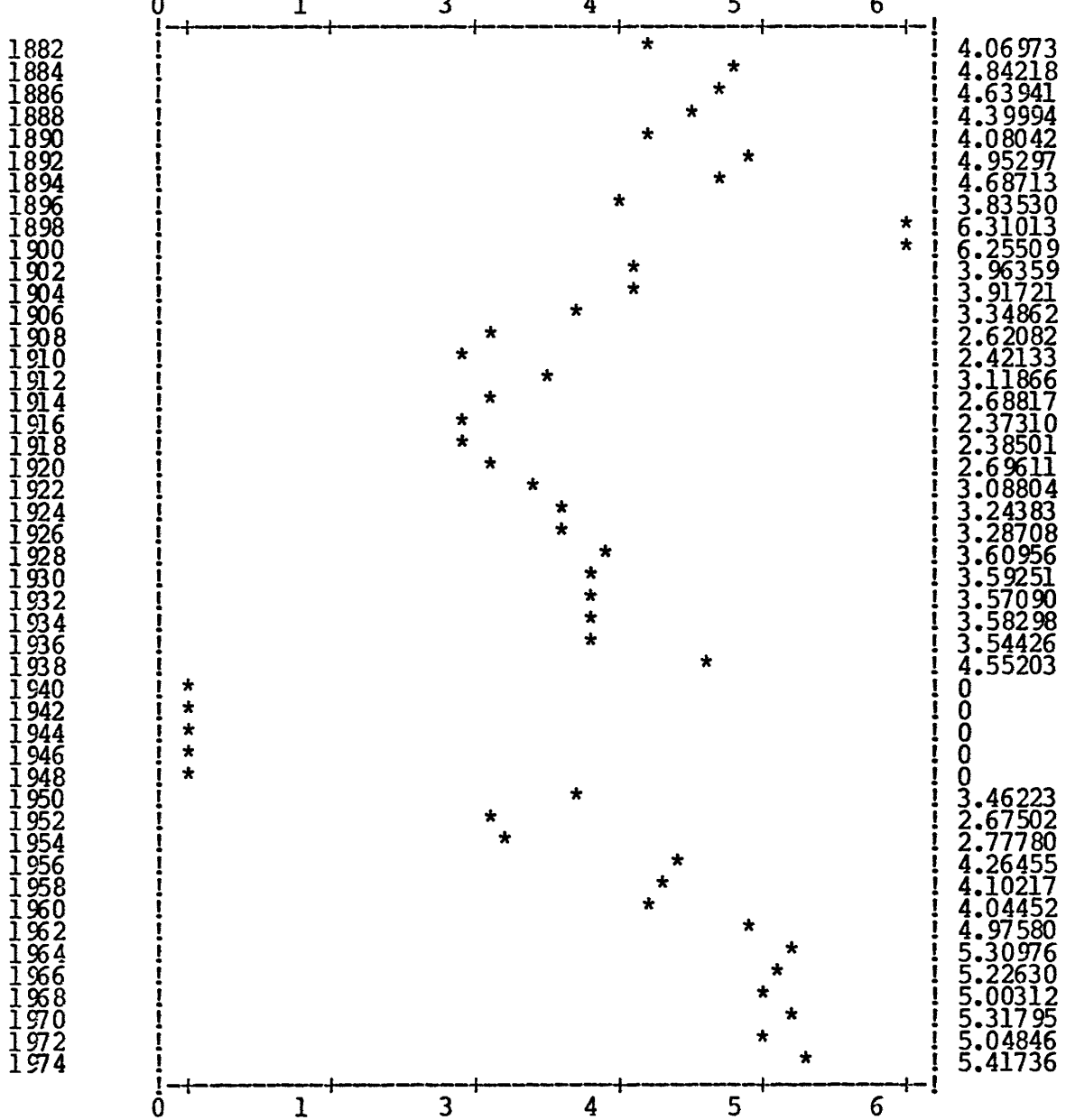

Cl. 33 Hand and travelling articles

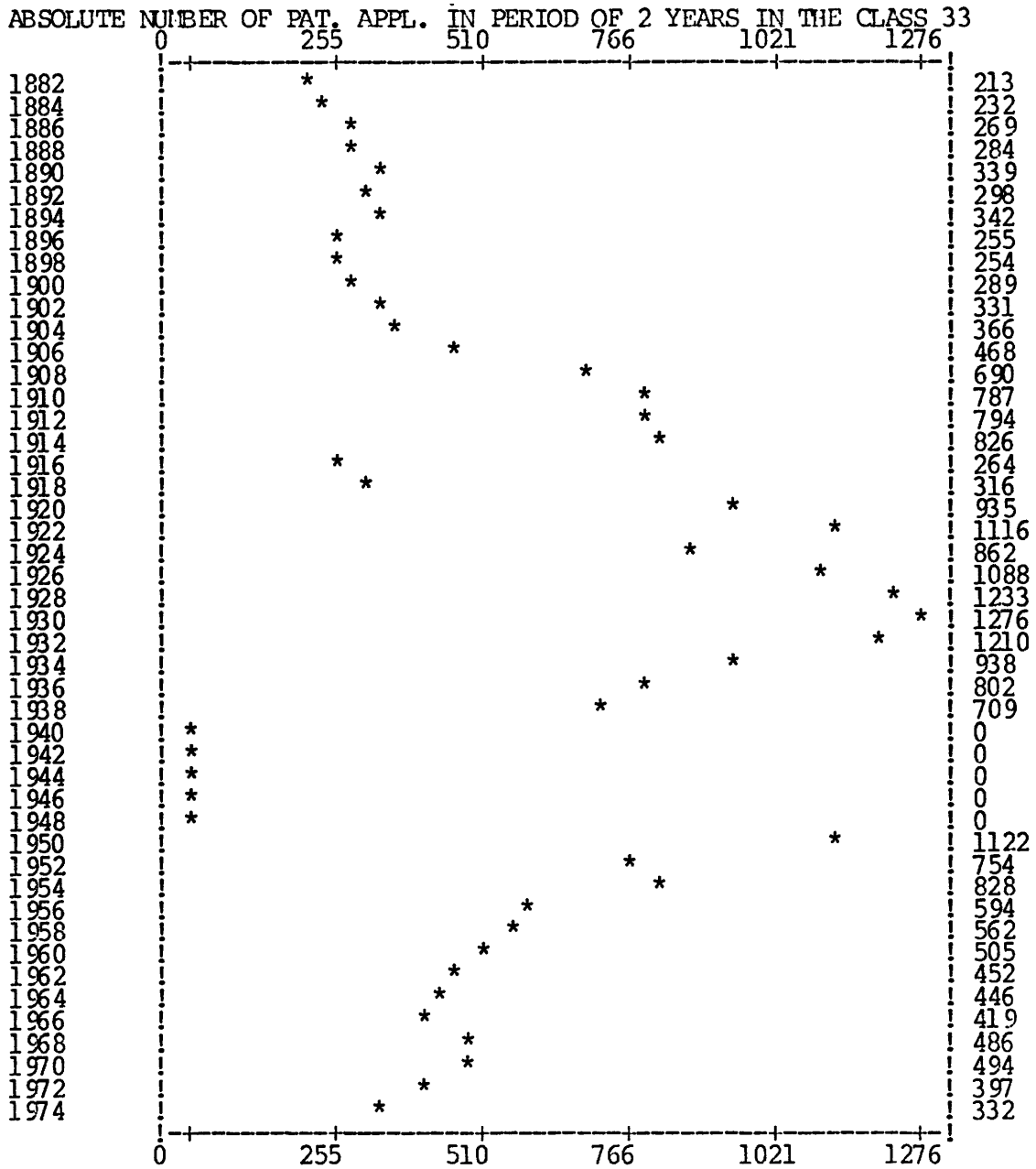

PROPORTION OF TOTAL PAT. APPL. IN 1/1000 IN THE CLASS 33

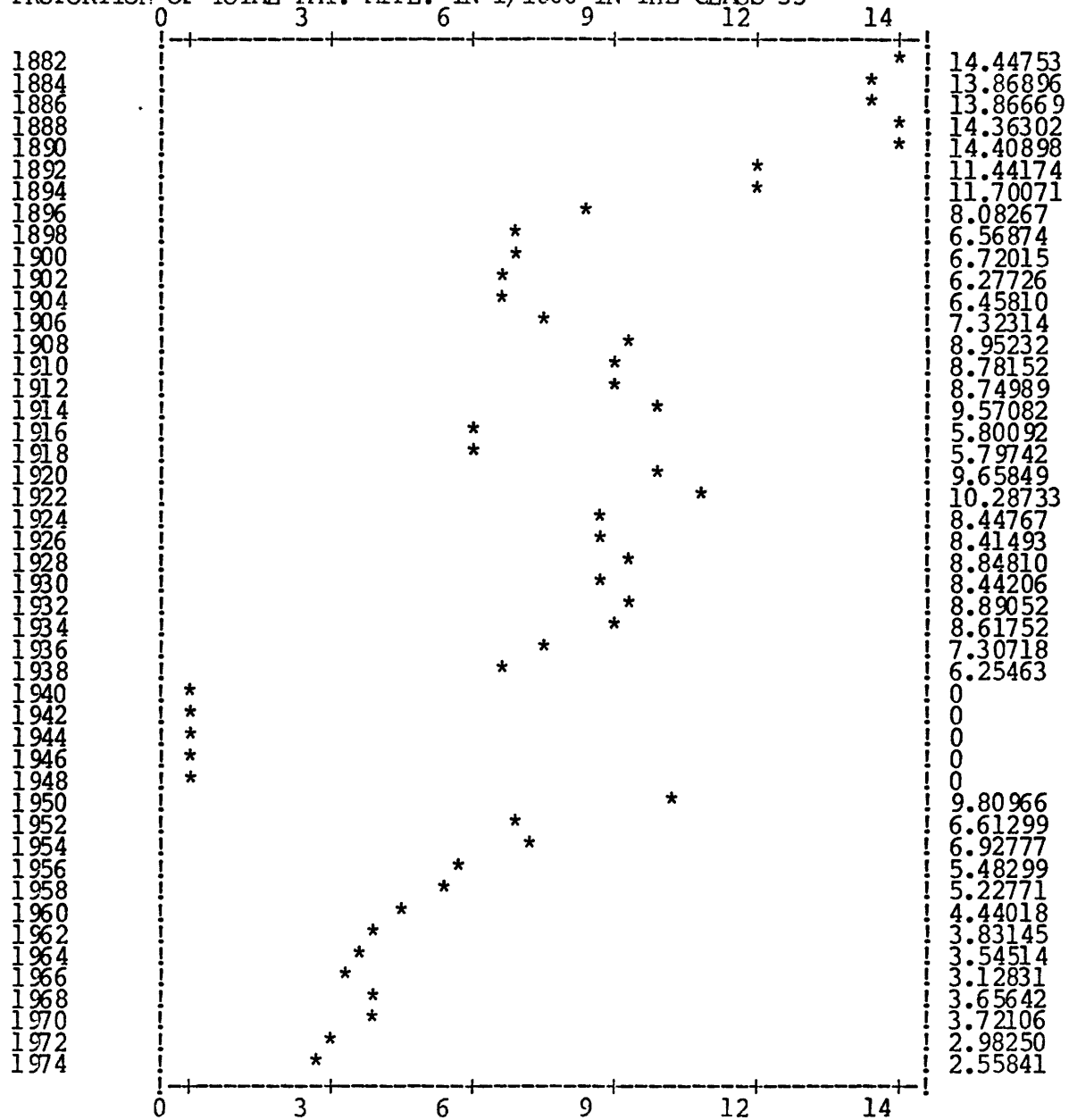



Cl. 34 Furniture; domestic articles or appliances; suction cleaners in general

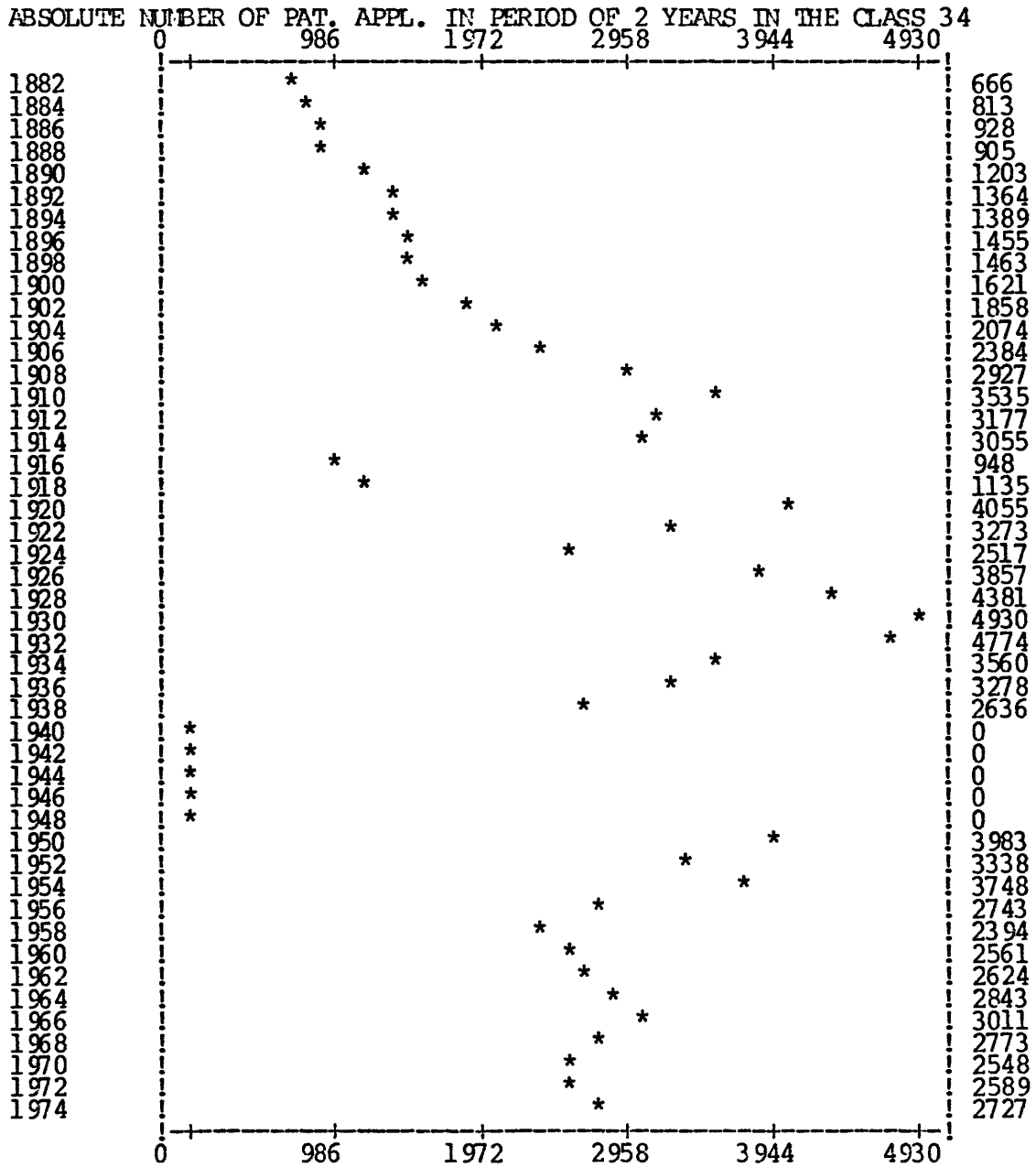

PROPORTION OF TOTAL PAT. APPL. IN 1/1000 IN THE CLASS 34

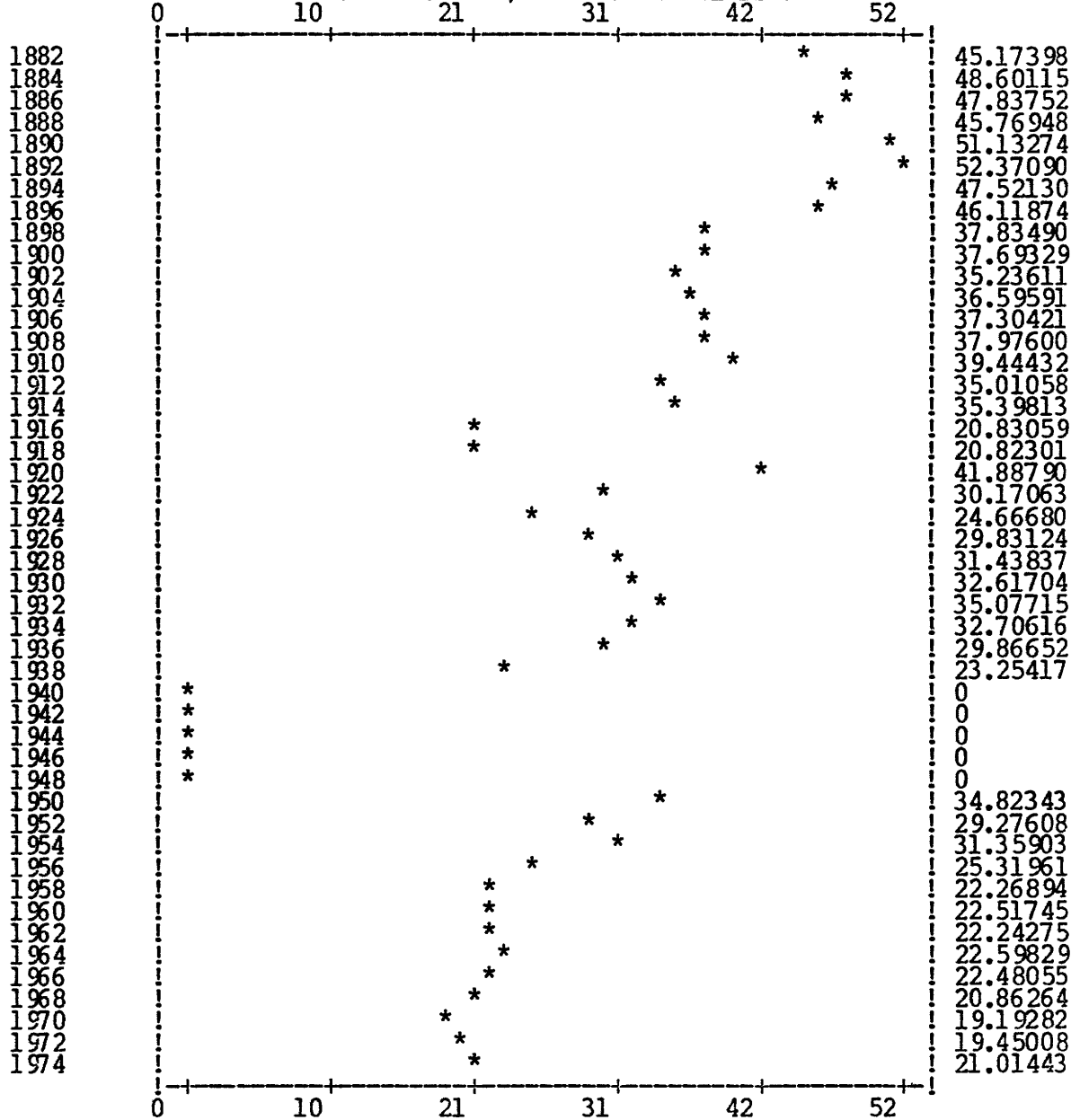

Cl. 35 Lifting gear (lifts, cranes, winches, hoists)

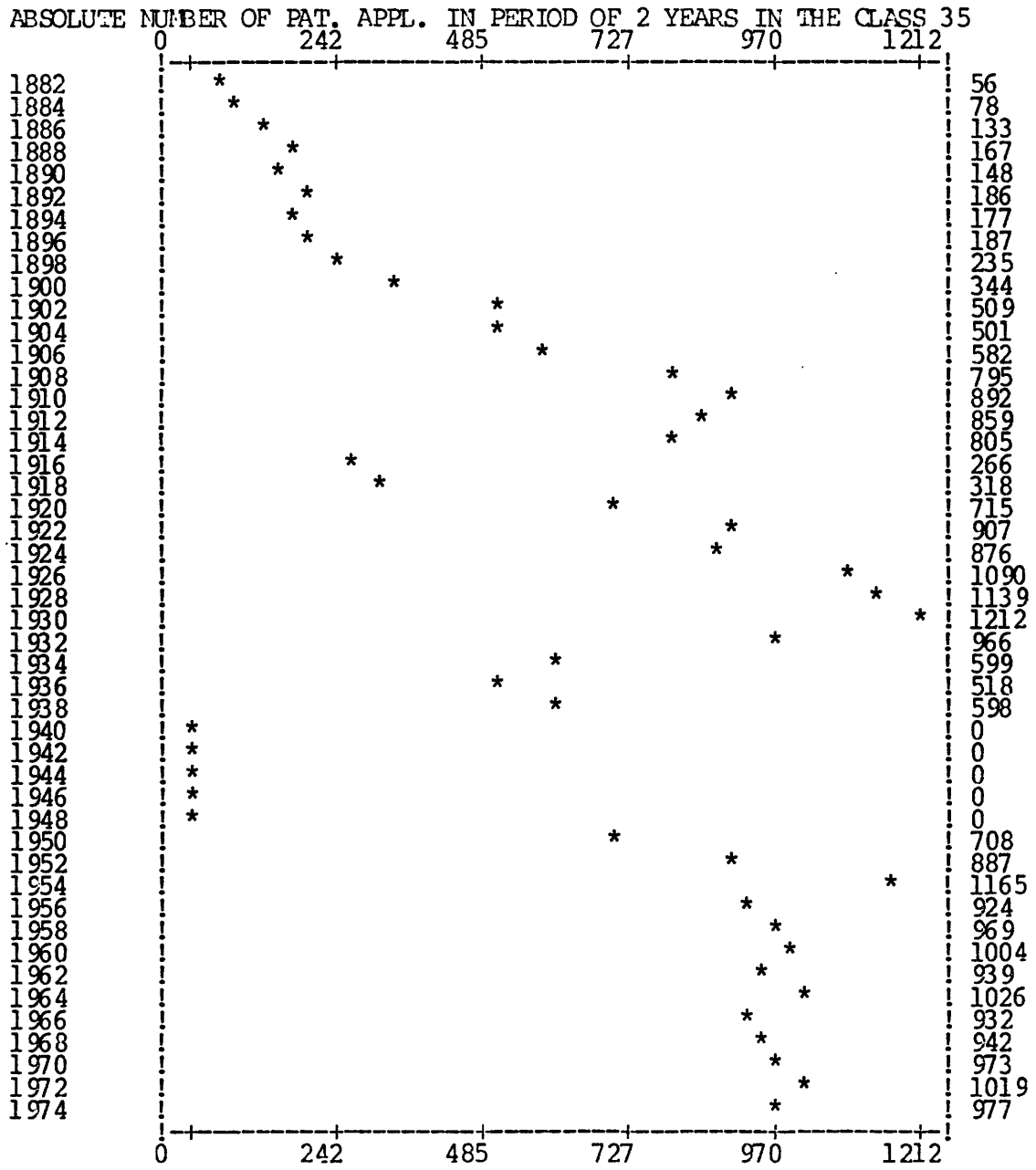

PROPORTION OF TOTAL PAT. APPL. IN 1/1000 IN THE CLASS 35

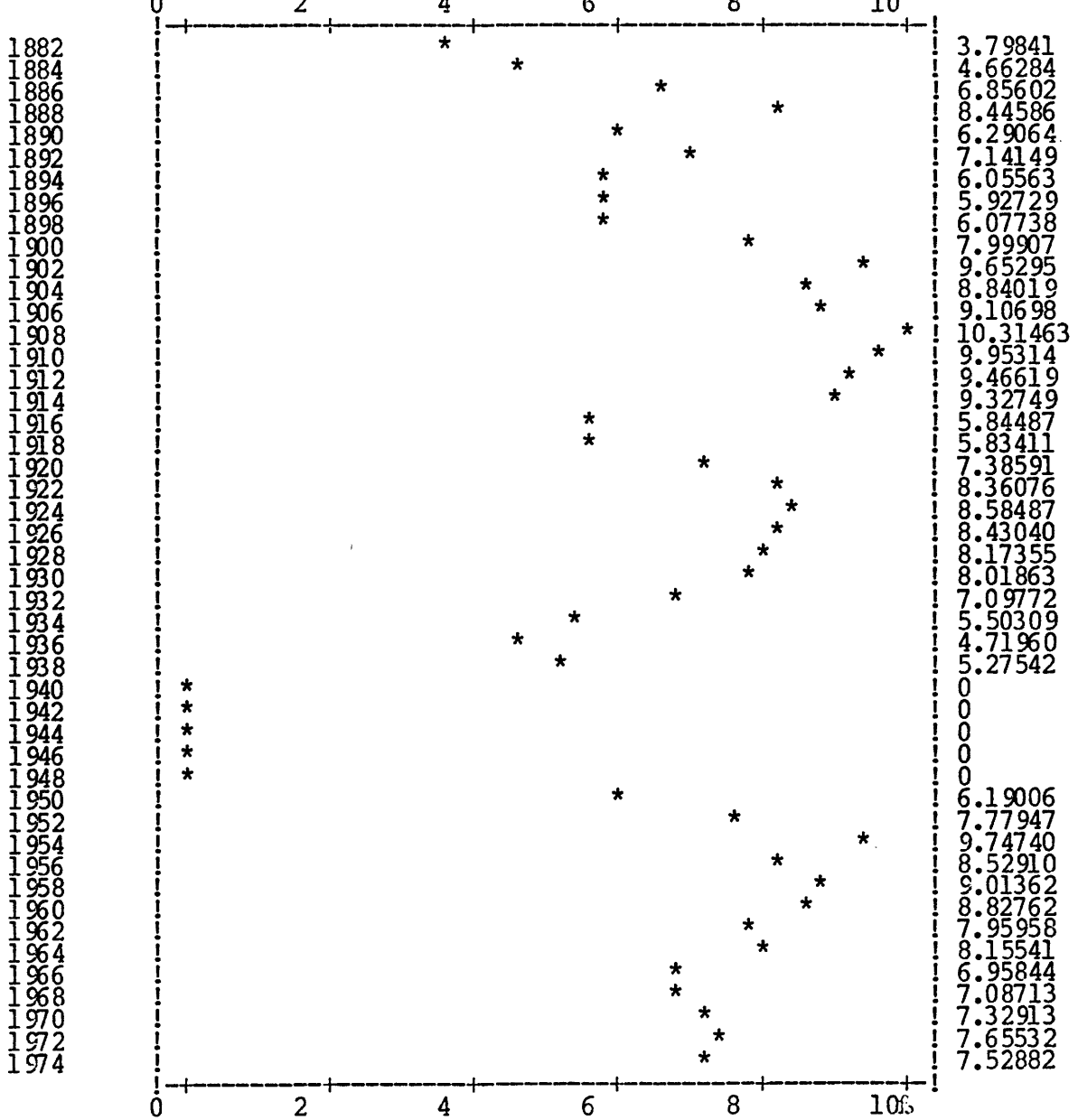

Cl. 36 Heating, ventilation, hot water supply in buildings

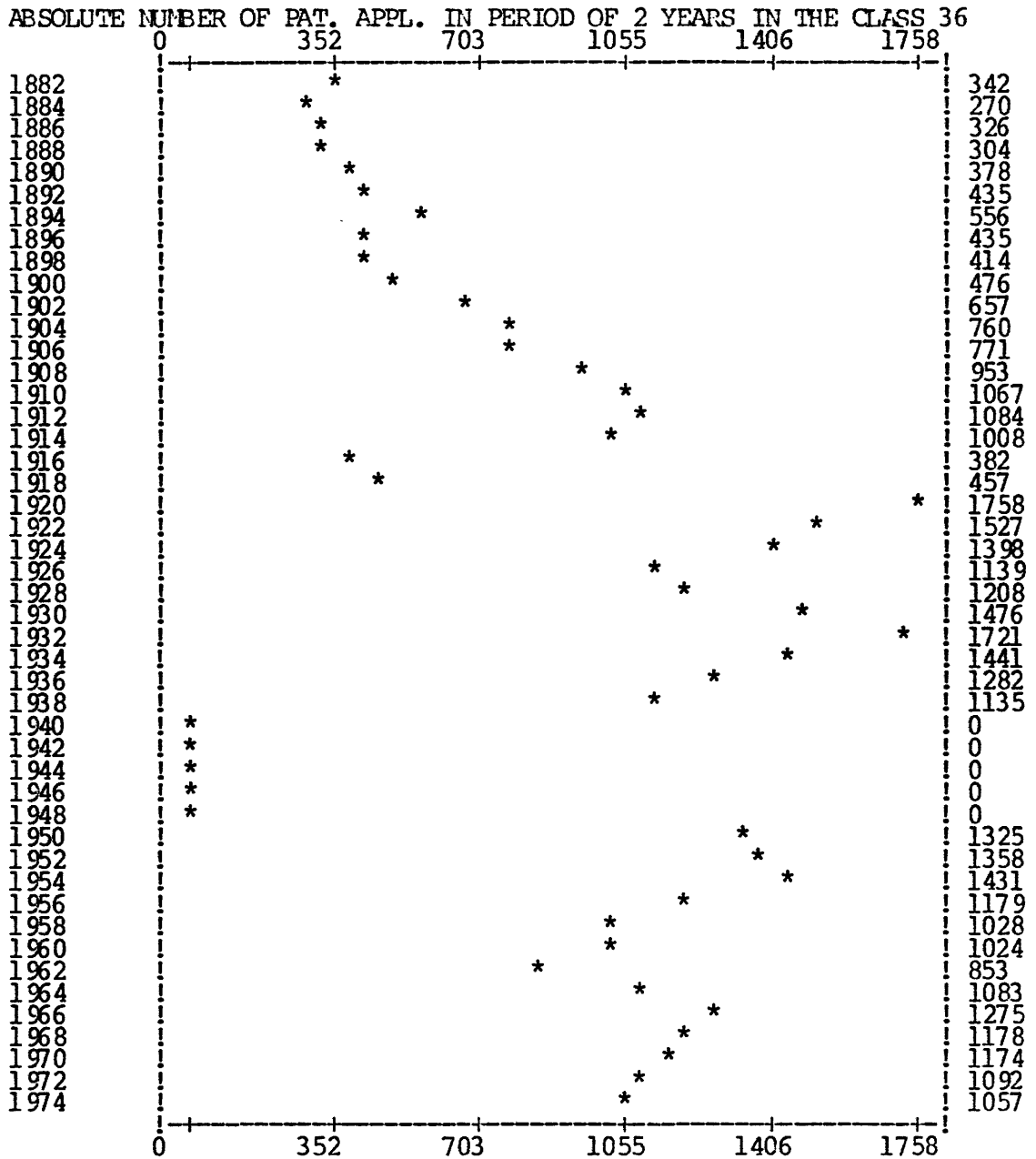

PROPORTION OF TOTAL PAT. APPL. IN 1/1000 IN THE CLASS 36

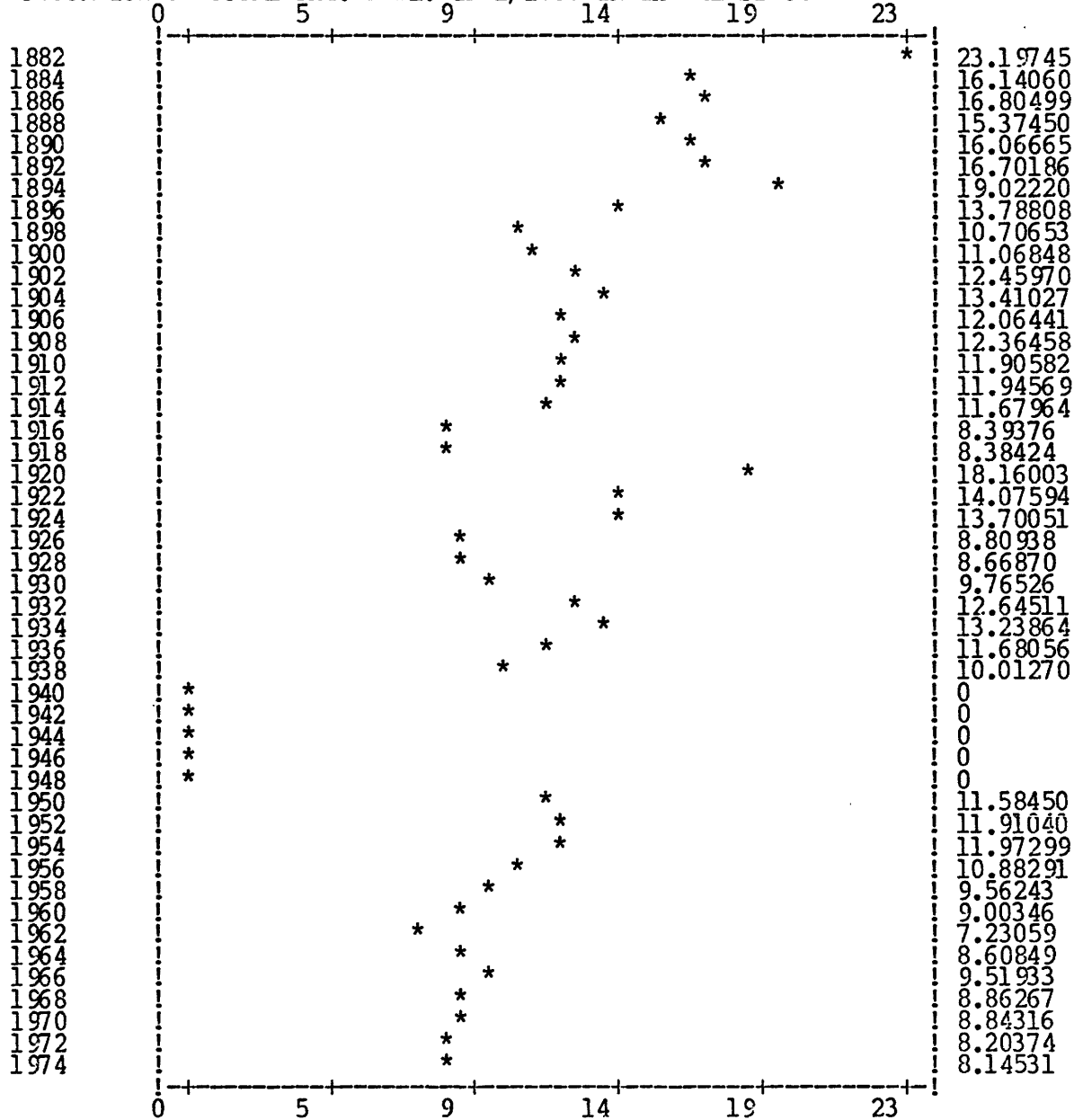

Cl. 37 Building

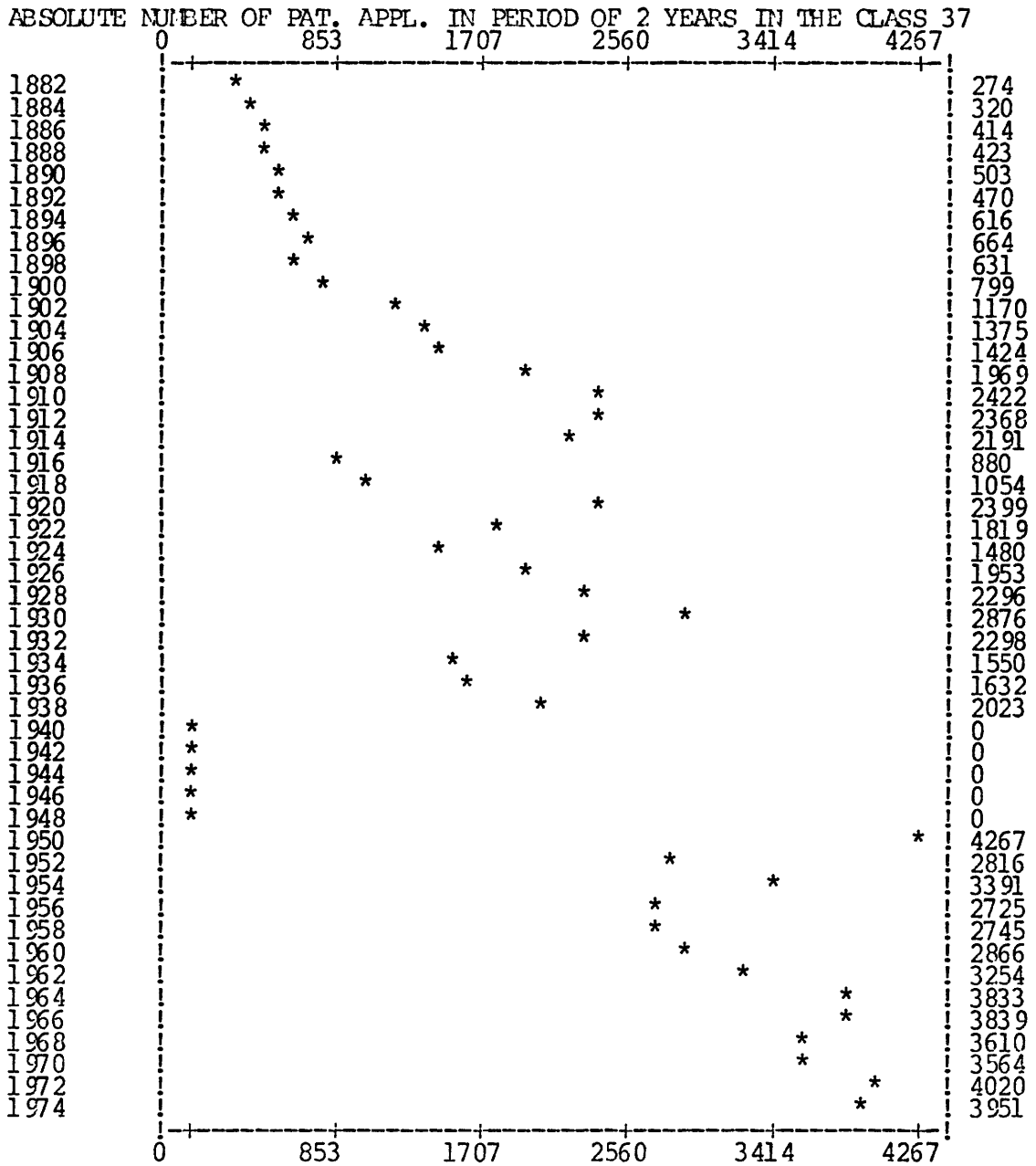

PROF. DR. K. H. KÖNIG, LEITENDE STAATSBÜCHSENER

№ 159.

Zu der Patentschrift

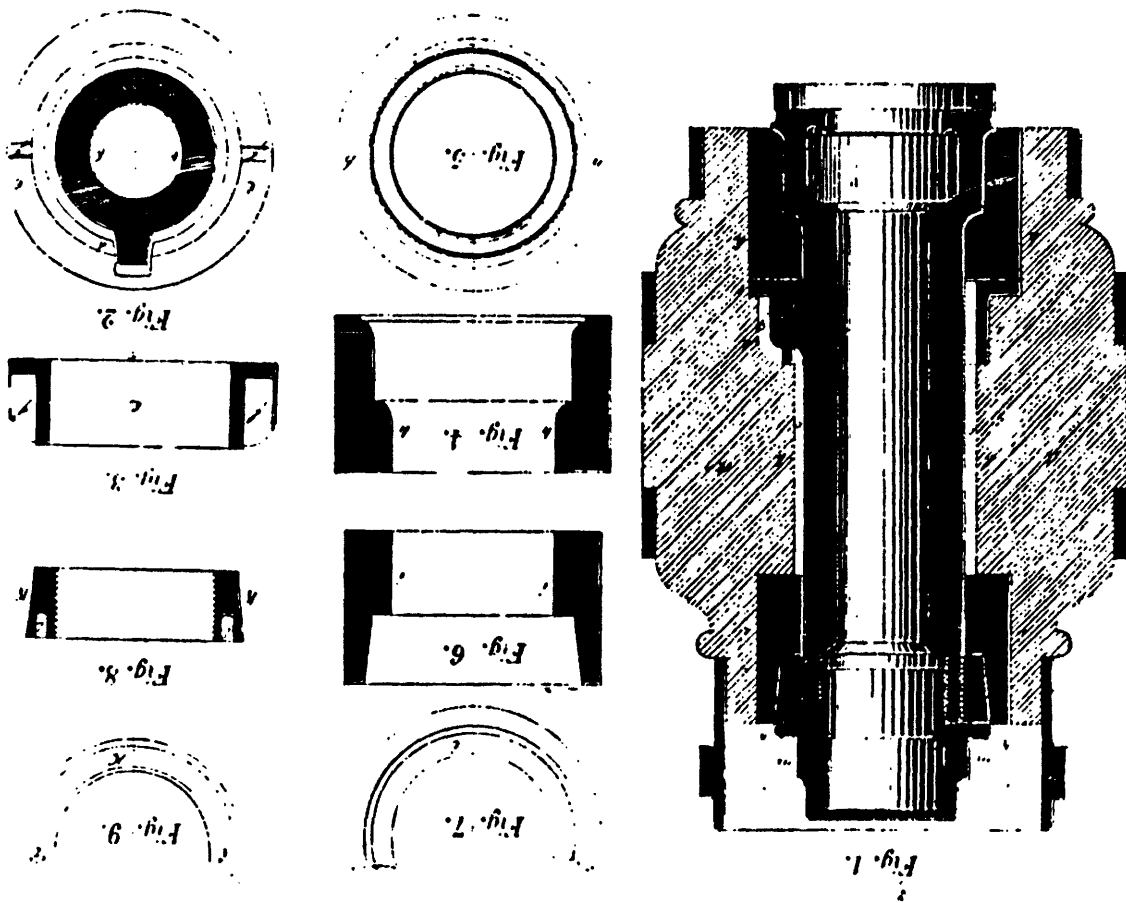

Wagenwaage

DICK & KIRSCHKE, LEITENDE STAATSBÜCHSENER



C. ALBERT BIERLING IN DRESDEN.

Verbessertes Fafspund mit Abziehhahn für Lagerfässer und Gährbottiche.

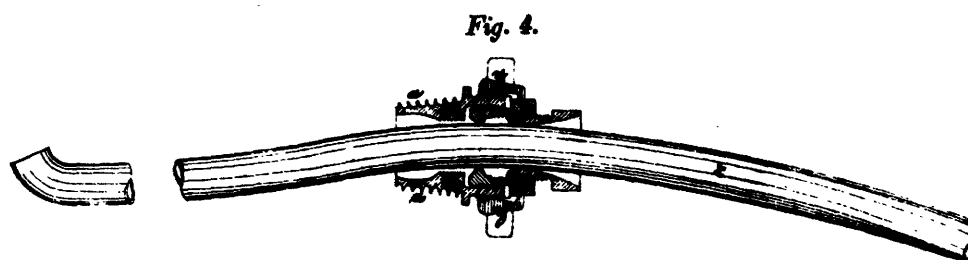
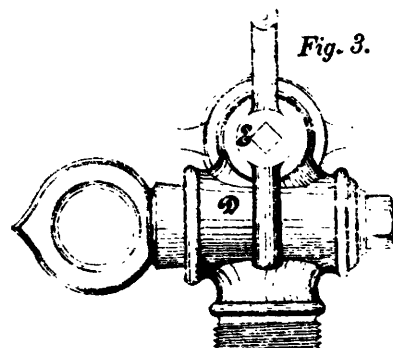
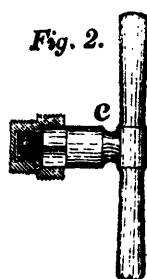
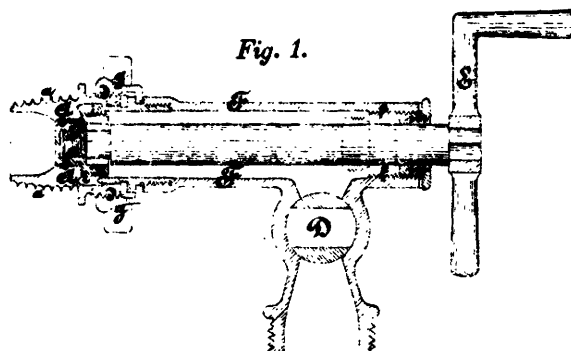

Zu der Patentschrift

№ 145.

PHOTOGR. DRUCK DER KÖNIGL. PREUSS. STAATSDRUCKEREI.

PROPORTION OF TOTAL PAT. APPL. IN 1/1000 IN THE CLASS 37

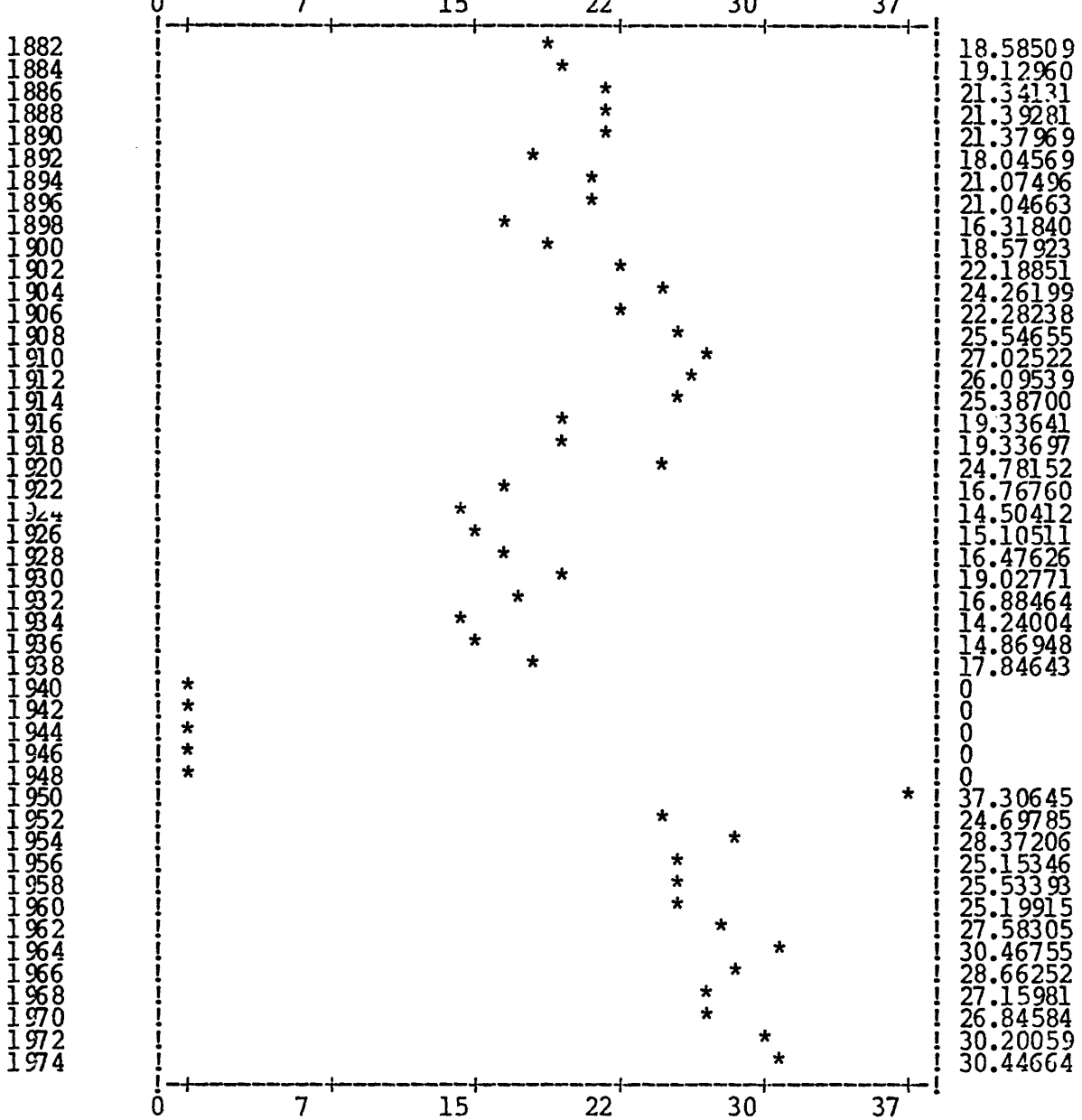

Cl. 38 Wood working by mechanical and chemical means

ABSOLUTE NUMBER OF PAT. APPL. IN PERIOD OF 2 YEARS IN THE CLASS 38

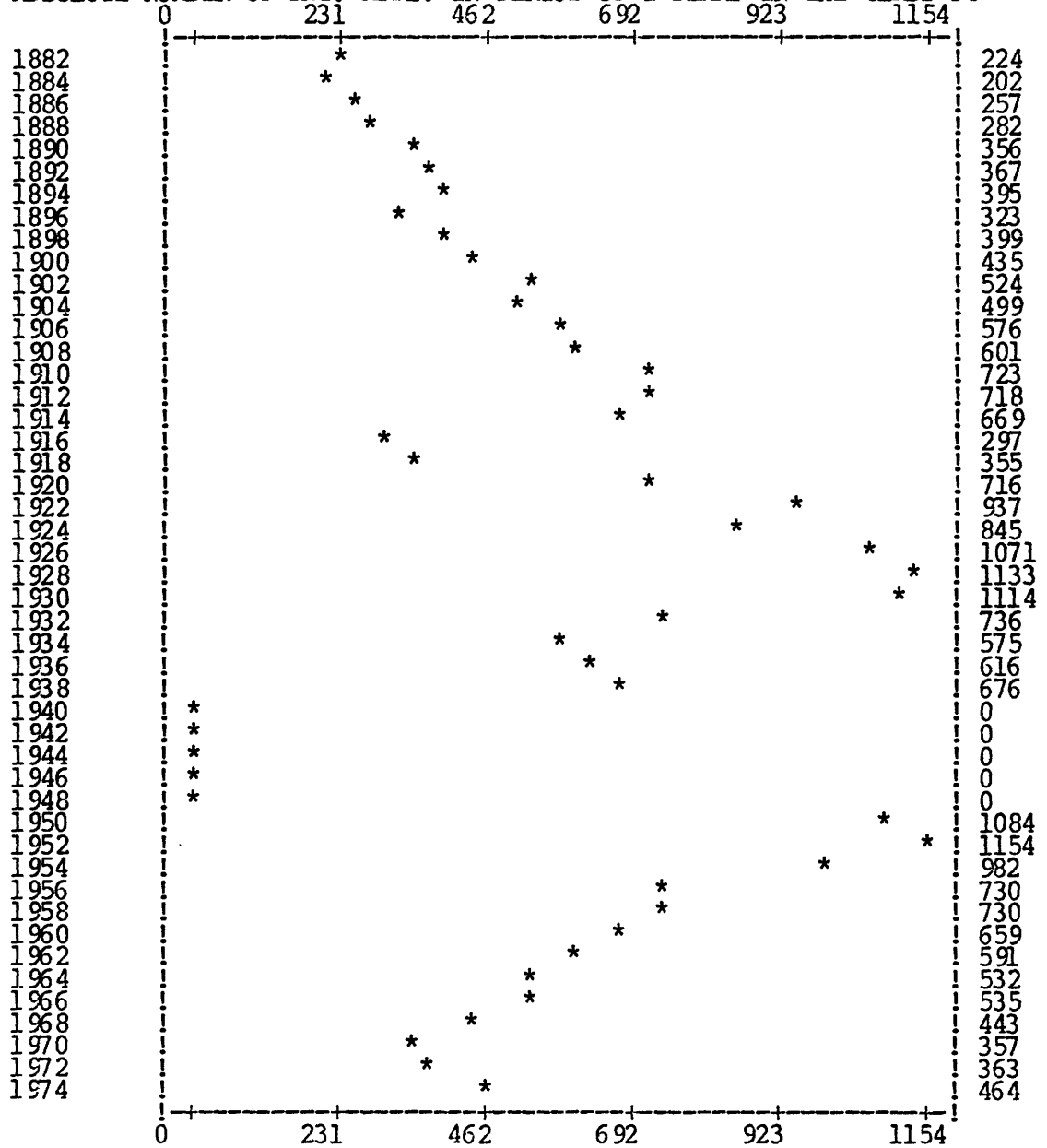

PROPORTION OF TOTAL PAT. APPL. IN 1/1000 IN THE CLASS 38

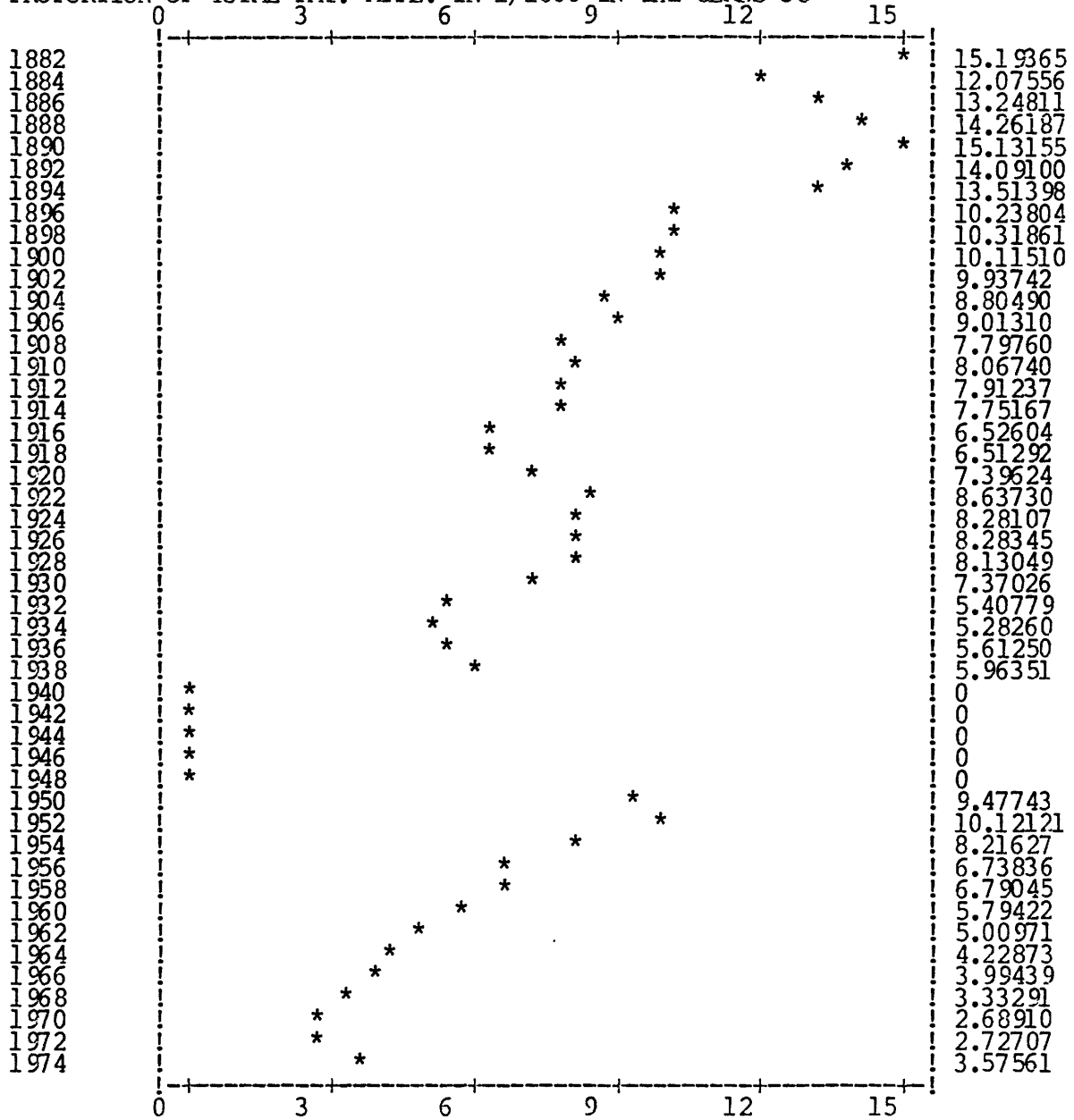

Cl. 39 Working of plastic masses, rubber and horny materials not otherwise provided for; products of polycondensation, polyaddition and polymerization

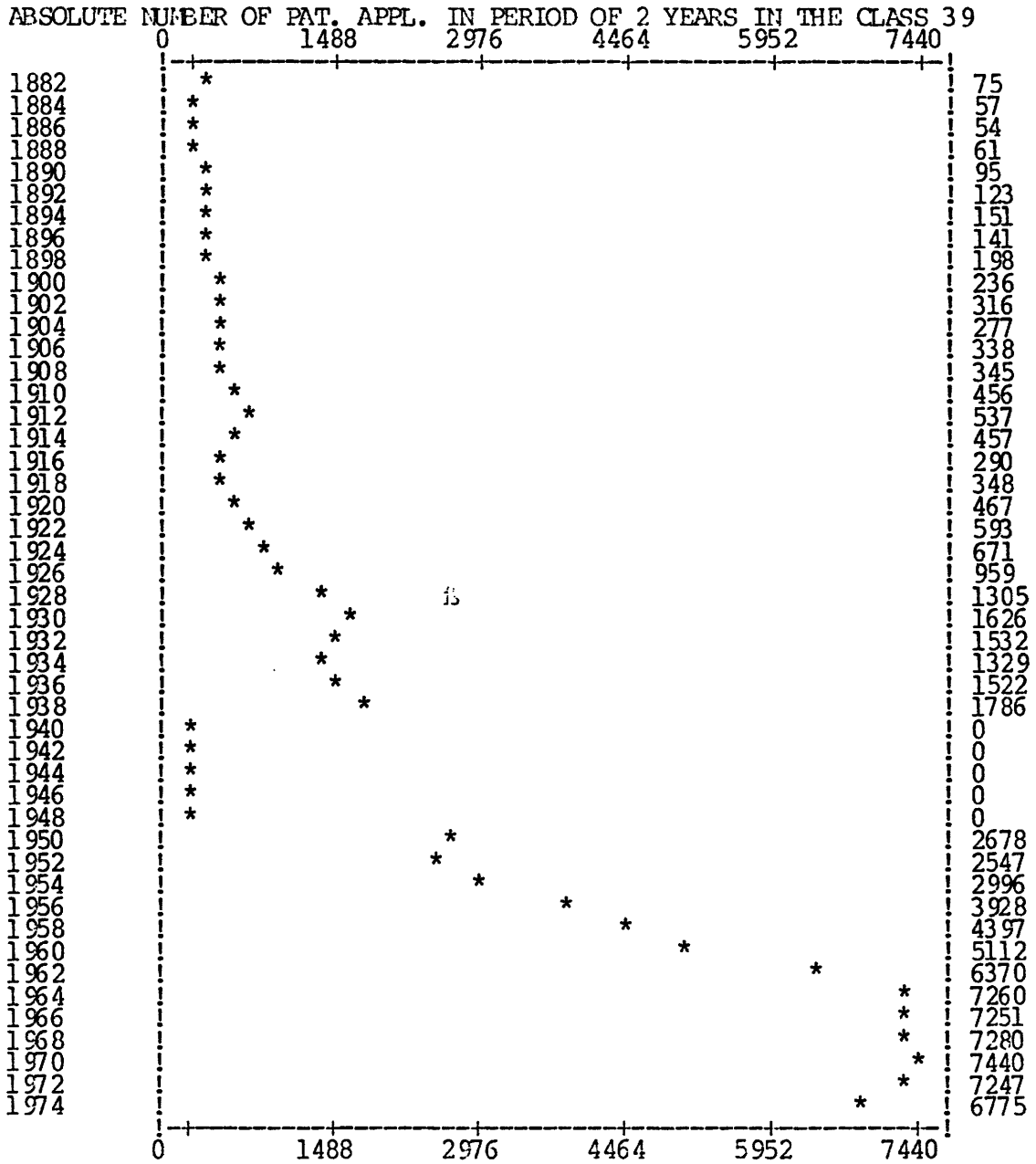

PROPORTION OF TOTAL PAT. APPL. IN 1/1000 IN THE CLASS 39

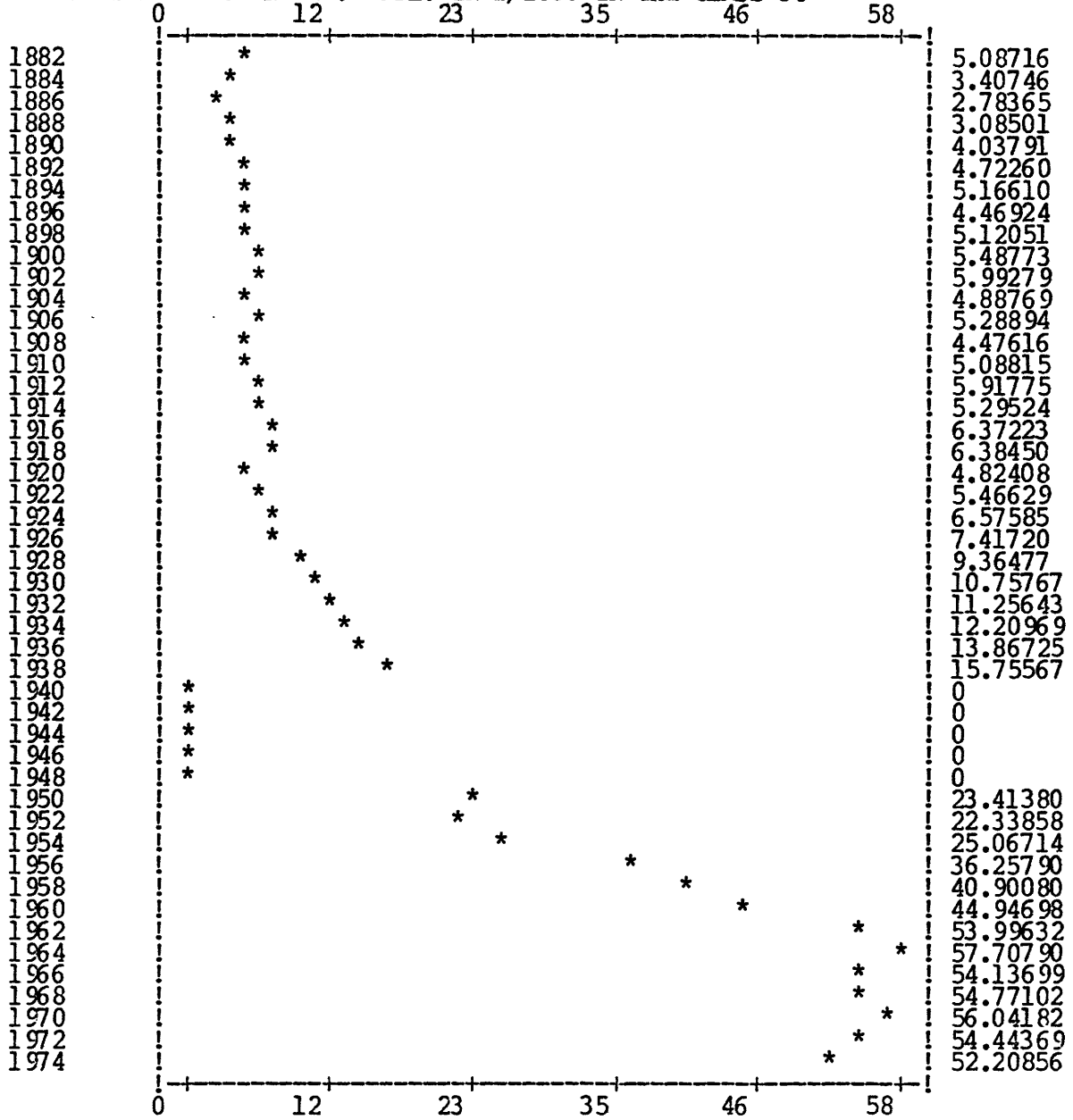

C1. 40 Metallurgy other than of iron; alloys including ferrous alloys

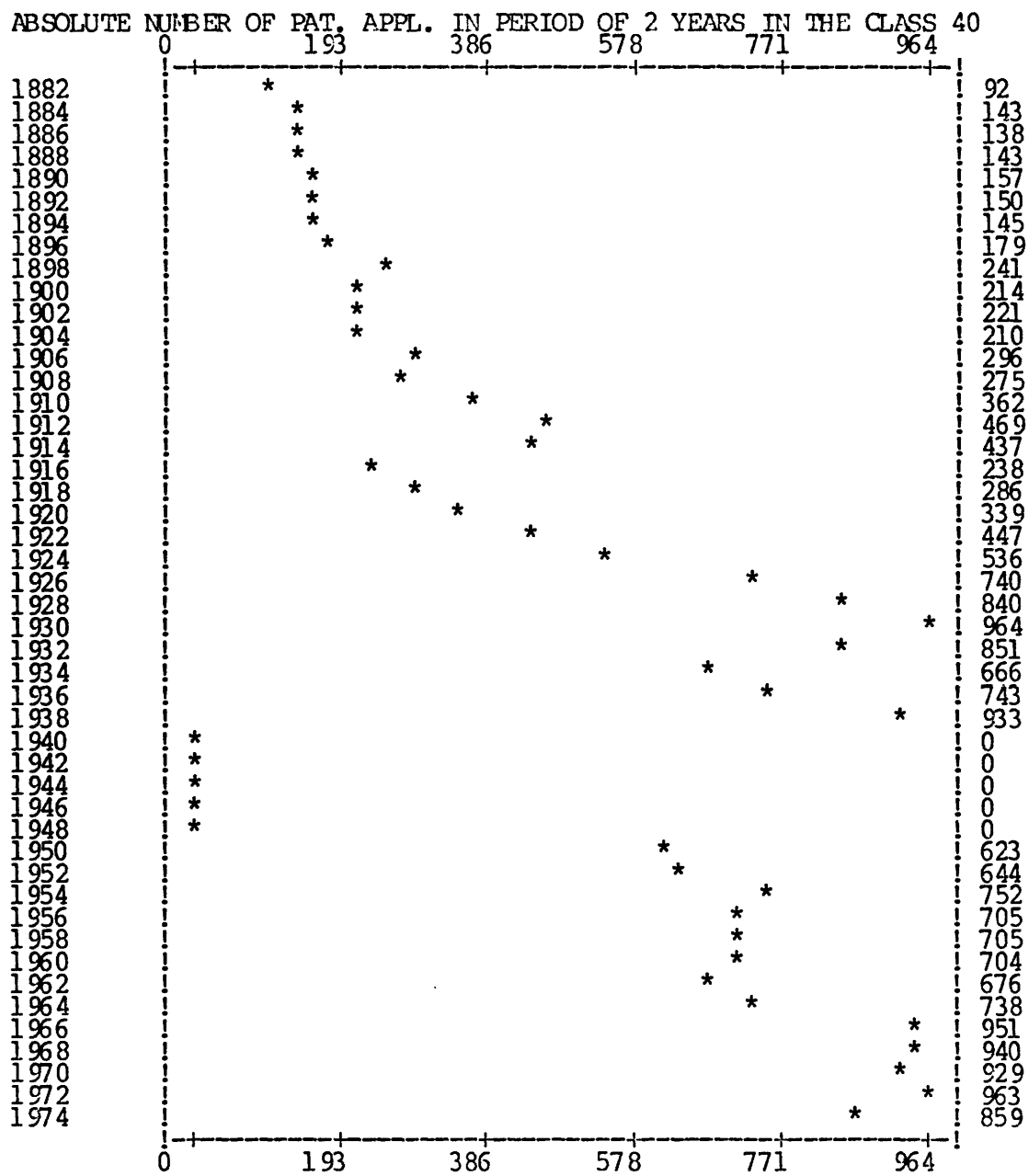

PROPORTION OF TOTAL PAT. APPL. IN 1/1000 IN THE CLASS 40

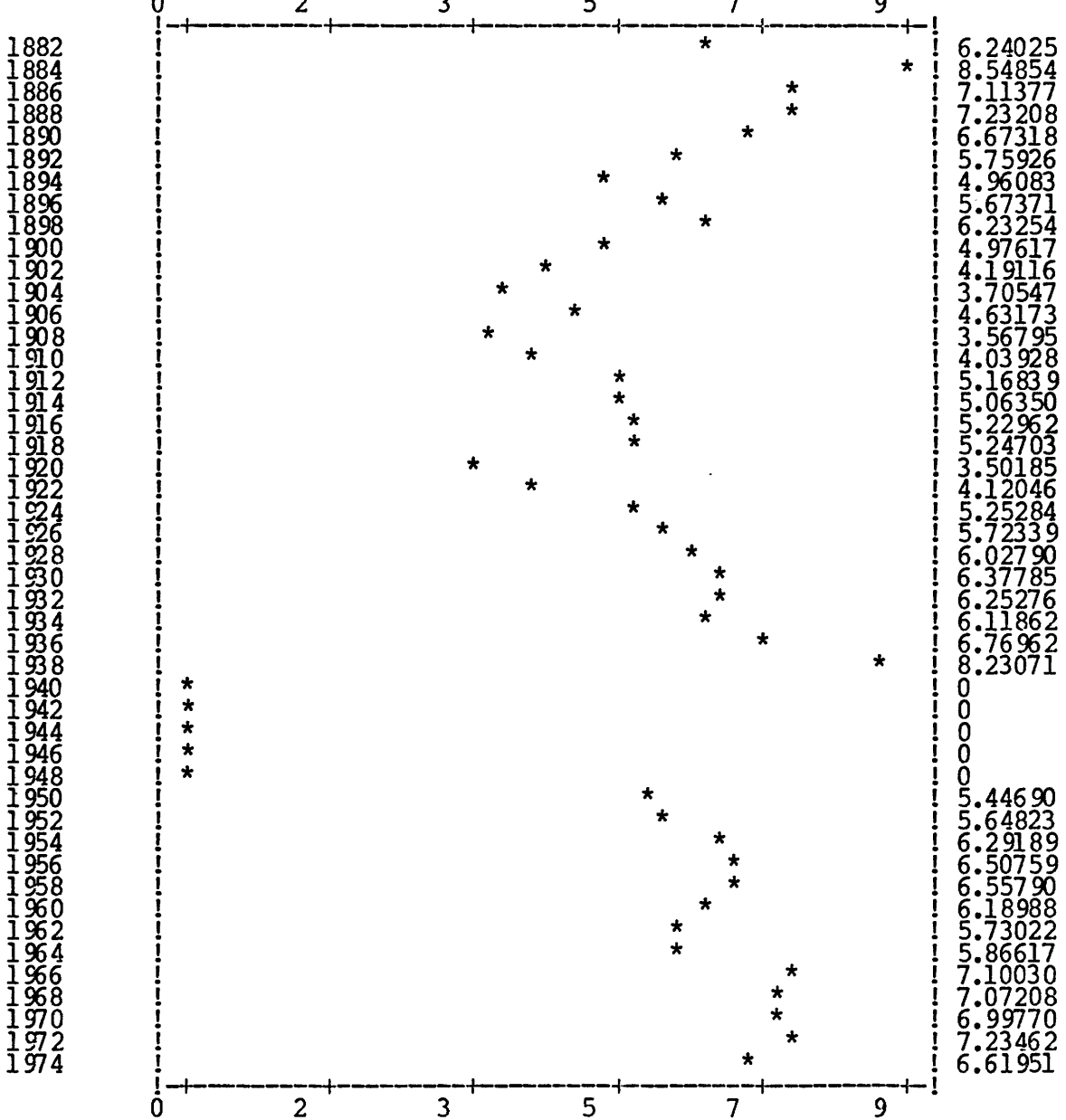



Cl. 41 Headwear; felts

ABSOLUTE NUMBER OF PAT. APPL. IN PERIOD OF 2 YEARS IN THE CLASS 41

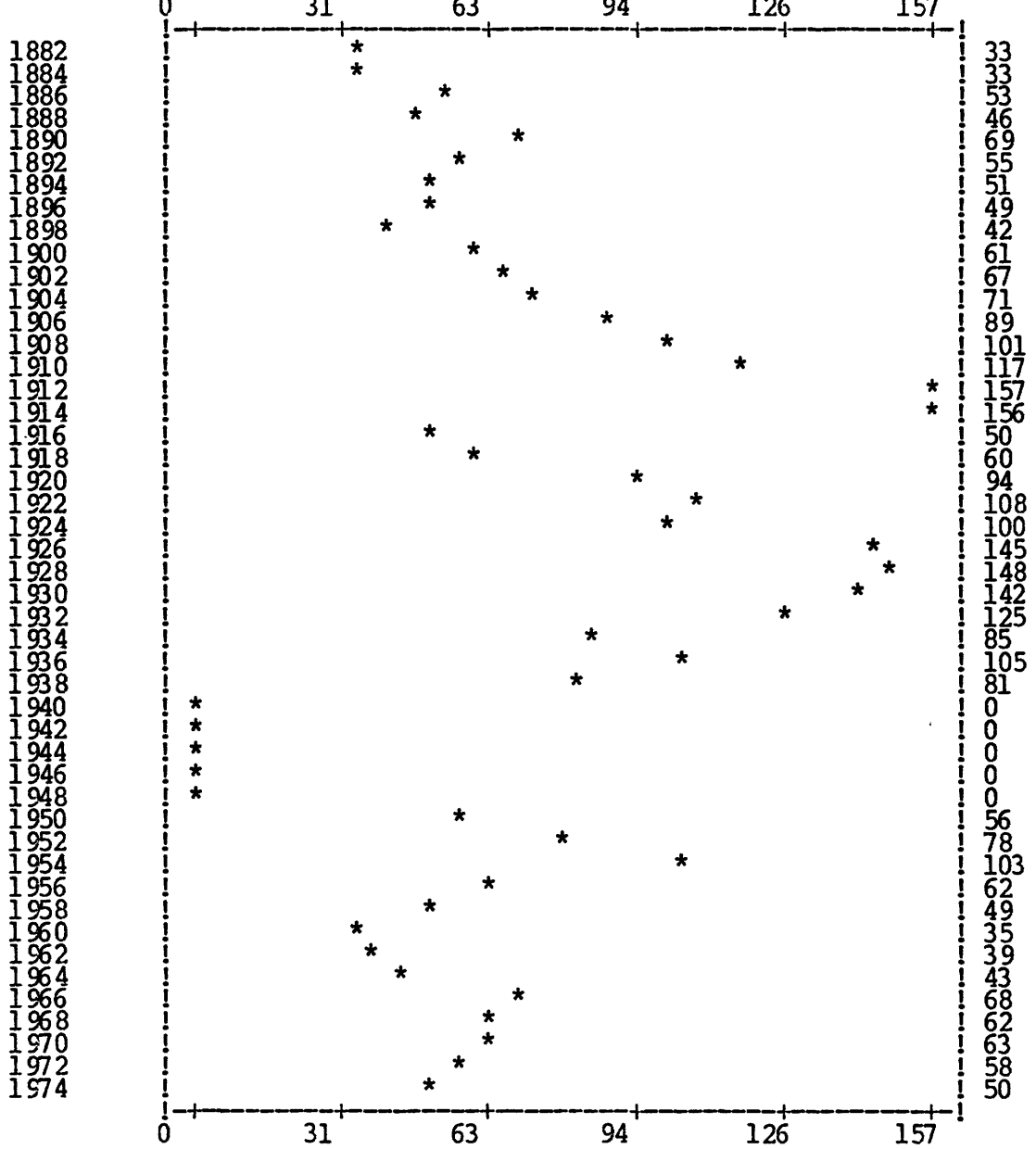

PROPORTION OF TOTAL PAT. APPL. IN 1/1000 IN THE CLASS 41

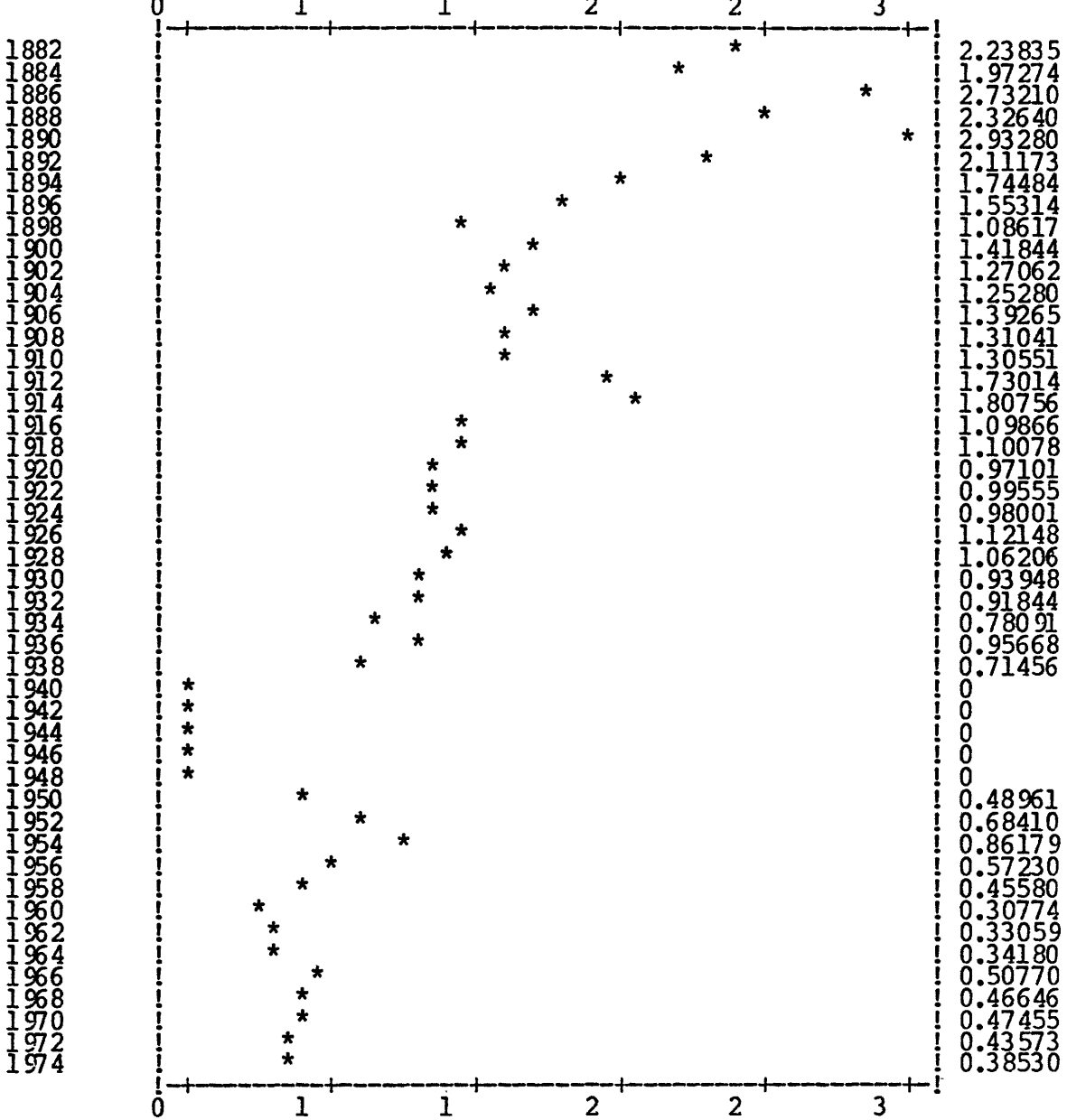

Cl. 42 Instruments

ABSOLUTE NUMBER OF PAT. APPL. IN PERIOD OF 2 YEARS IN THE CLASS 42

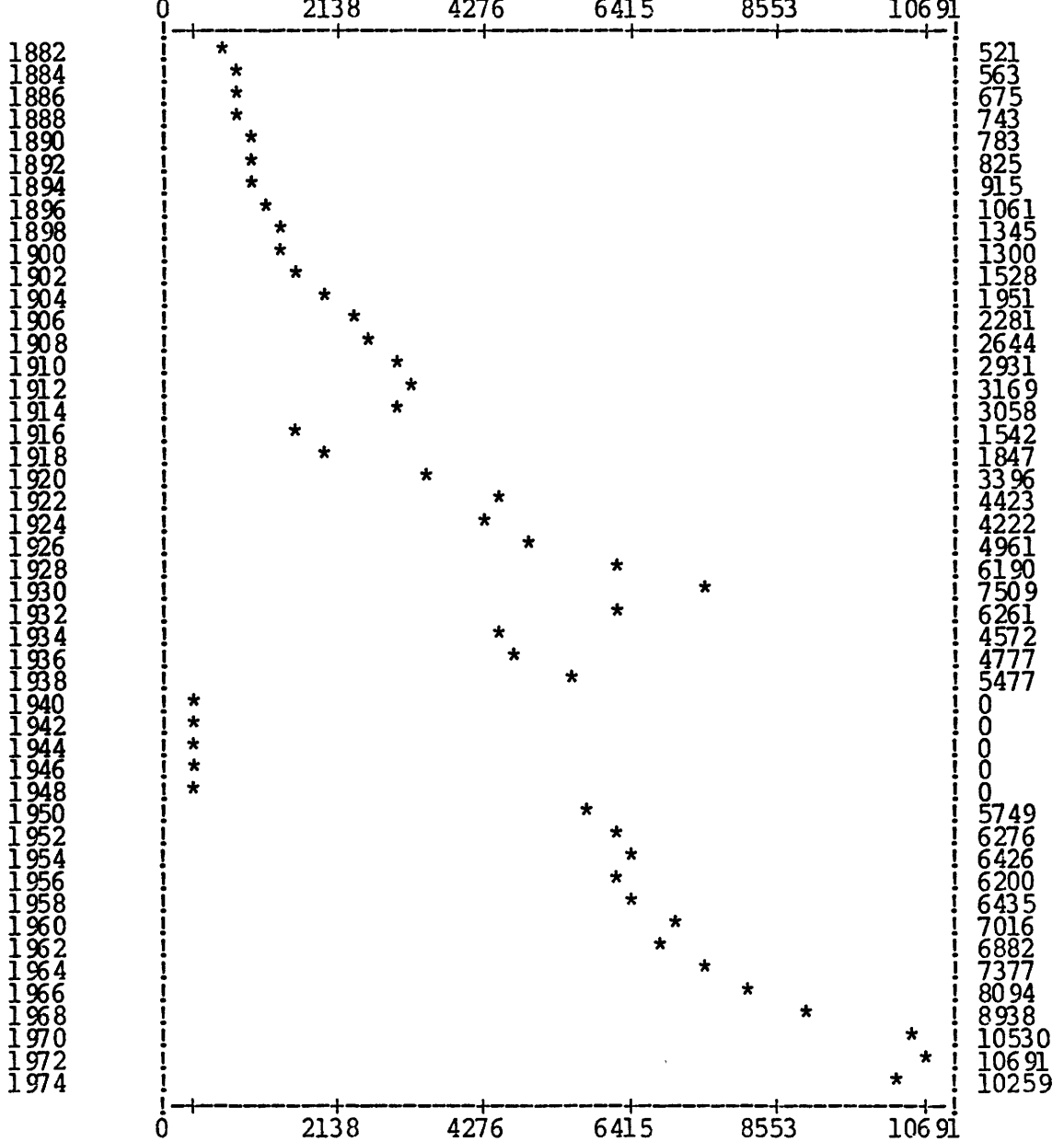

PROPORTION OF TOTAL PAT. APPL. IN 1/1000 IN THE CLASS 42

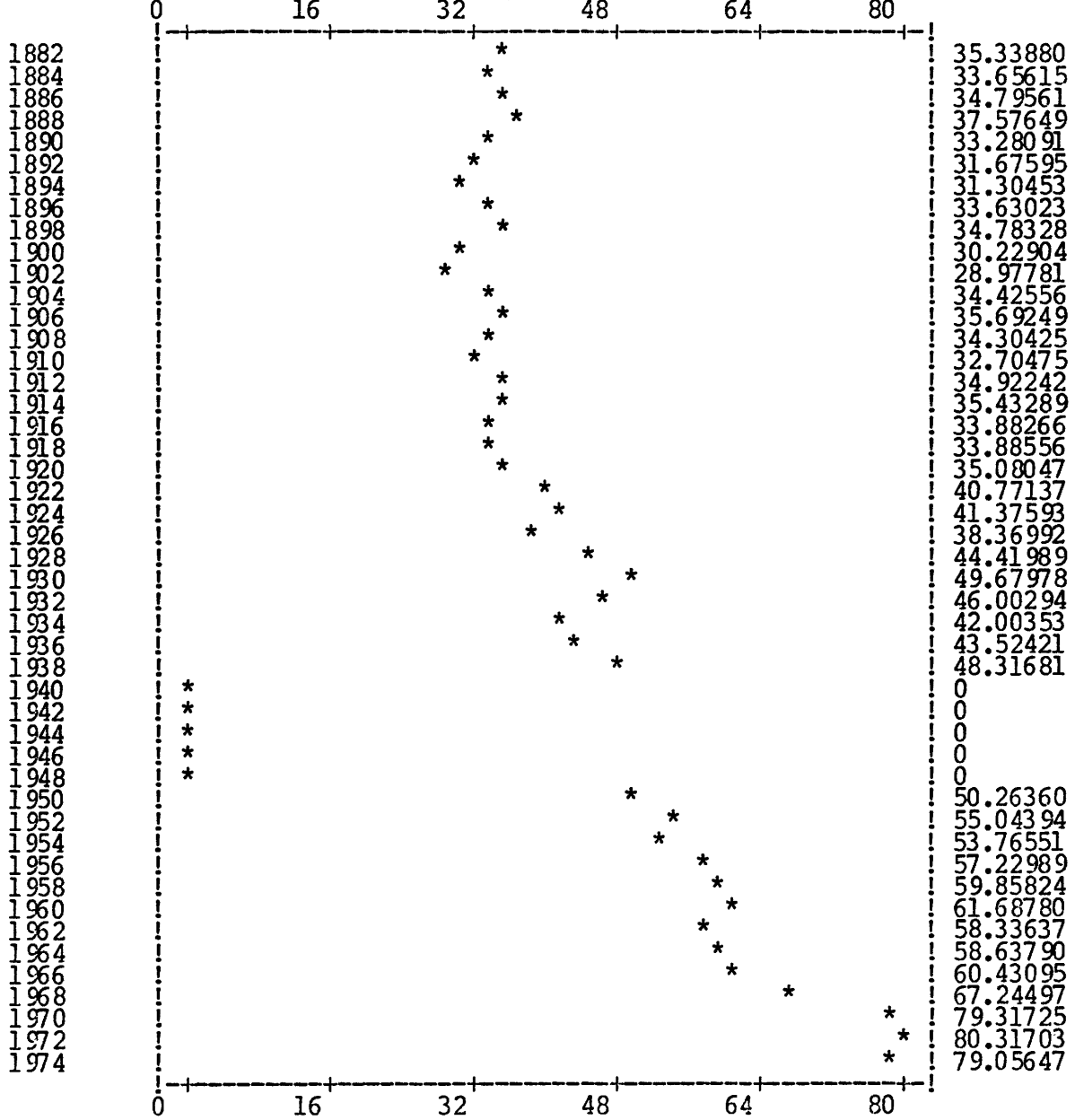

Cl. 43 Checking devices, cash machines and post sorting machines

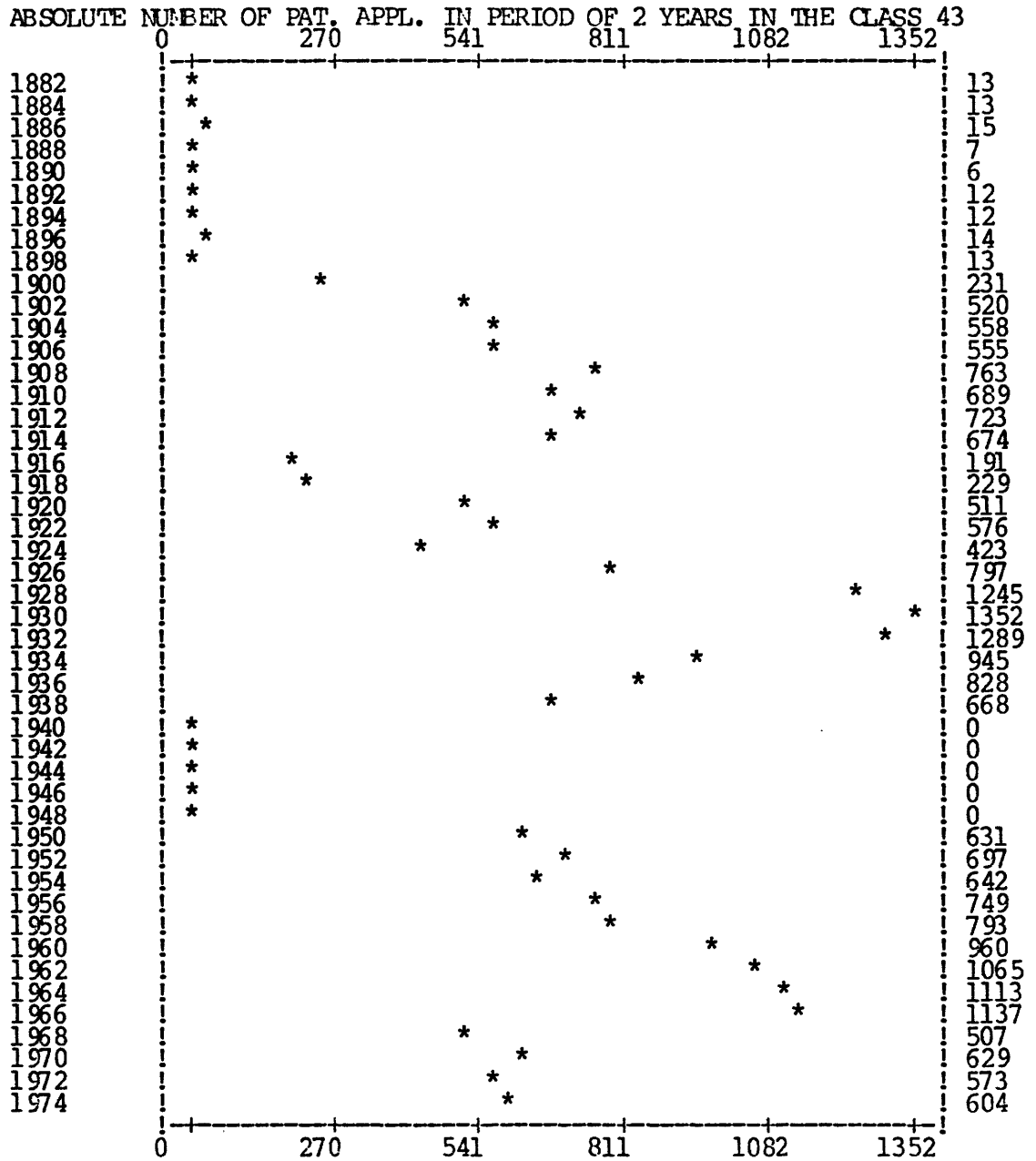

PROPORTION OF TOTAL PAT. APPL. IN 1/1000 IN THE CLASS 43

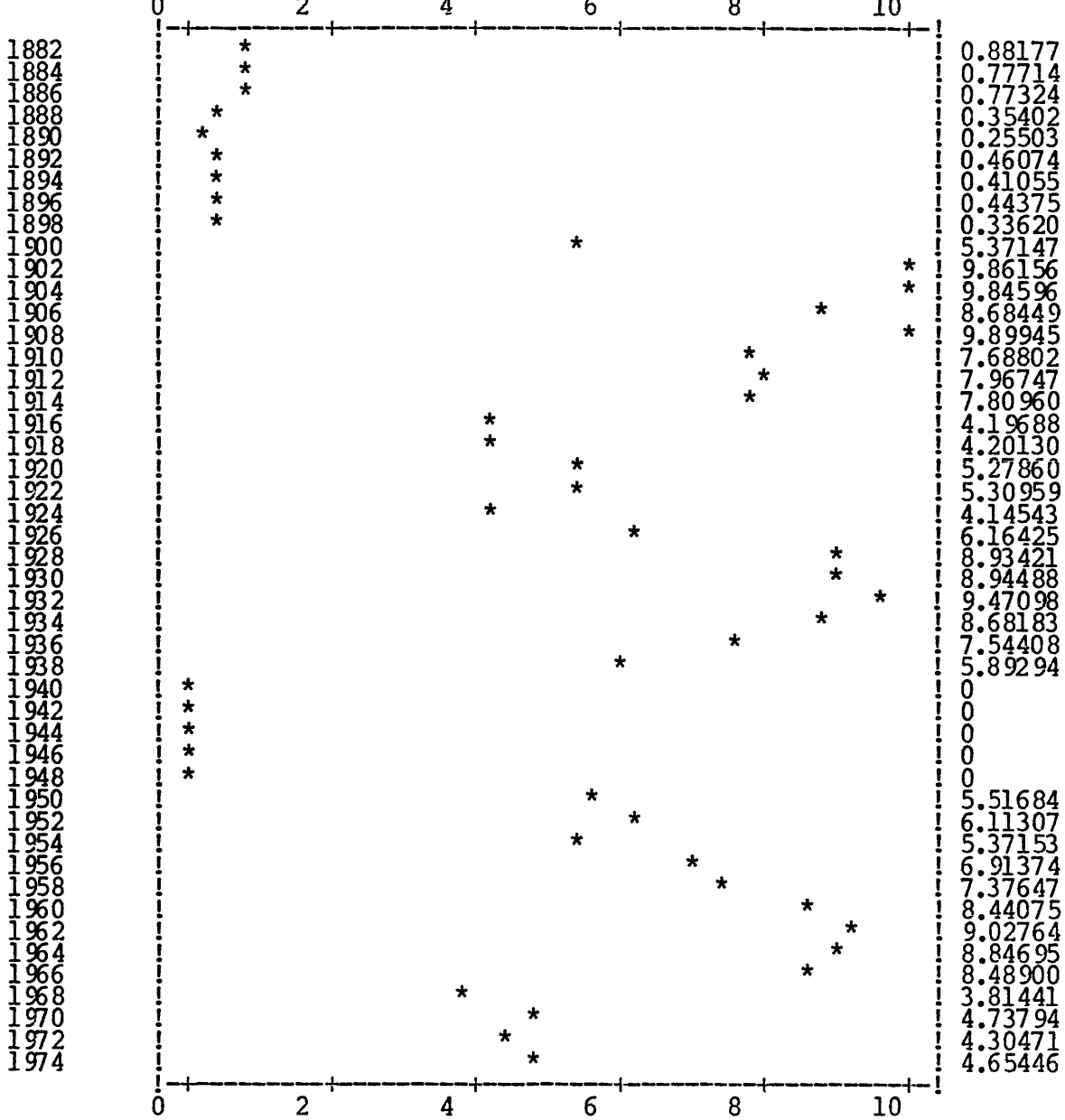

Cl. 44 Habadashery, jewellery; snuff takers and smokers' requisites

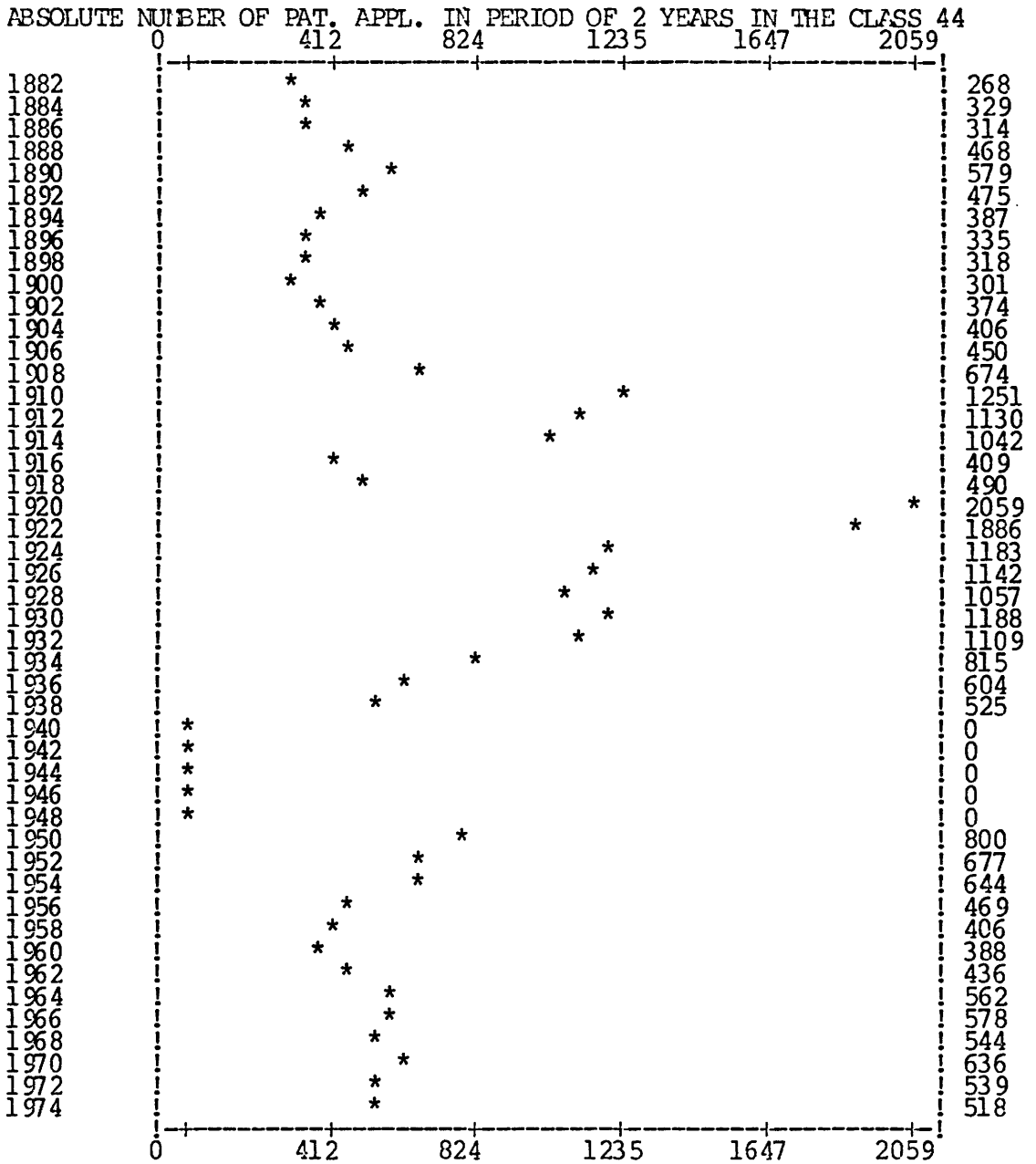

PROPORTION OF TOTAL PAT. APPL. IN 1/1000 IN THE CLASS 44

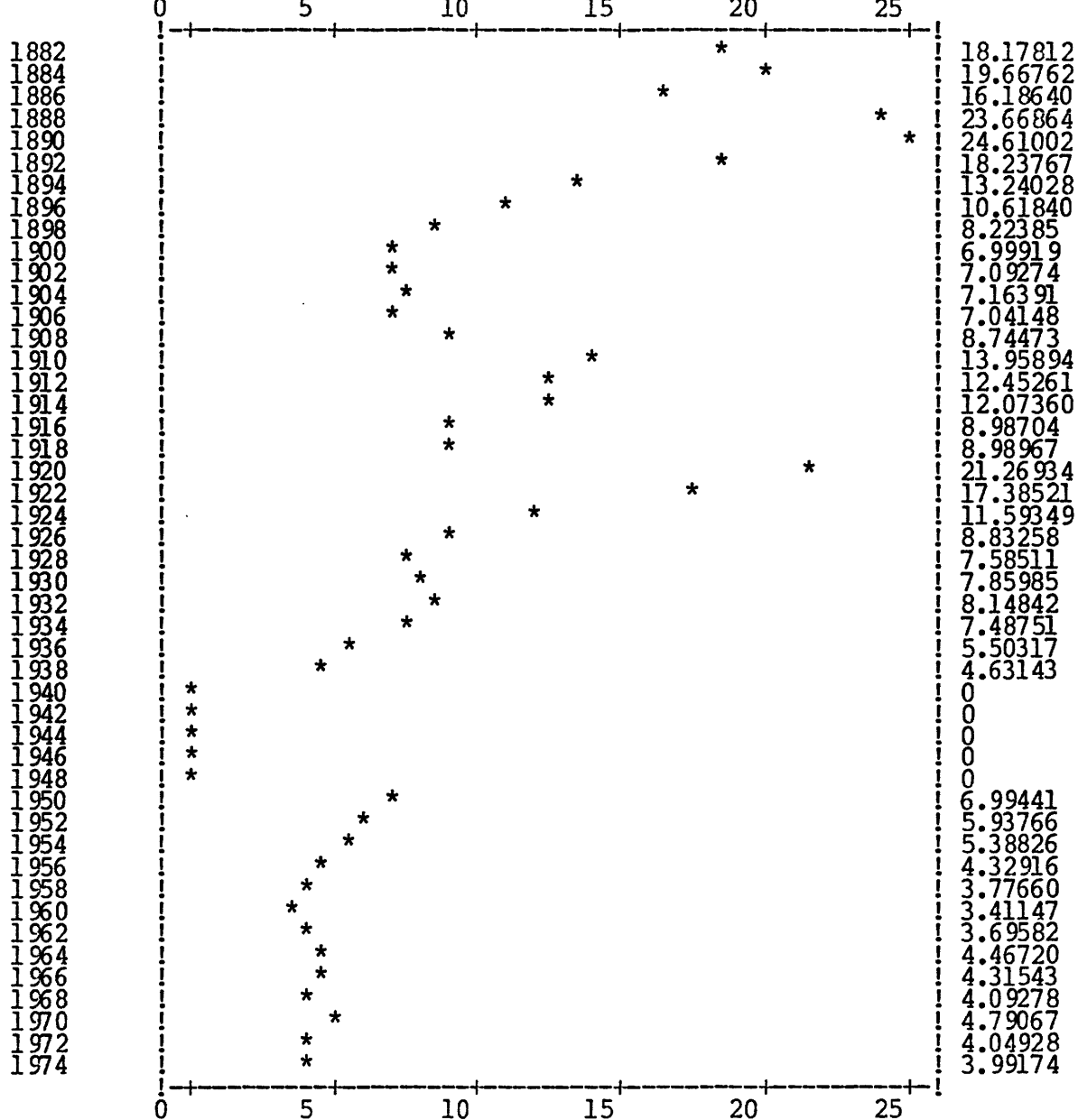



Cl. 45 Agriculture and forestry; animal husbandry; hunting and trapping; fishing

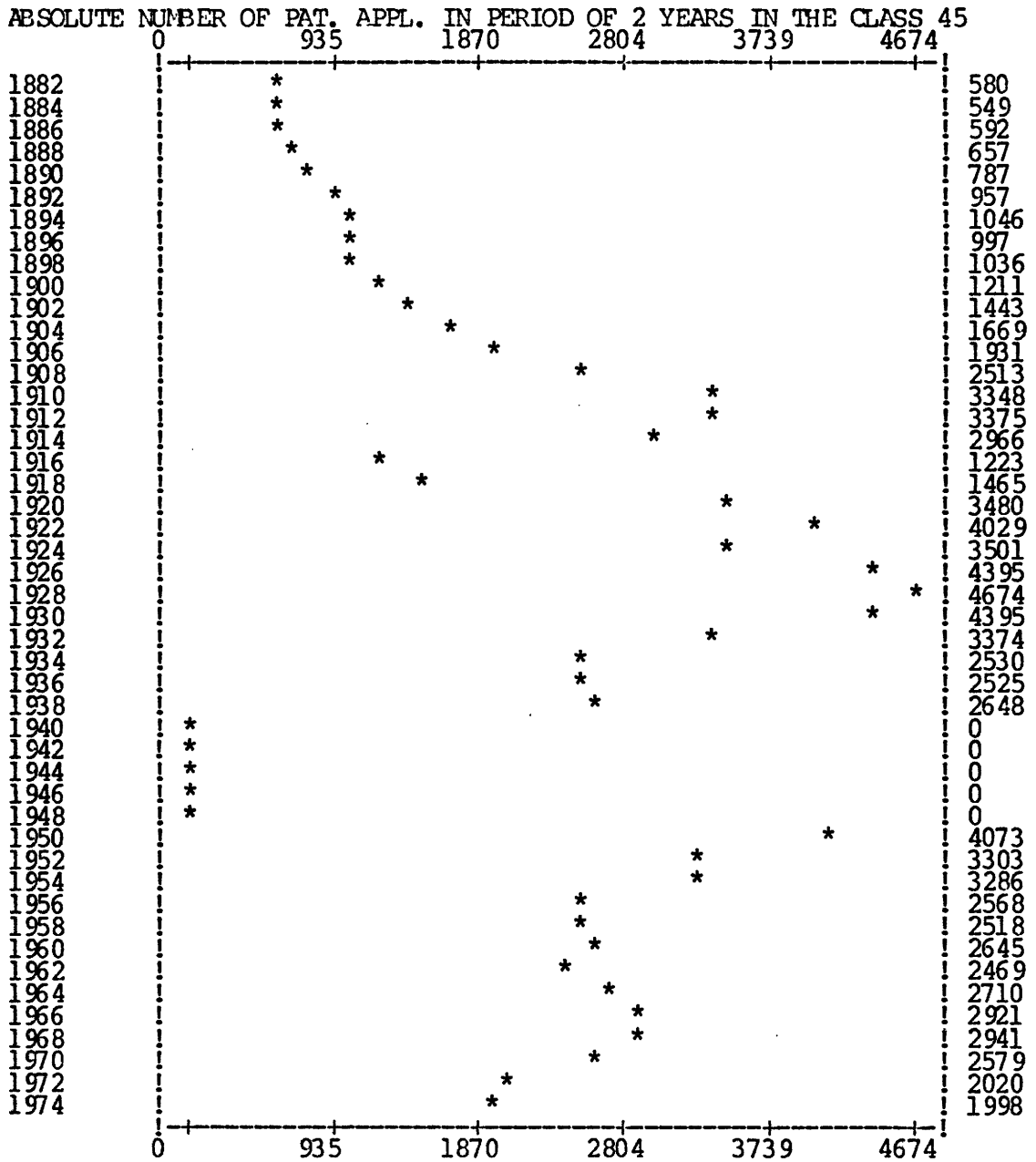

PROPORTION OF TOTAL PAT. APPL. IN 1/1000 IN THE CLASS 45

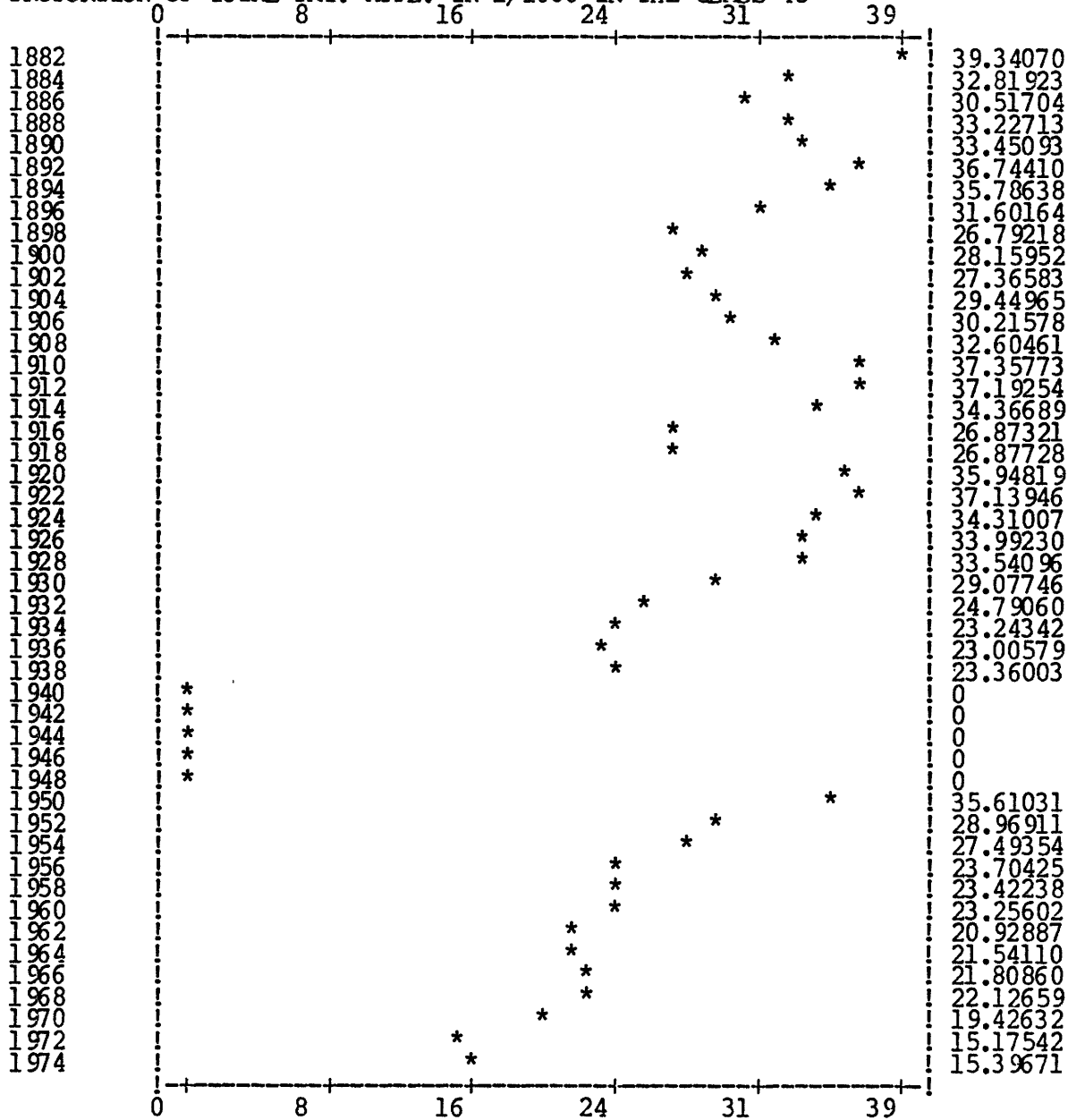

C1. 46 Combustion engines; hot-gas or combustion-product engine plants

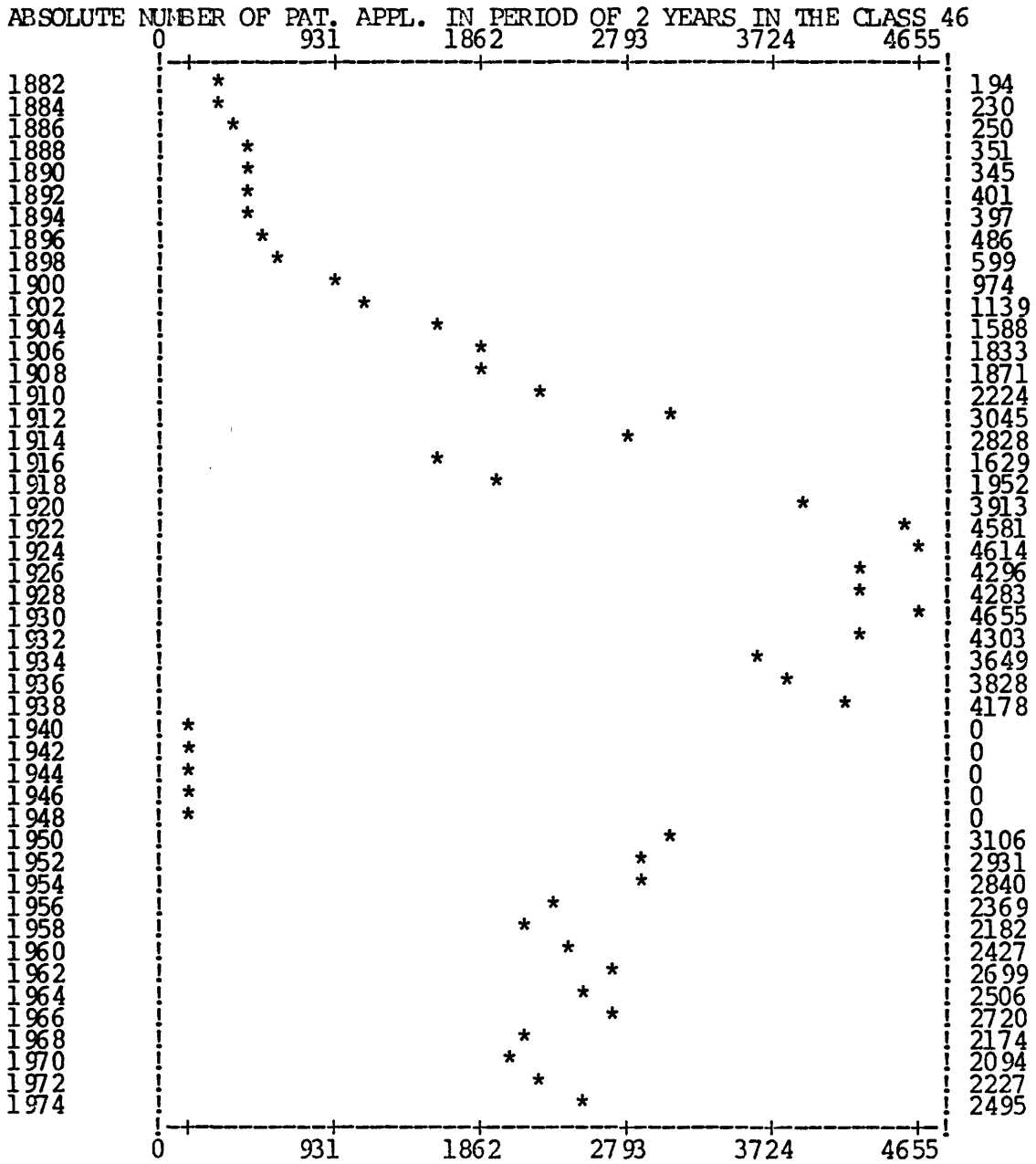

FRANZ KNIE IN BERLIN.

**Einsteckschloß, bei welchem das Öffnen und Schließen der Falle durch Ziehen und Stoßen erfolgt.**

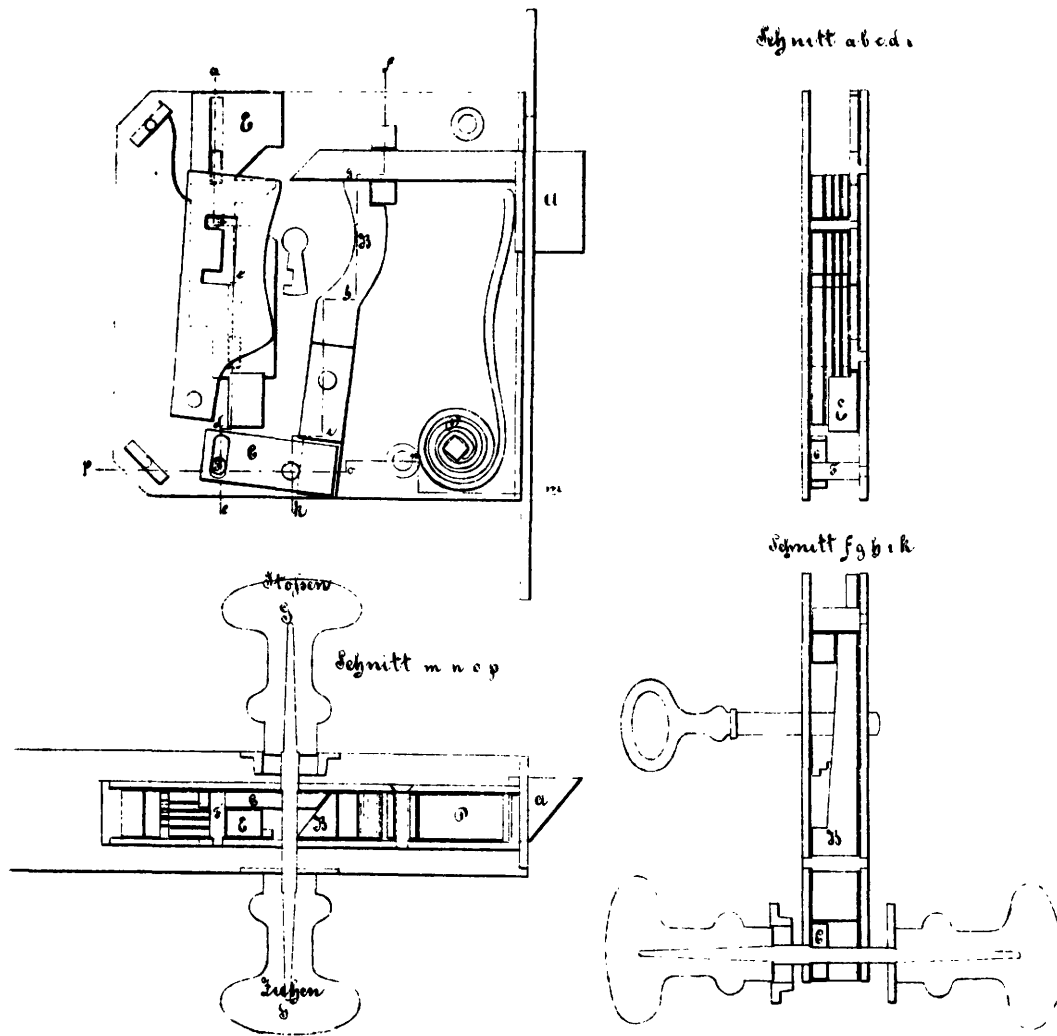

Zu der Patentschrift

**№ 150.**

PHOTGR. DRUCK DER KÖNIGL. PREUSS. STAATSDRUCKEREI.

P. RAUH IN BRESLAU.

Fallenschloß.

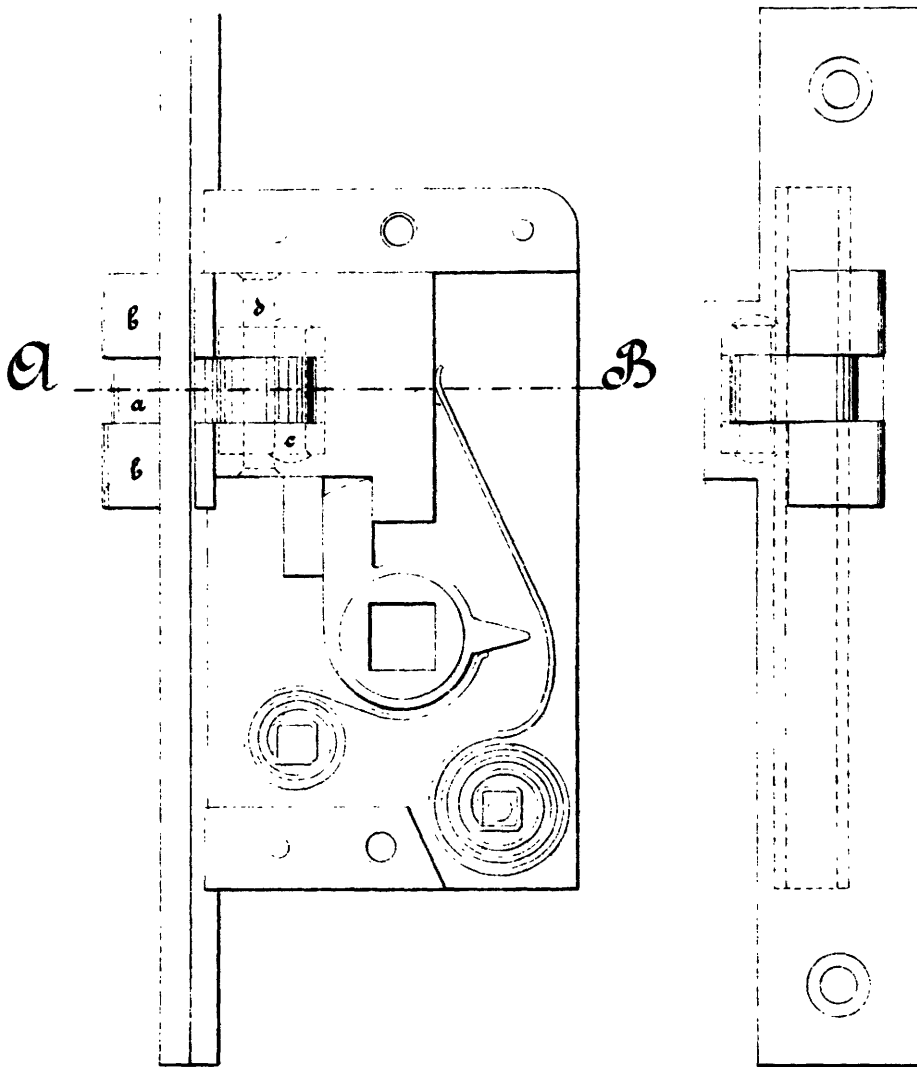

A B.

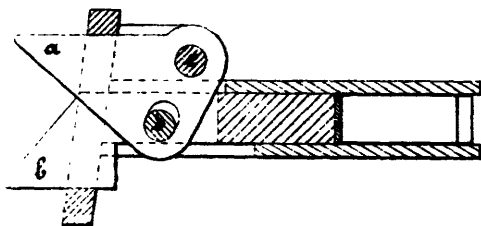

Zu der Patentschrift

№ 139.

PHOTGR. DRUCK DER KÖNIGL. PREUSS. STAATSDRUCKEREI.

PROPORTION OF TOTAL PAT. APPL. IN 1/1000 IN THE CLASS 46

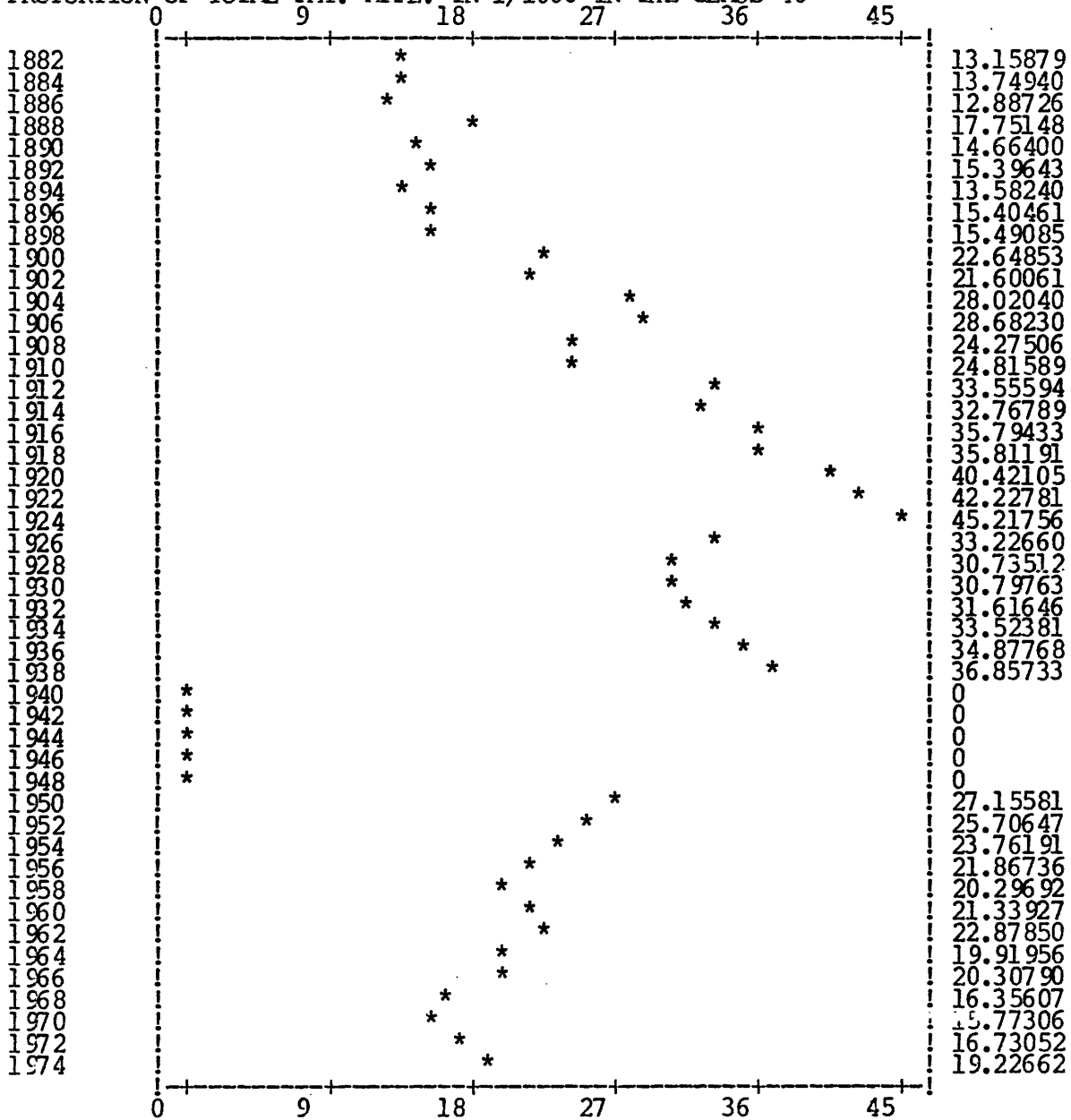

Cl. 47 Engineering elements or units; general measures for producing and maintaining effective functioning of machines or installations; details of instruments

ABSOLUTE NUMBER OF PAT. APPL. IN PERIOD OF 2 YEARS IN THE CLASS 47

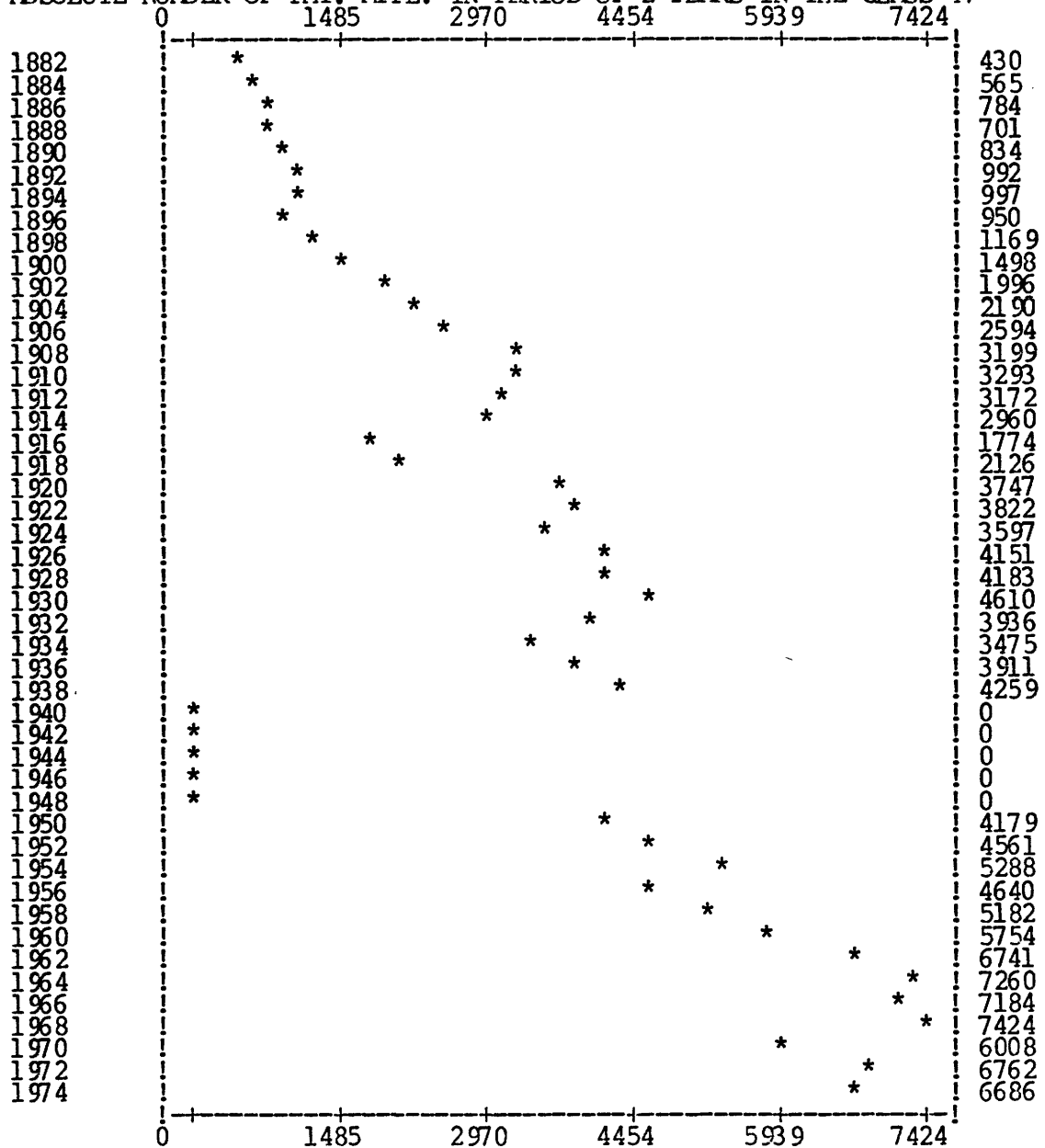

PROPORTION OF TOTAL PAT. APPL. IN 1/1000 IN THE CLASS 47

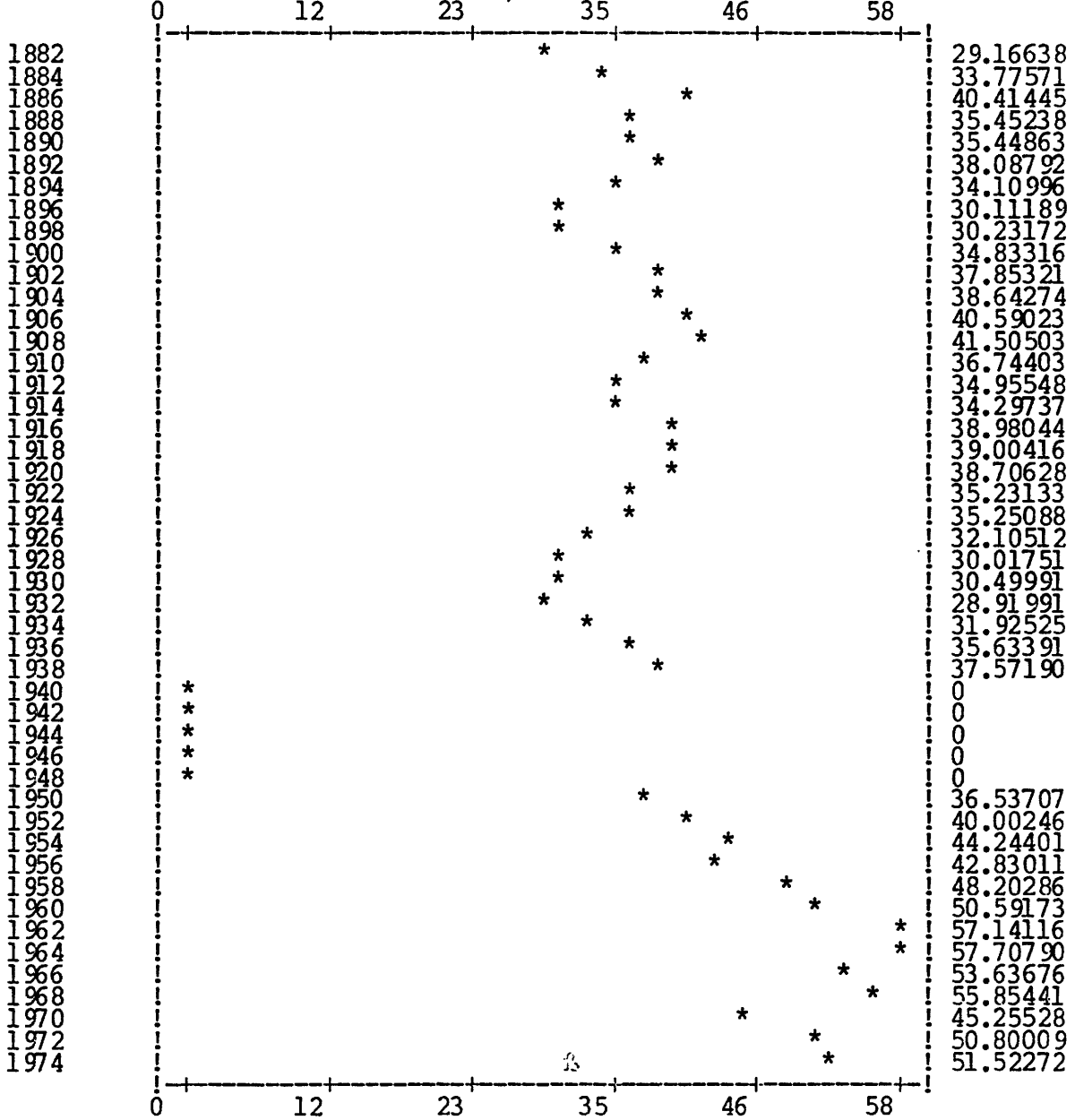



Cl. 48 Working and treatment of metals other than by mechanical means

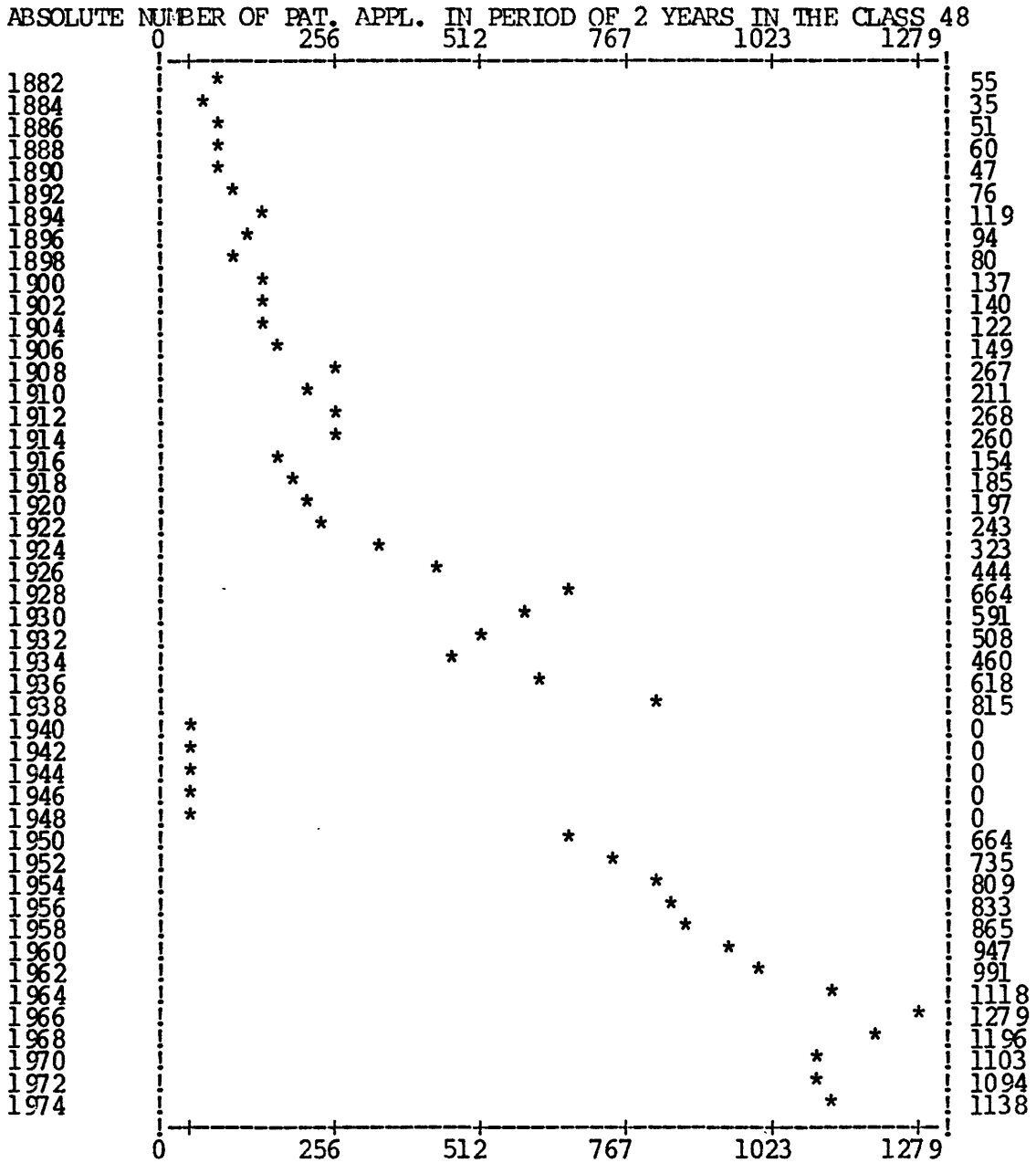

PROPORTION OF TOTAL PAT. APPL. IN 1/1000 IN THE CLASS 48

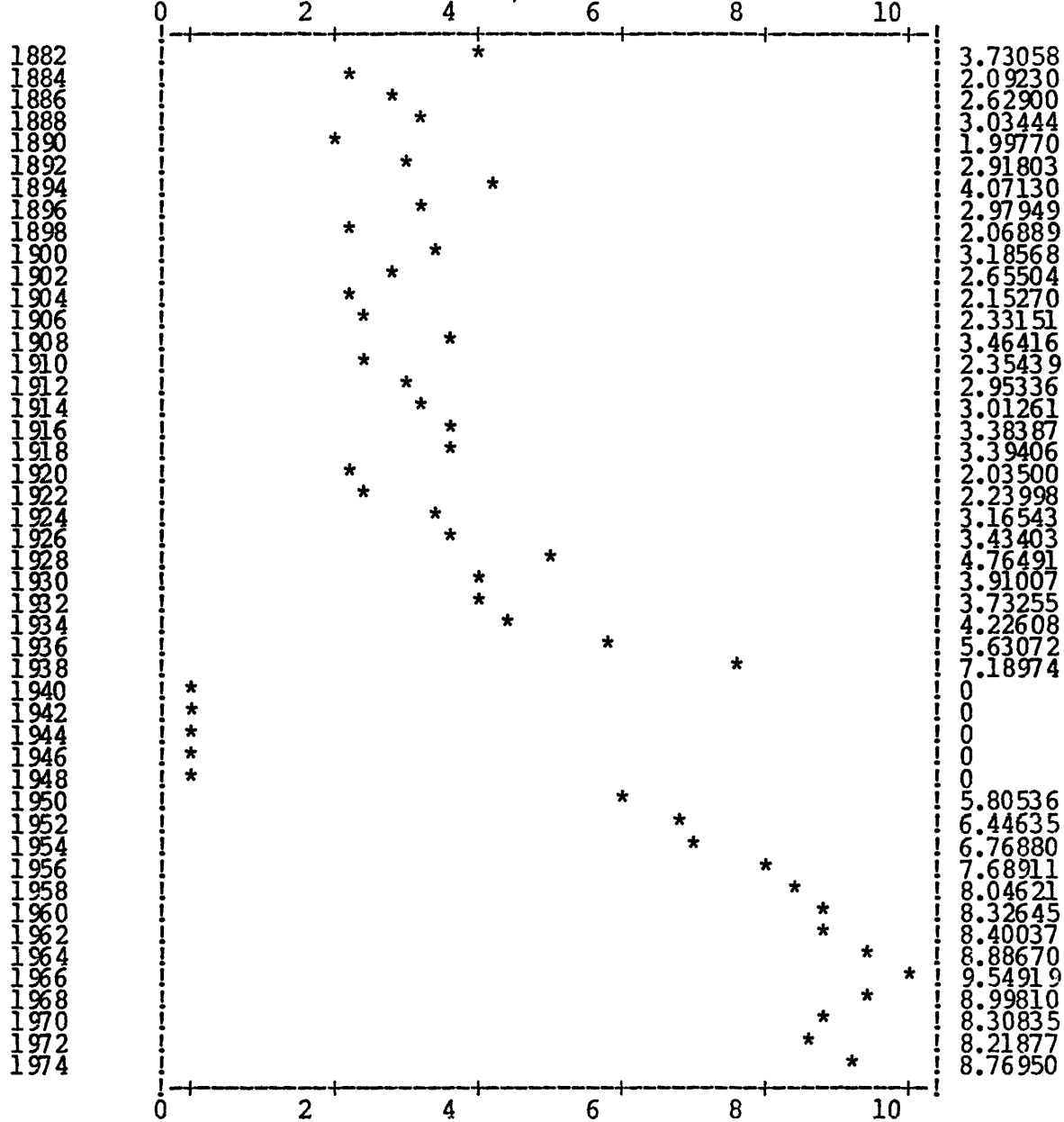

Cl. 49 Machine tools, metal working not otherwise provided for

ABSOLUTE NUMBER OF PAT. APPL. IN PERIOD OF 2 YEARS IN THE CLASS 49

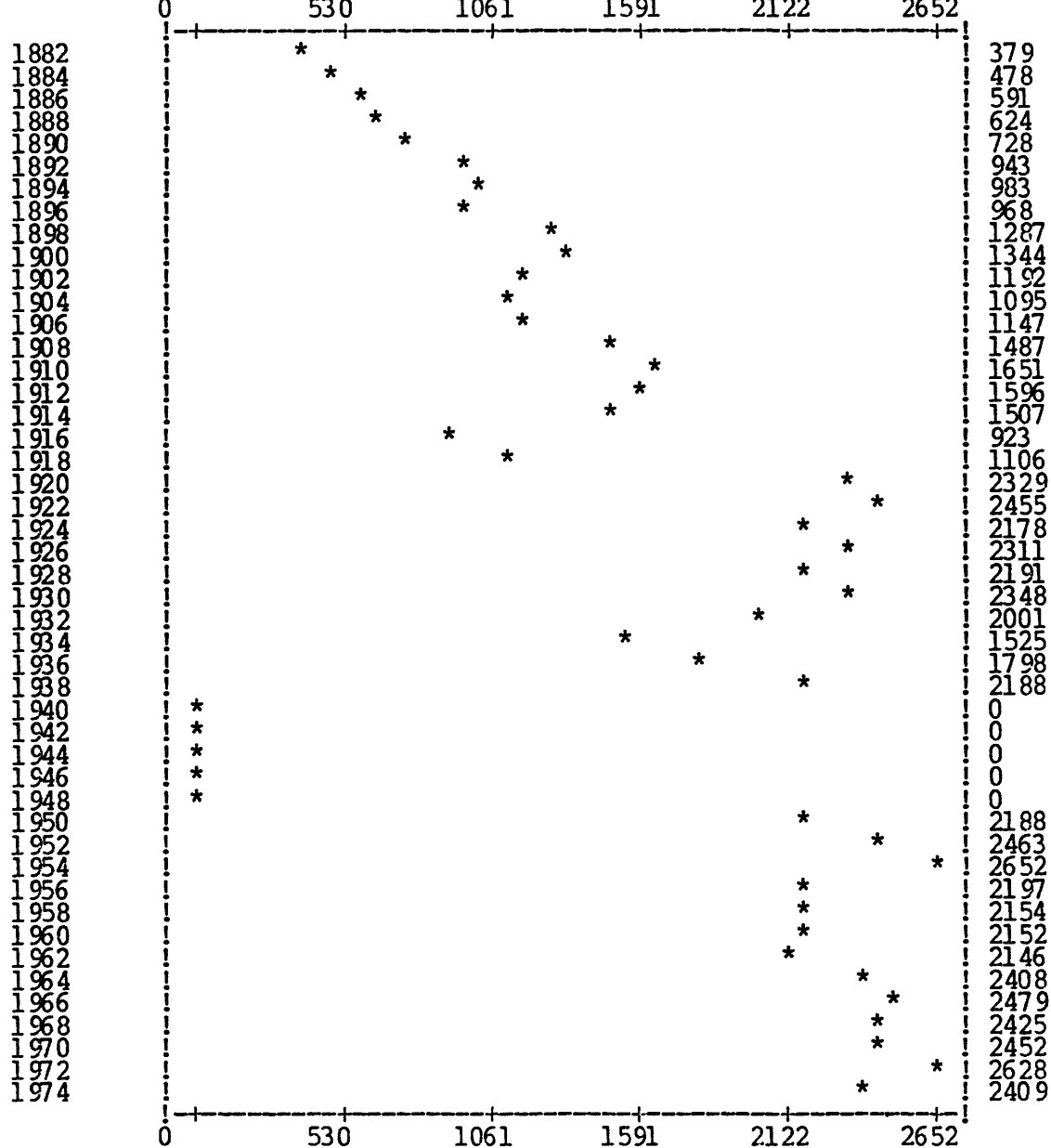

PROPORTION OF TOTAL PAT. APPL. IN 1/1000 IN THE CLASS 49

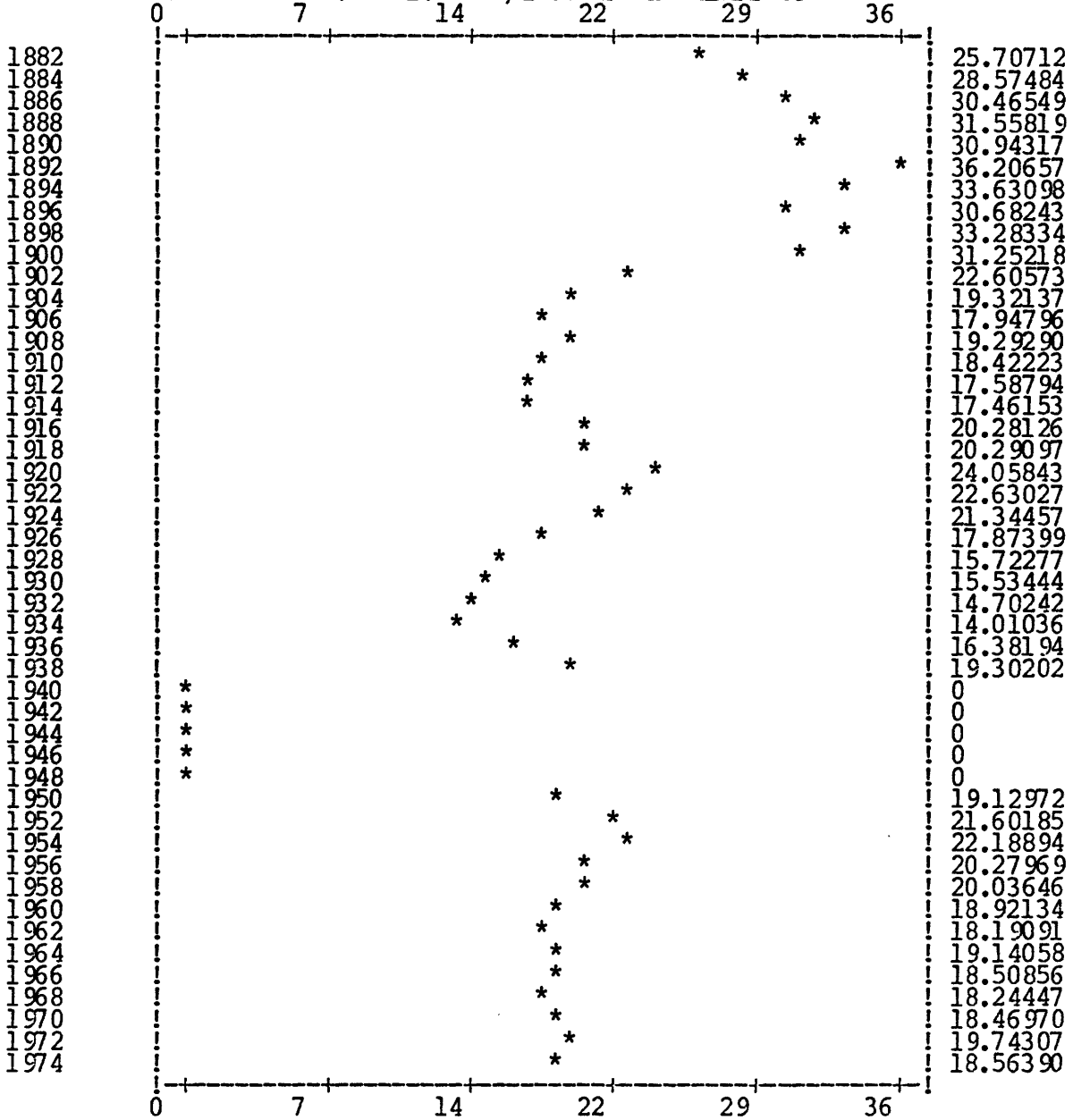

Cl. 50 Grinding and pulverizing including preparatory processes, subsequent treatment of the ground materials by sieving and mixing and separation of matter from the air

ABSOLUTE NUMBER OF PAT. APPL. IN PERIOD OF 2 YEARS IN THE CLASS 50

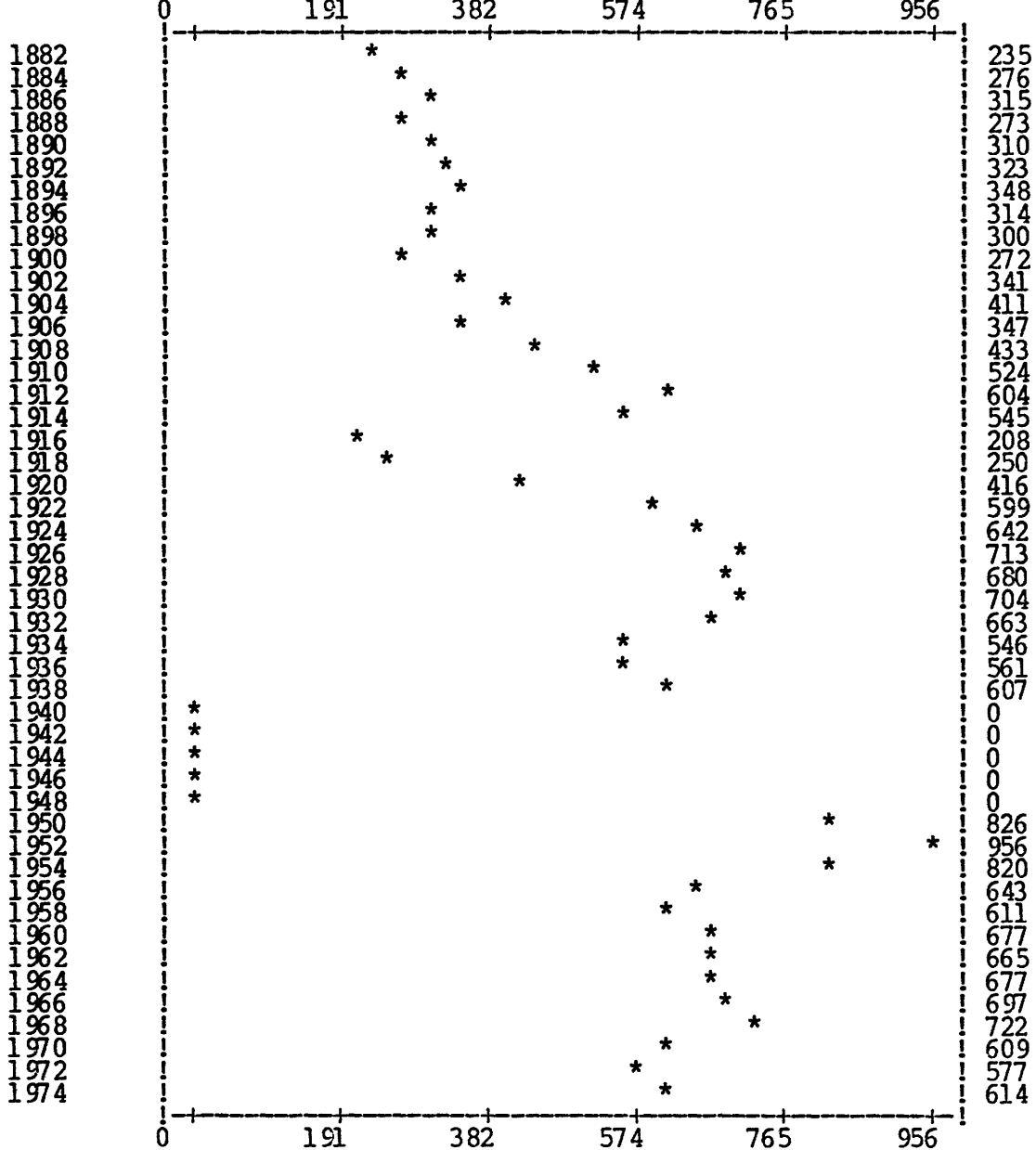

PROPORTION OF TOTAL PAT. APPL. IN 1/1000 IN THE CLASS 50

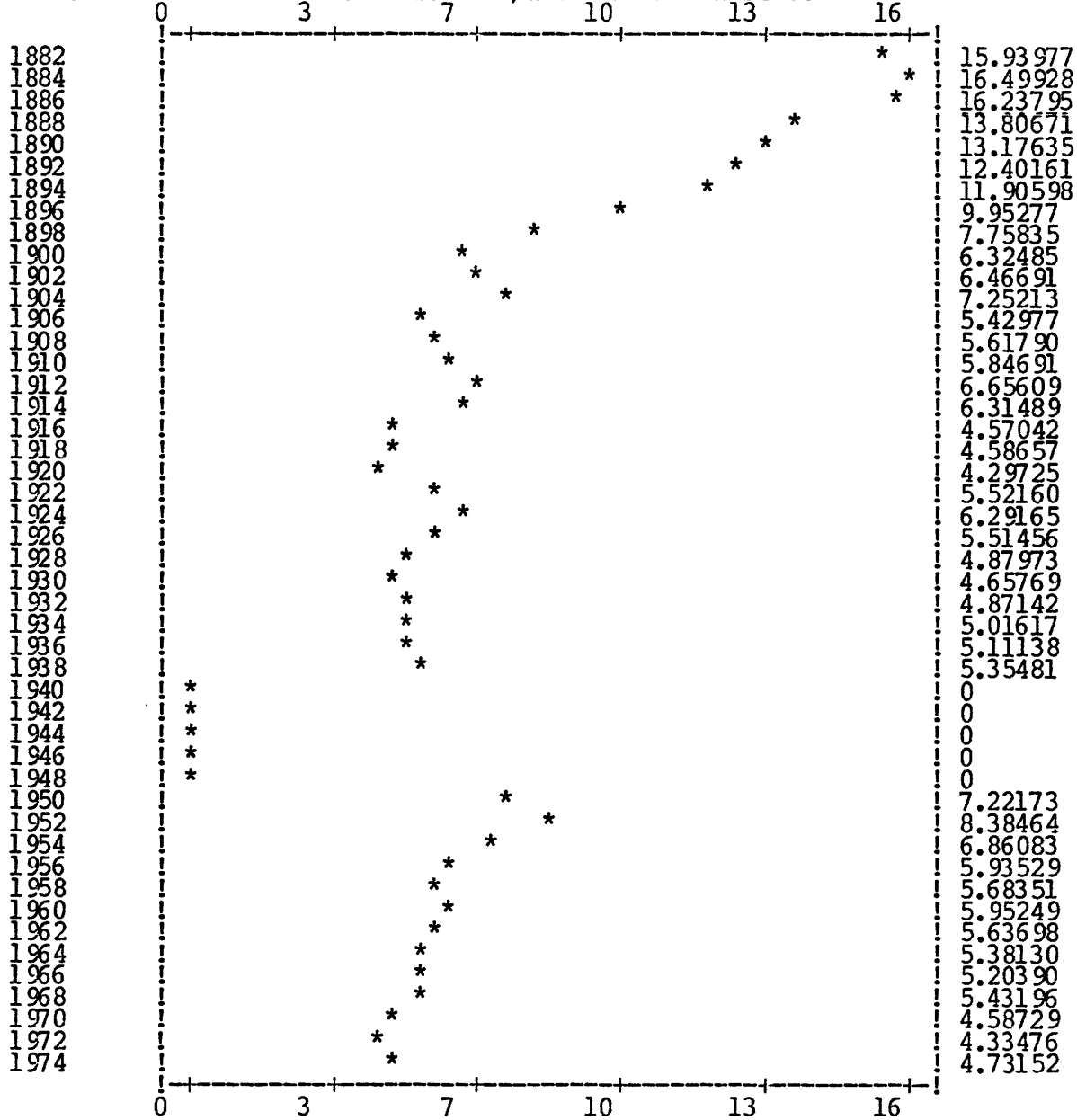

Cl. 51 Musical instruments

ABSOLUTE NUMBER OF PAT. APPL. IN PERIOD OF 2 YEARS IN THE CLASS 51

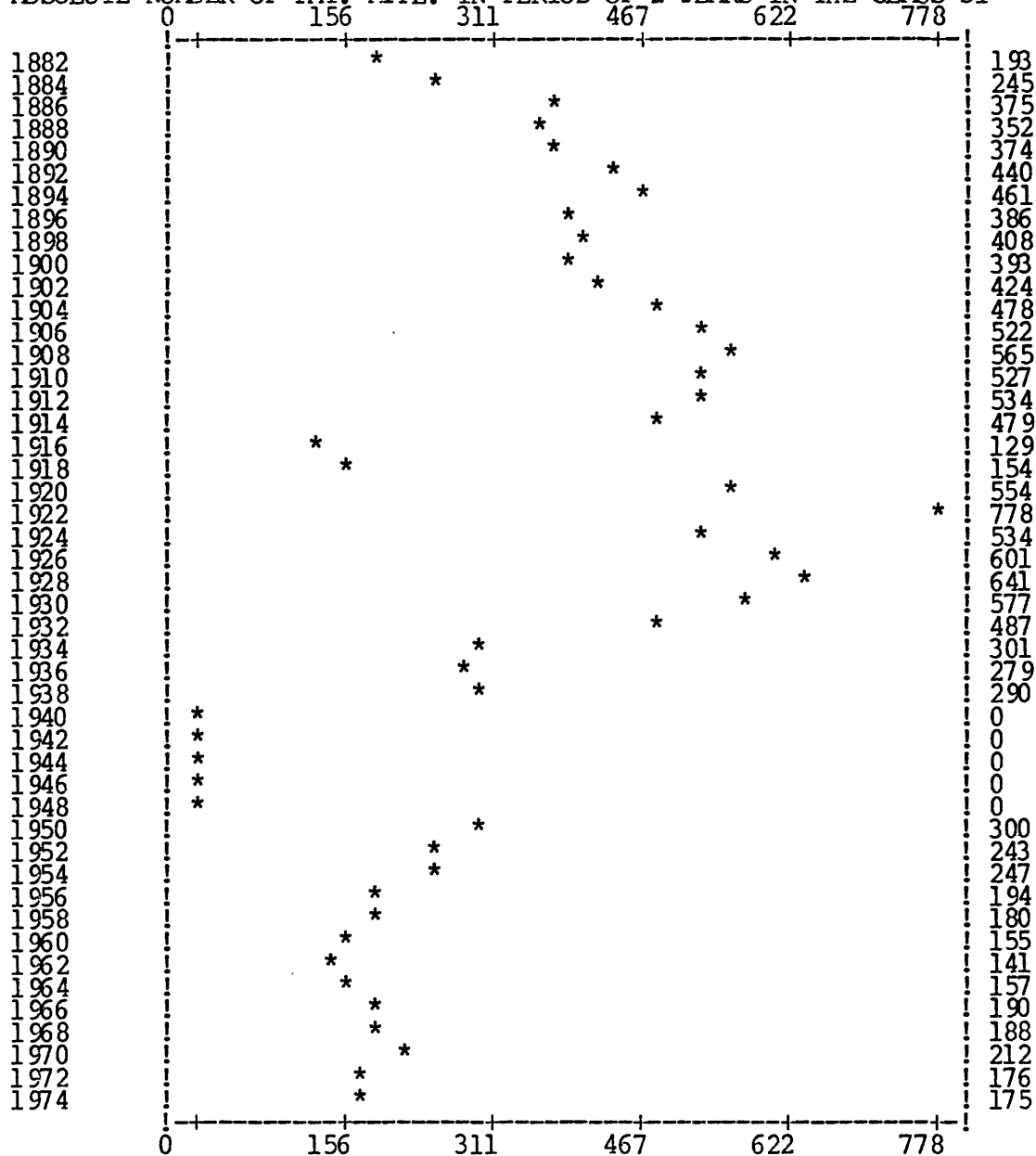

PROPORTION OF TOTAL PAT. APPL. IN 1/1000 IN THE CLASS 51

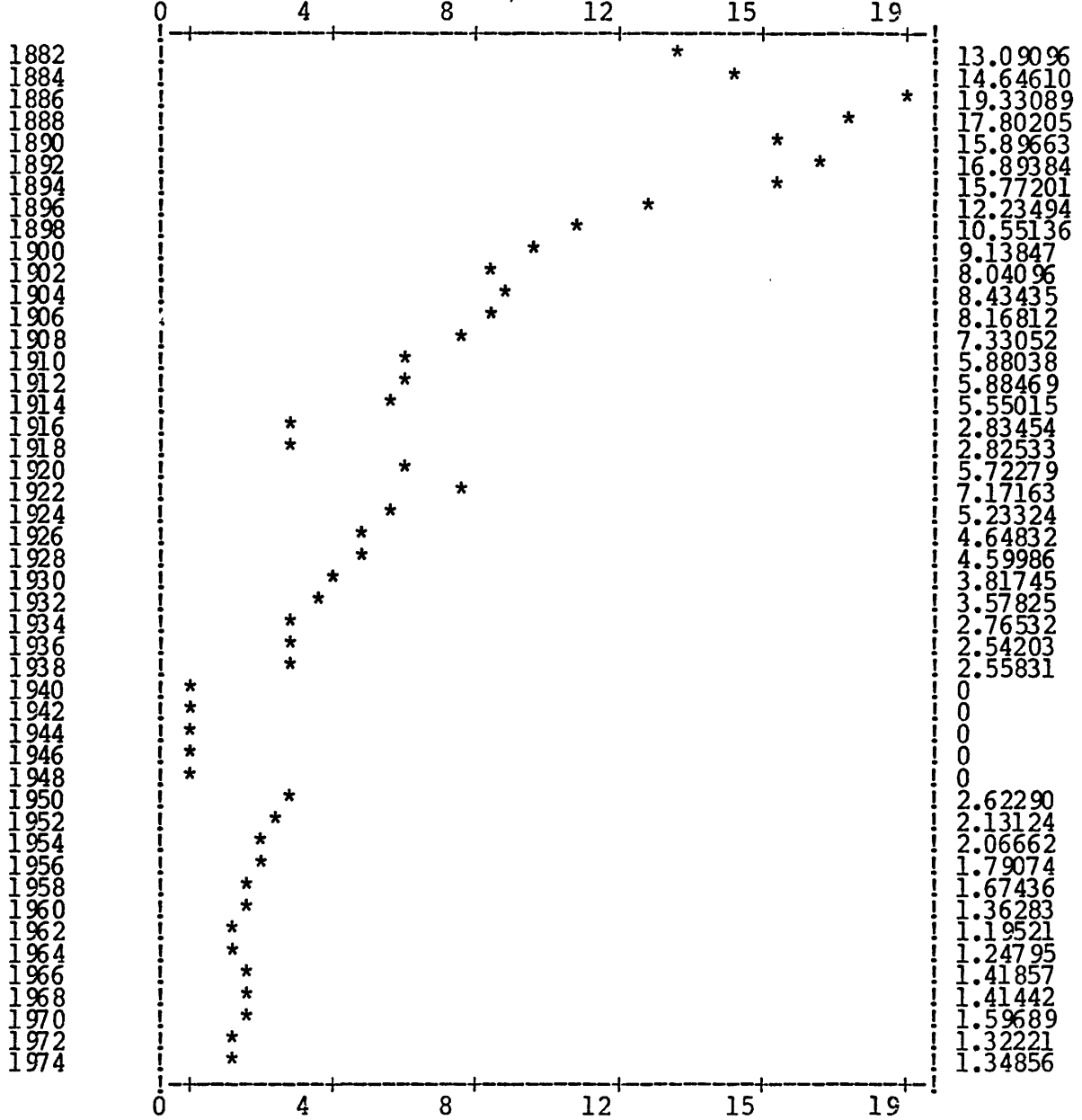



Cl. 52 Sewing and embroidering

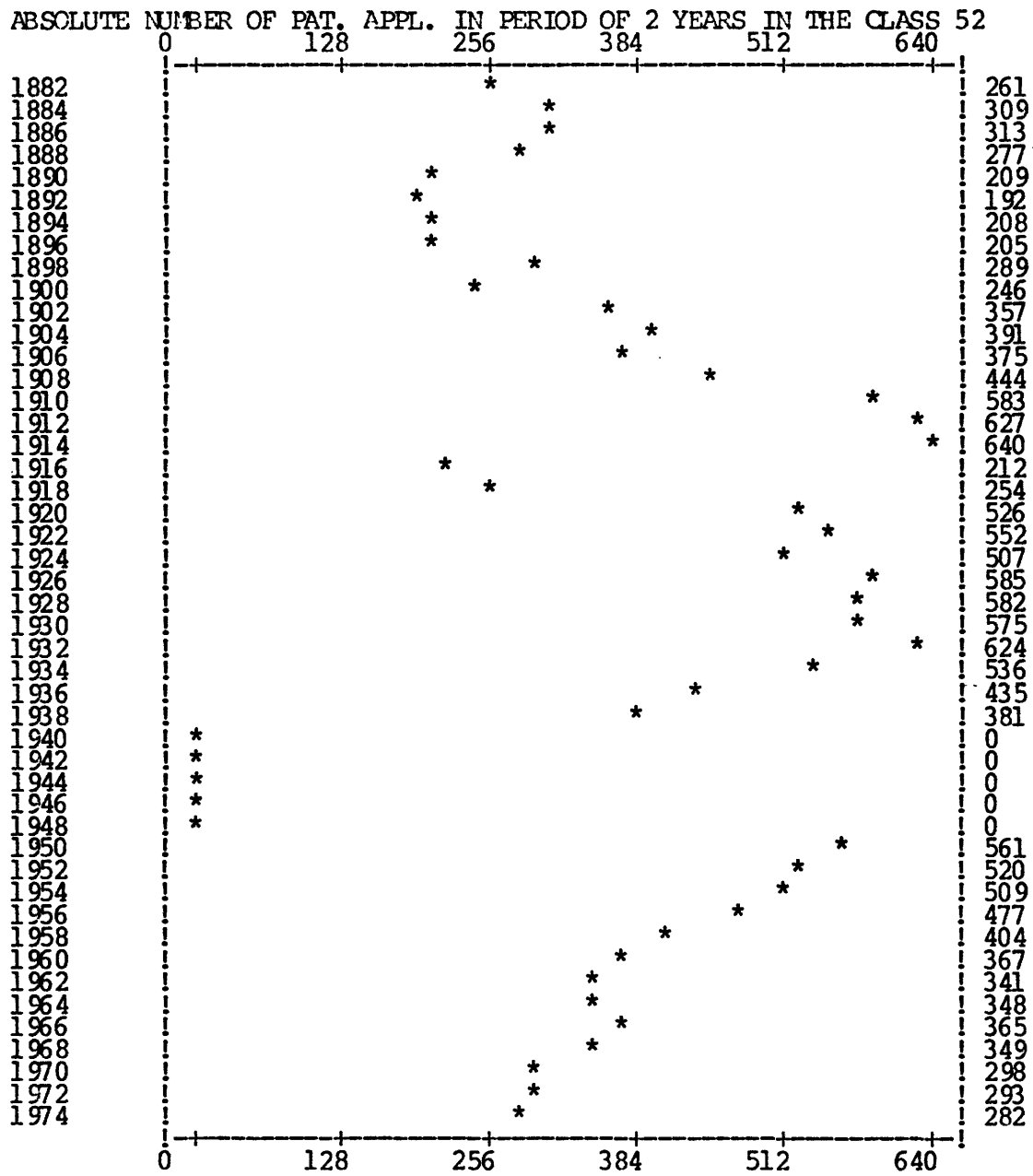

PROPORTION OF TOTAL PAT. APPL. IN 1/1000 IN THE CLASS 52

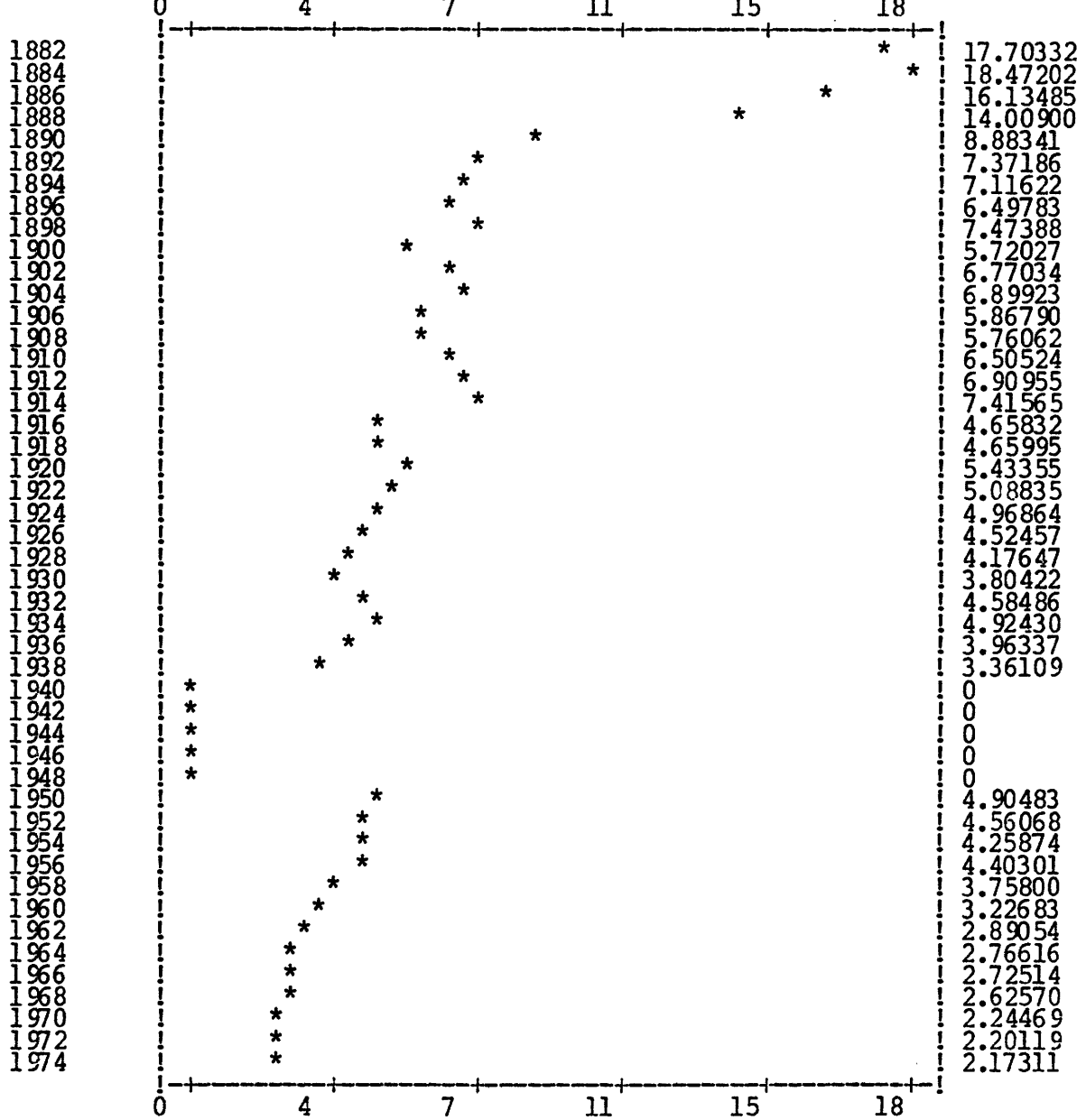

Cl. 53 Foods and foodstuffs not included in special classes, feeding stuffs

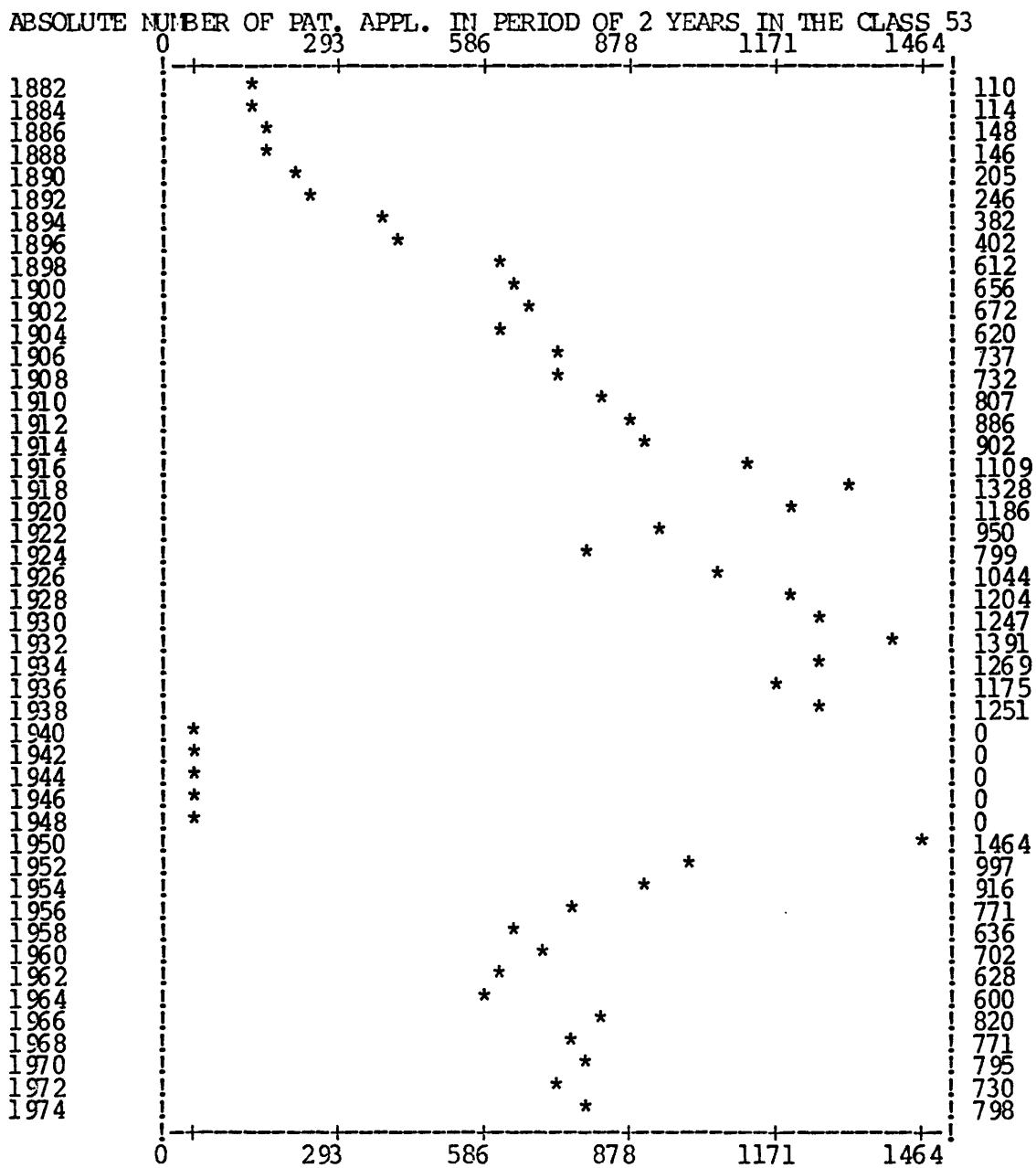

PROPORTION OF TOTAL PAT. APPL. IN 1/1000 IN THE CLASS 53

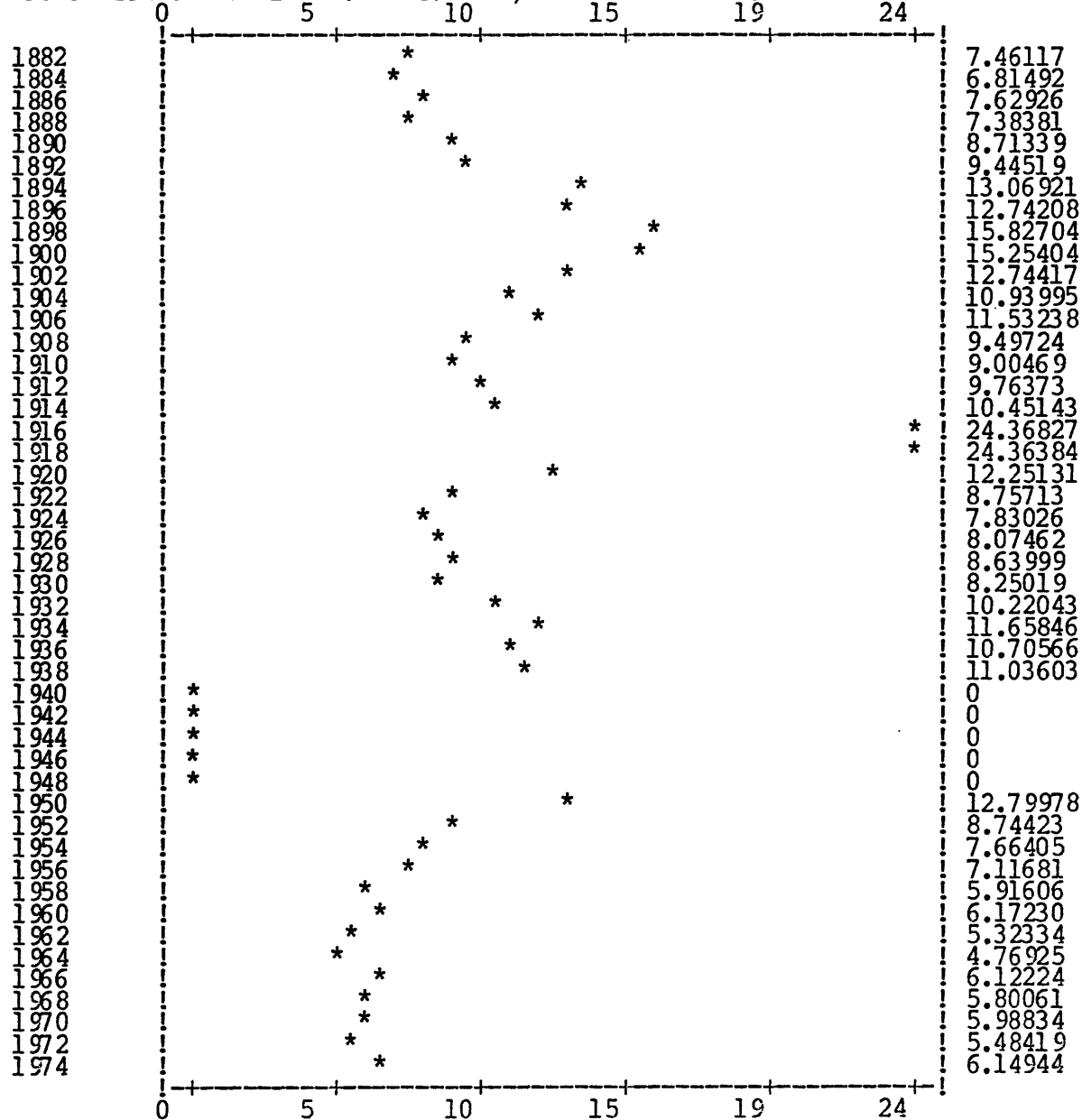

Cl. 54 Working of paper and board and products thereof as well as advertising material

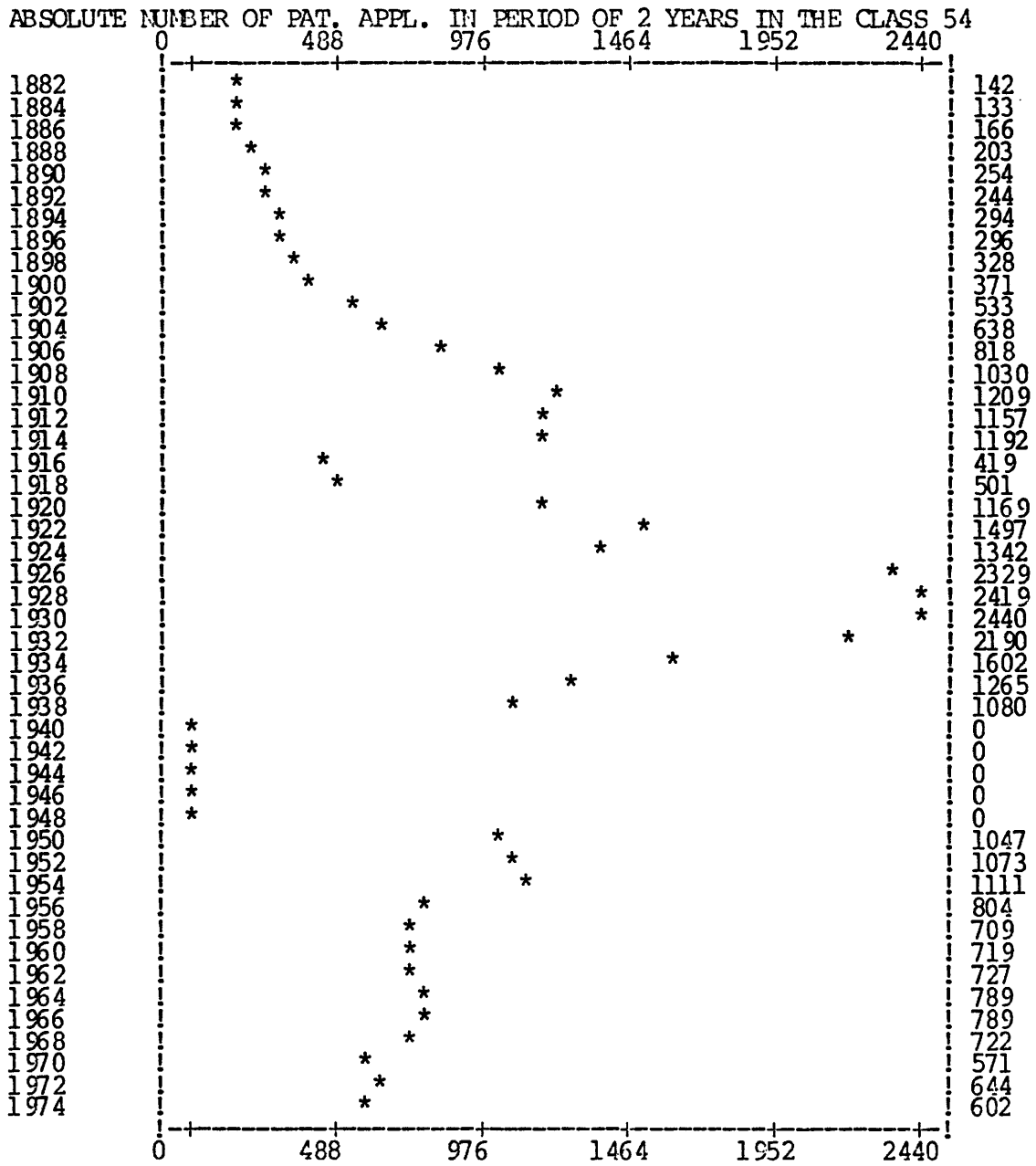

PROPORTION OF TOTAL PAT. APPL. IN 1/1000 IN THE CLASS 54

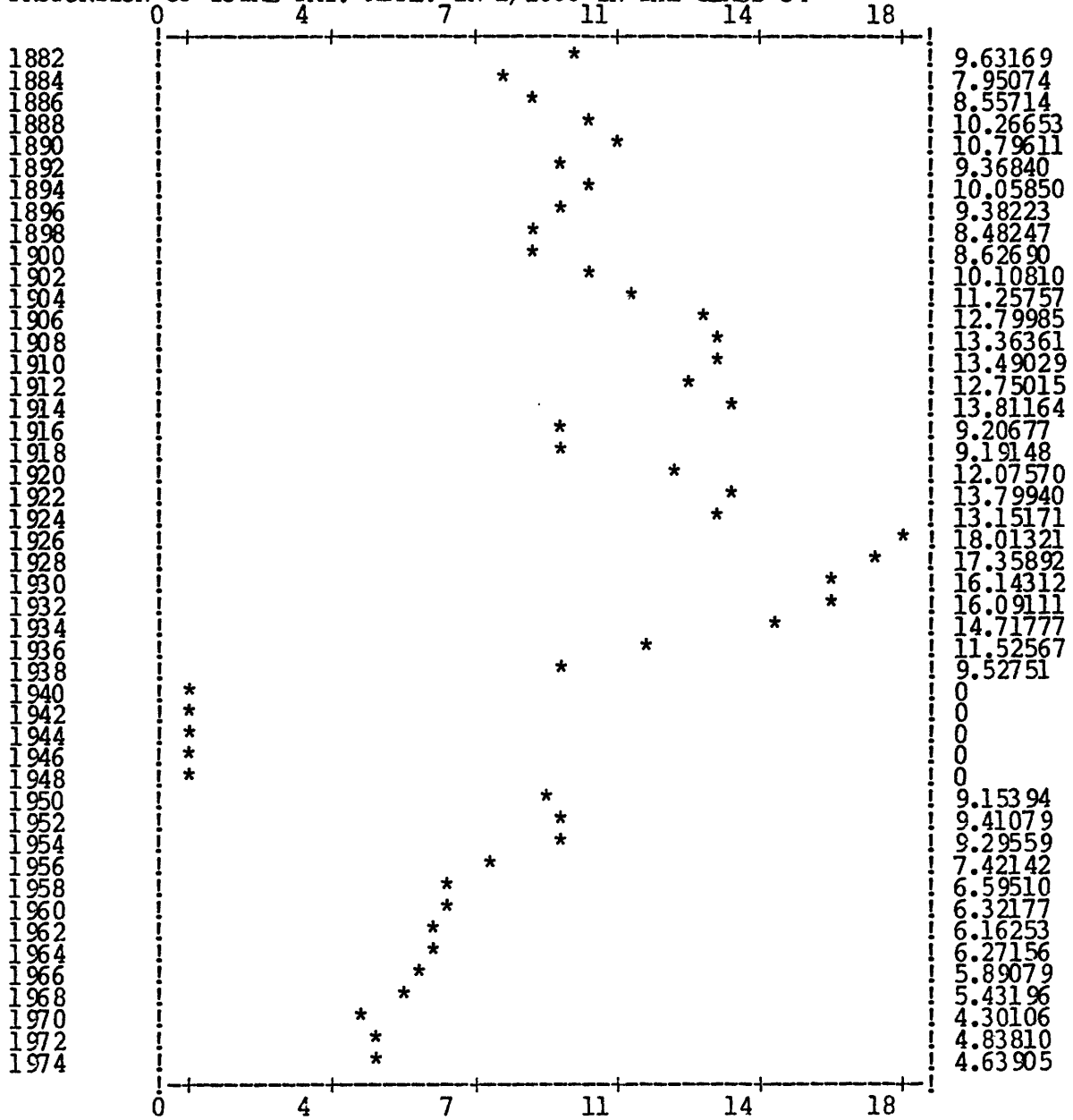

Cl. 55 Production of cellulose, paper and board

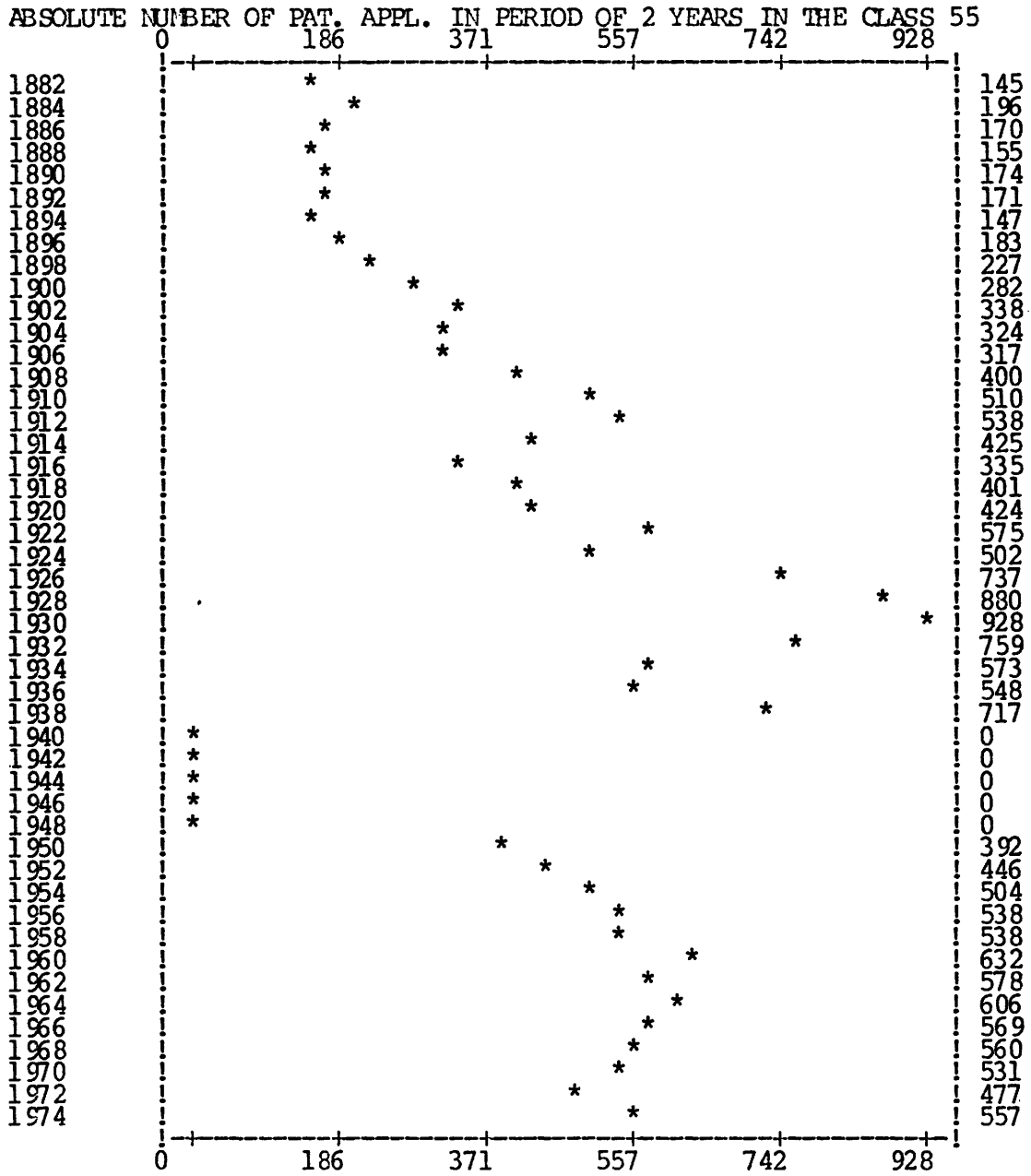

HEINRICH JARCK IN FLENSBURG.

Verschließbares Tintenfass.

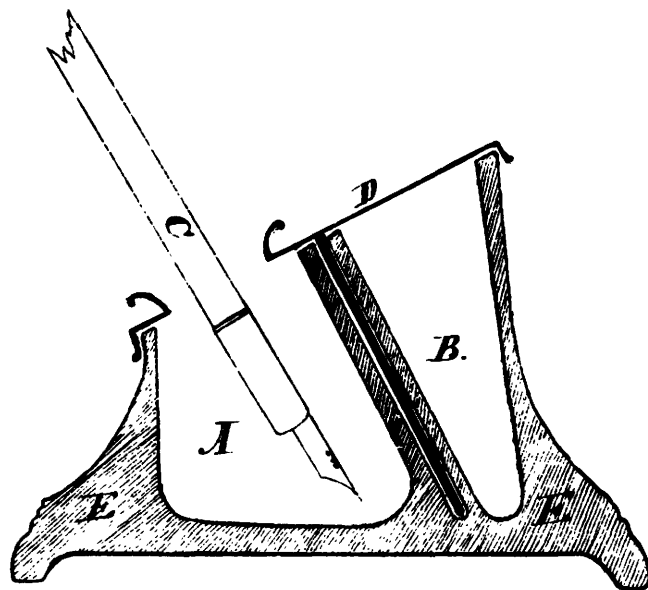
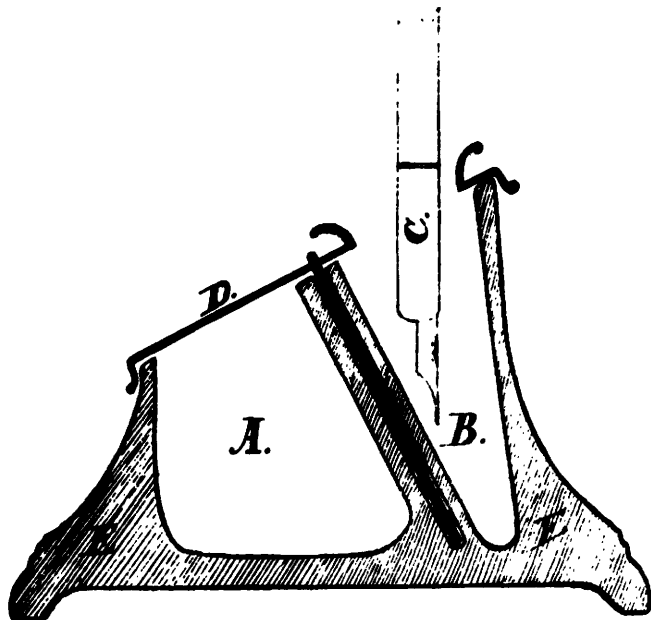

Zu der Patentschrift

№ 87.

PHOTOGR. DRUCK DER KÖNIGL. PREUSS. STAATSDRUCKEREI.



C. W. HUNOLD IN CHEMNITZ.

Verbesserung an Spulmaschinen.

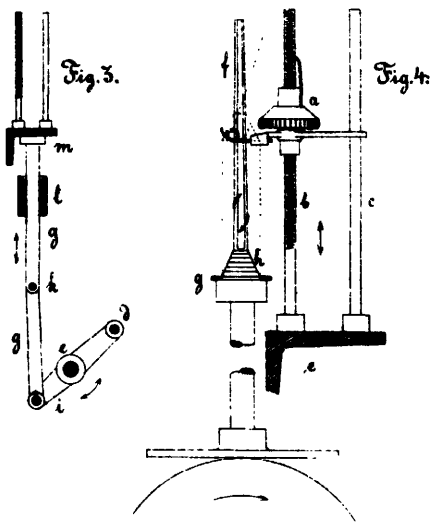
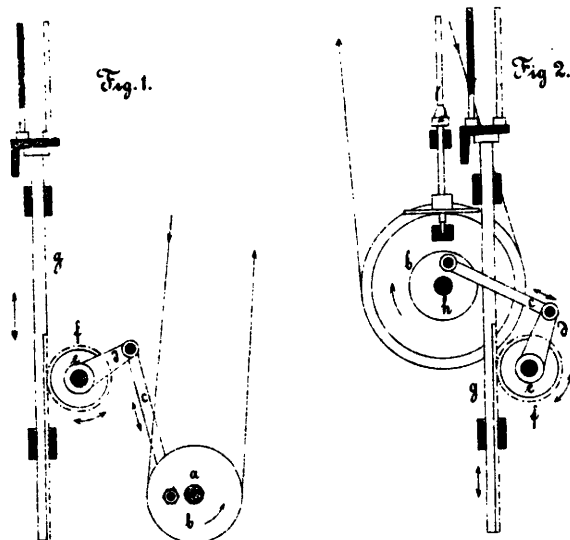

Zu der Patentschrift

№ 177.

PHOTQGR. DRUCK DER KÖNIGL. PREUSS. STAATSDRUCKEREI.

PROPORTION OF TOTAL PAT. APPL. IN 1/1000 IN THE CLASS 55

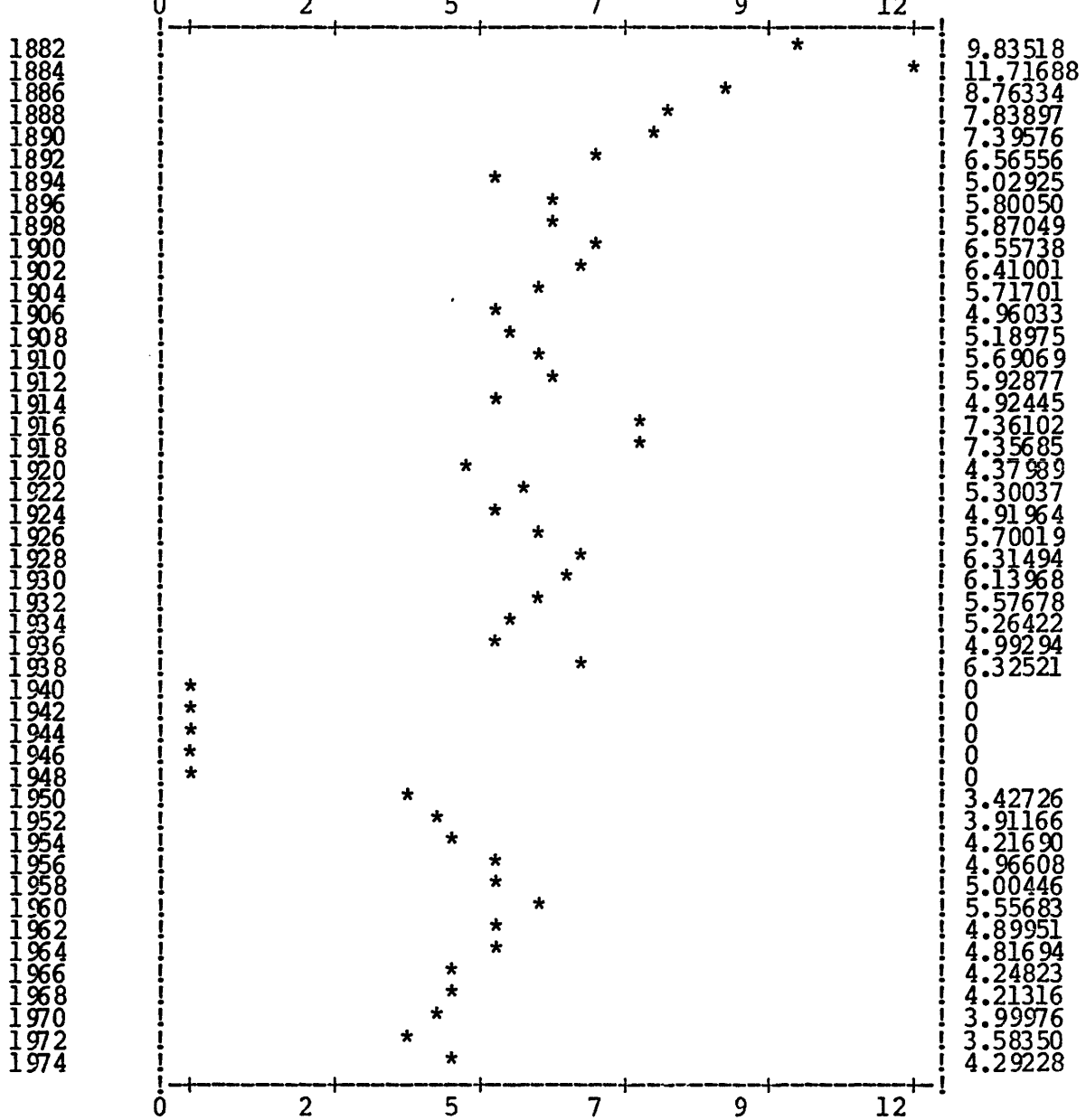

Cl. 56 Upholstery and saddlery

ABSOLUTE NUMBER OF PAT. APPL. IN PERIOD OF 2 YEARS IN THE CLASS 56

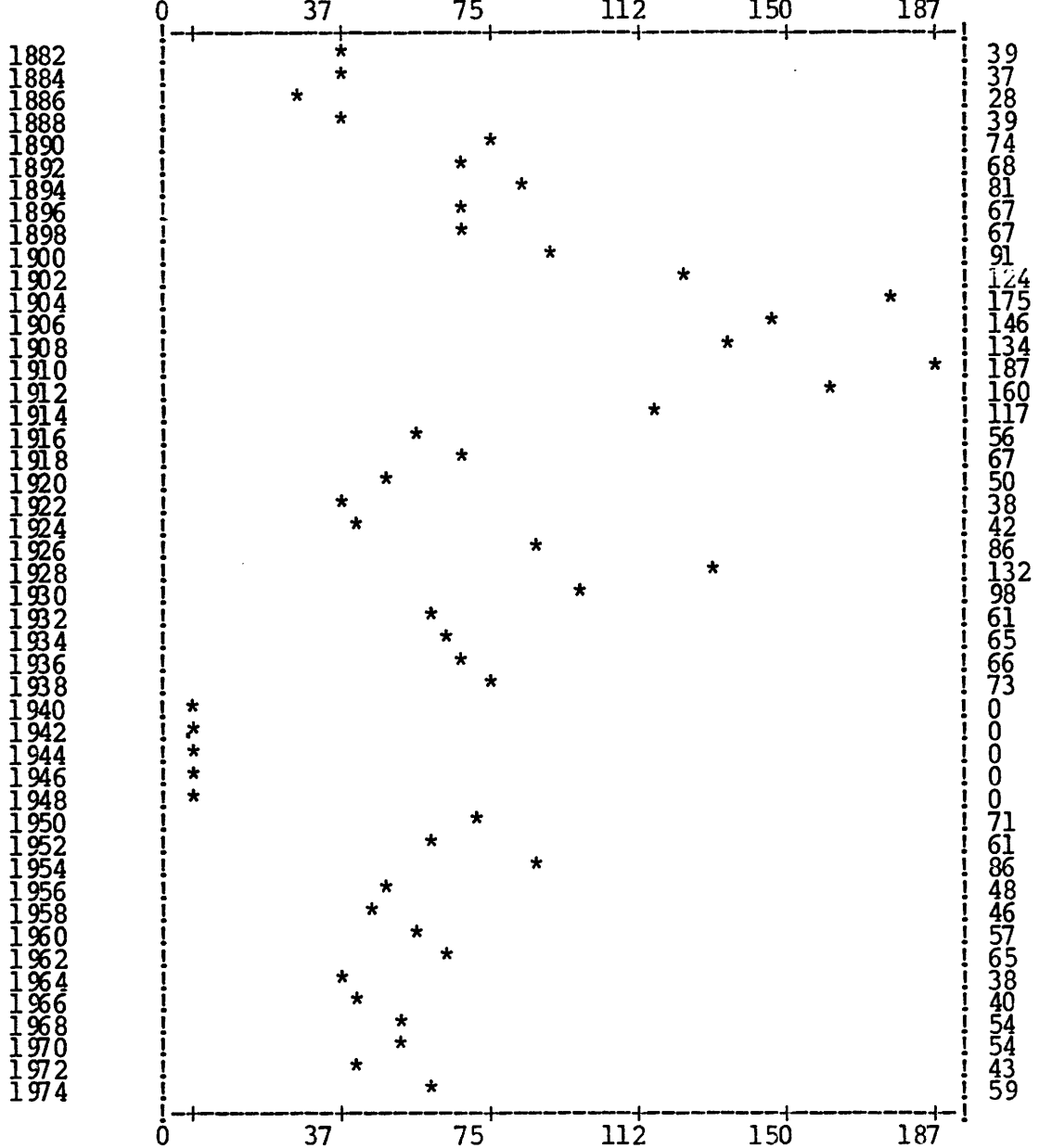

PROPORTION OF TOTAL PAT. APPL. IN 1/1000 IN THE CLASS 56

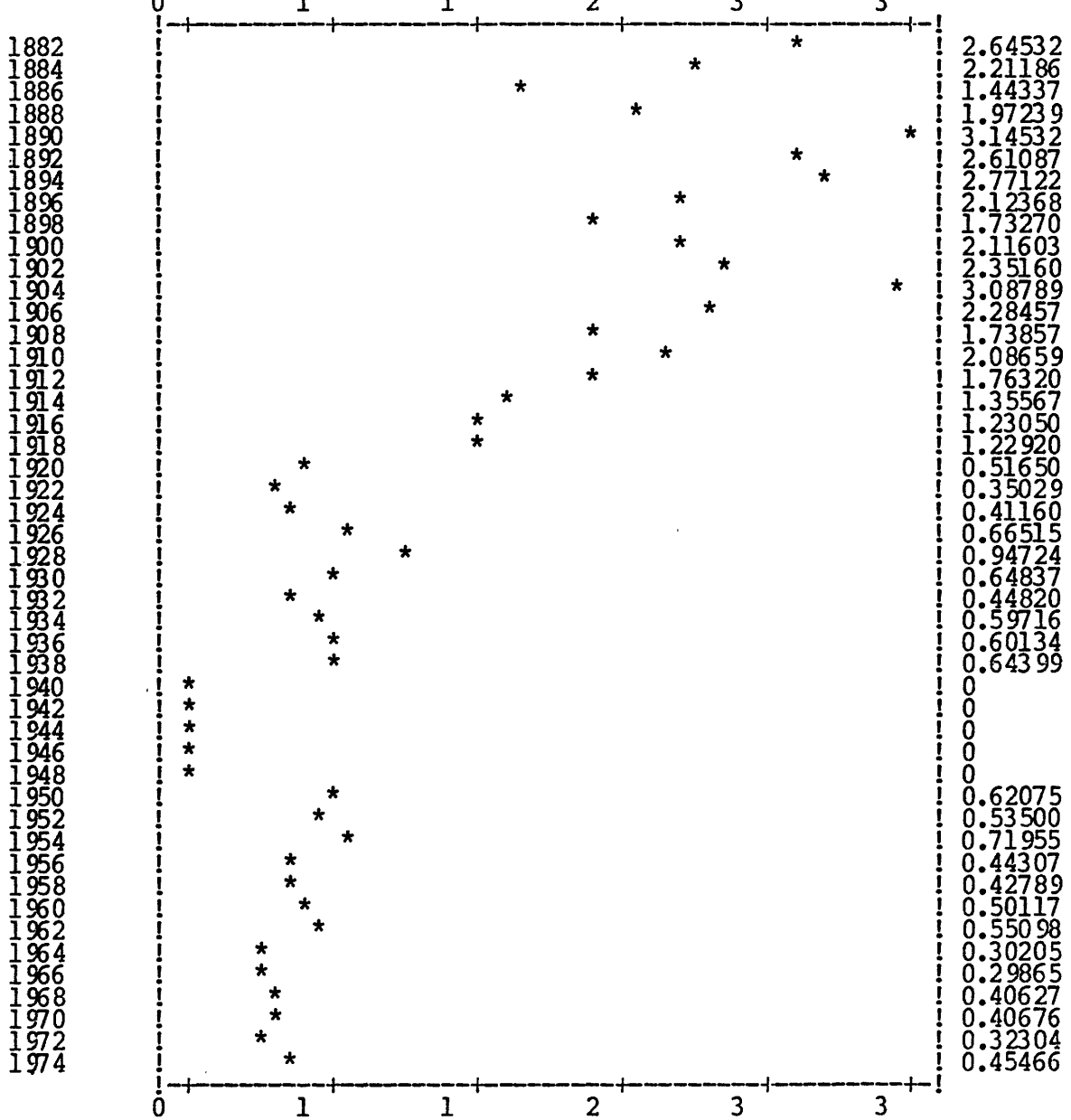

Cl. 57 Photography, cinematography and sound film

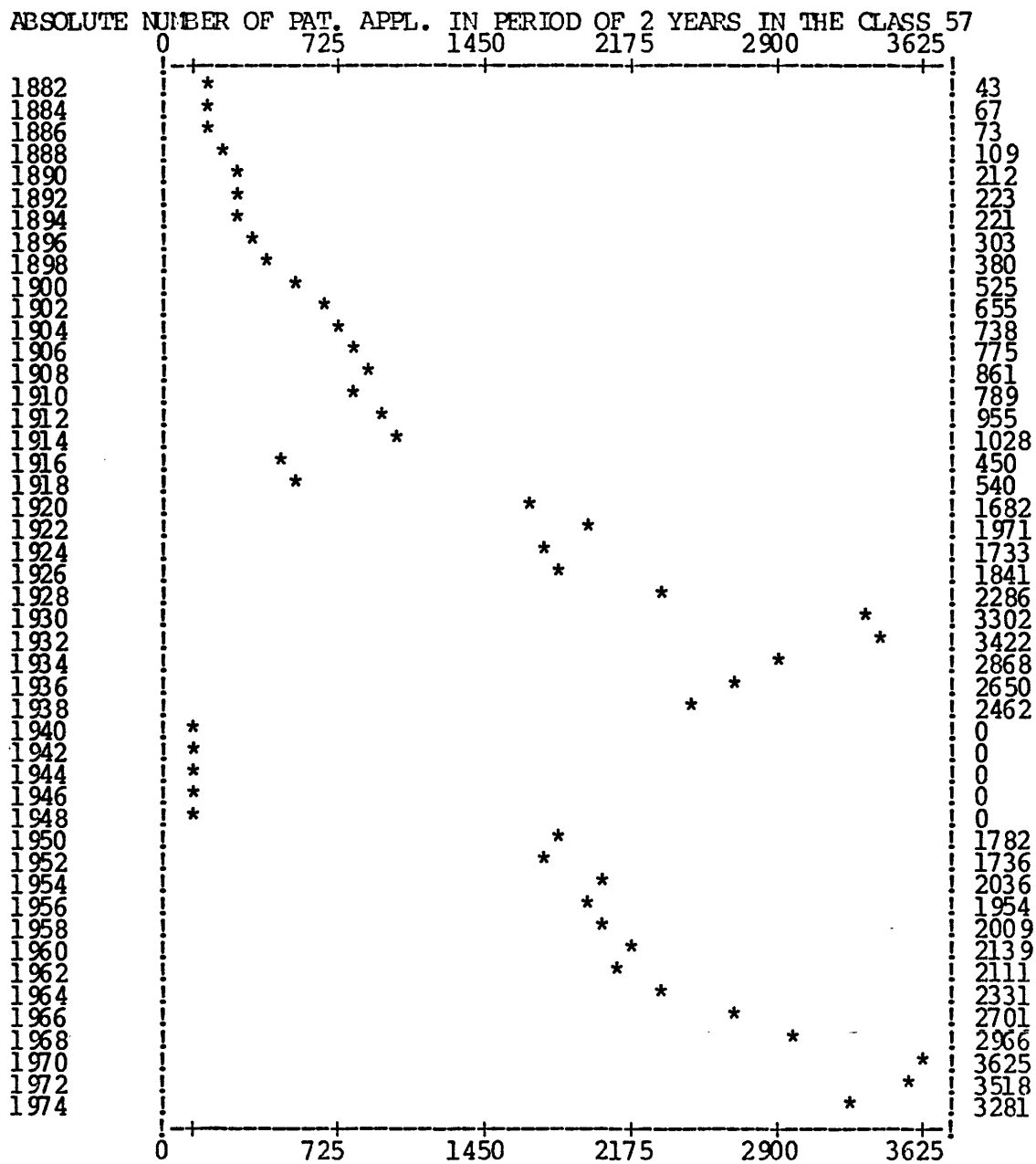

PROPORTION OF TOTAL PAT. APPL. IN 1/1000 IN THE CLASS 57

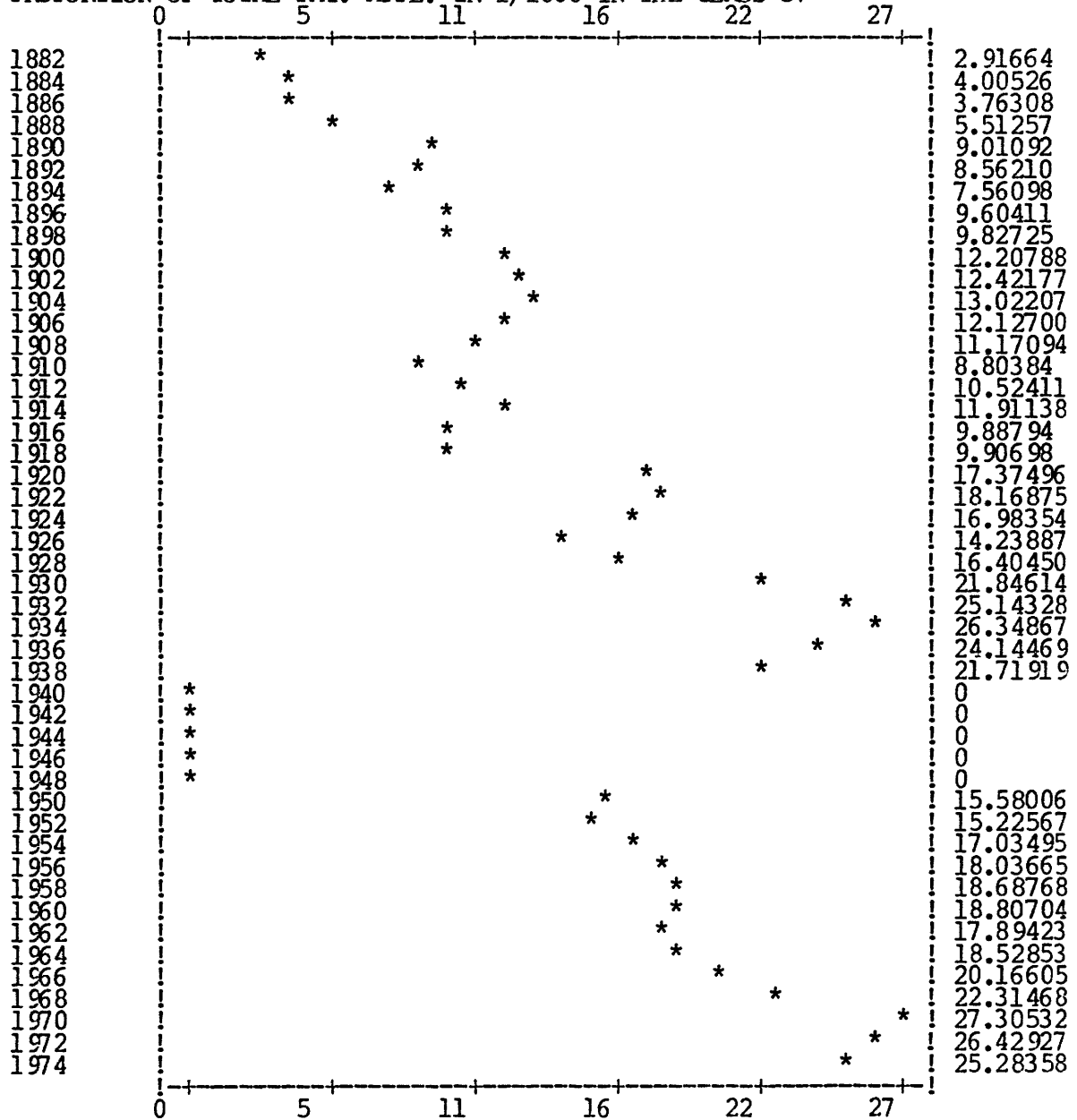

Cl. 58 Presses

ABSOLUTE NUMBER OF PAT. APPL. IN PERIOD OF 2 YEARS IN THE CLASS 58

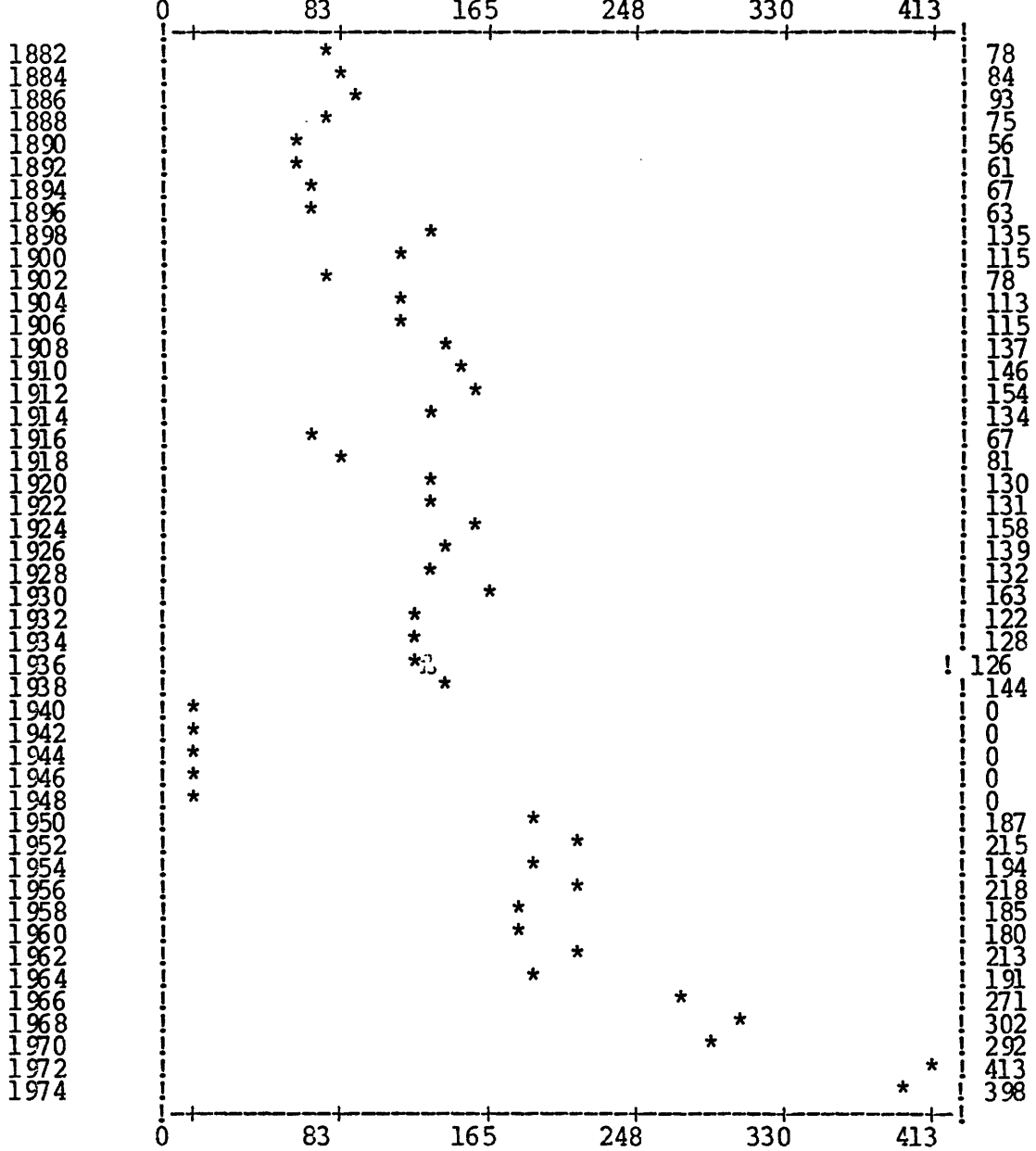

PROPORTION OF TOTAL PAT. APPL. IN 1/1000 IN THE CLASS 58

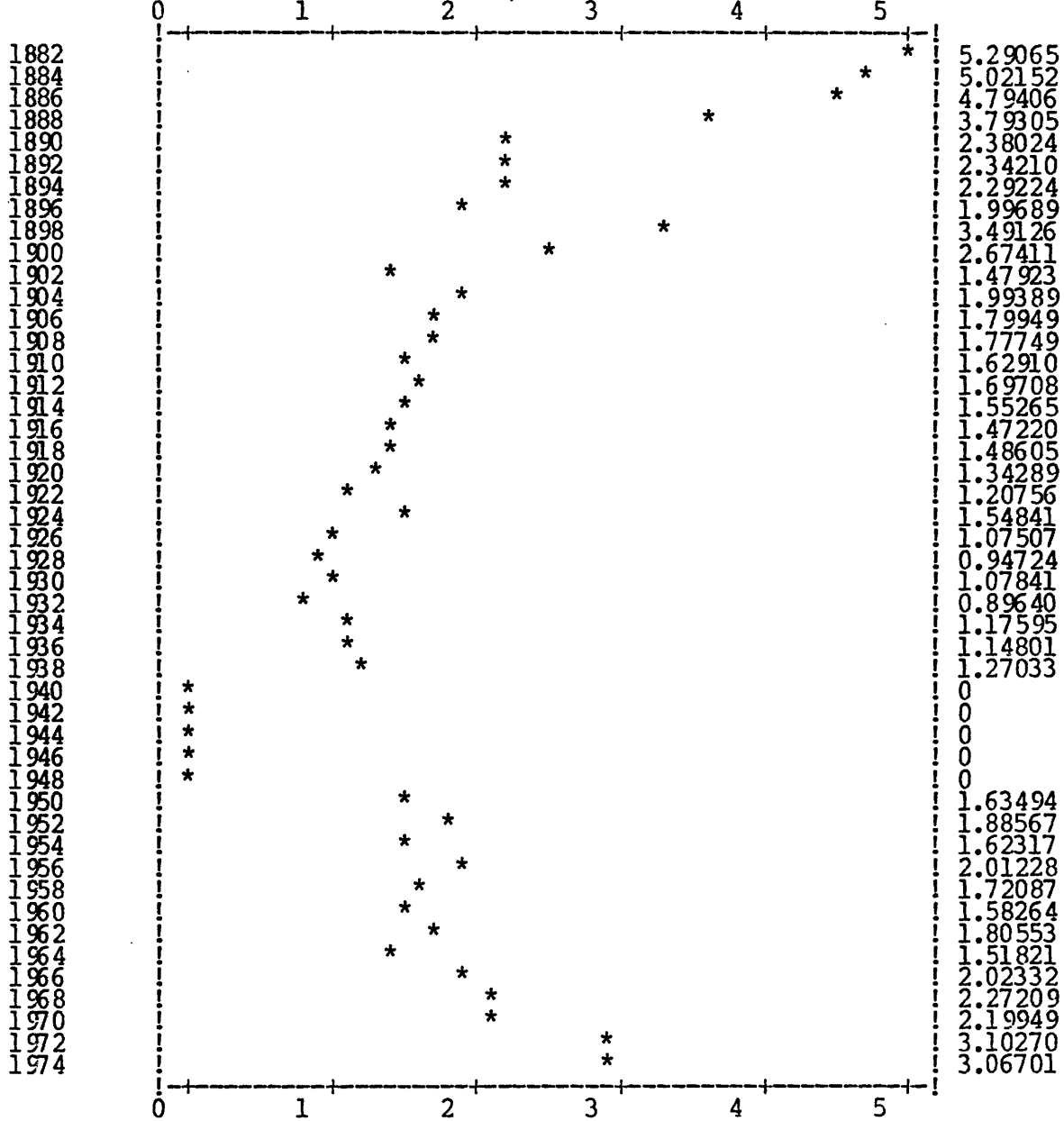



Cl. 59 Fluid pumps and other hydraulic lifting devices

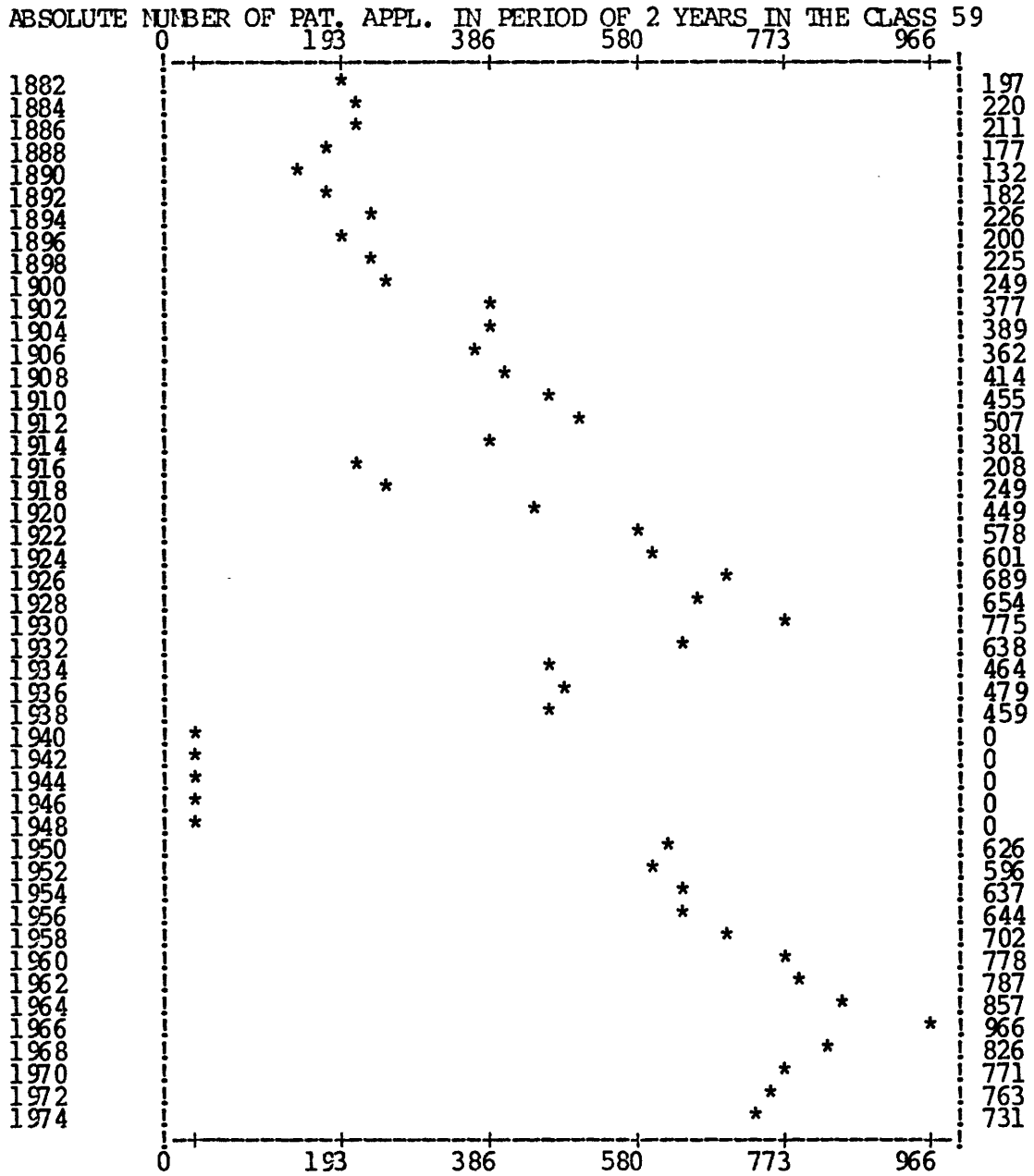

PROPORTION OF TOTAL PAT. APPL. IN 1/1000 IN THE CLASS 59

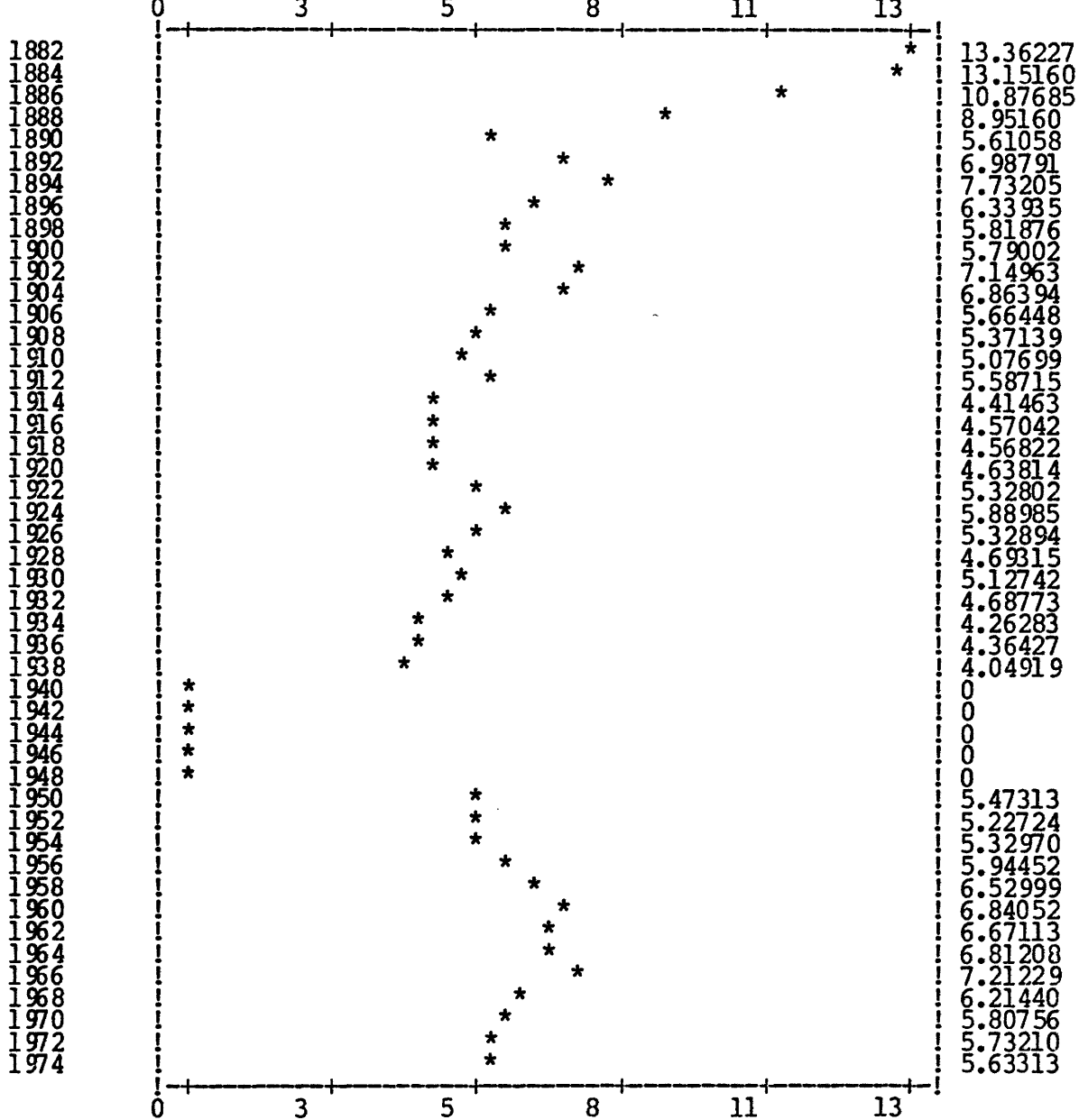

C1. 60 Fluid-pressure actuators; hydraulics and pneumatics in general

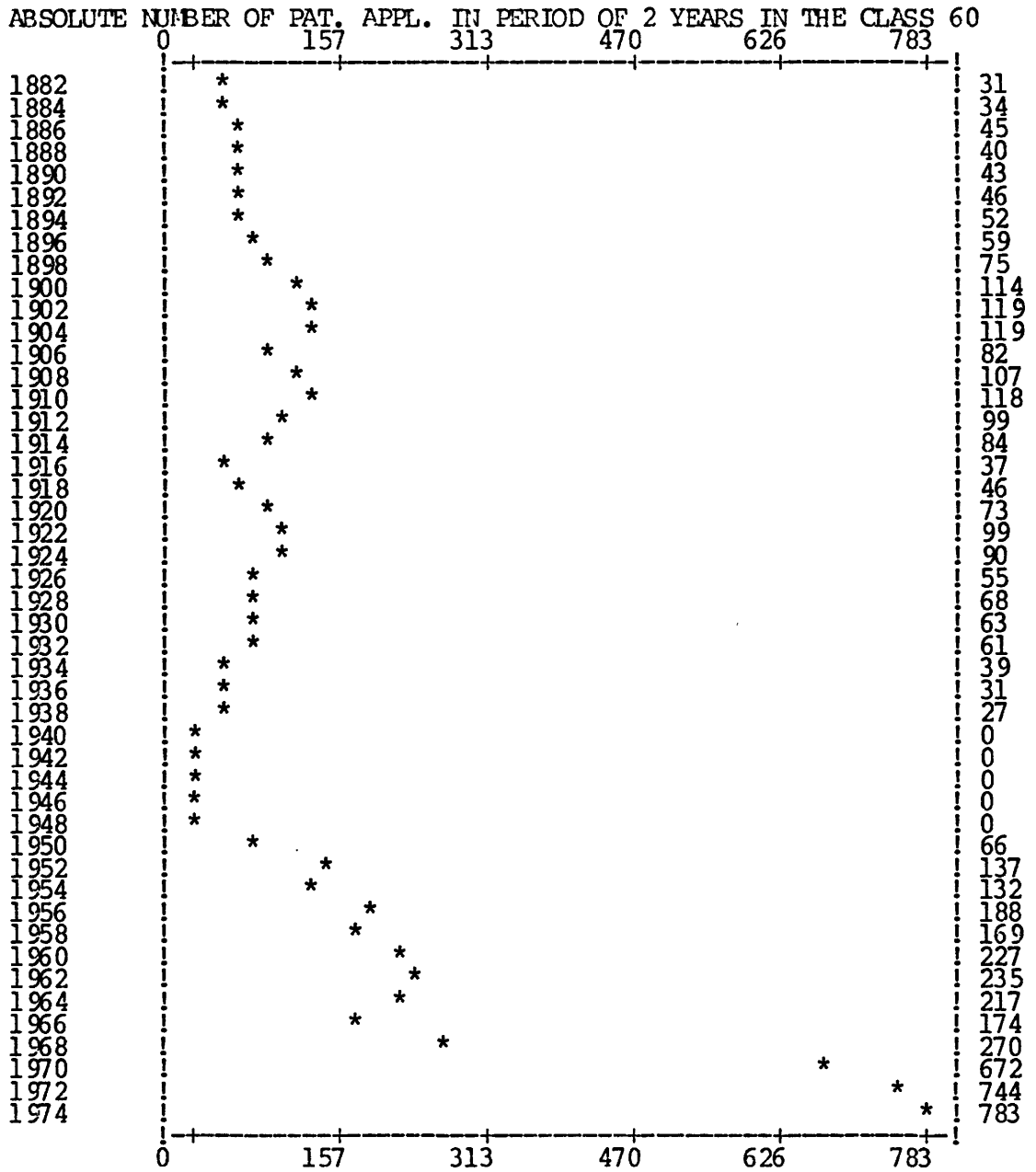

PROPORTION OF TOTAL PAT. APPL. IN 1/1000 IN THE CLASS 60

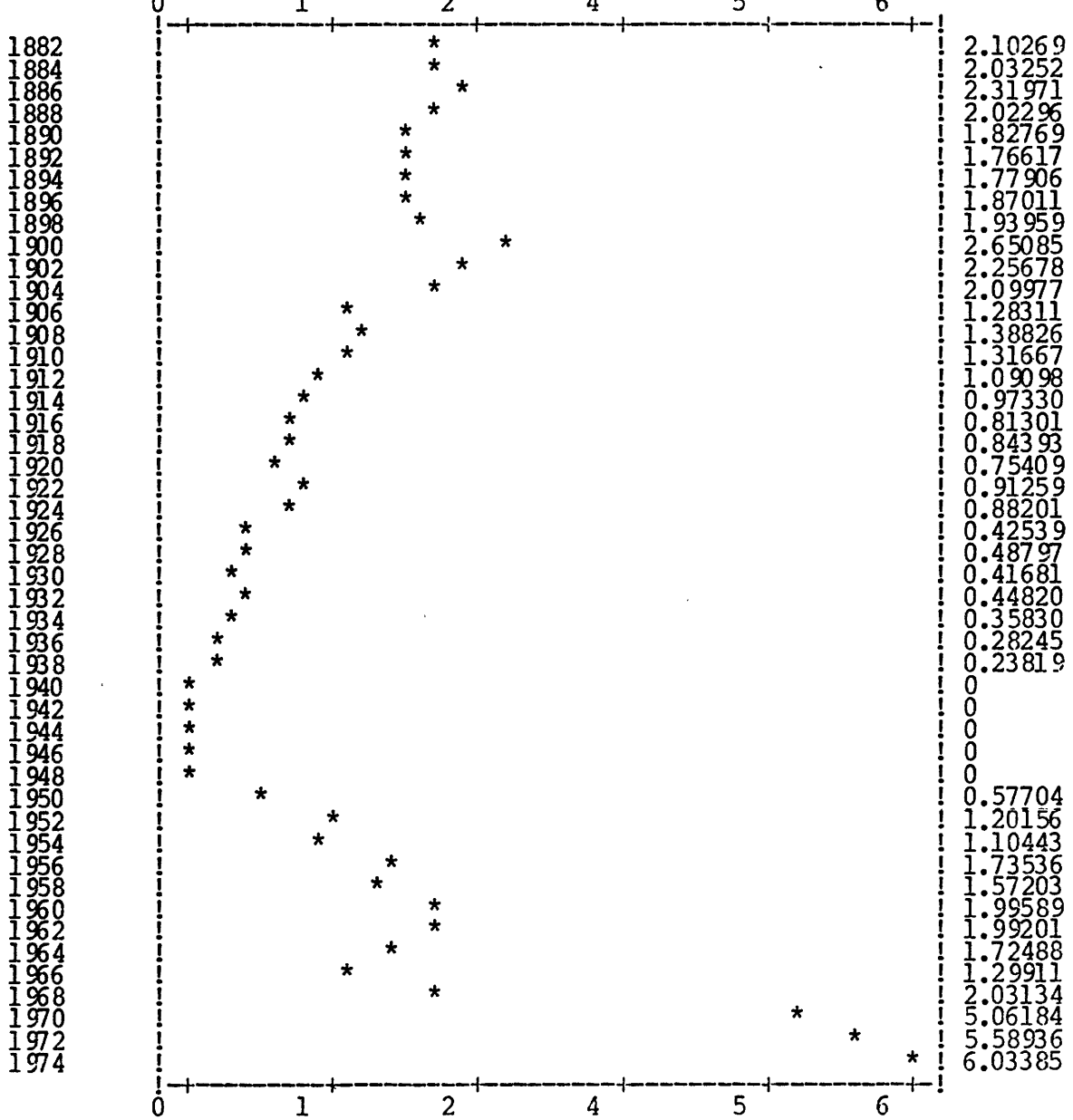

Cl. 61 Life-saving and fire-fighting

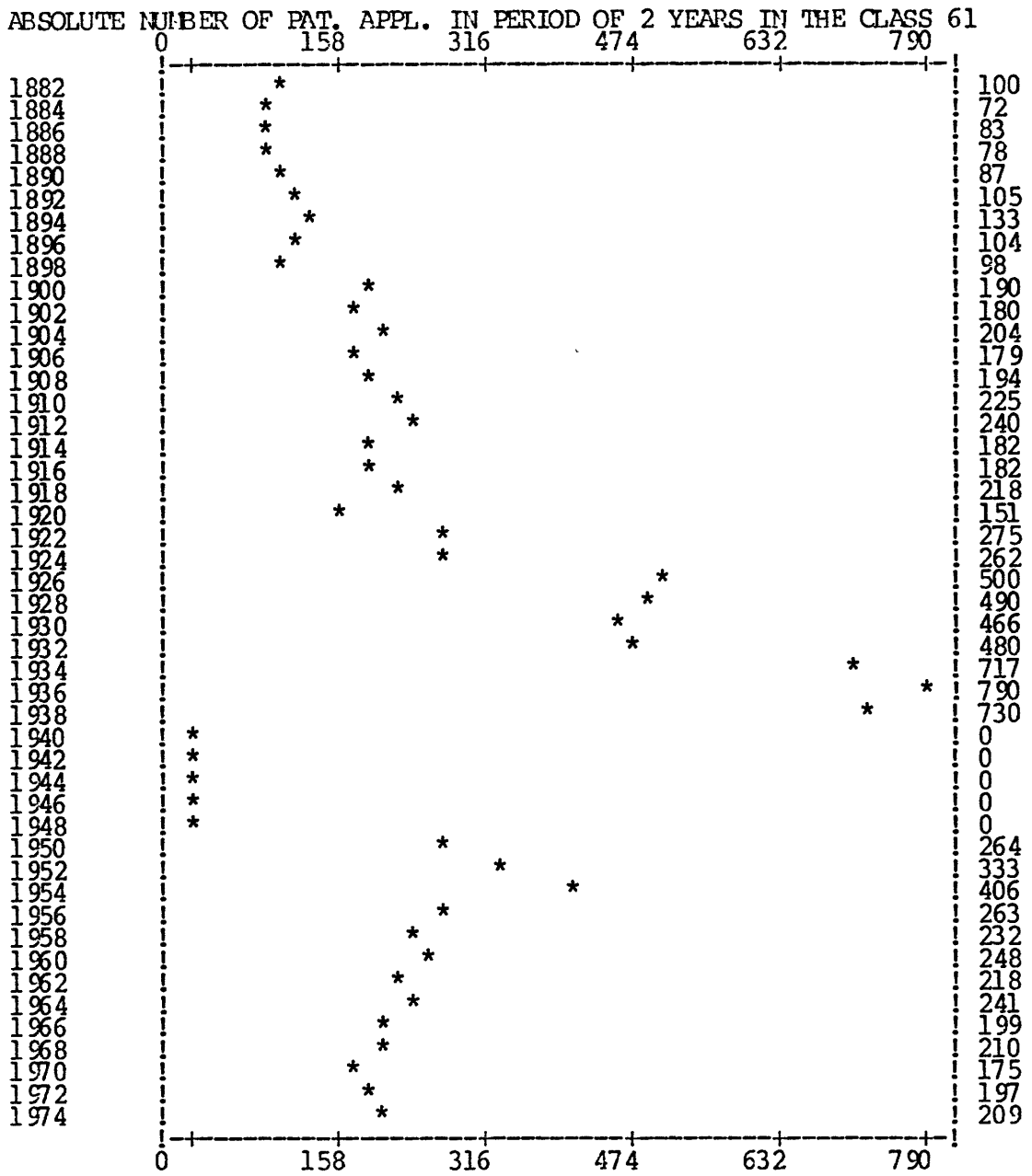

PROPORTION OF TOTAL PAT. APPL. IN 1/1000 IN THE CLASS 61

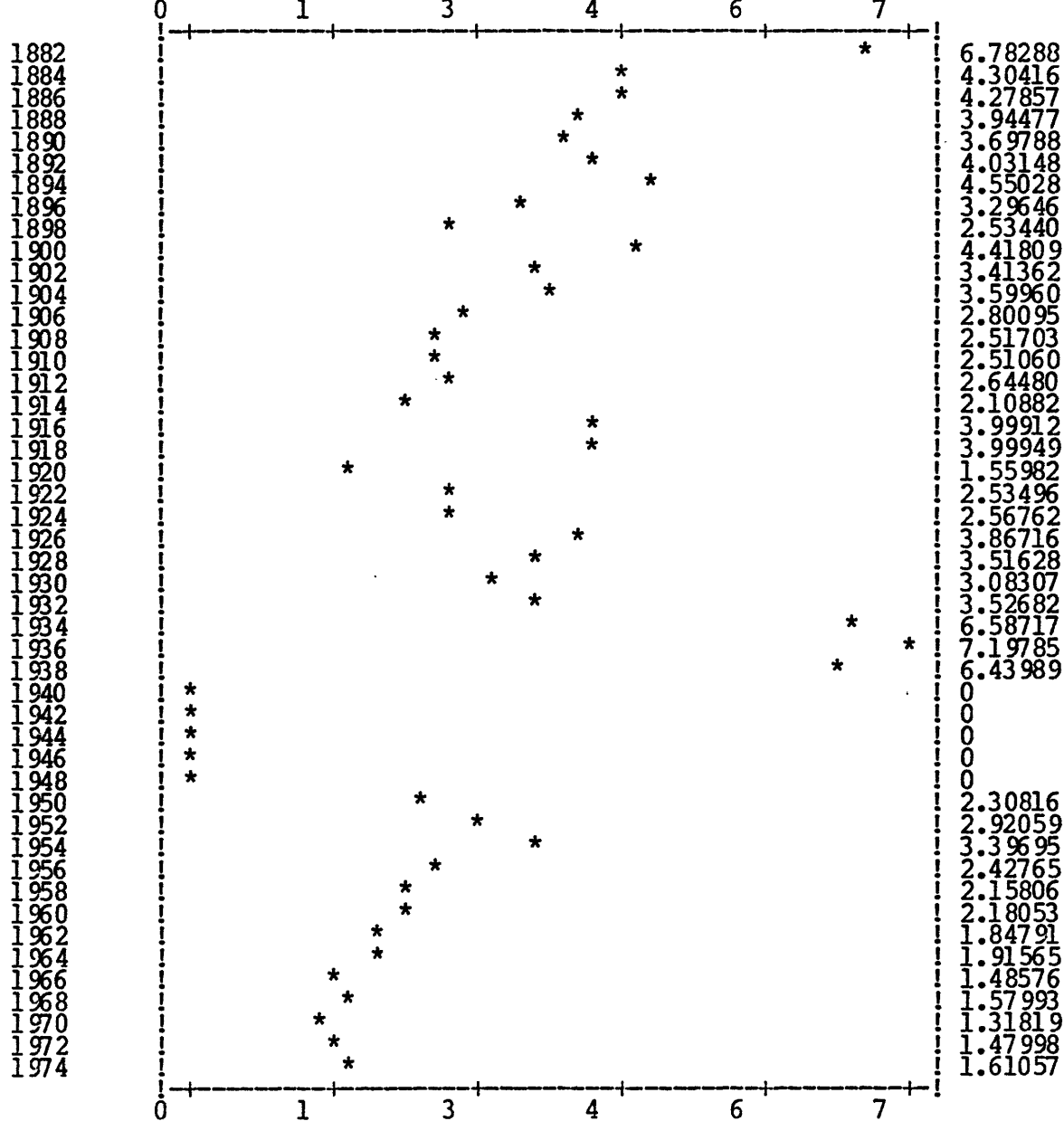

Cl. 62 Aviation, air cushion vehicles, cosmonautics

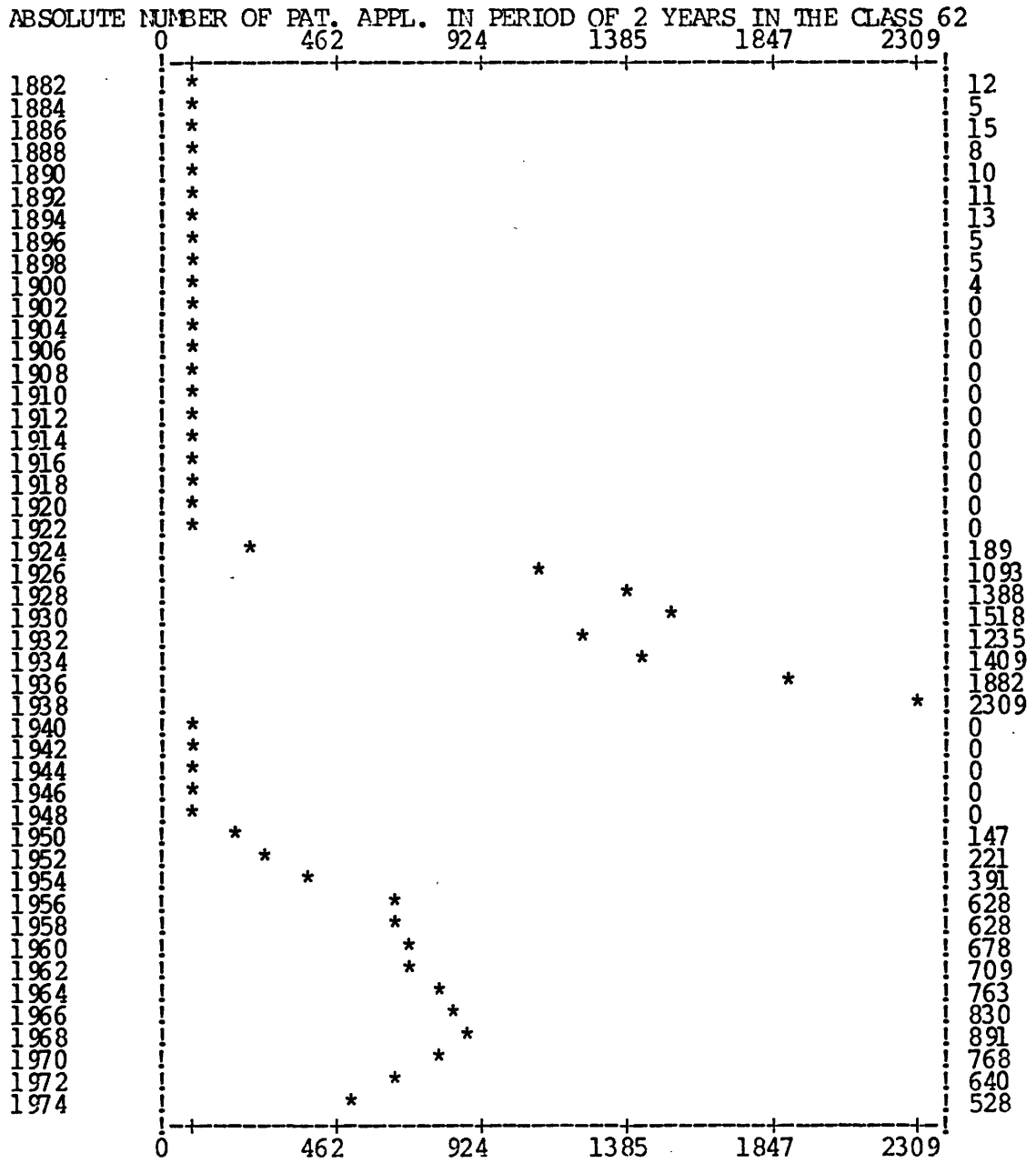

PROPORTION OF TOTAL PAT. APPL. IN 1/1000 IN THE CLASS 62

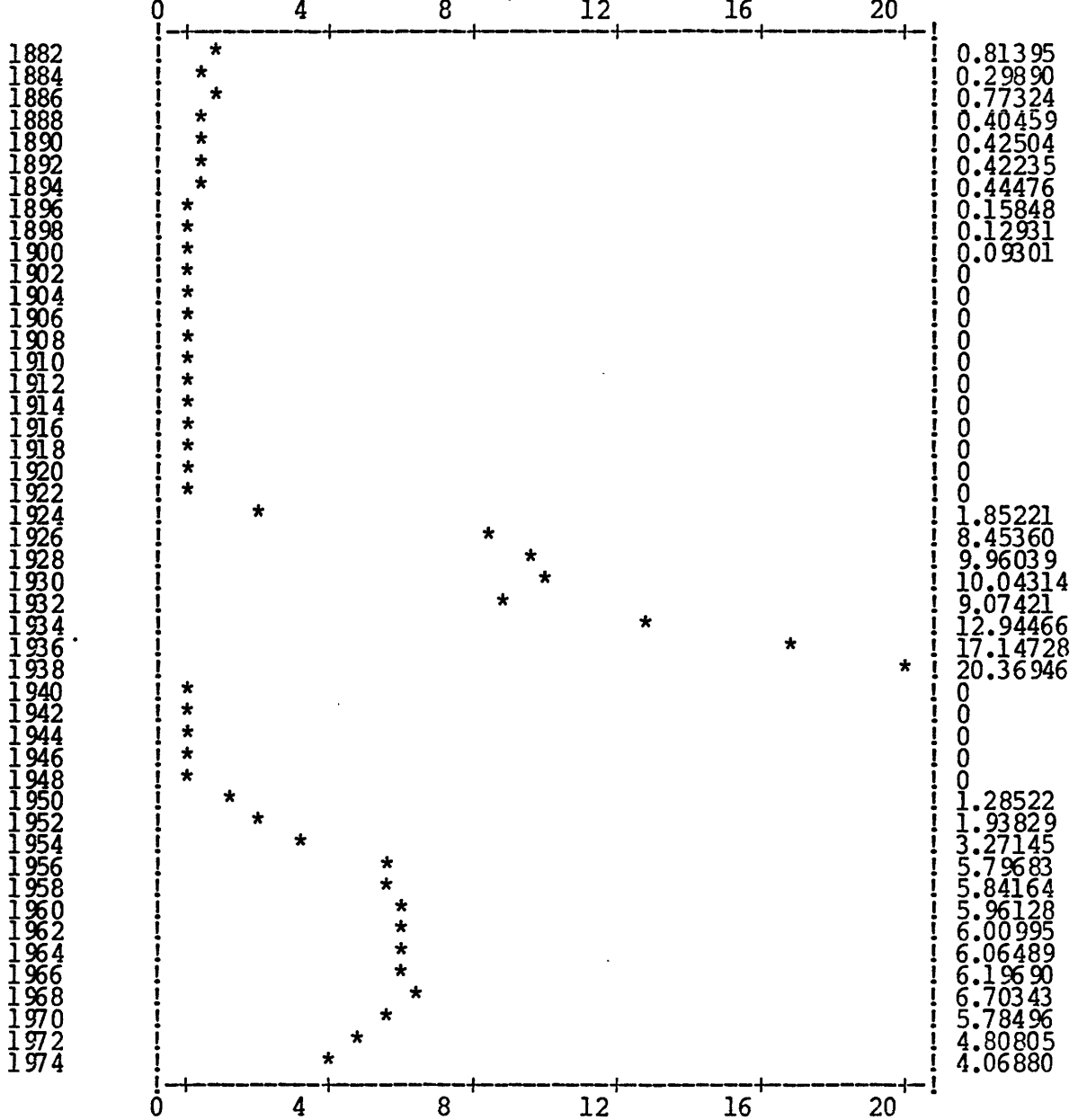



Cl. 63 Trackless vehicles

ABSOLUTE NUMBER OF PAT. APPL. IN PERIOD OF 2 YEARS IN THE CLASS 63

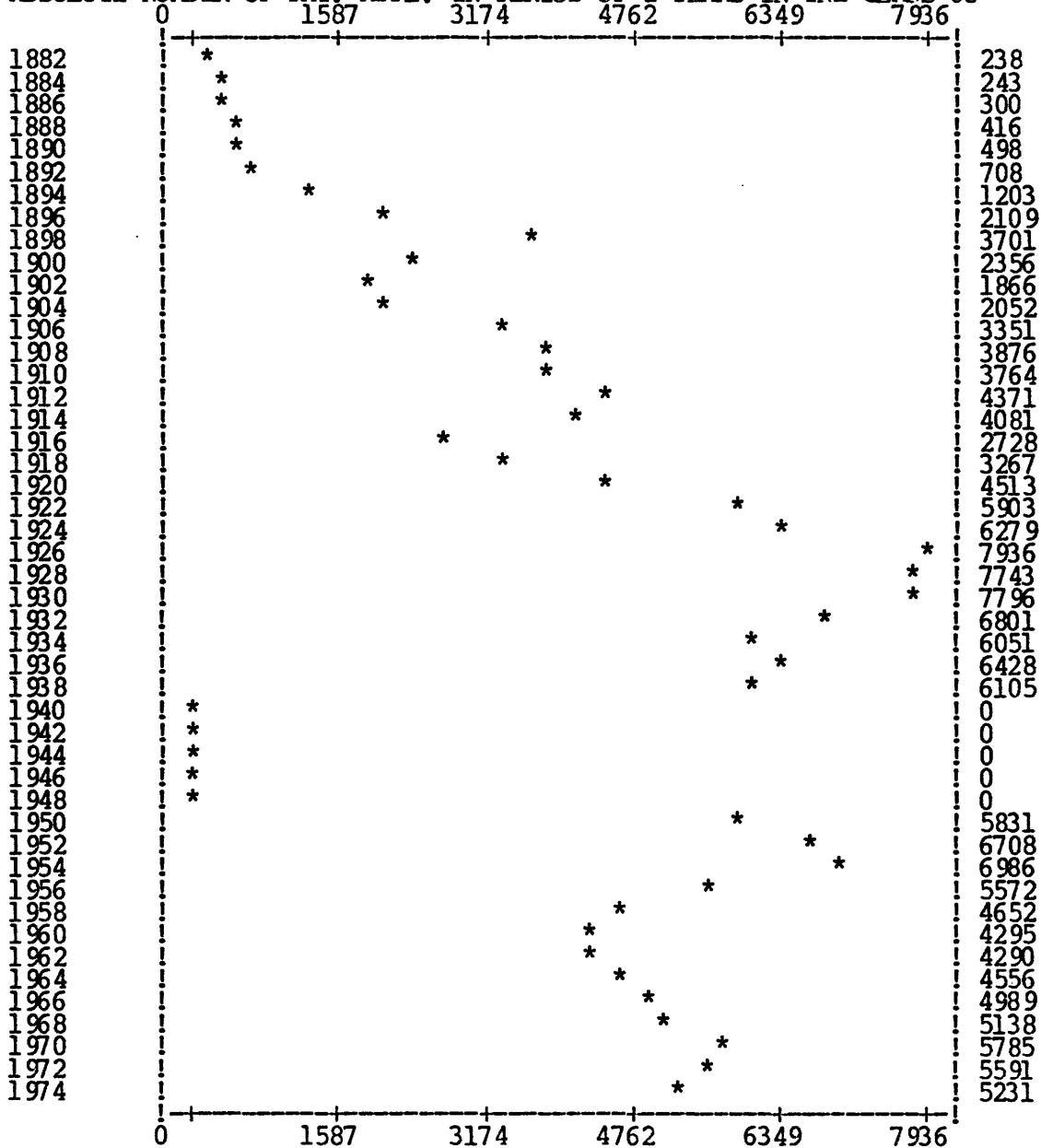

PROPORTION OF TOTAL PAT. APPL. IN 1/1000 IN THE CLASS 63

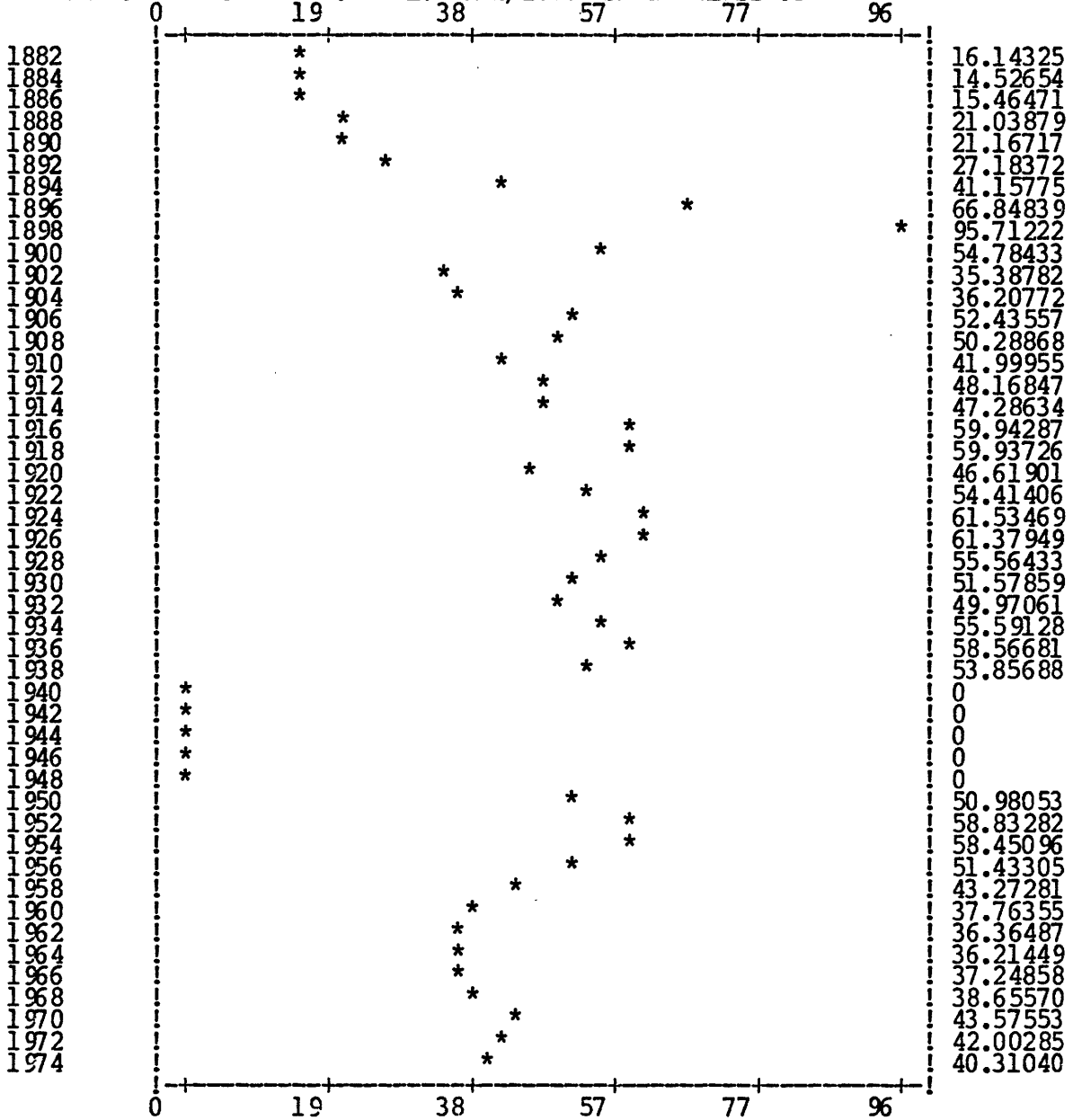

Cl. 64 Distribution of alcoholic liquors

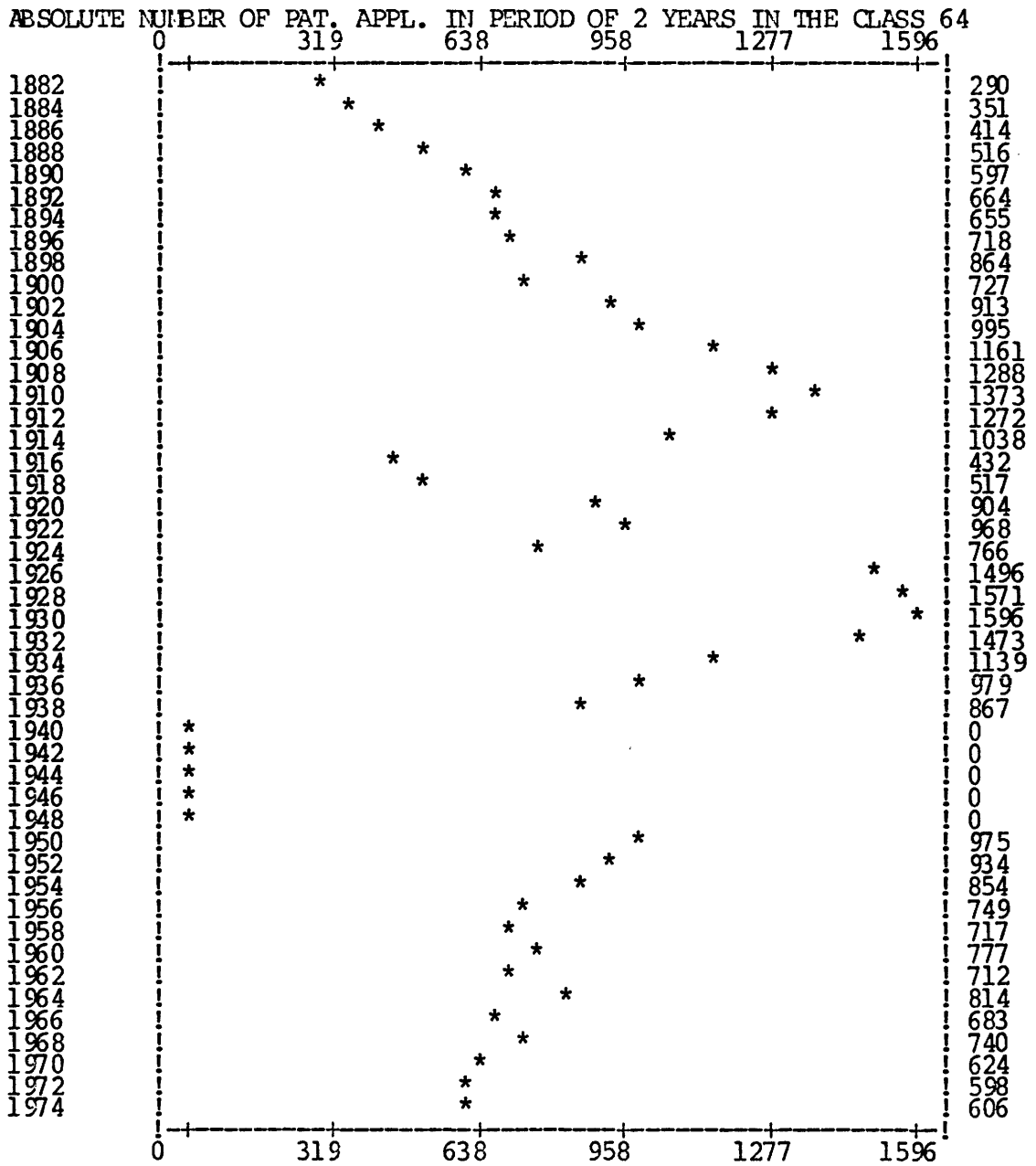

PROPORTION OF TOTAL PAT. APPL. IN 1/1000 IN THE CLASS 64

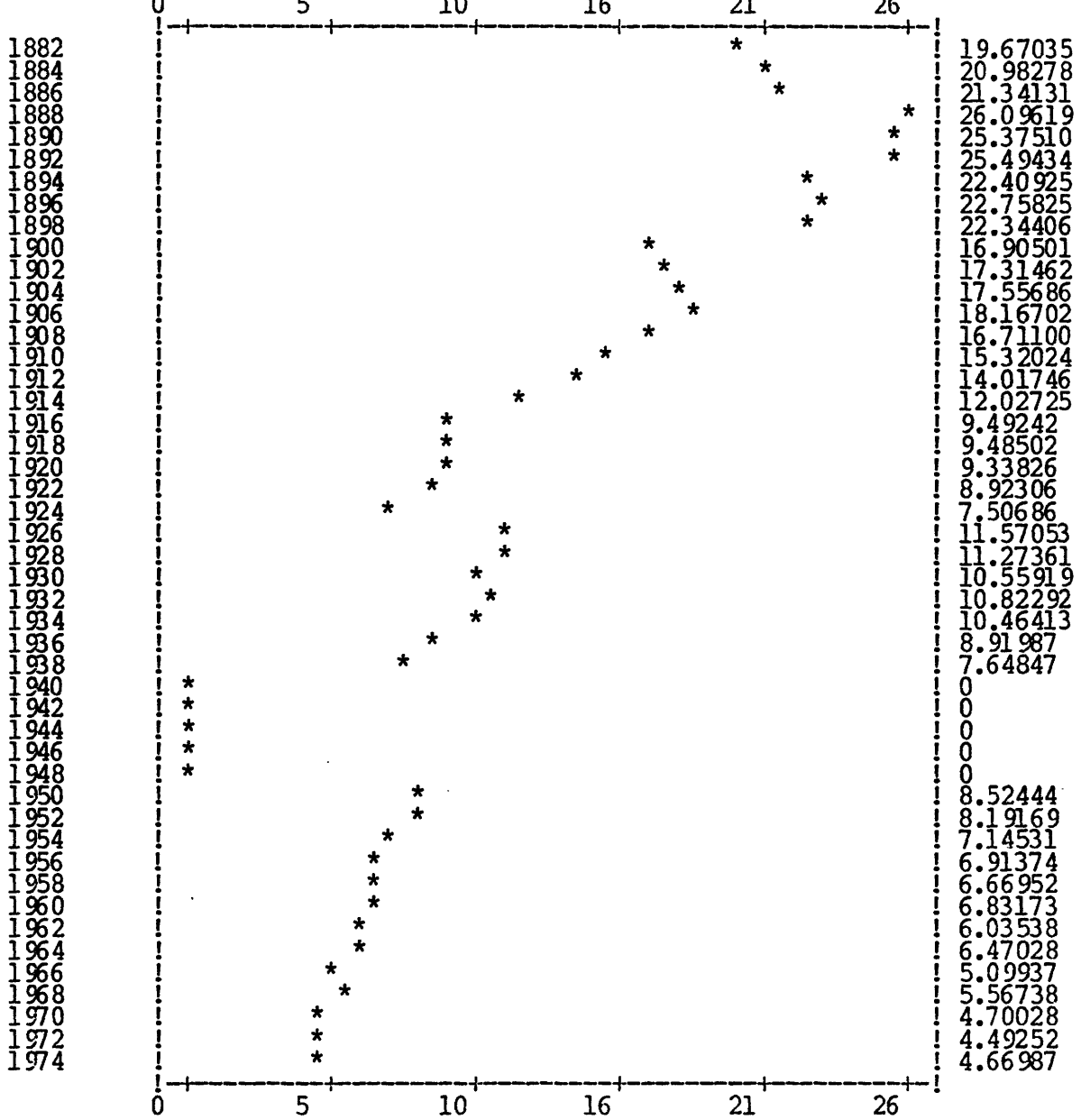

Cl. 65 Ships and other waterborne vehicles; related equipment

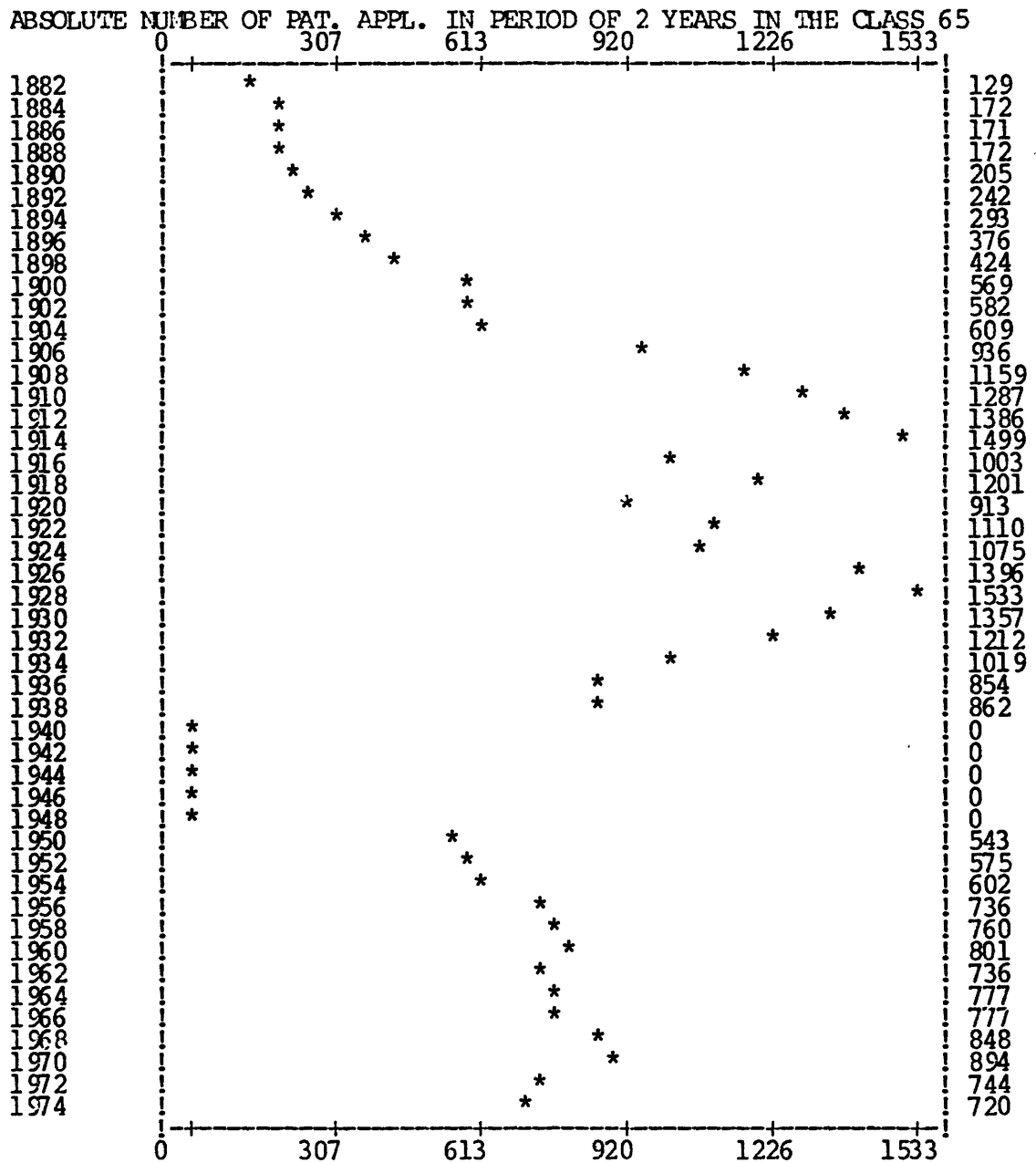

GEORG CRESPEL IN FRANKFURT A. M.

Trocken-Apparat.

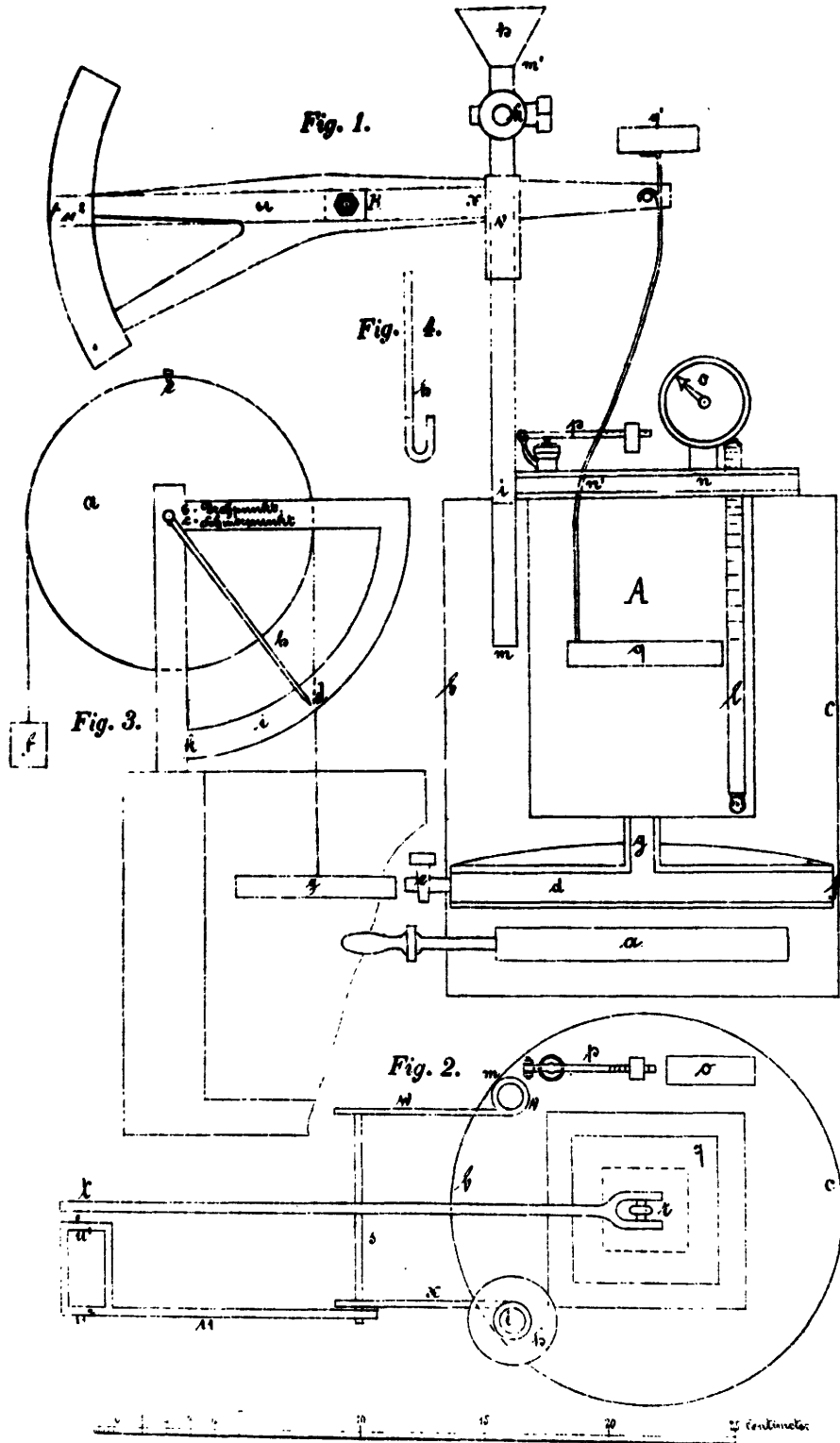

Zu der Patentschrift

№ 76.

PHOTOG. DRUCK DER KÖNIGL. PREUSS. STAATSDRUCKEREI.

A. LANGE & SÖHNE IN GLASHÜTTE (SACHSEN).  
Secundenwerk mit springendem Zeiger.

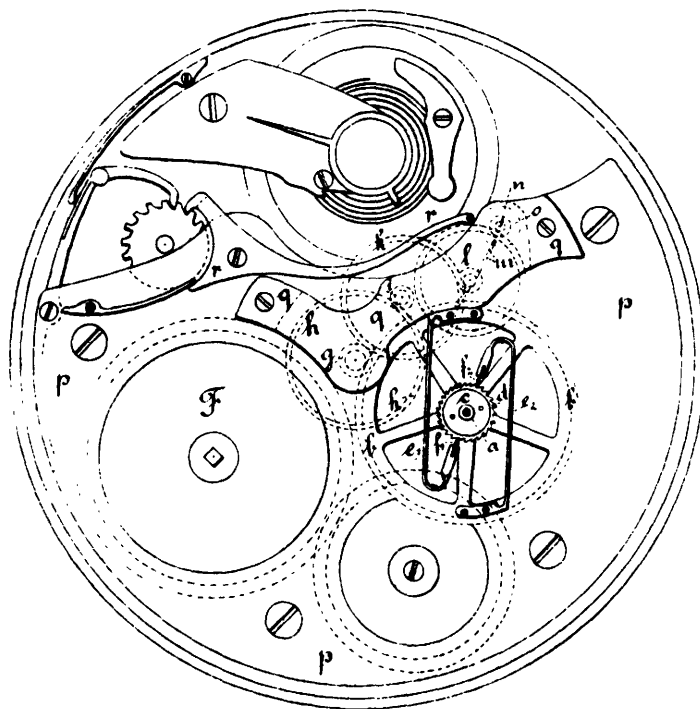

Zu der Patentschrift

**№ 182.**

PHOTOGR. DRUCK DER KÖNIGL. PREUSS. STAATSDRUCKEREI.

PROPORTION OF TOTAL PAT. APPL. IN 1/1000 IN THE CLASS 65

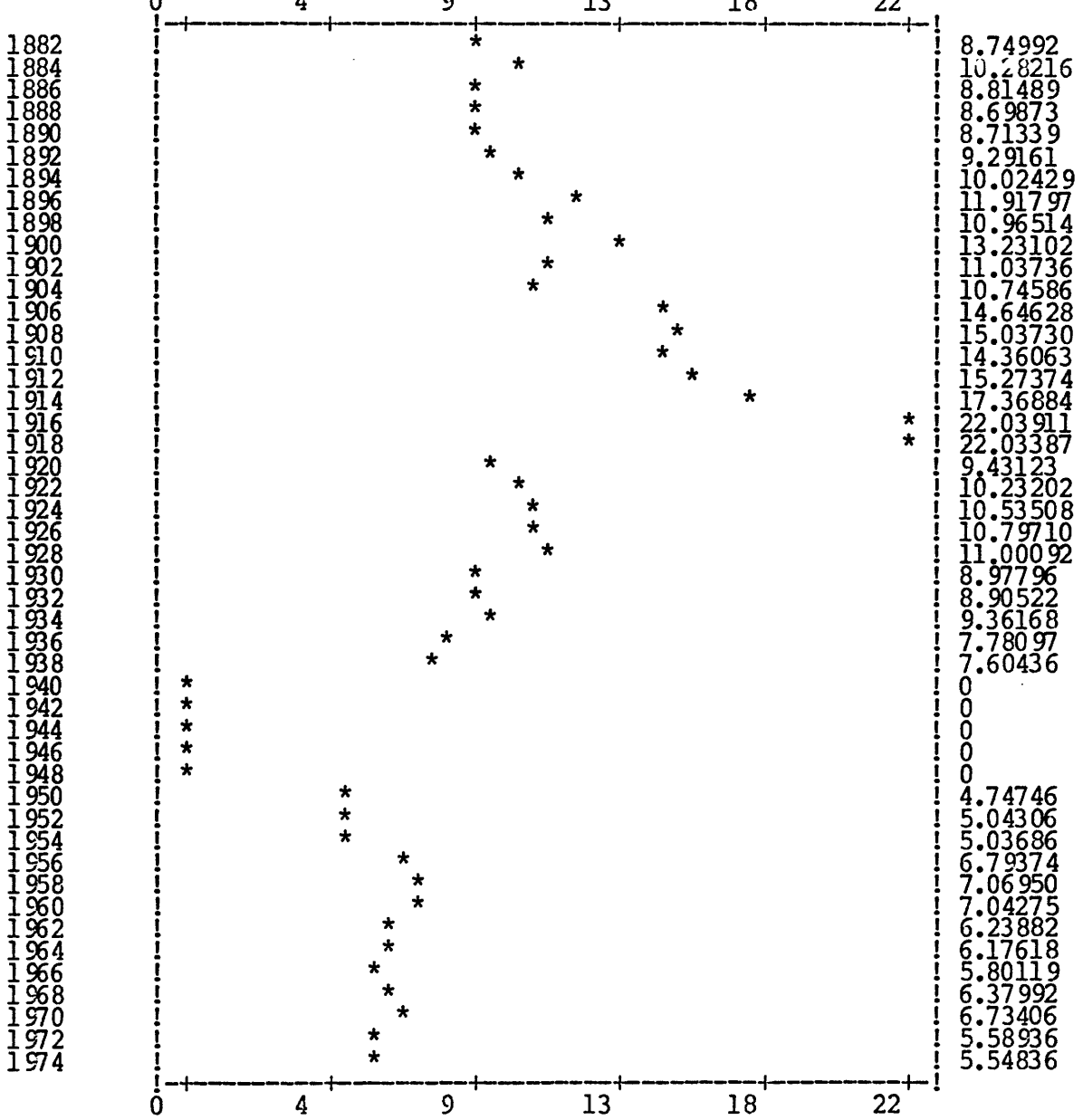



Cl. 66 Butchering and meat treatment

ABSOLUTE NUMBER OF PAT. APPL. IN PERIOD OF 2 YEARS IN THE CLASS 66

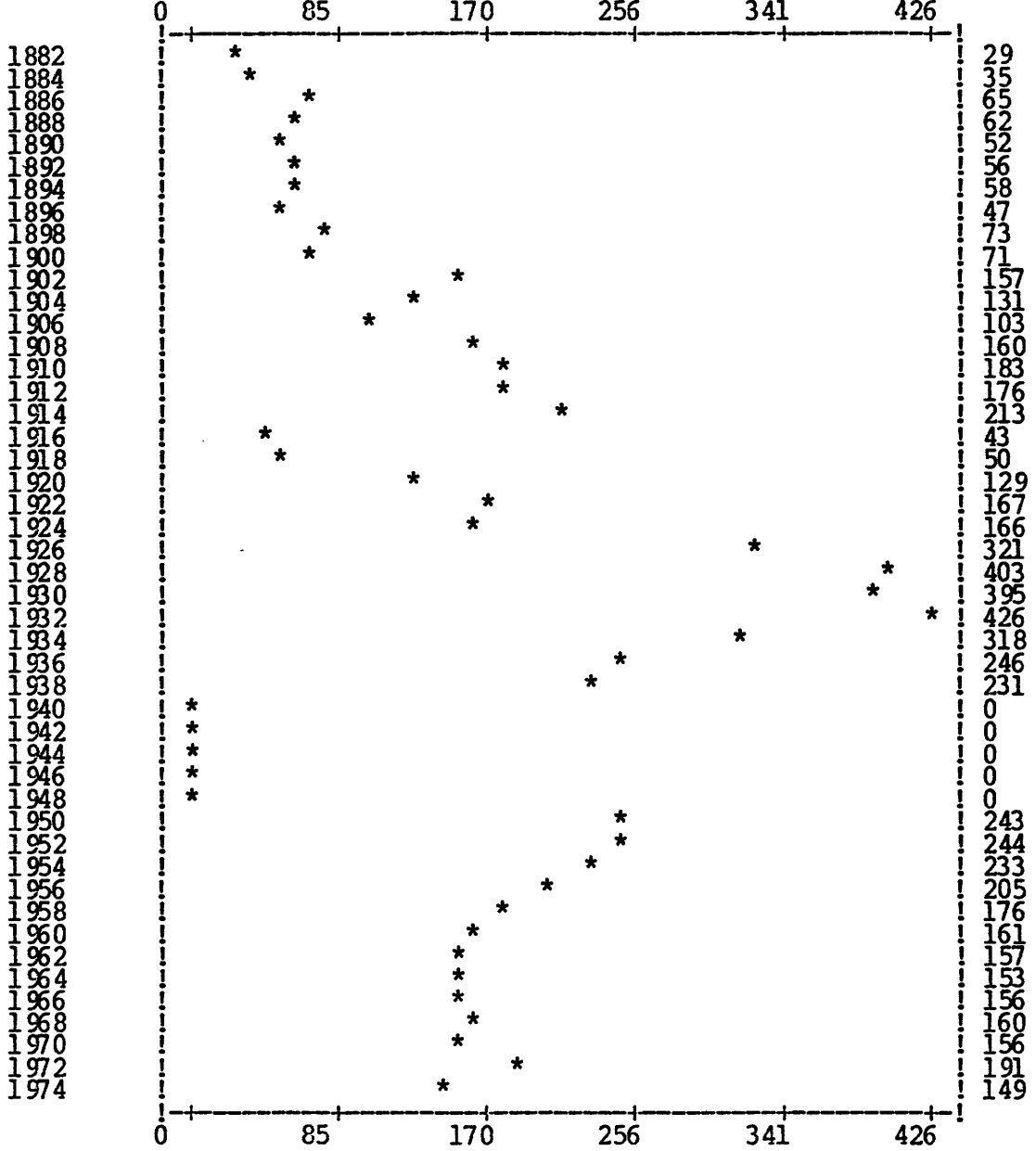

PROPORTION OF TOTAL PAT. APPL. IN 1/1000 IN THE CLASS 66

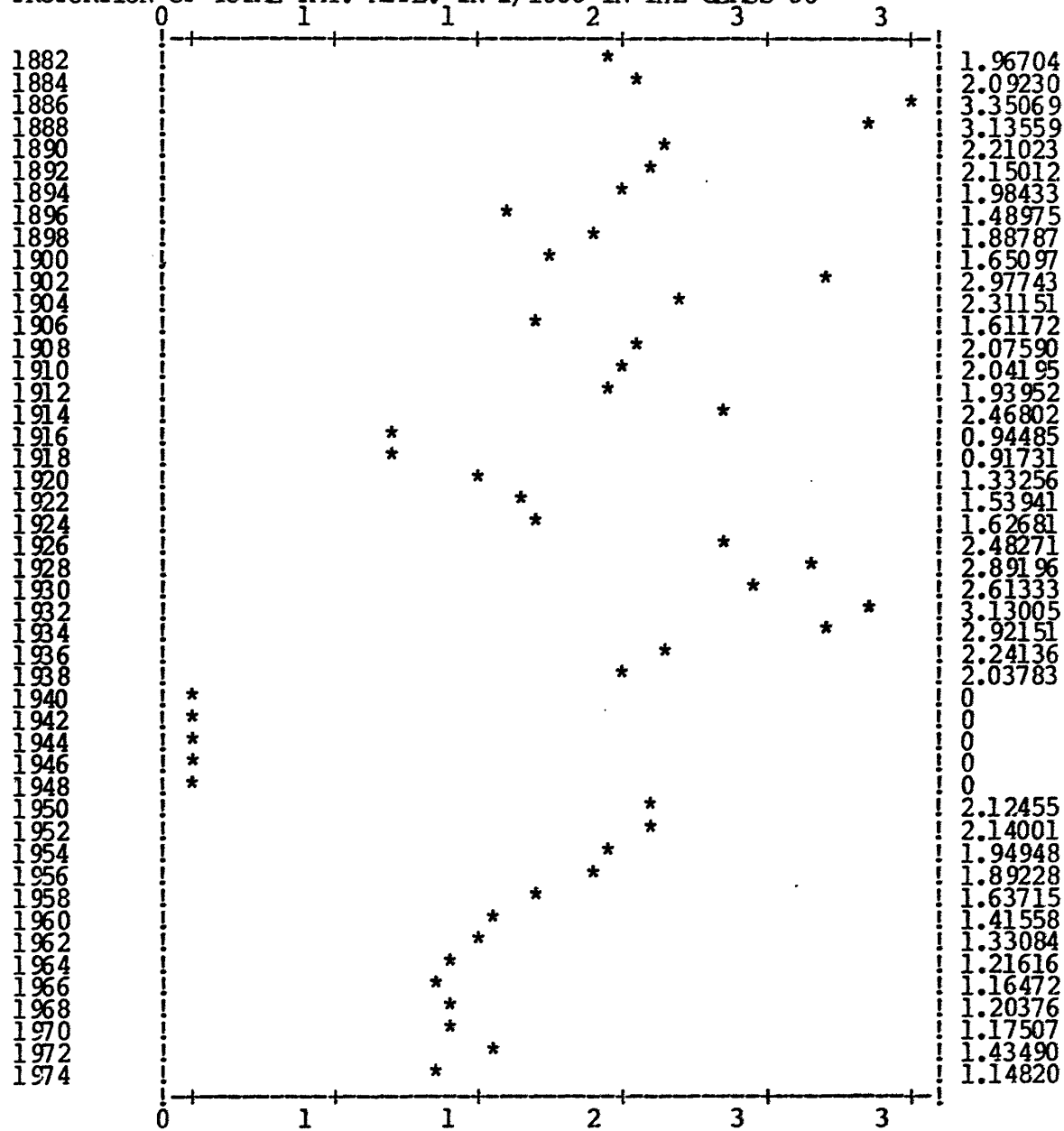

Cl. 67 Grinding and polishing

ABSOLUTE NUMBER OF PAT. APPL. IN PERIOD OF 2 YEARS IN THE CLASS 67

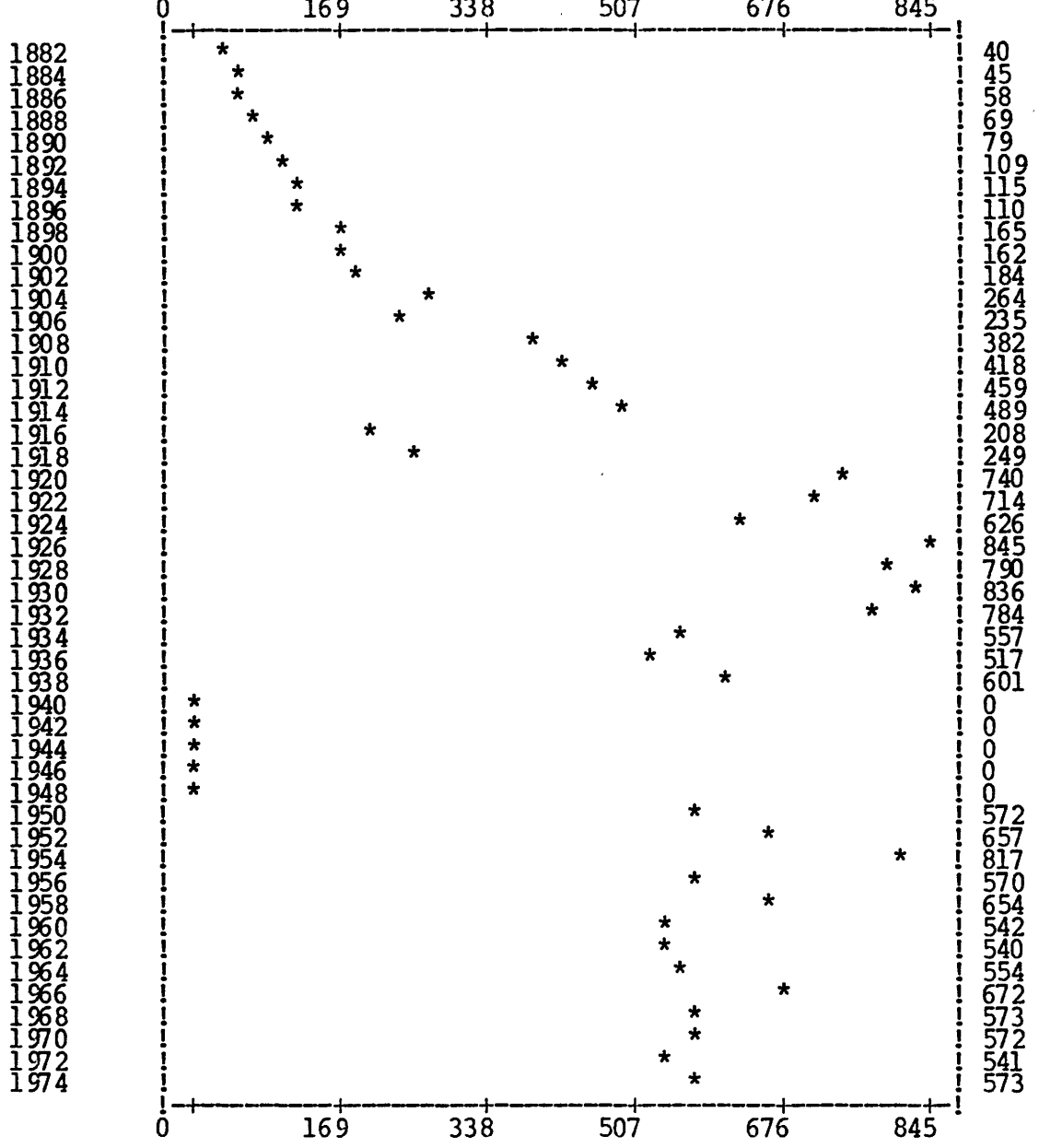

PROPORTION OF TOTAL PAT. APPL. IN 1/1000 IN THE CLASS 67

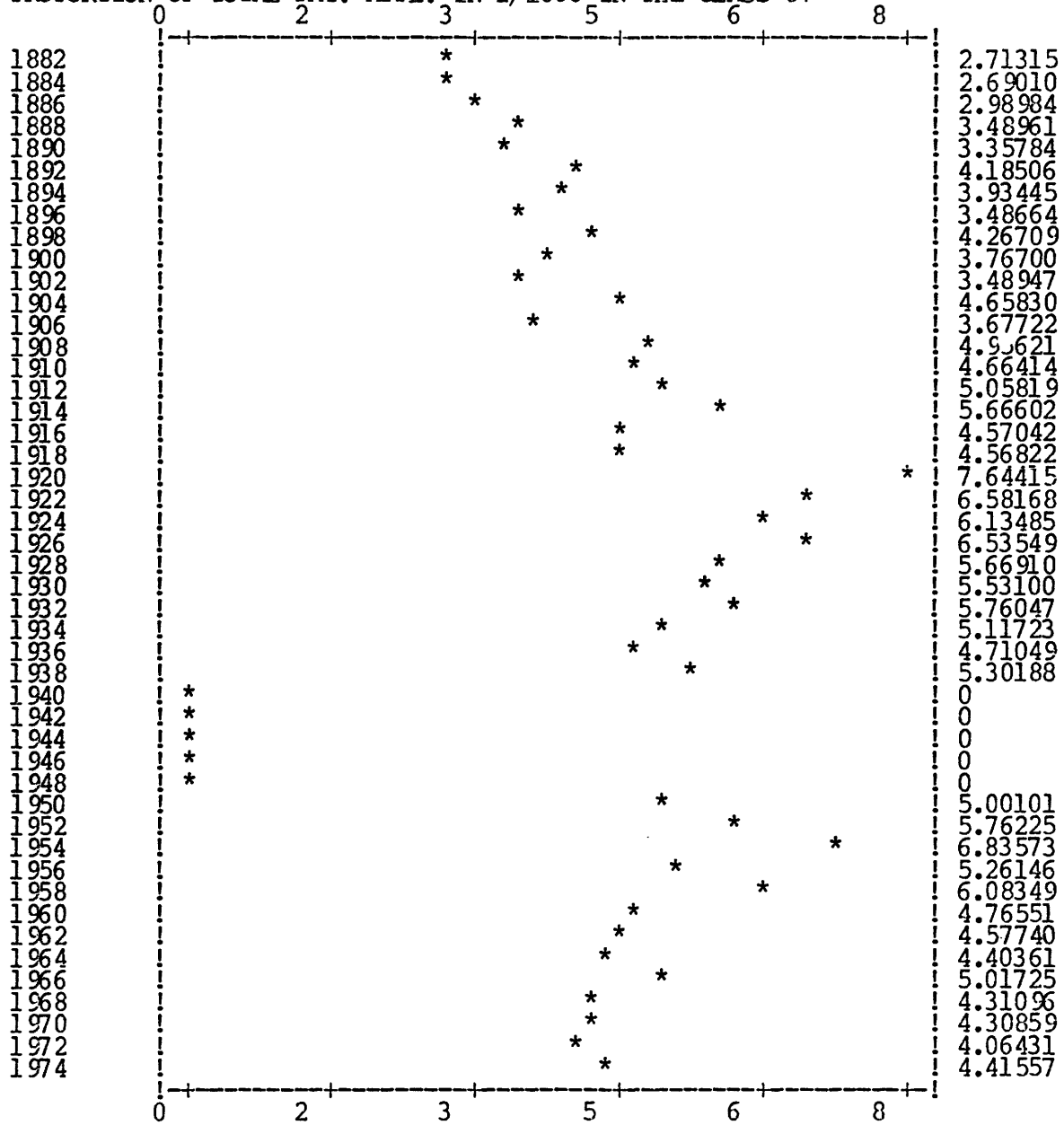

Cl. 68 Articles of the locksmithing trade

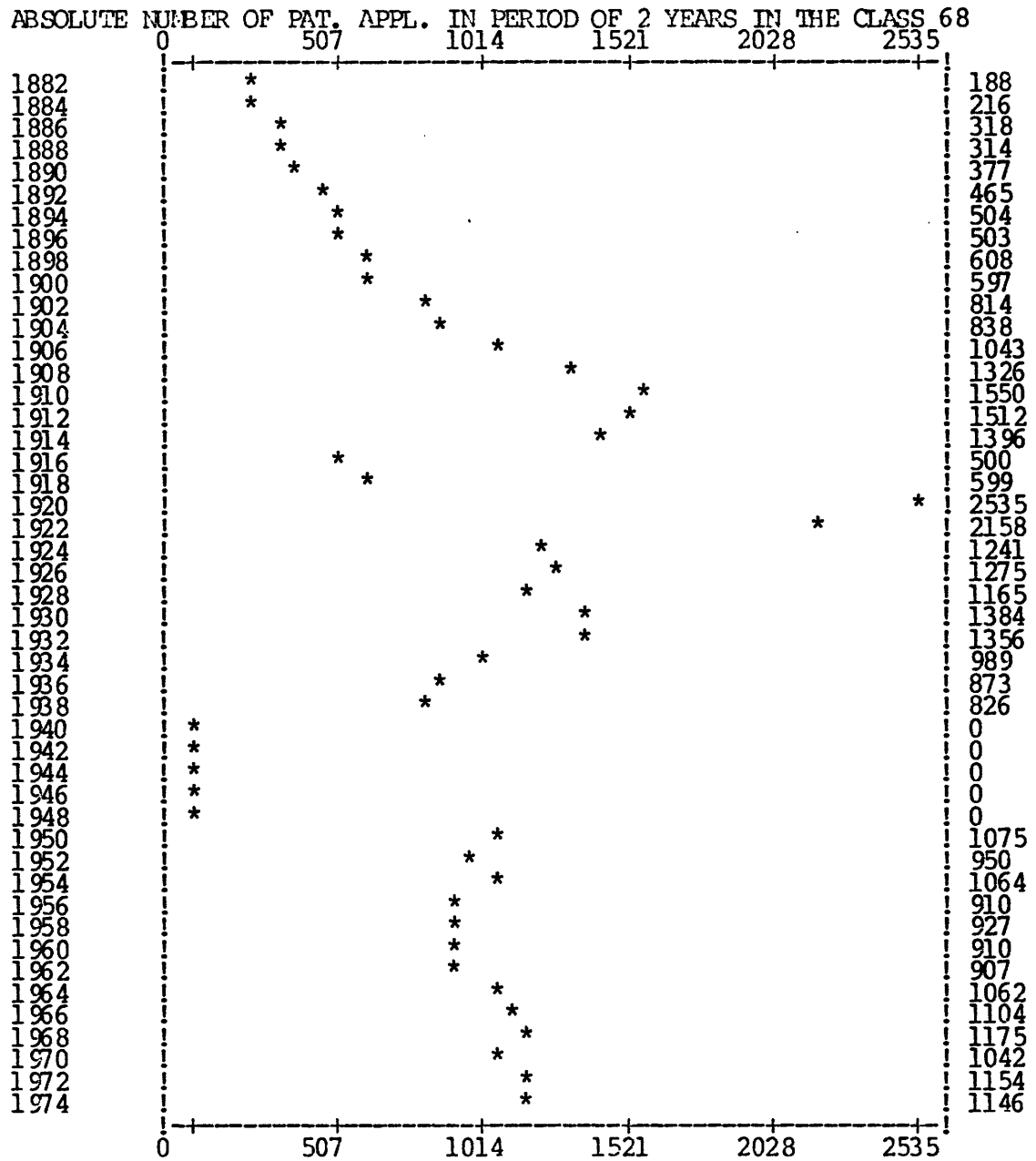

PROPORTION OF TOTAL PAT. APPL. IN 1/1000 IN THE CLASS 68

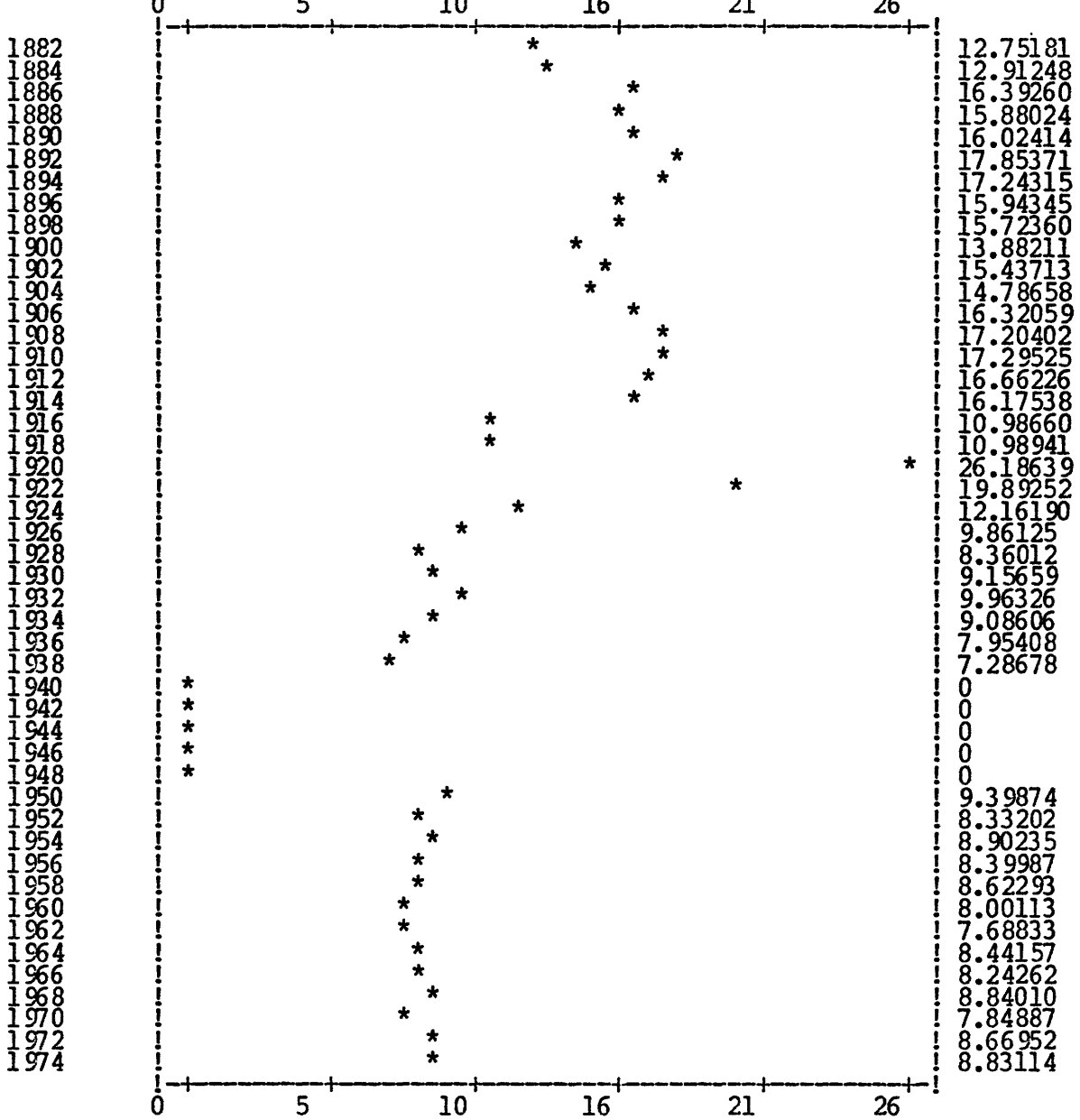

Cl. 69 Cutting tools including cutting and stabbing weapons; domestic cutting appliances and machines

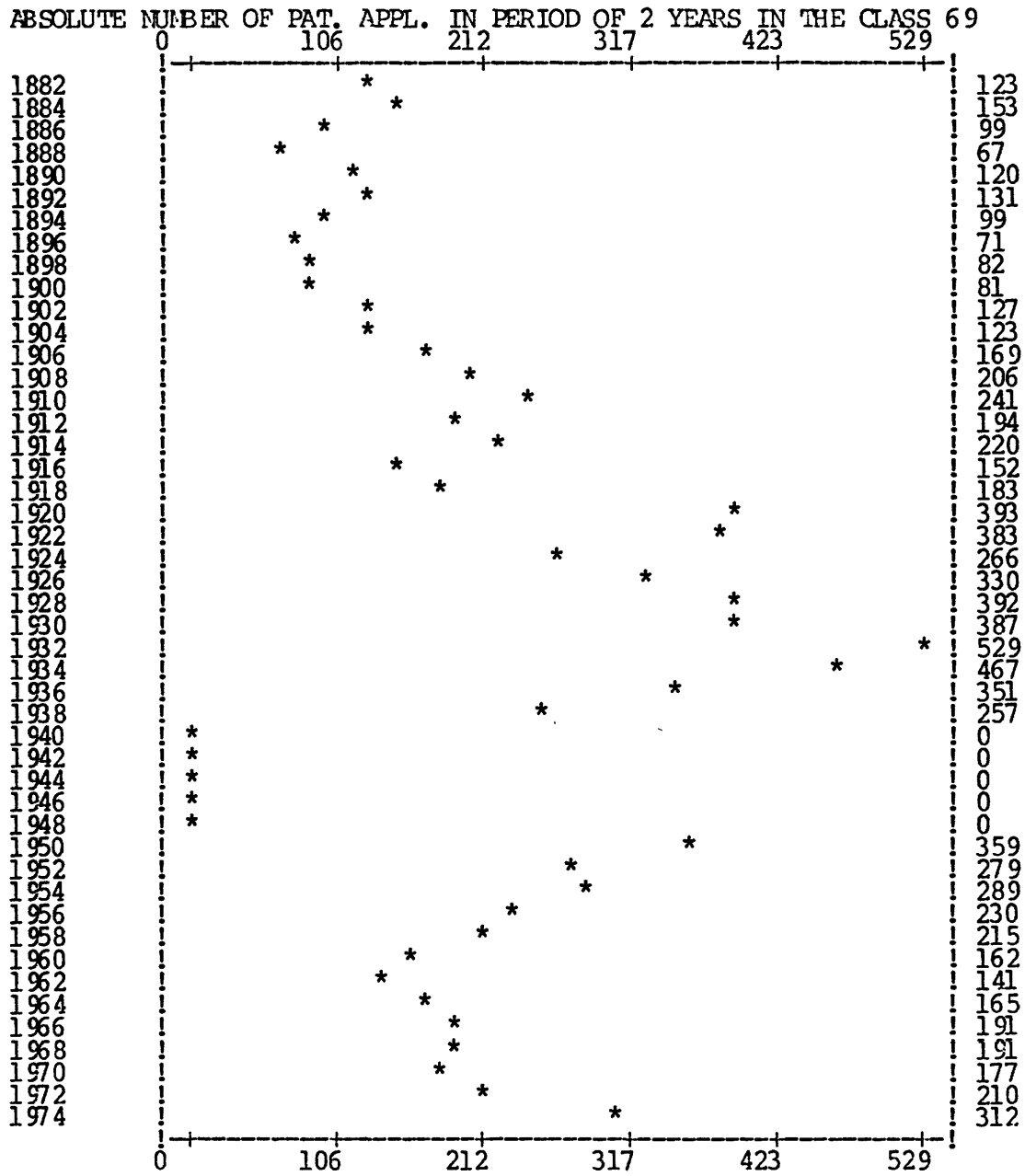

PROPORTION OF TOTAL PAT. APPL. IN 1/1000 IN THE CLASS 69

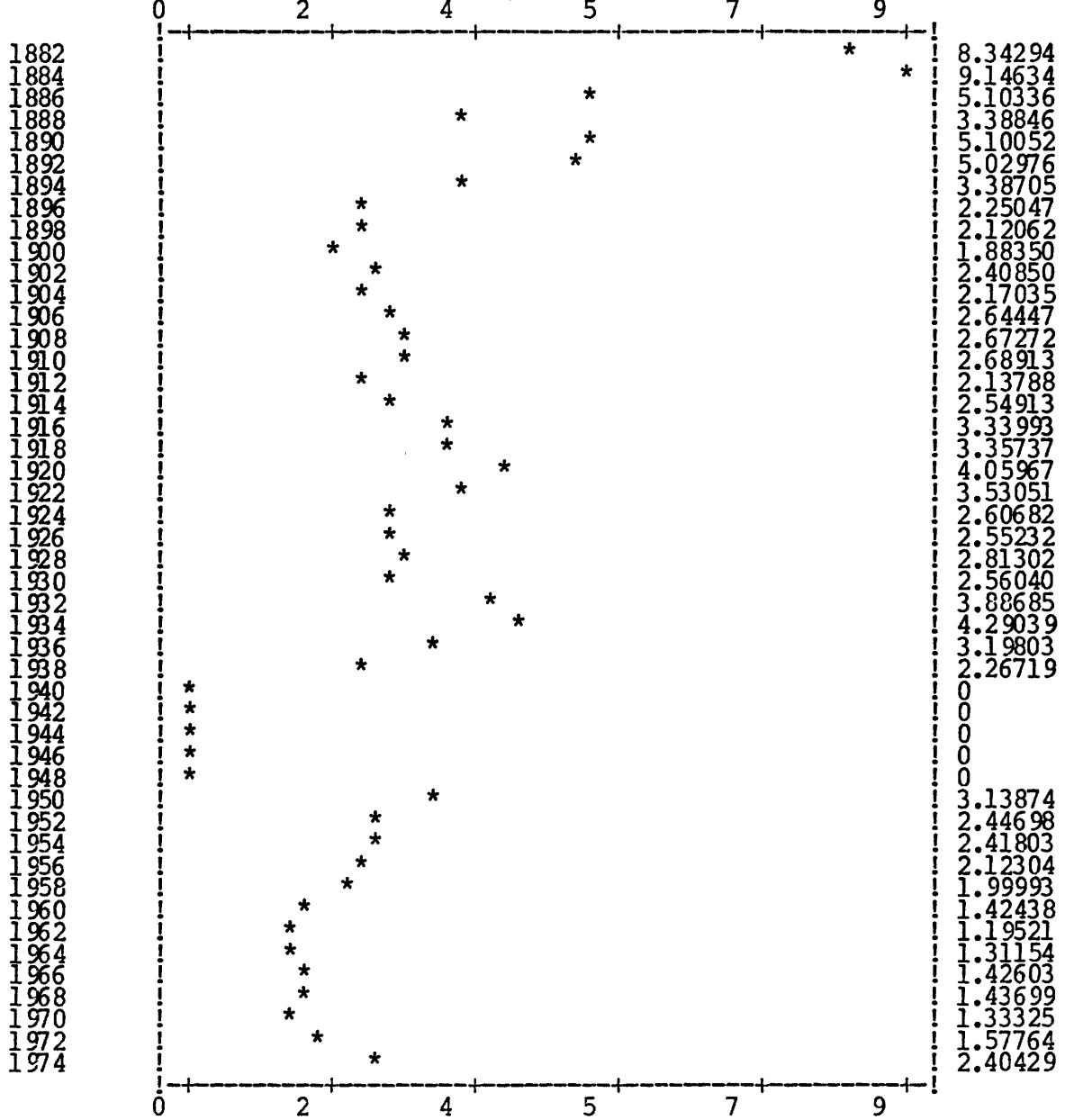



Cl. 70 Writing and drawing appliances

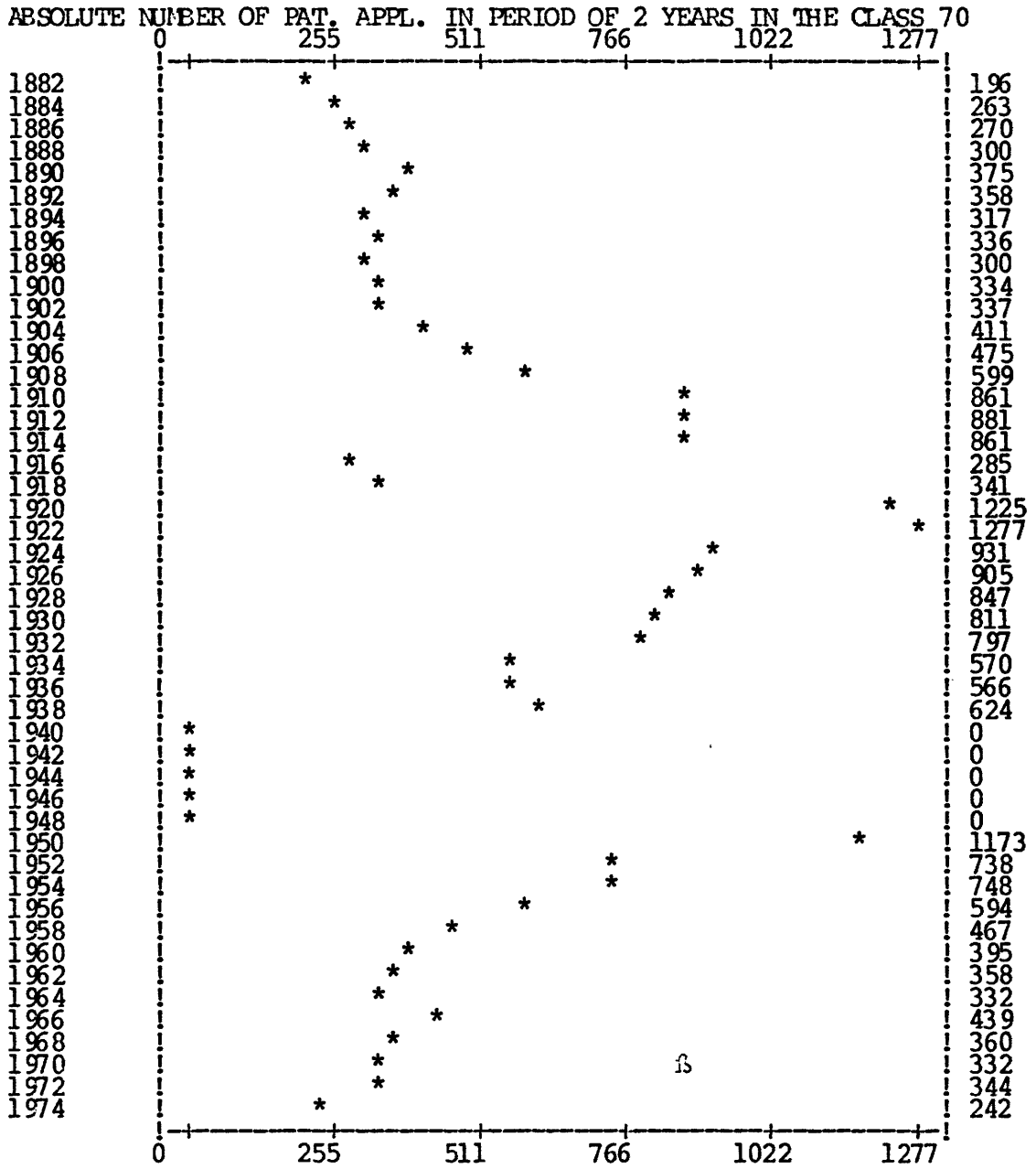

PROPORTION OF TOTAL PAT. APPL. IN 1/1000 IN THE CLASS 70

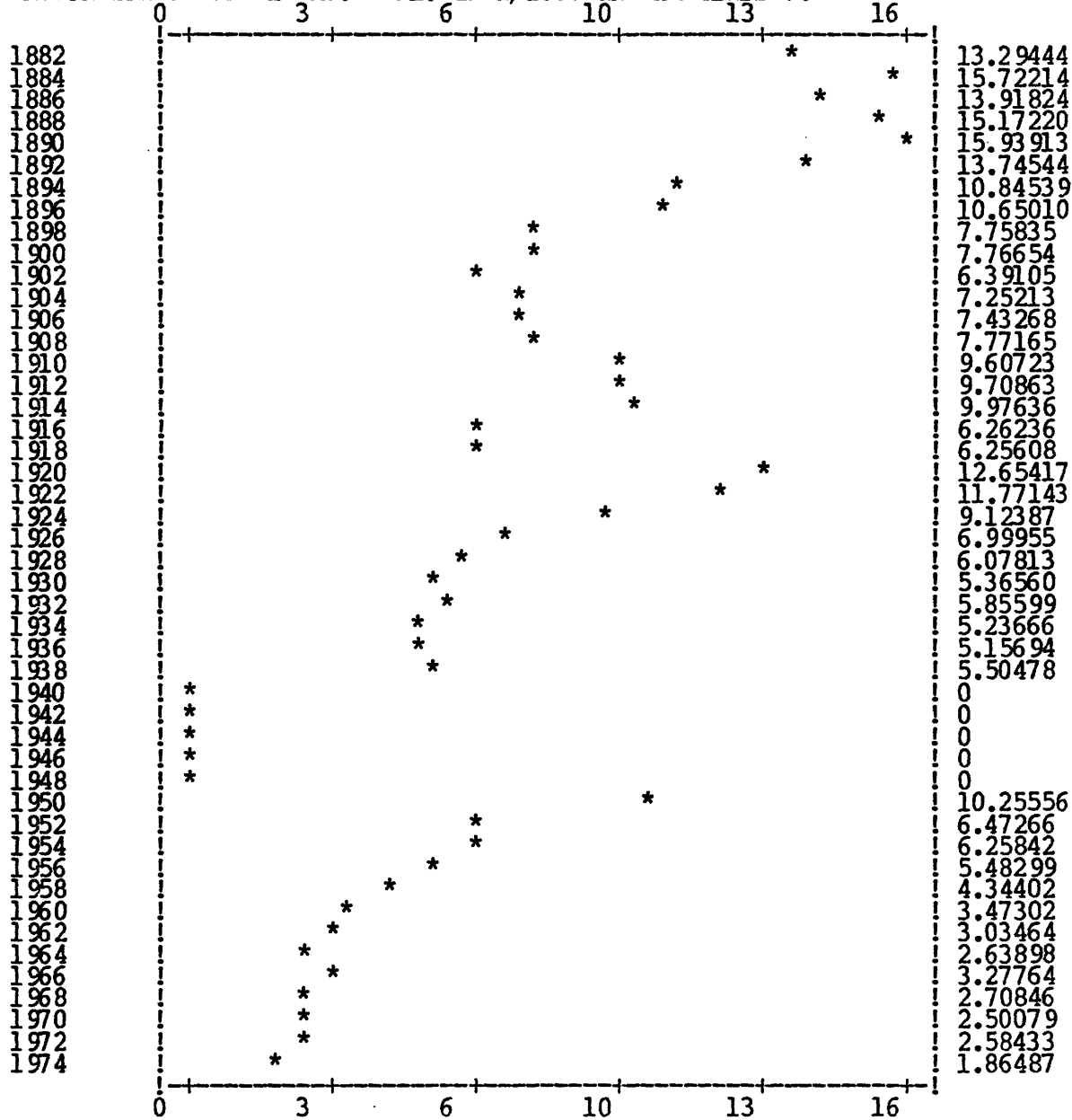

Cl. 71 Footwear

ABSOLUTE NUMBER OF PAT. APPL. IN PERIOD OF 2 YEARS IN THE CLASS 71

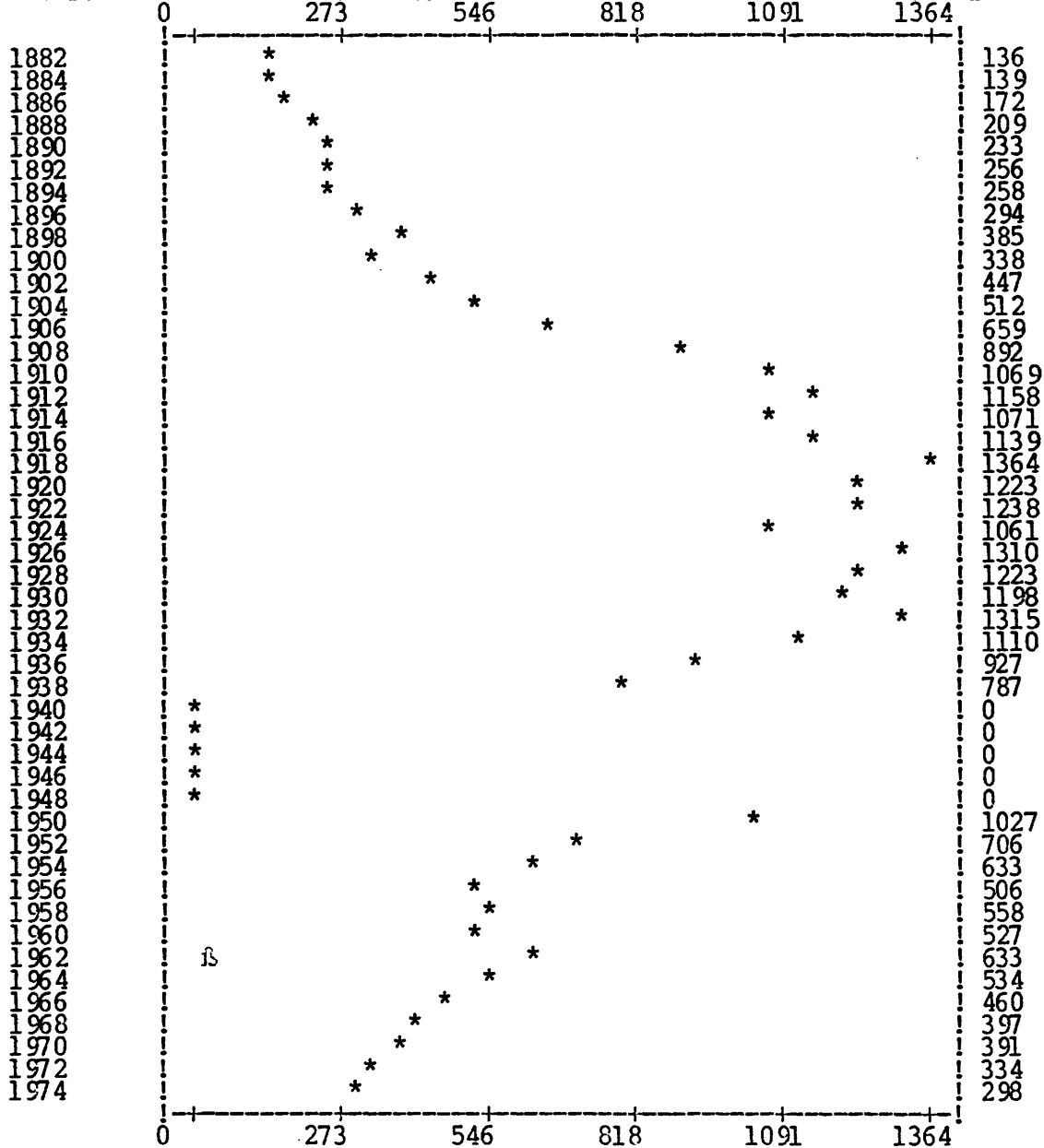

PROPORTION OF TOTAL PAT. APPL. IN 1/1000 IN THE CLASS 71

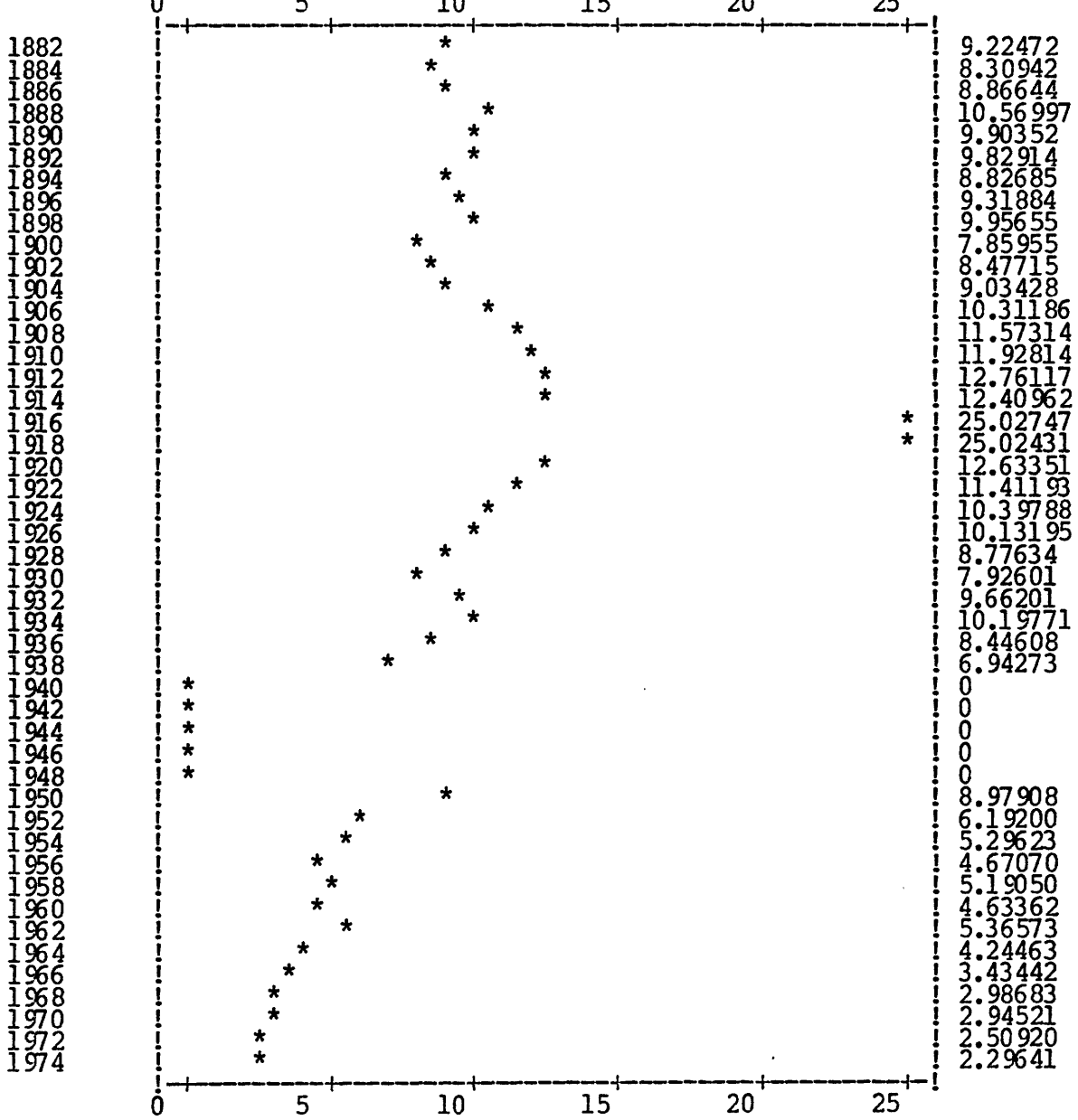

Cl. 72 Fire arms, ammunition, fortifications

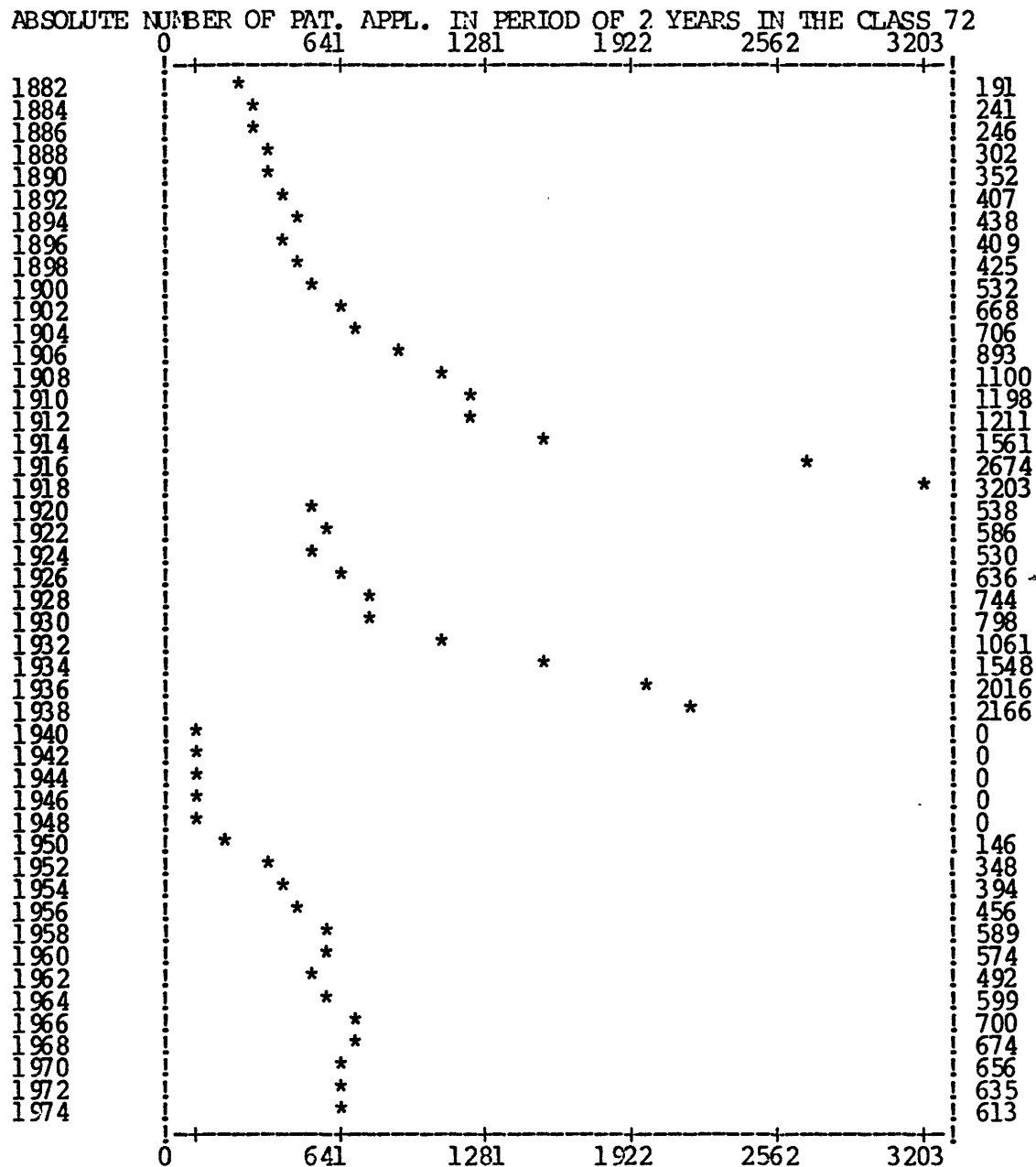

PROPORTION OF TOTAL PAT. APPL. IN 1/1000 IN THE CLASS 72

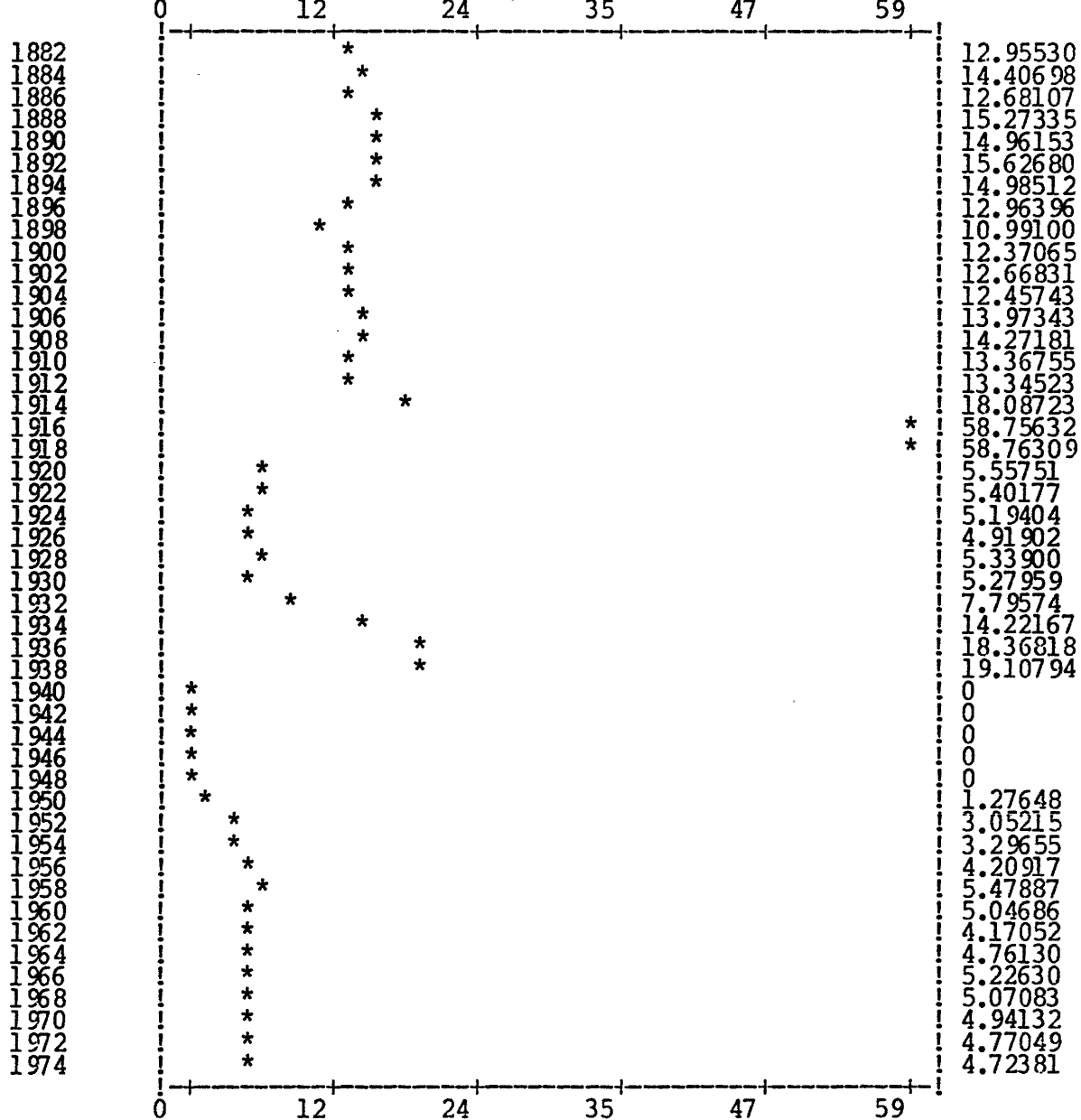

Cl. 73 Ropes

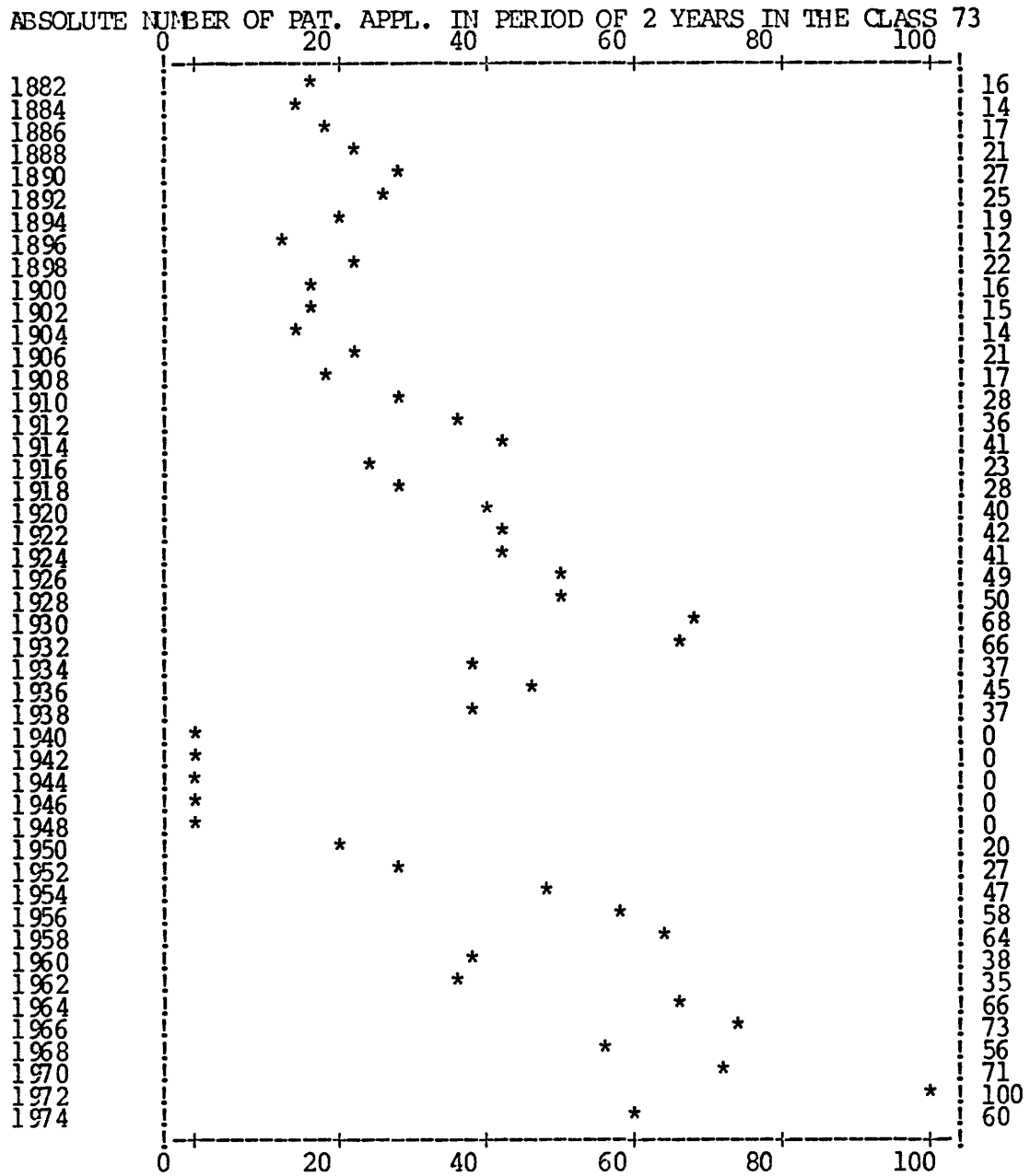

PROPORTION OF TOTAL PAT. APPL. IN 1/1000 IN THE CLASS 73

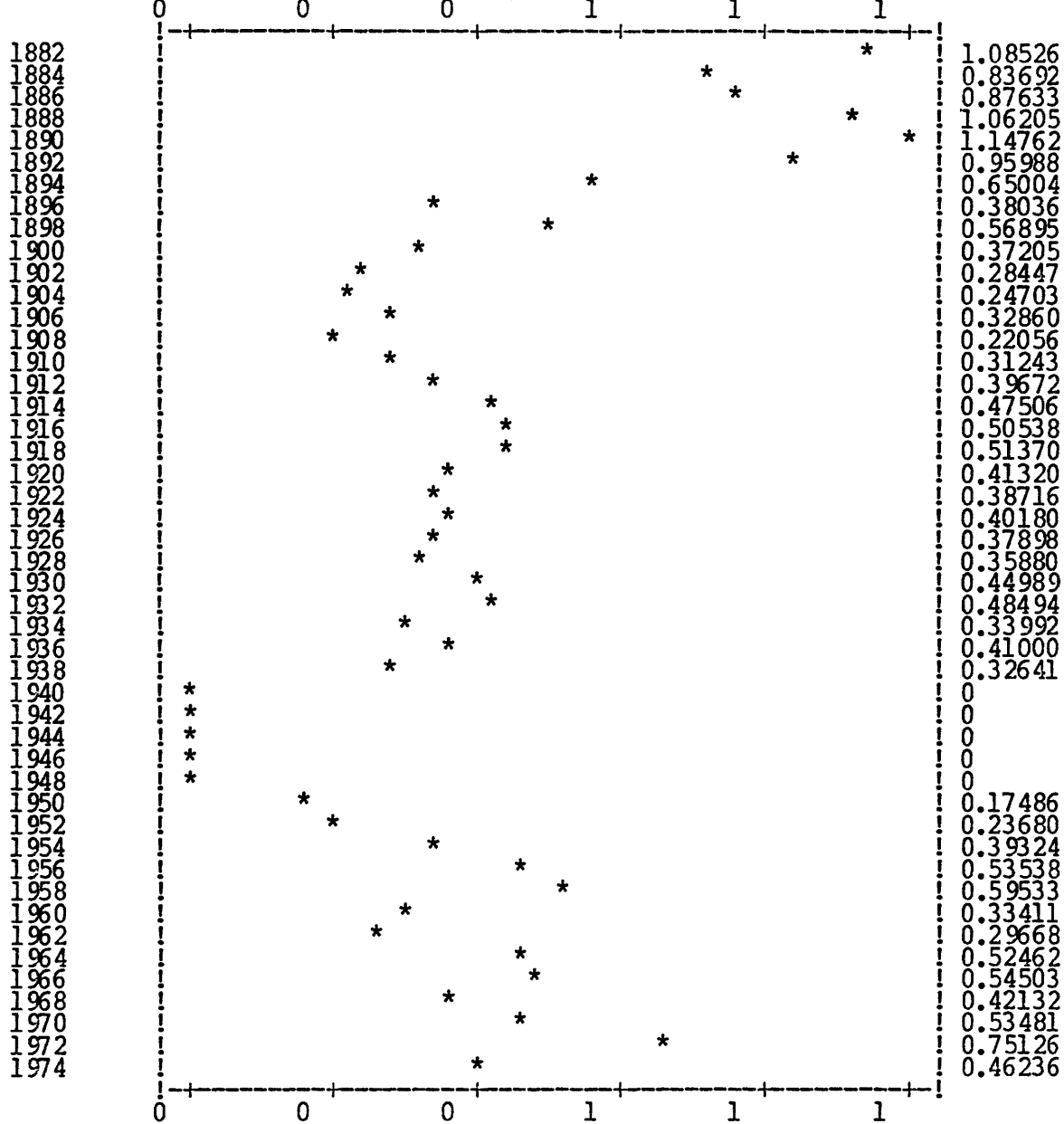



Cl. 74 Signalling

ABSOLUTE NUMBER OF PAT. APPL. IN PERIOD OF 2 YEARS IN THE CLASS 74

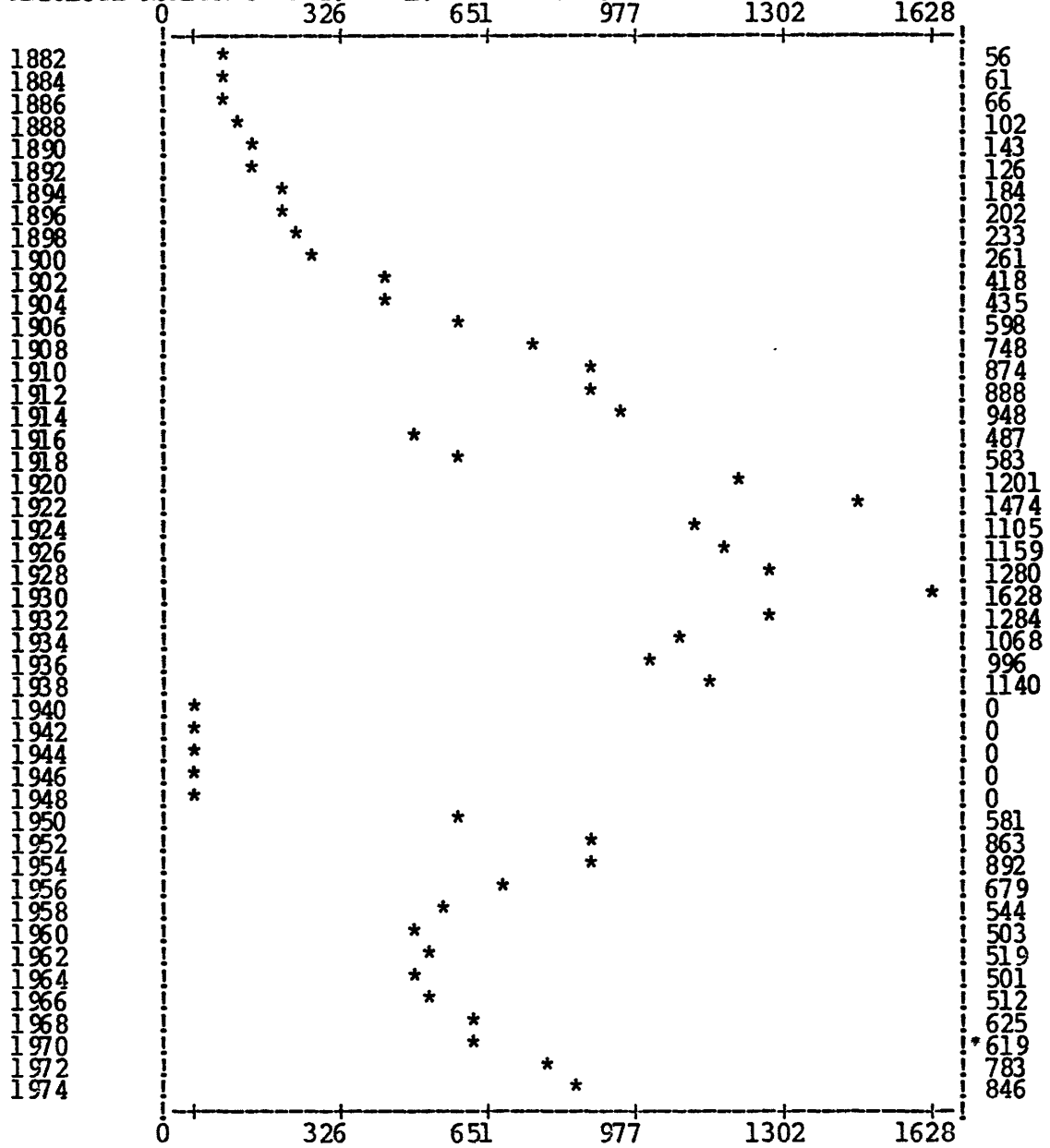

PROPORTION OF TOTAL PAT. APPL. IN 1/1000 IN THE CLASS 74

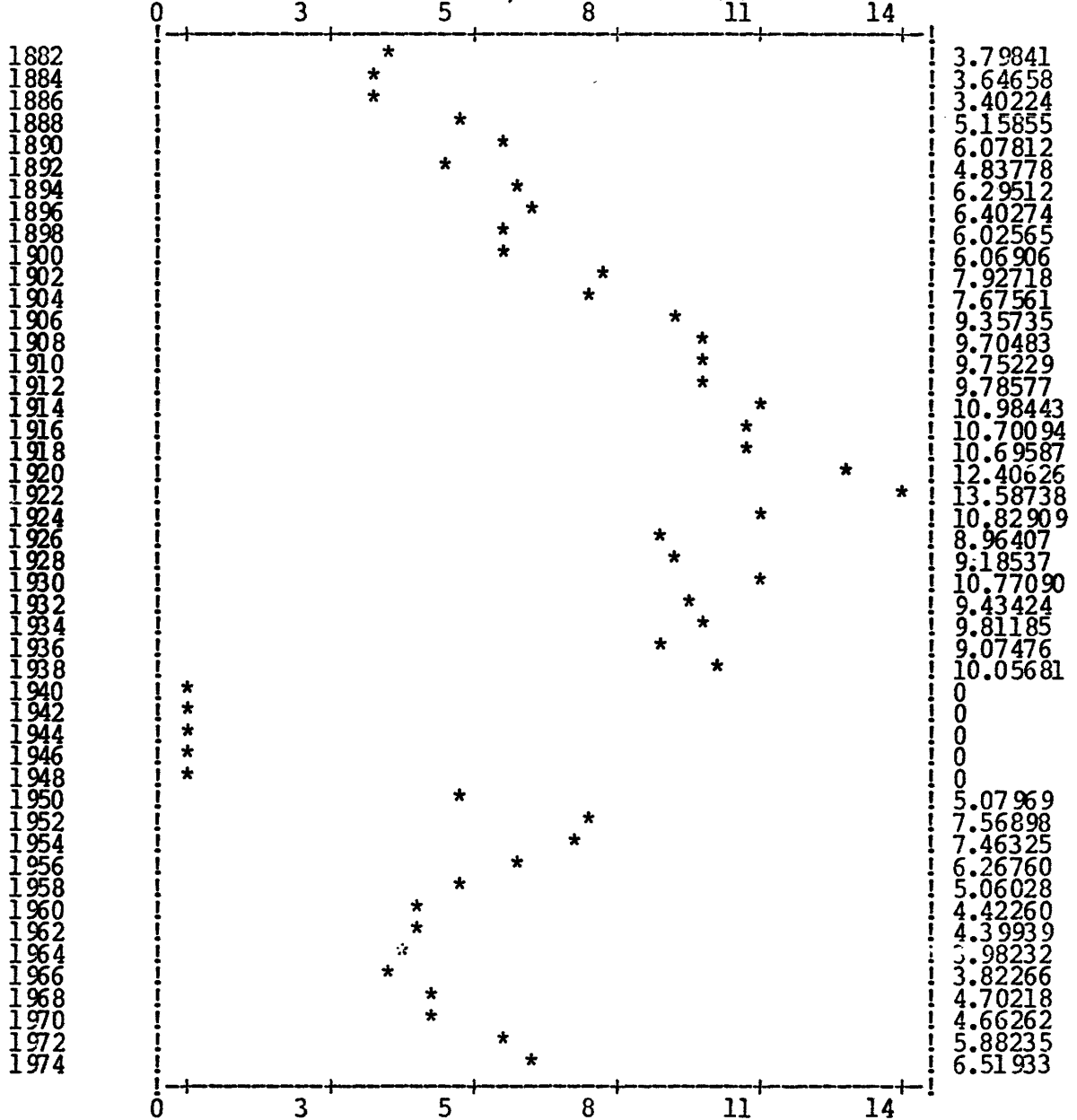

Cl. 75 Sculpture, painting, ornamentation of surfaces

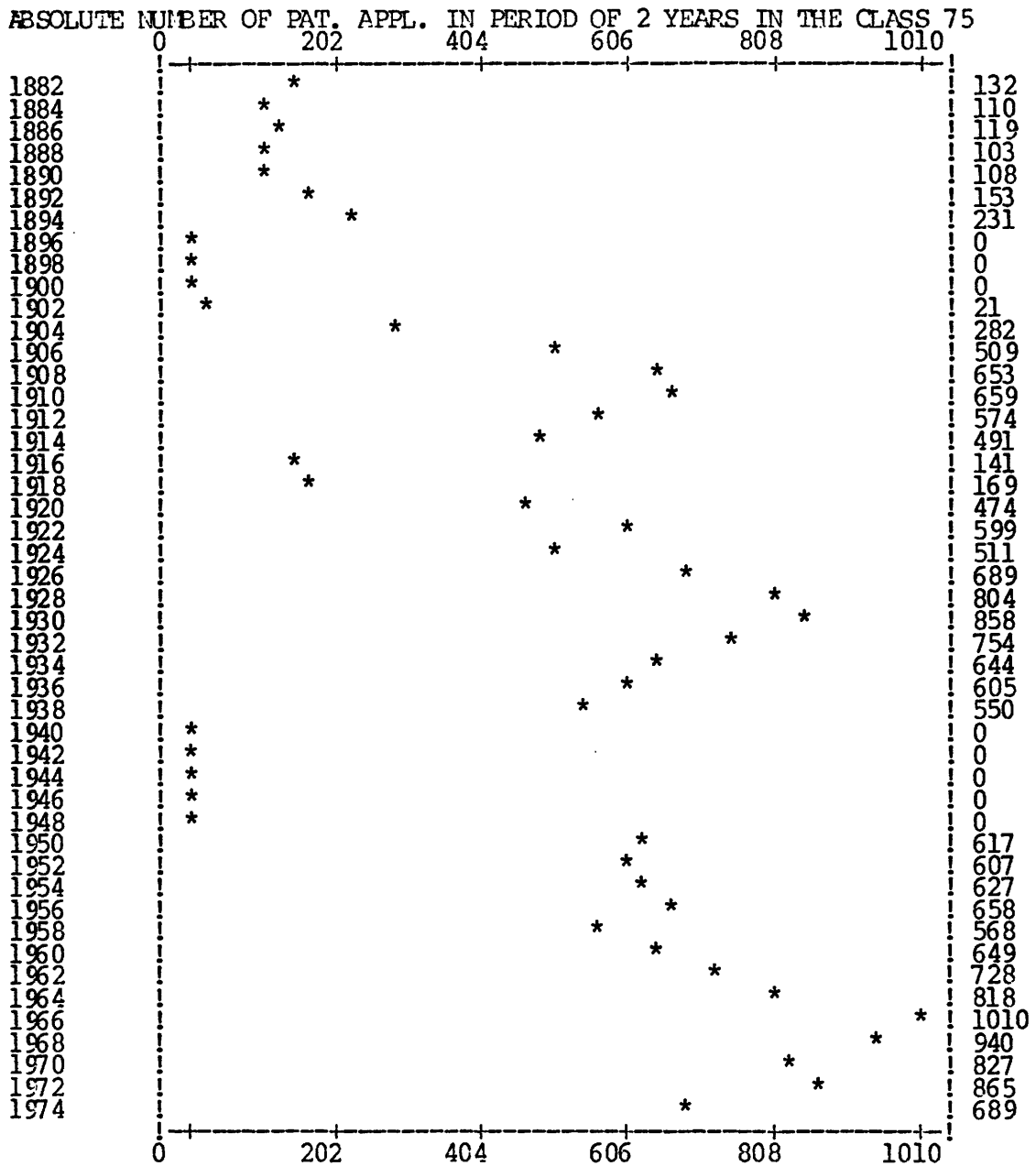

J. VALENTIN IN FRANKFURT A. M.

**Selbstschließendes Auslauf-Ventil.**

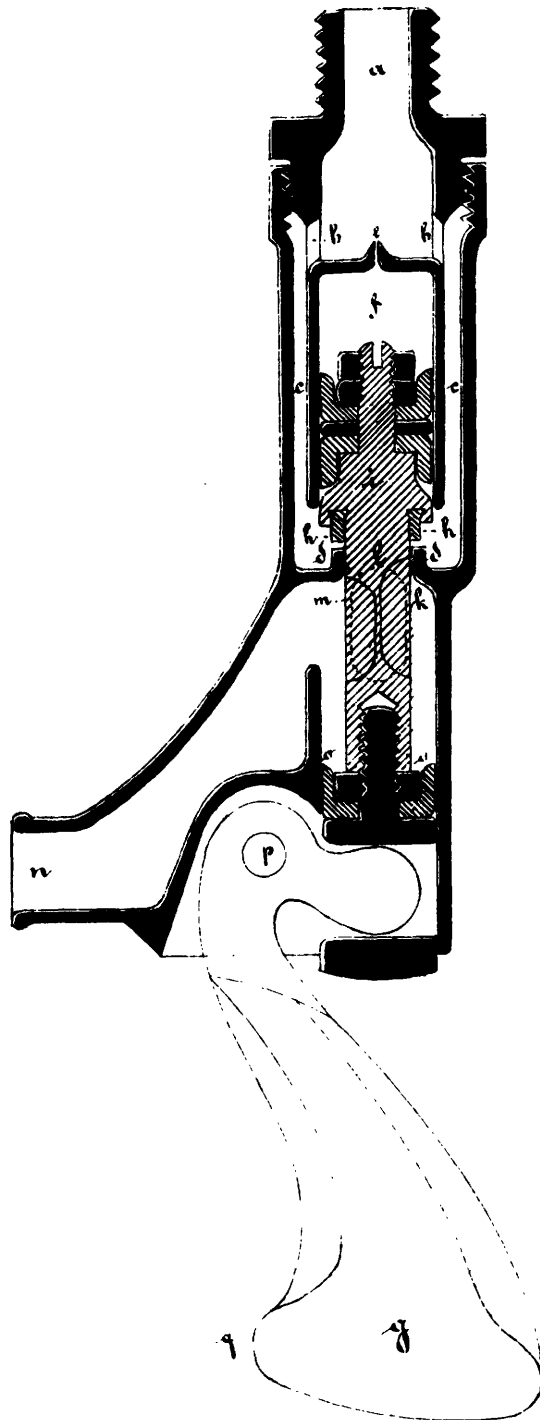

Zu der Patentschrift

**№ 127.**

PHOTOG. DRUCK DER KÖNIGL. PREUSS. STAATSDRUCKEREI.

F. C. GLASER IN BERLIN.  
Ventil-Hahn für Wasserleitungen.

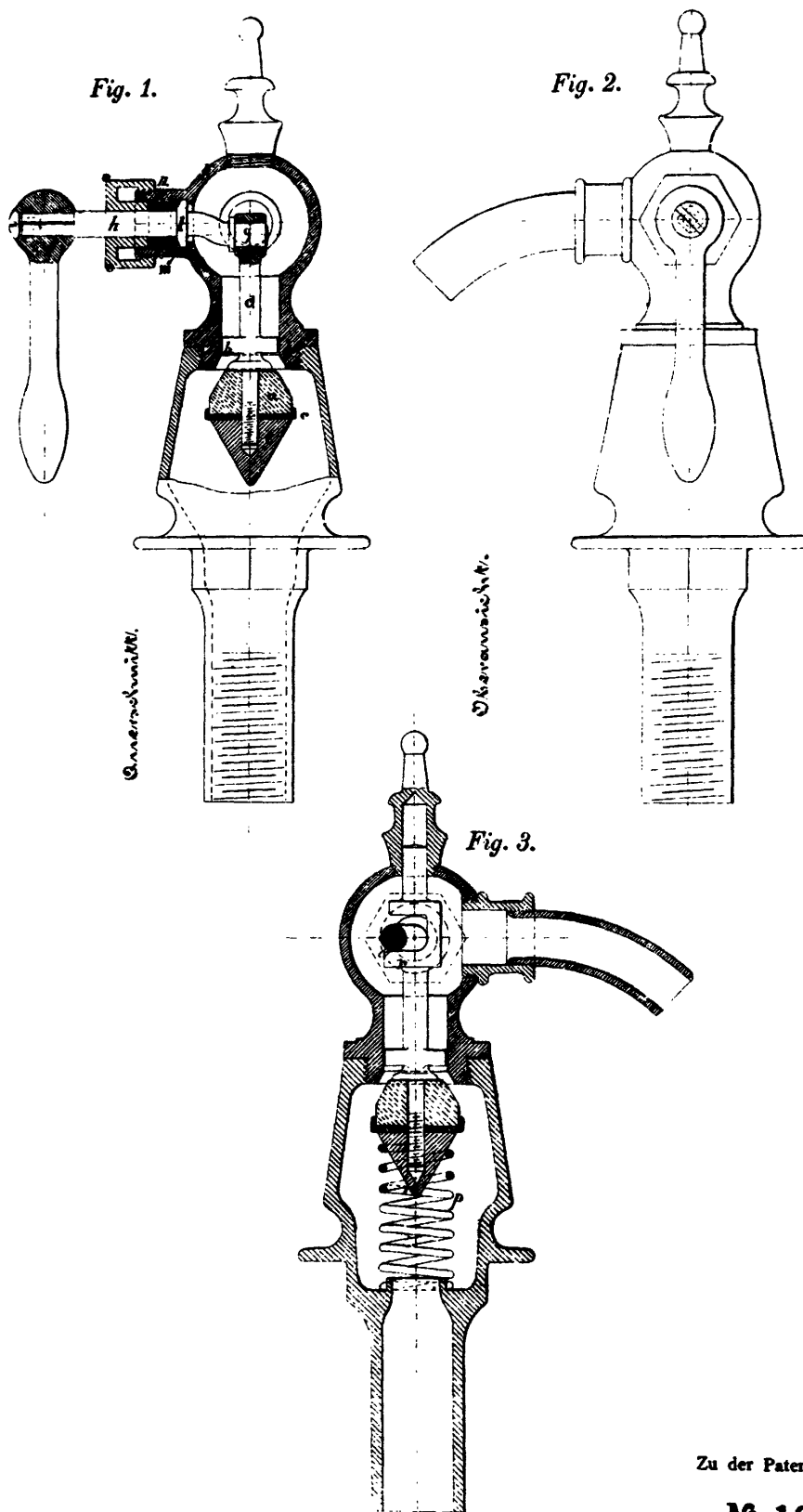

Zu der Patentschrift

№ 126.

PHOTOGR. DRUCK DER KÖNIGL. PREUSS. STAATSDRUCKEREI.

PROPORTION OF TOTAL PAT. APPL. IN 1/1000 IN THE CLASS 75

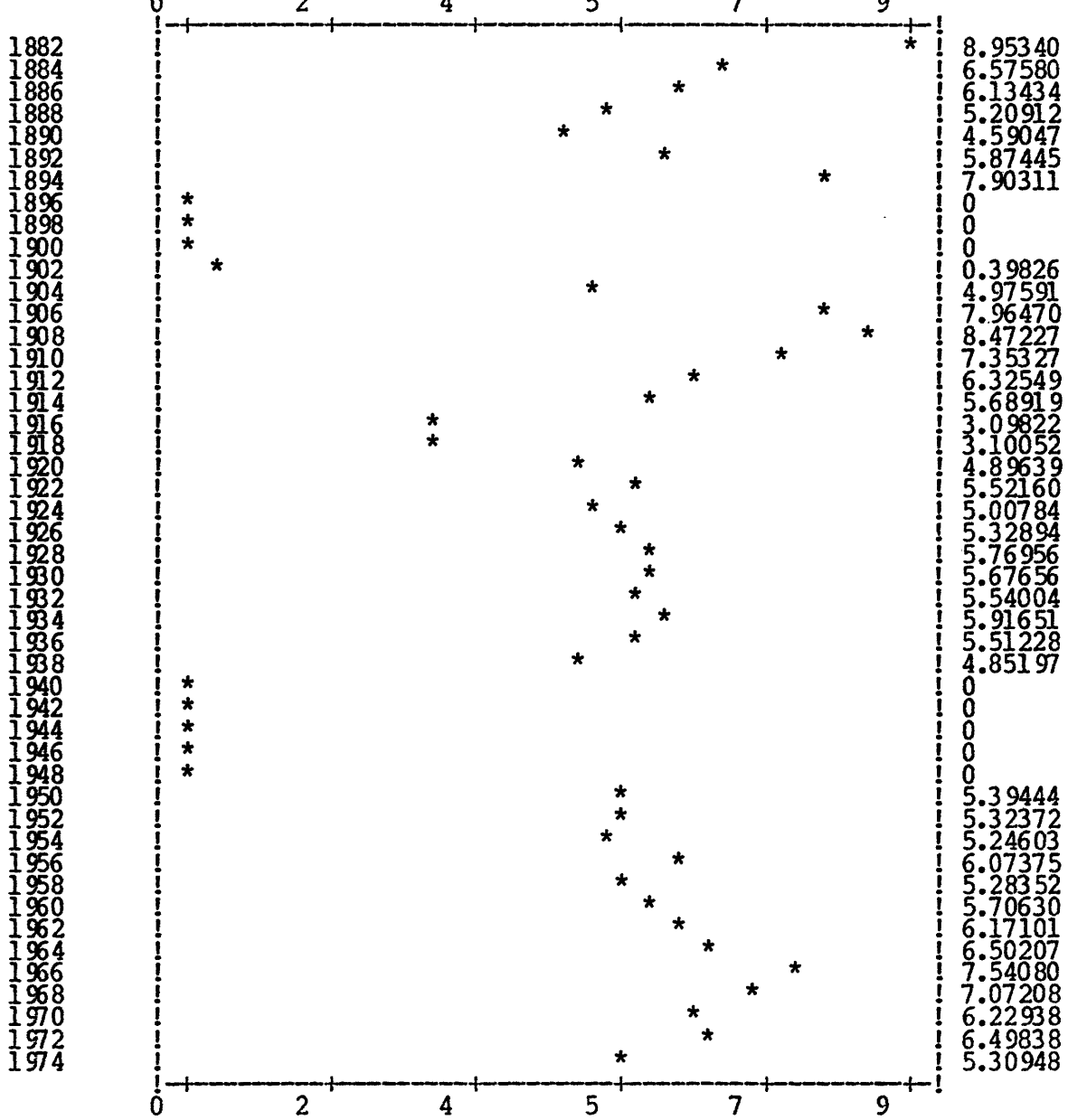

Cl. 76 Spinning

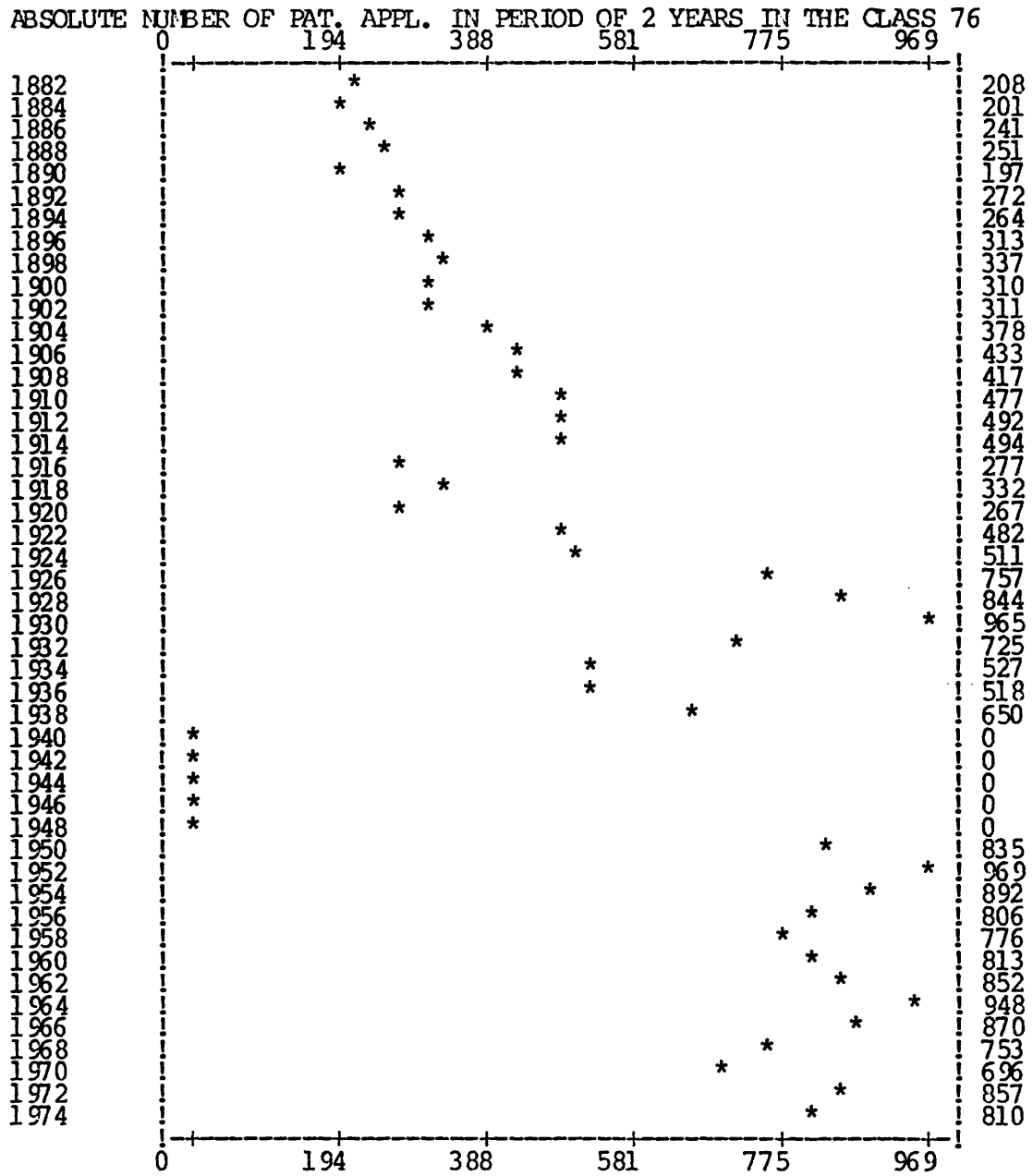

PROPORTION OF TOTAL PAT. APPL. IN 1/1000 IN THE CLASS 76

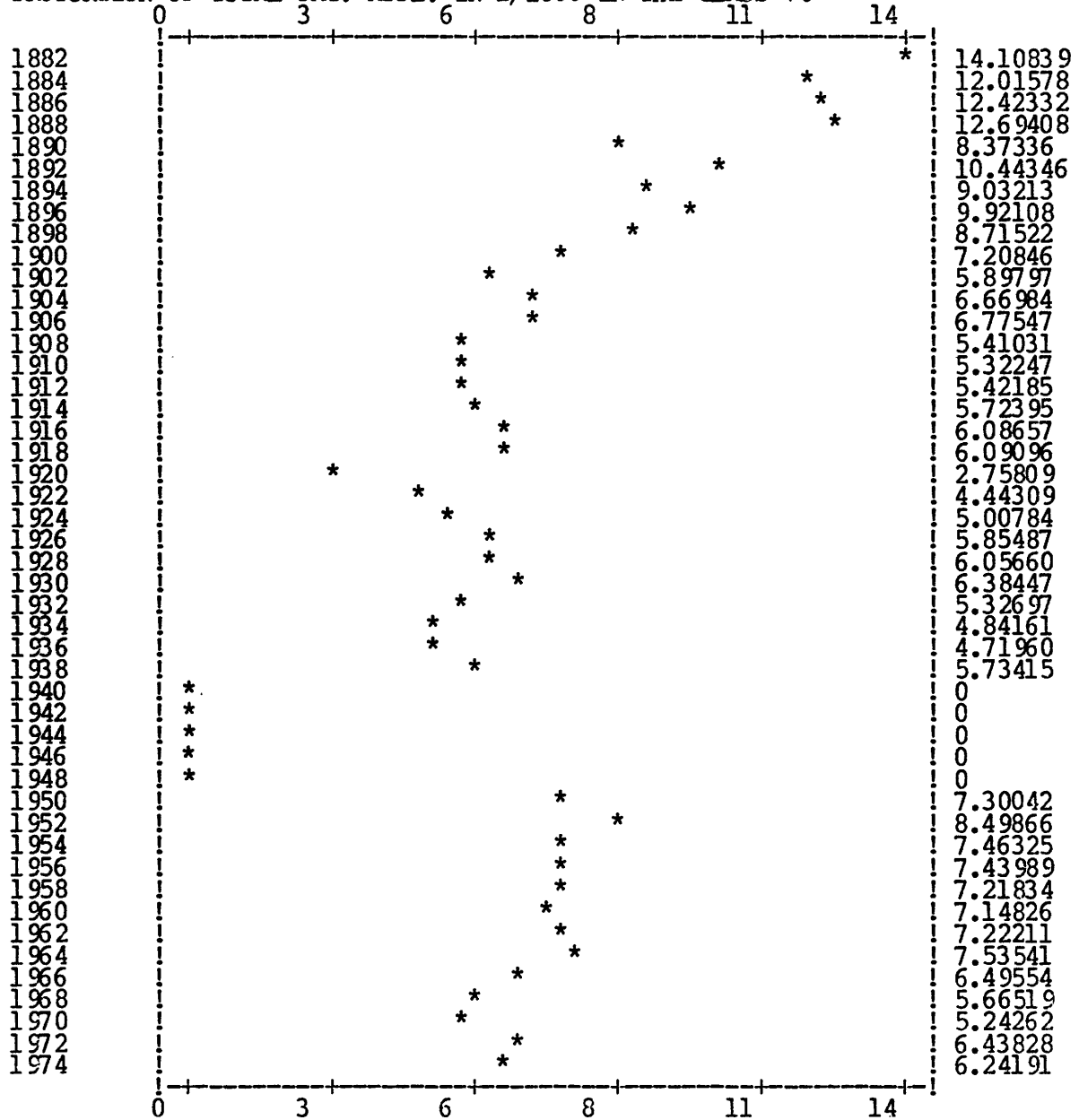



Cl. 77 Sports, games and amusements

ABSOLUTE NUMBER OF PAT. APPL. IN PERIOD OF 2 YEARS IN THE CLASS 77

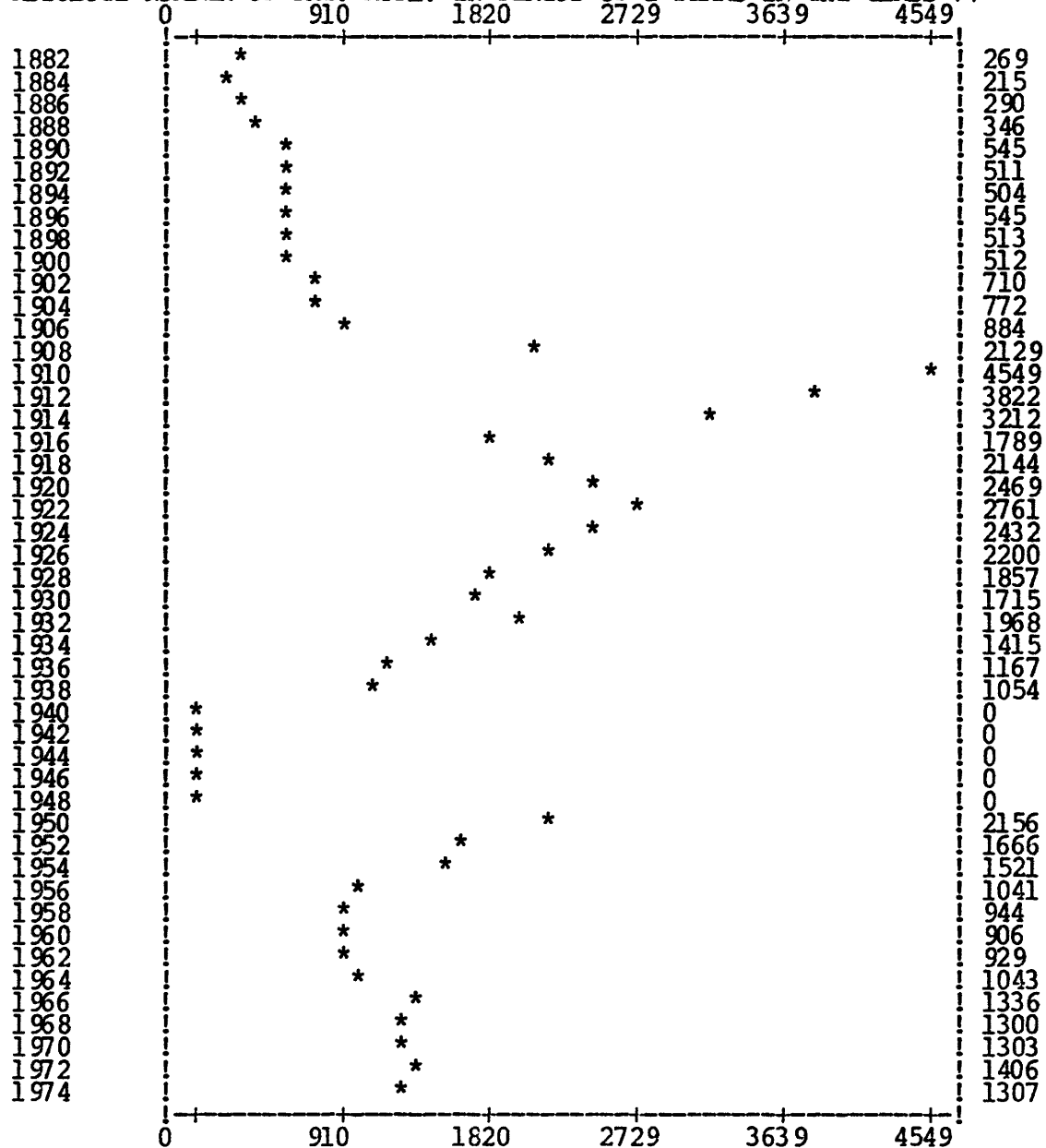

PROPORTION OF TOTAL PAT. APPL. IN 1/1000 IN THE CLASS 77

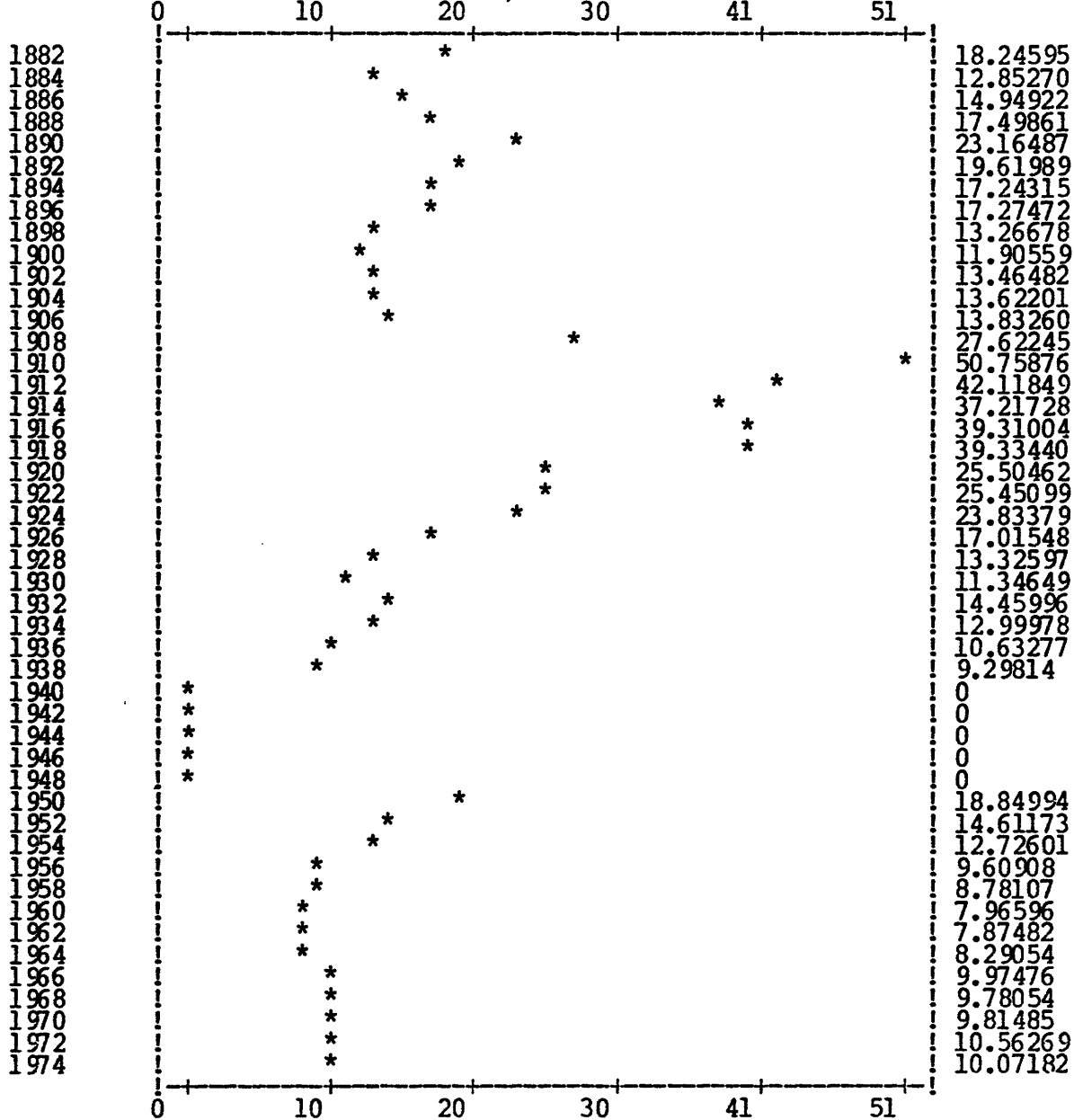

Cl. 78 Explosives, matches, fireworks, flashlights, production of artificial fog

ABSOLUTE NUMBER OF PAT. APPL. IN PERIOD OF 2 YEARS IN THE CLASS 78

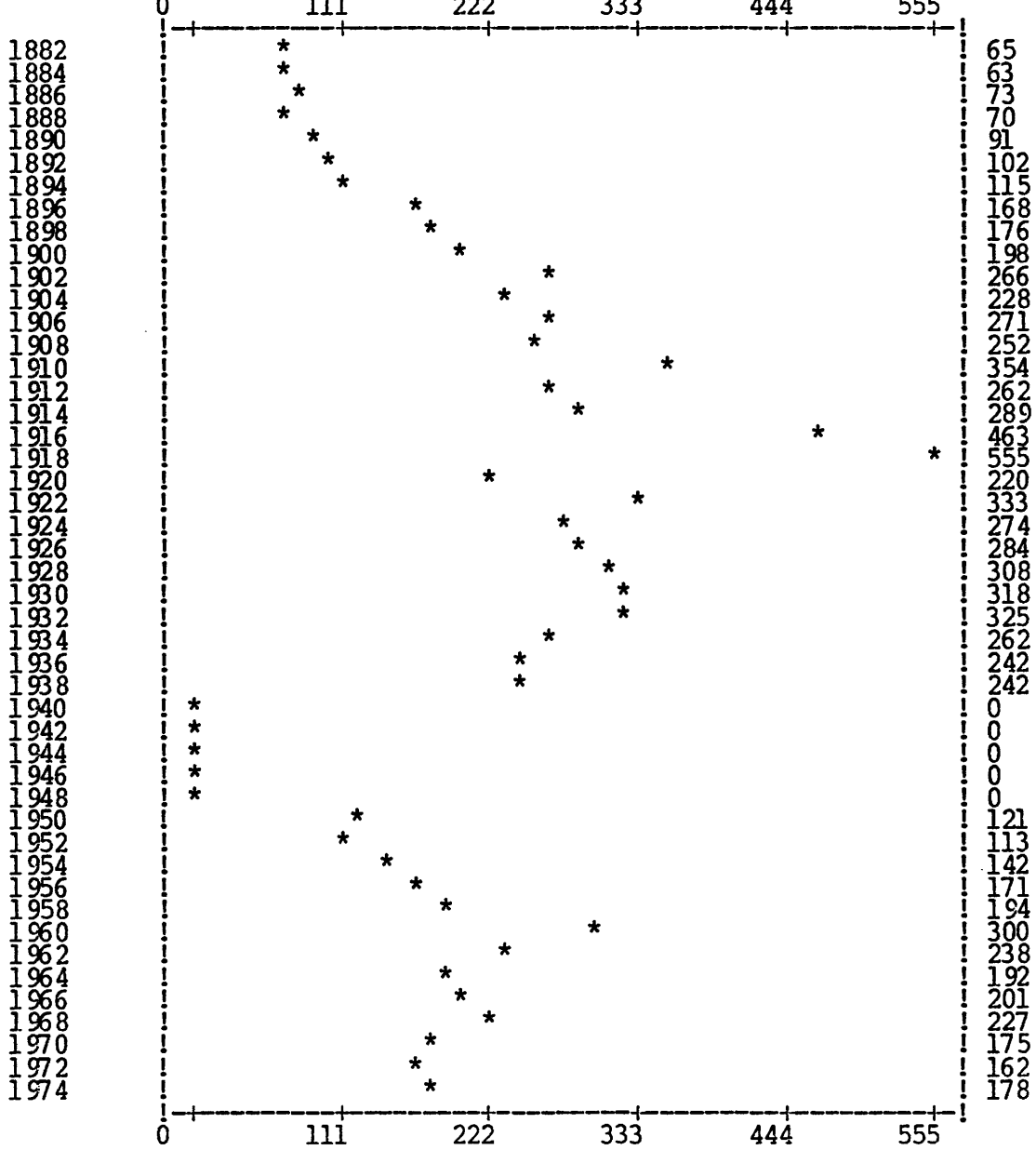

PROPORTION OF TOTAL PAT. APPL. IN 1/1000 IN THE CLASS 78

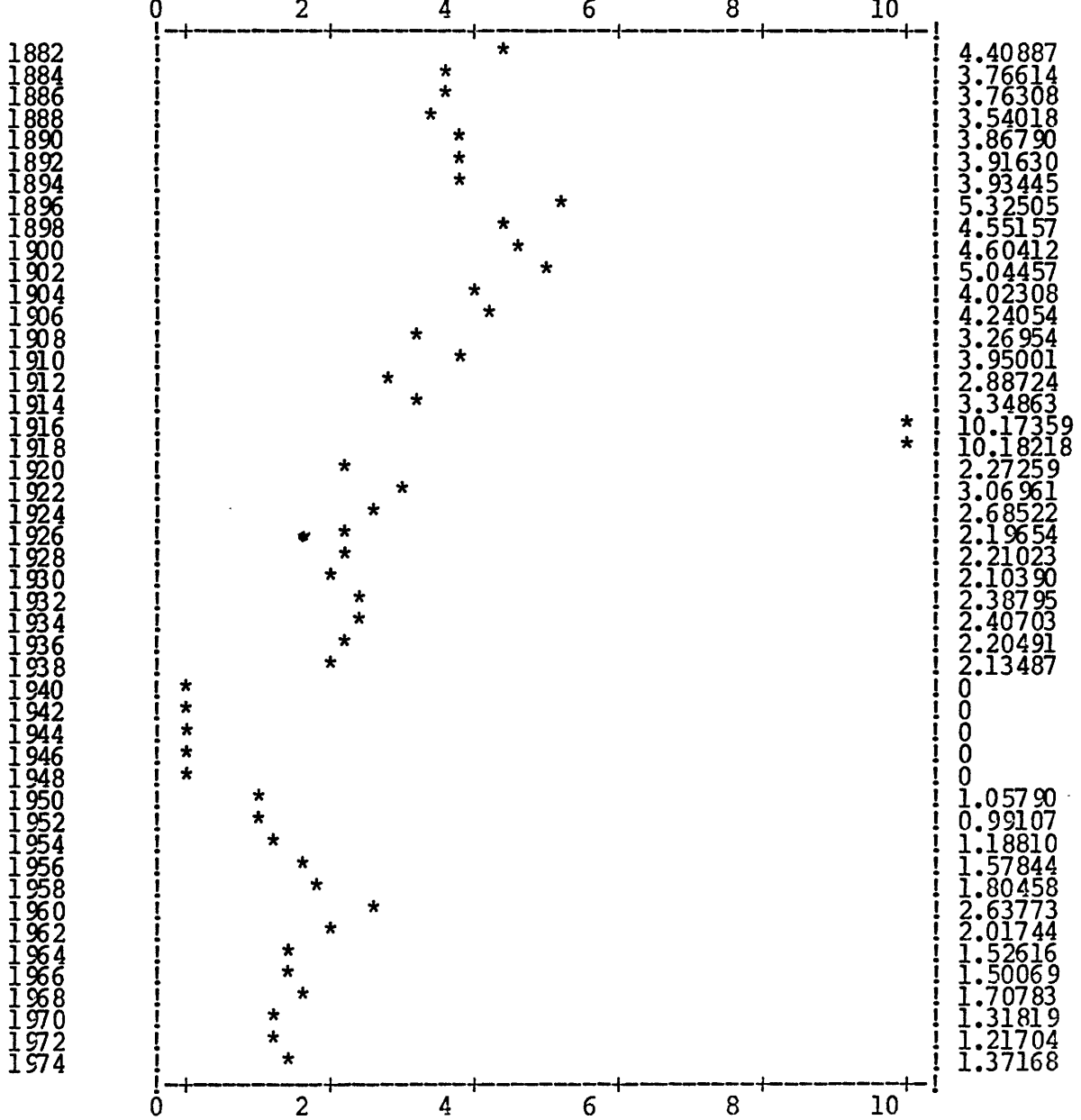

Cl. 79 Tobacco, cigars, cigarettes.

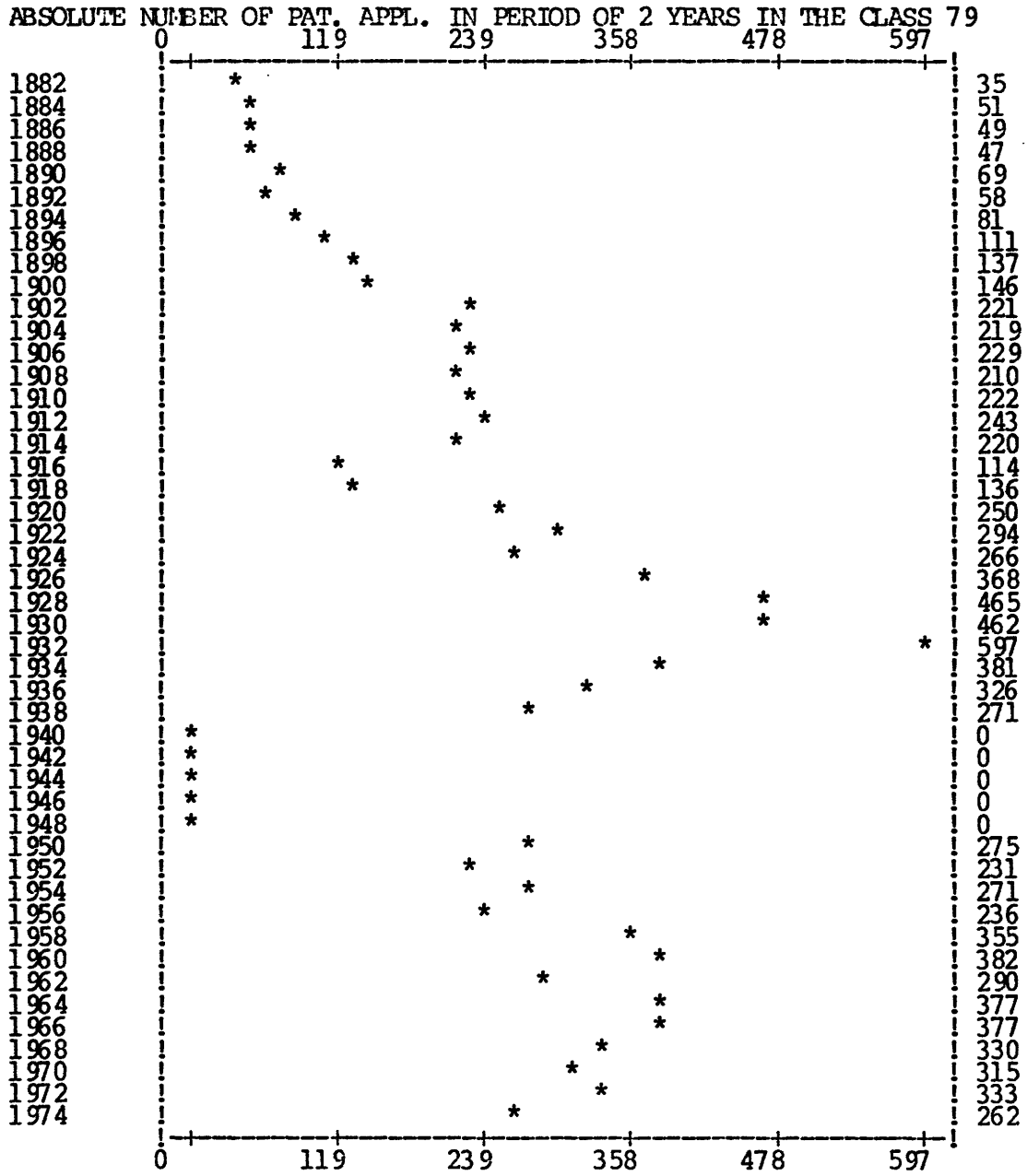

PROPORTION OF TOTAL PAT. APPL. IN 1/1000 IN THE CLASS 79

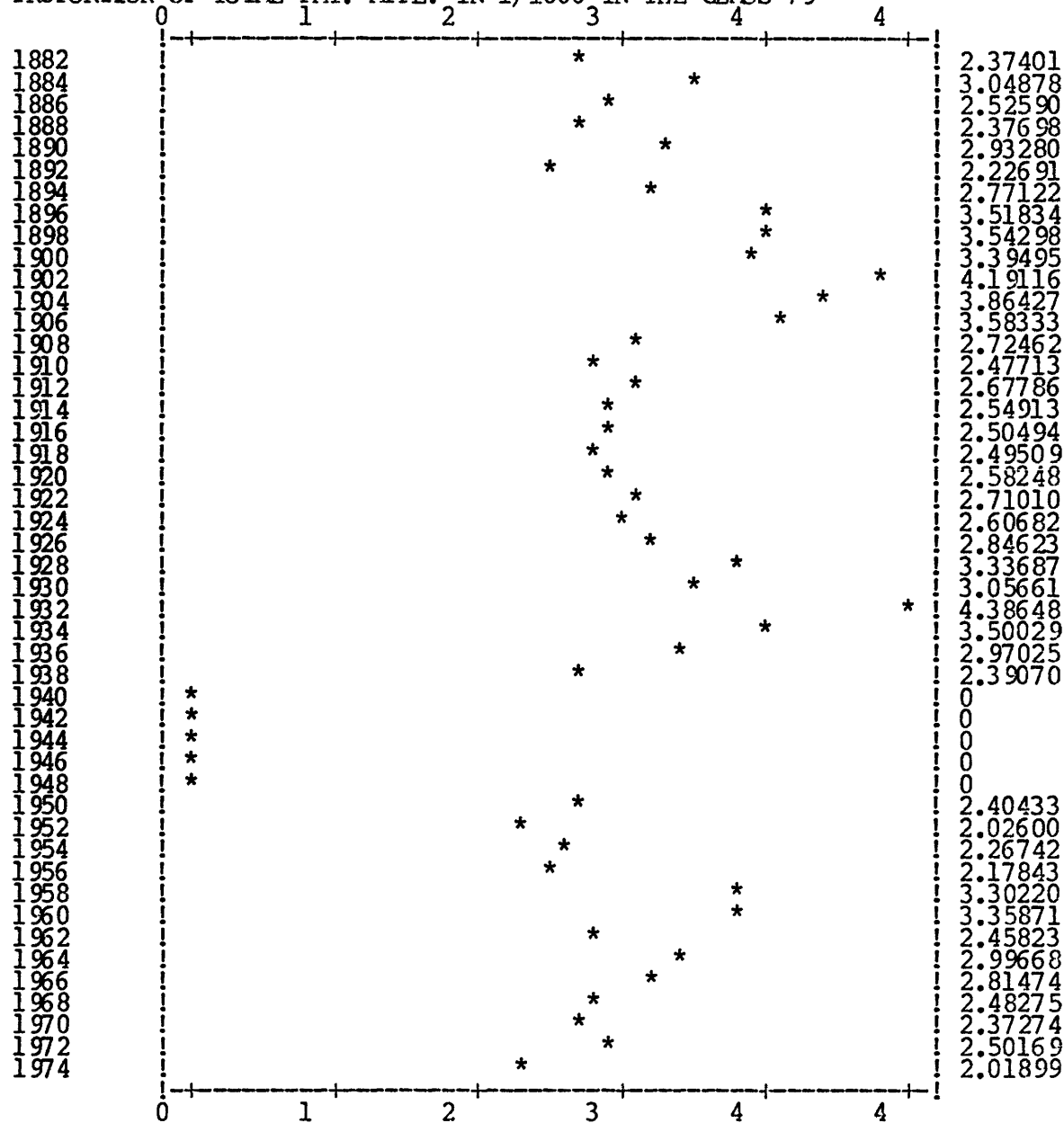

Cl. 80 Clay articles, stones, chalk, cement, plaster, asphalt, briquette presses

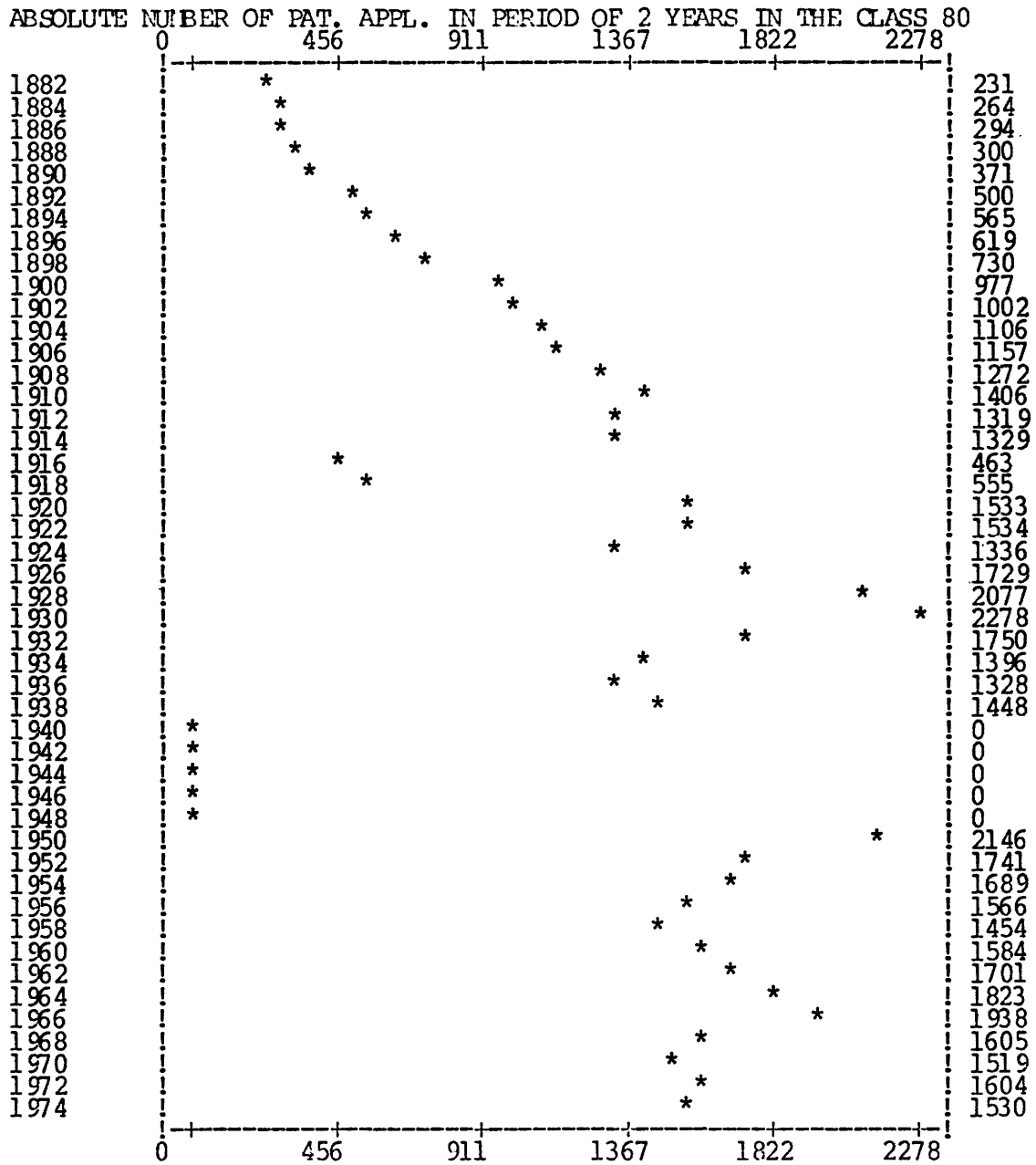

PROPORTION OF TOTAL PAT. APPL. IN 1/1000 IN THE CLASS 80

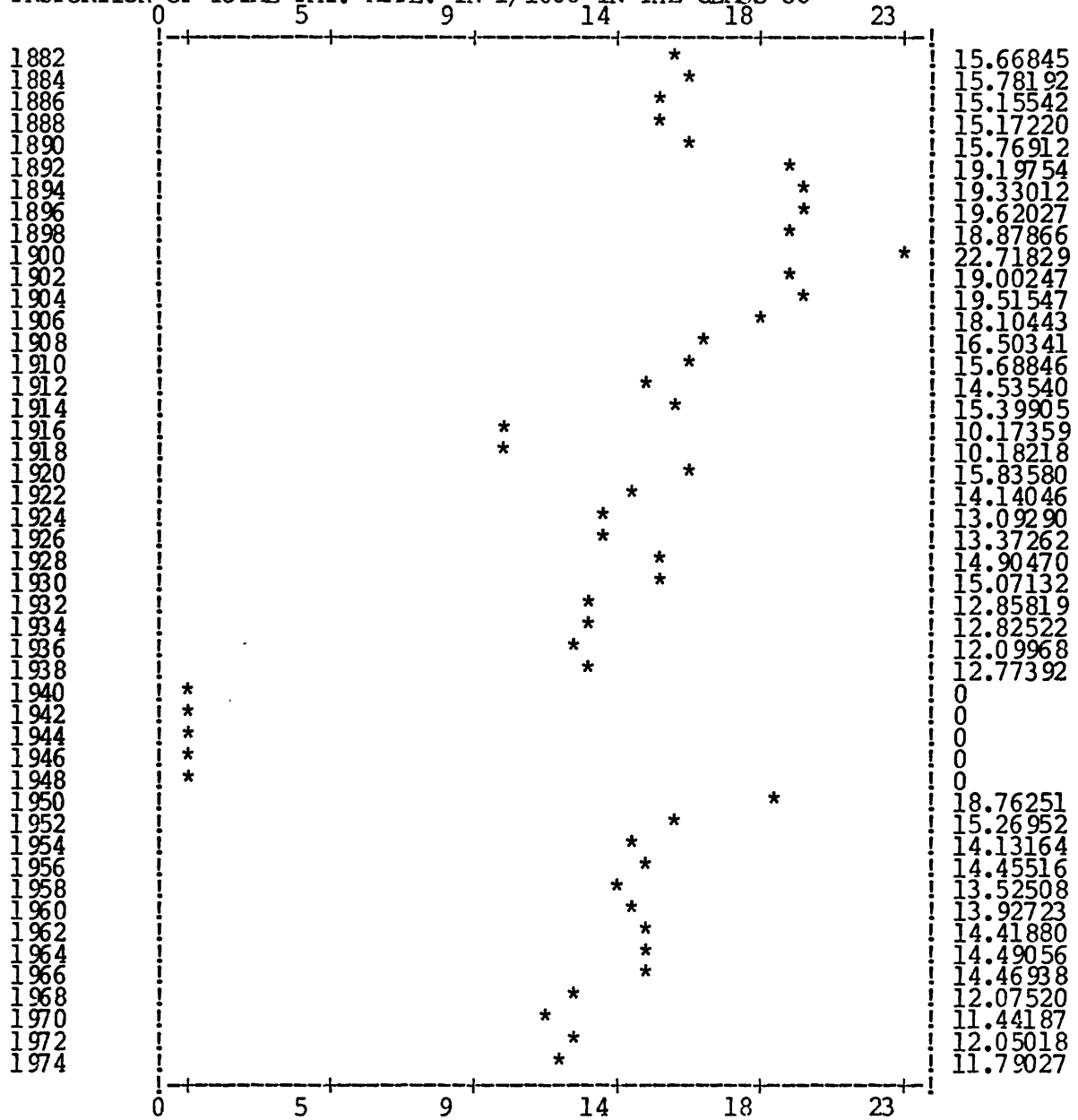



Cl. 81 Transport and packing

ABSOLUTE NUMBER OF PAT. APPL. IN PERIOD OF 2 YEARS IN THE CLASS 81

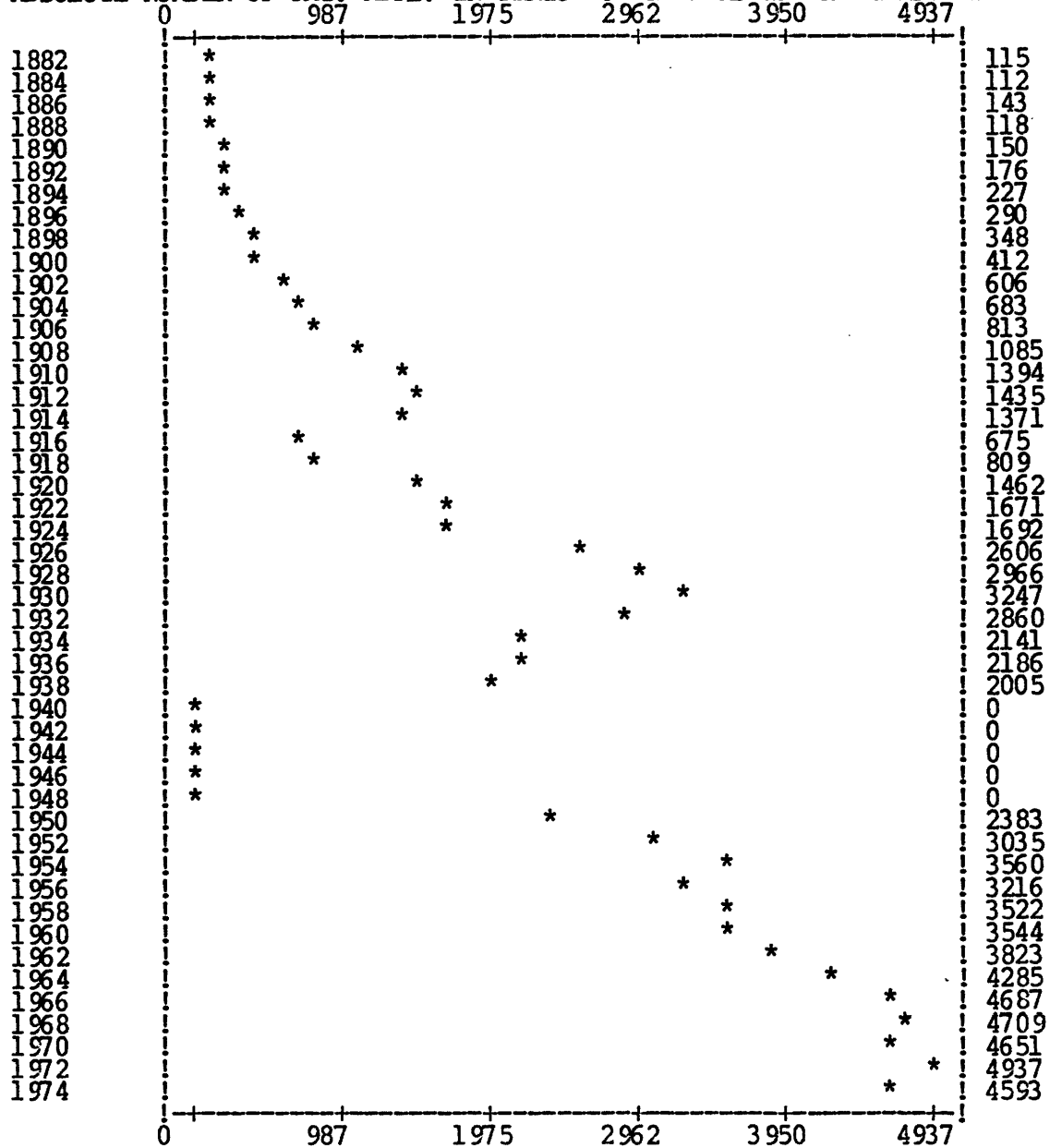

BENJAMIN LOEW IN TILSIT

**Pfropfenzieher.**

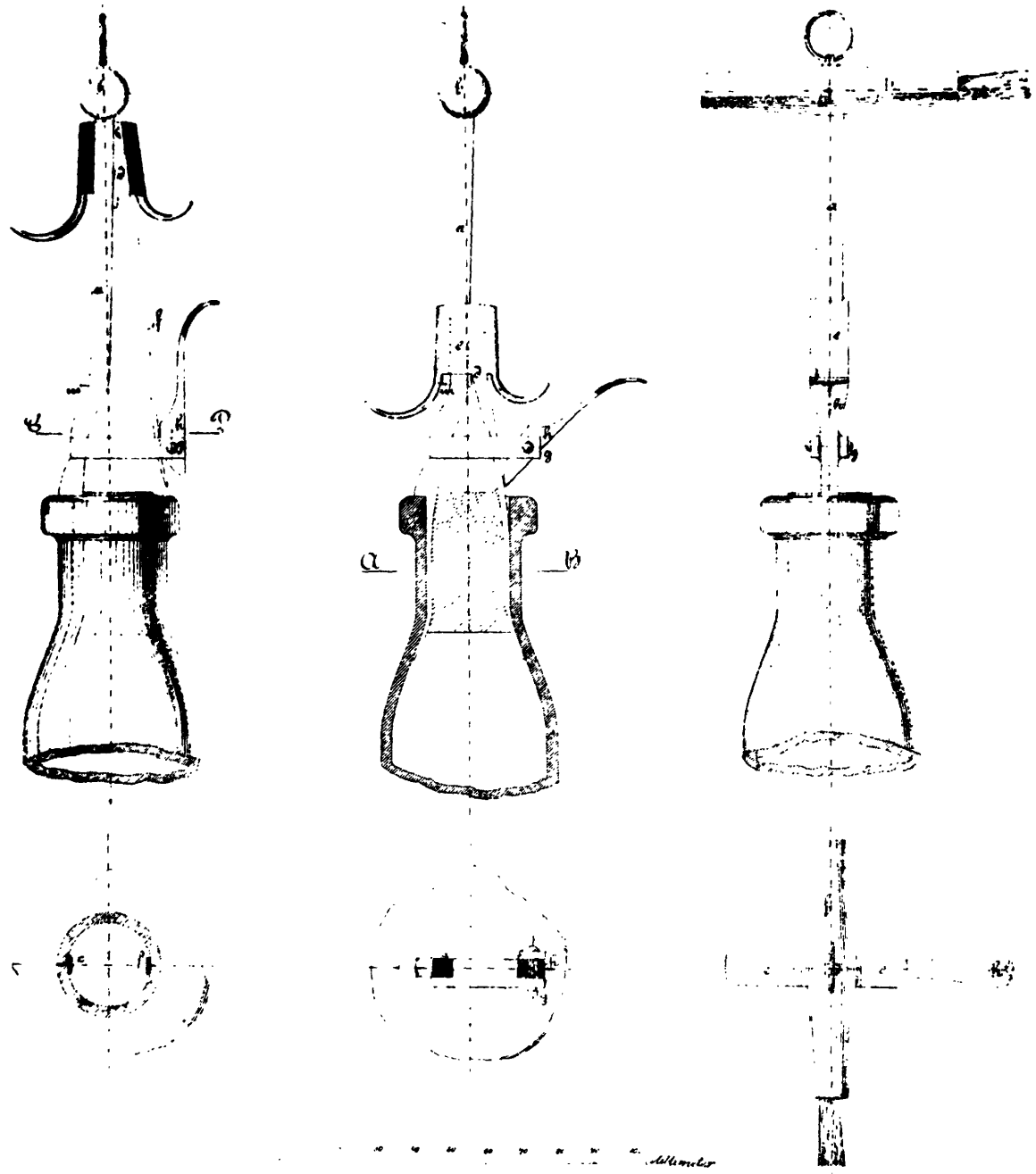

Zu der Patentsch.

**№ 16.**

PHOTOGR. DRUCK DER KÖNIGL. PREUSS. STAATSDRUCKEREI.

FRIEDRICH SCHELLING IN HAMBURG.

Oel-Spritz-Kanne.

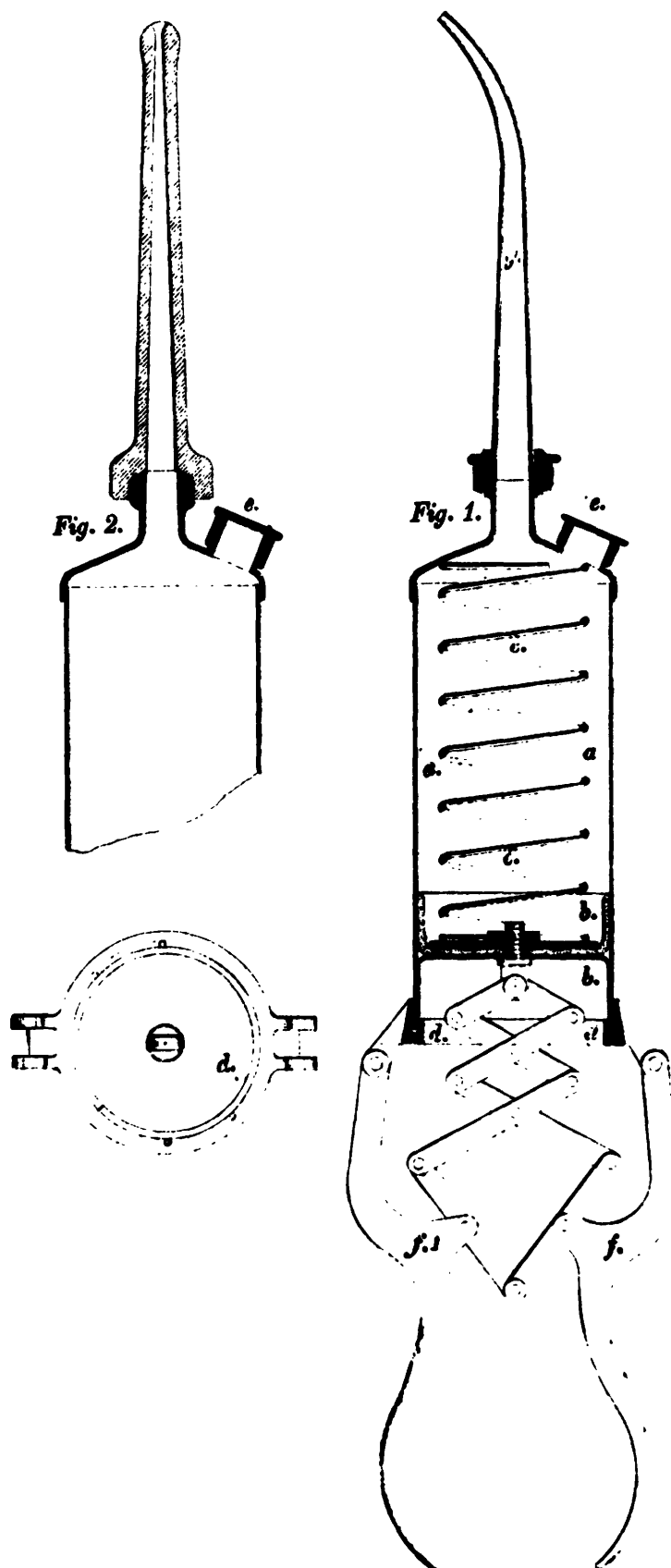

Zu der Patentschrift

№ 56.

PROPORTION OF TOTAL PAT. APPL. IN 1/1000 IN THE CLASS 81

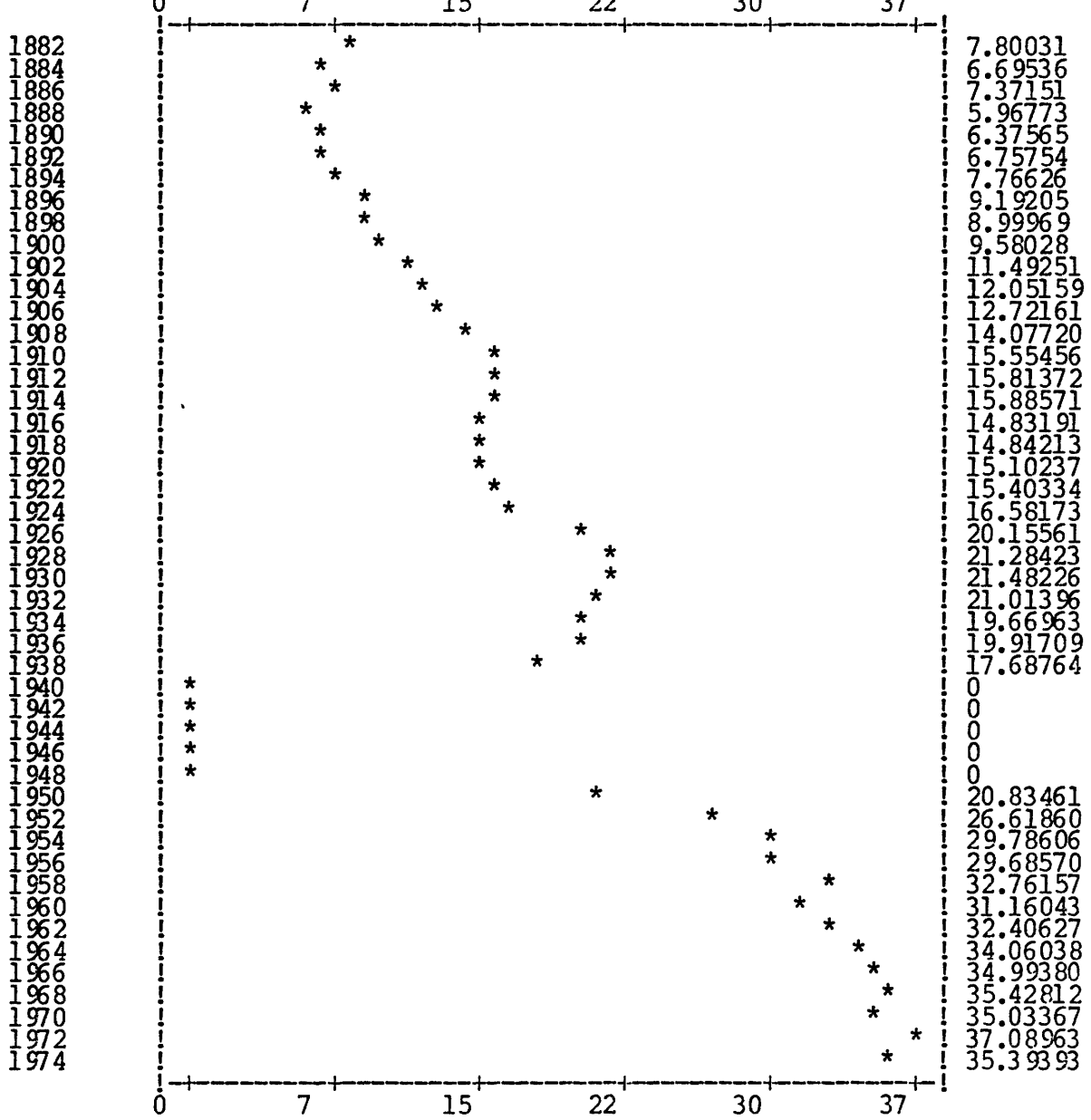

Cl. 82 Drying including drying kilns, coffee roasters, centrifugal apparatus for general purpose

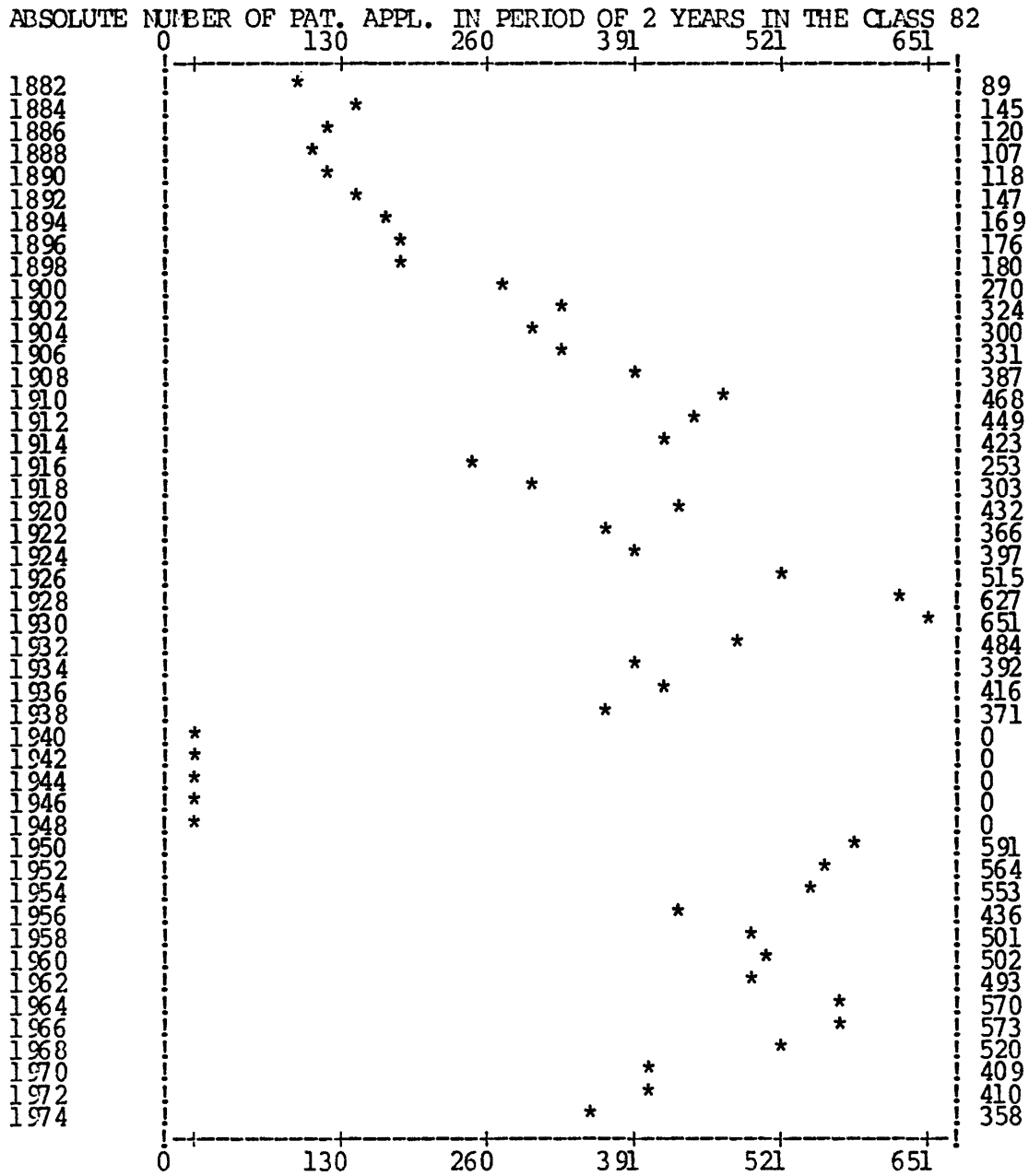

PROPORTION OF TOTAL PAT. APPL. IN 1/1000 IN THE CLASS 82

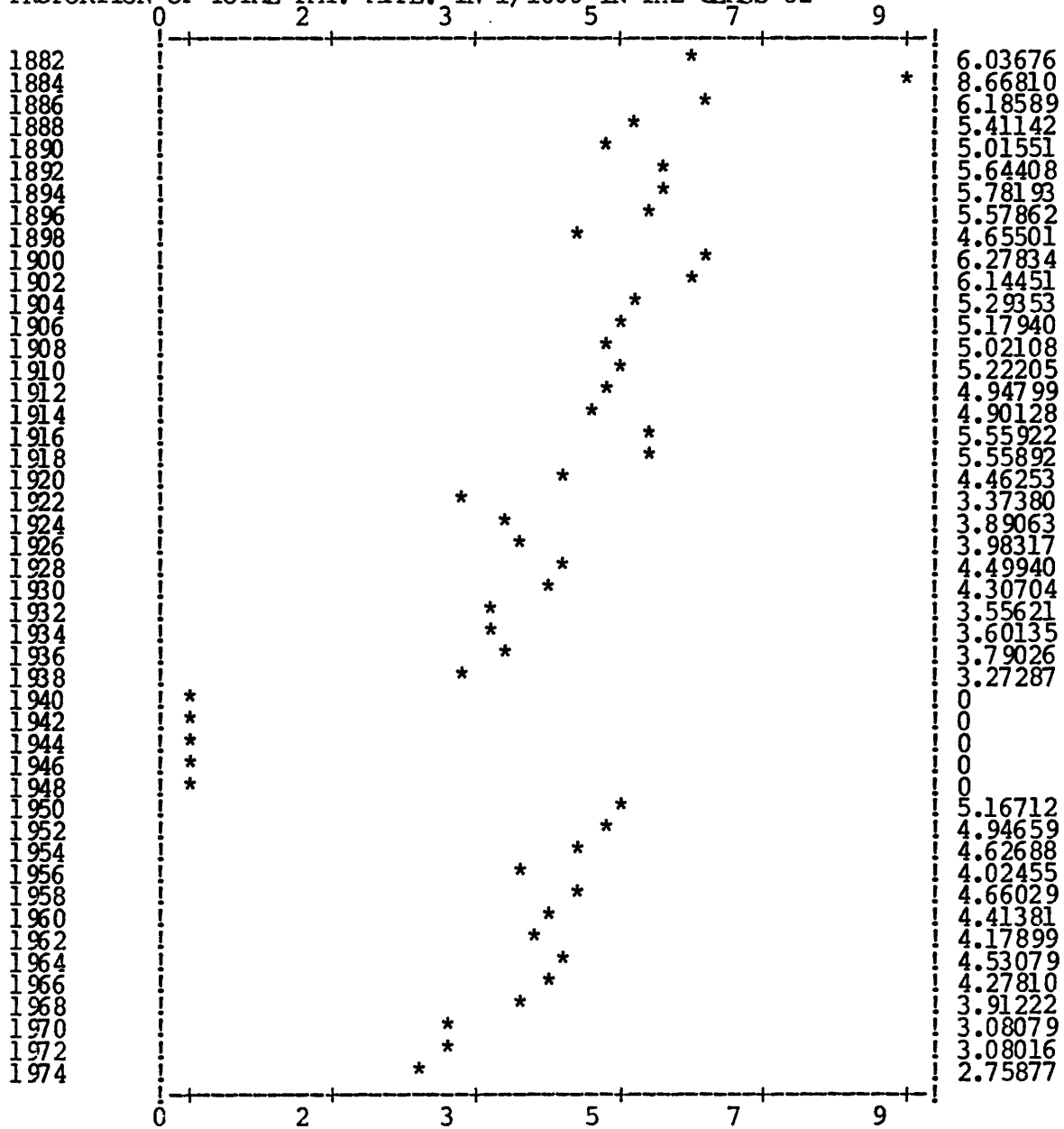

Cl. 83 Measurement of time

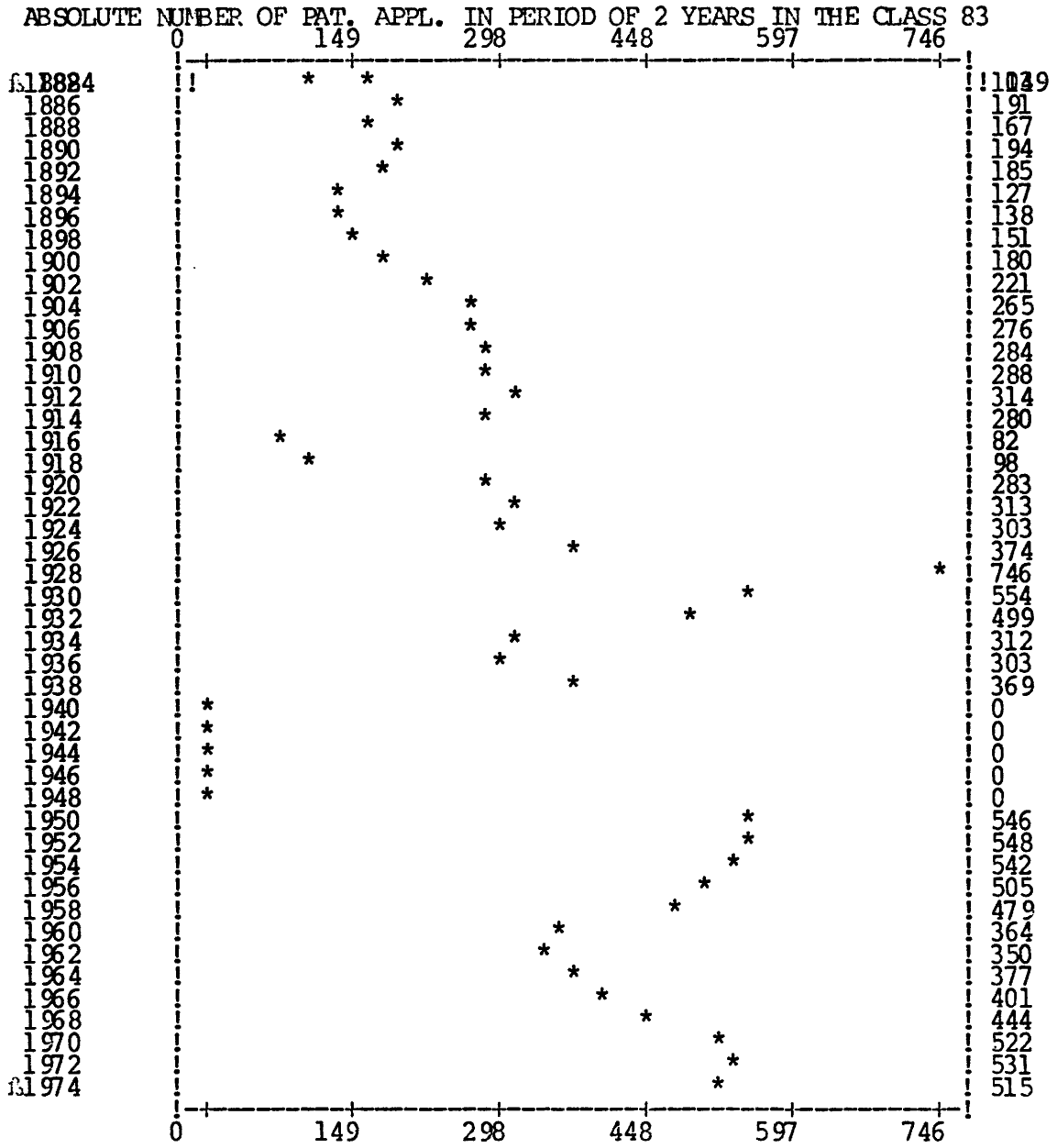

PROPORTION OF TOTAL PAT. APPL. IN 1/1000 IN THE CLASS 83

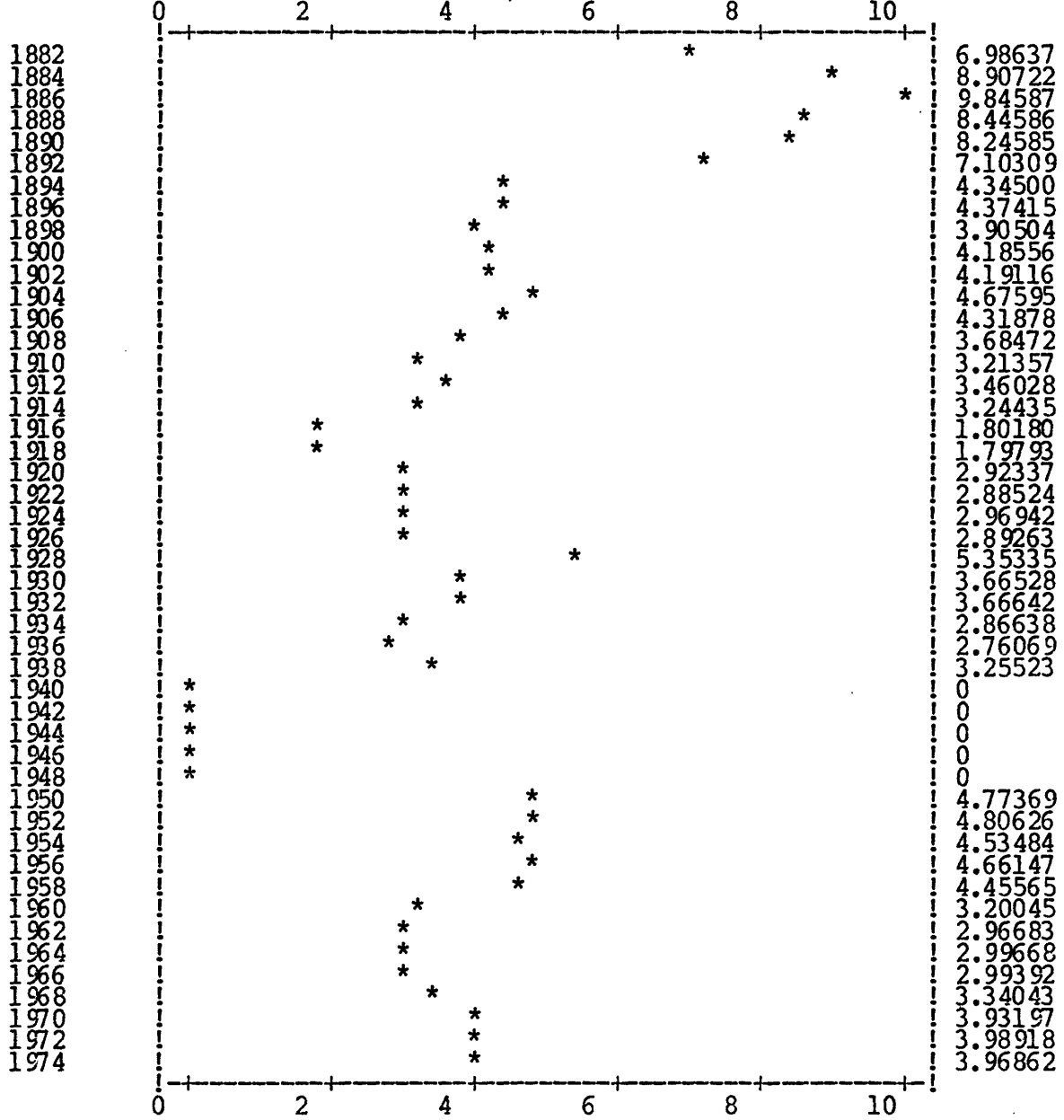



Cl. 84 Hydraulic engineering and foundations

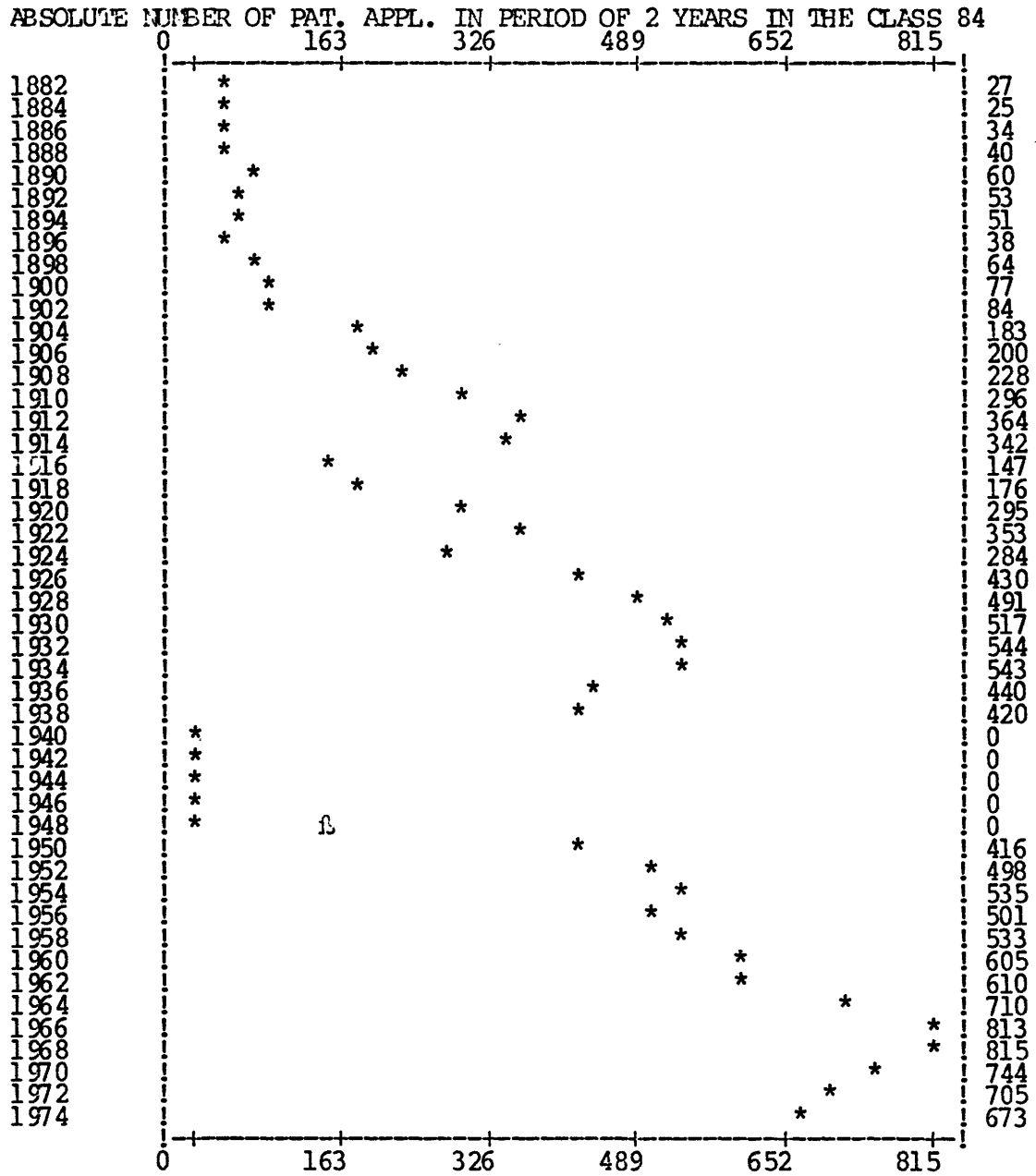

PROPORTION OF TOTAL PAT. APPL. IN 1/1000 IN THE CLASS 84

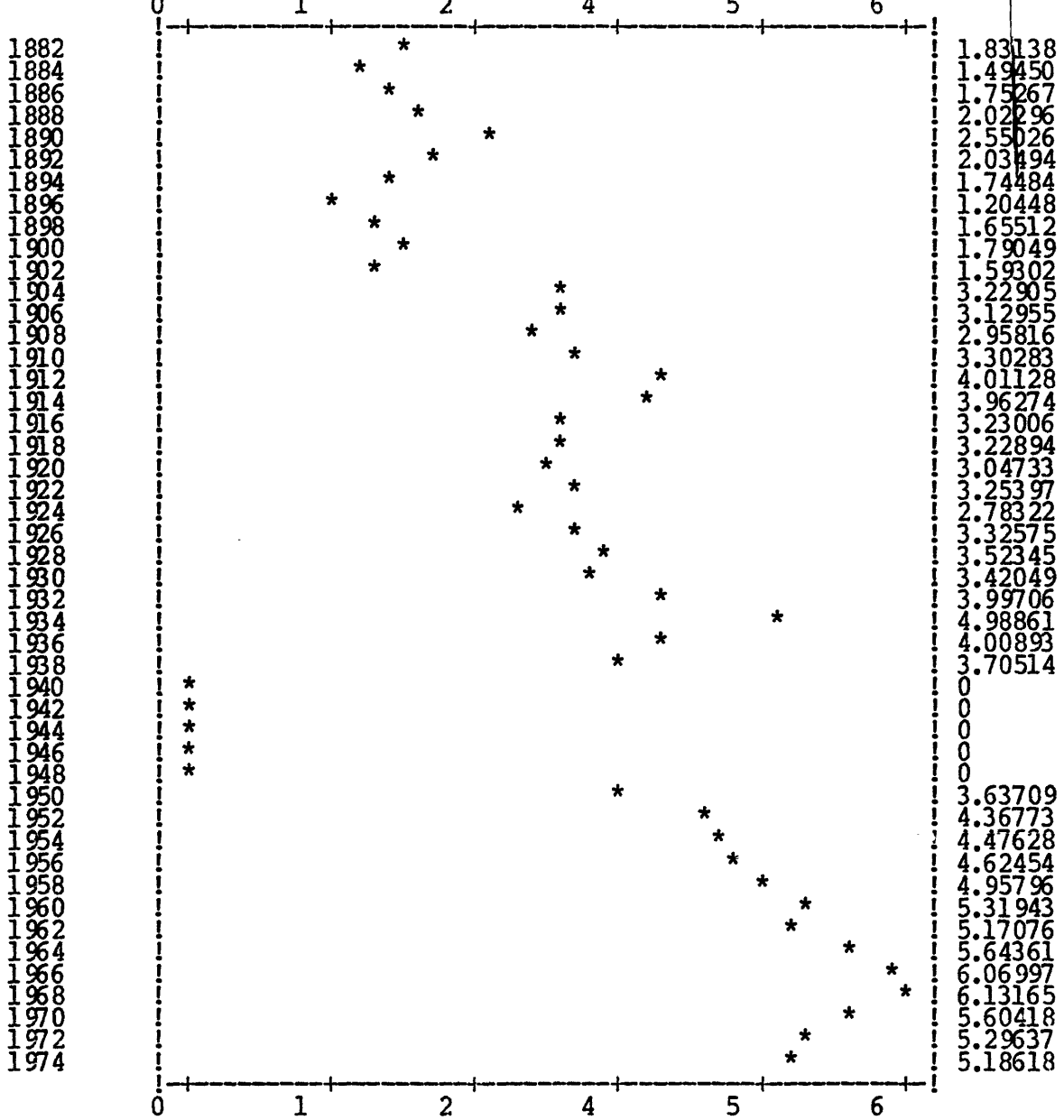

Cl. 85 Mineral and soda water, water purification, water supply and sewerage

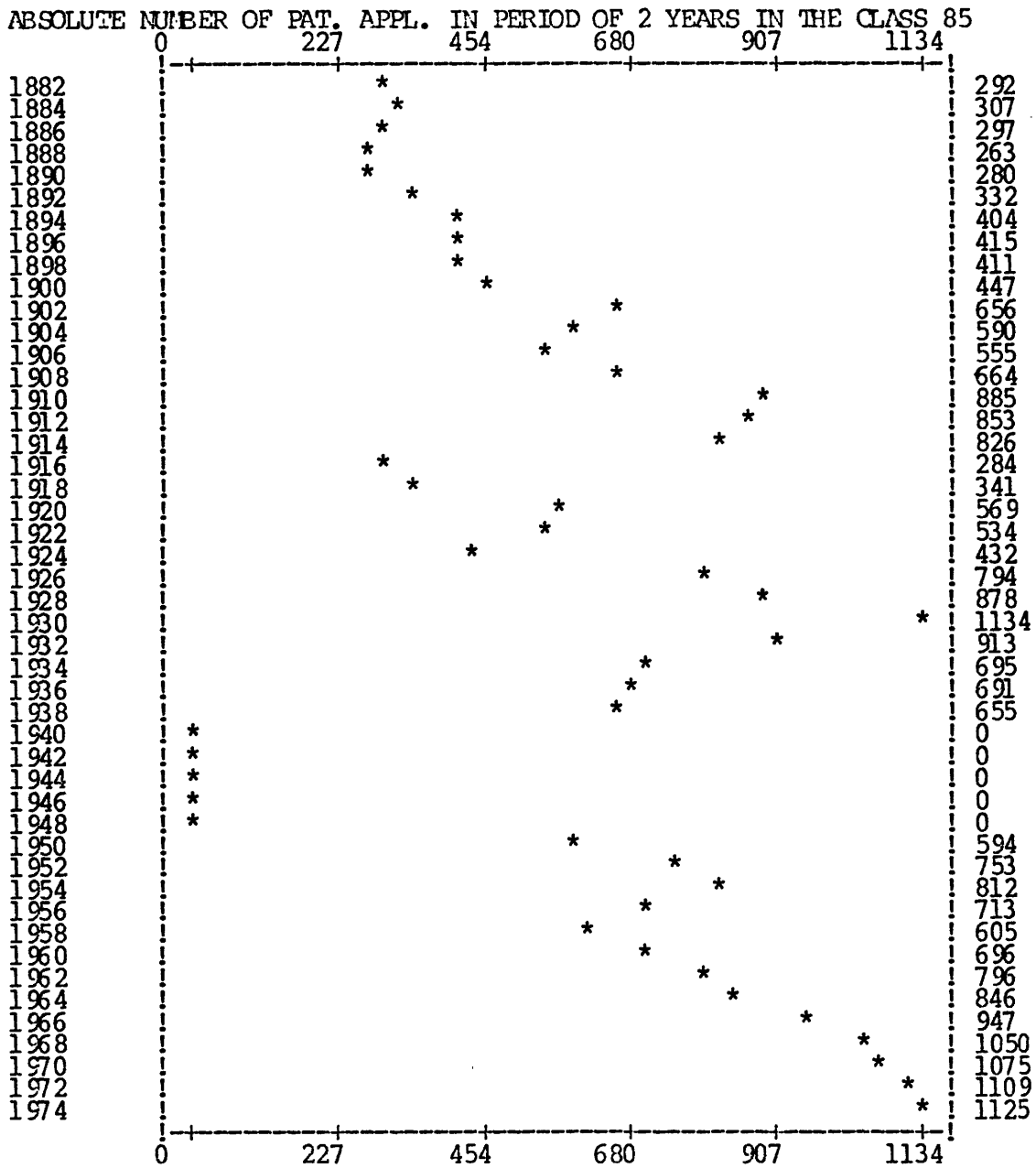

PROPORTION OF TOTAL PAT. APPL. IN 1/1000 IN THE CLASS 85

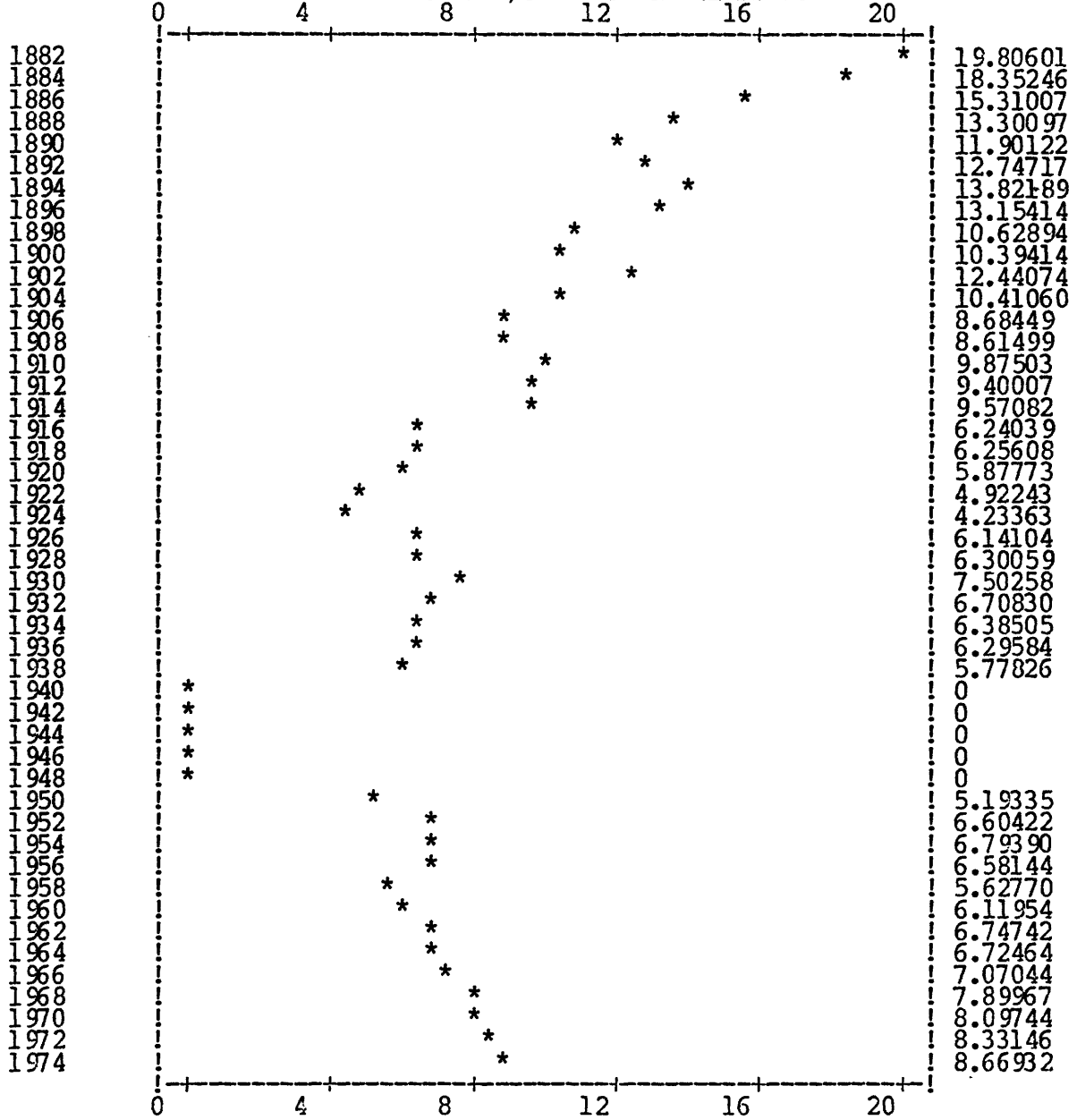

Cl. 86 Weaving

ABSOLUTE NUMBER OF PAT. APPL. IN PERIOD OF 2 YEARS IN THE CLASS 86

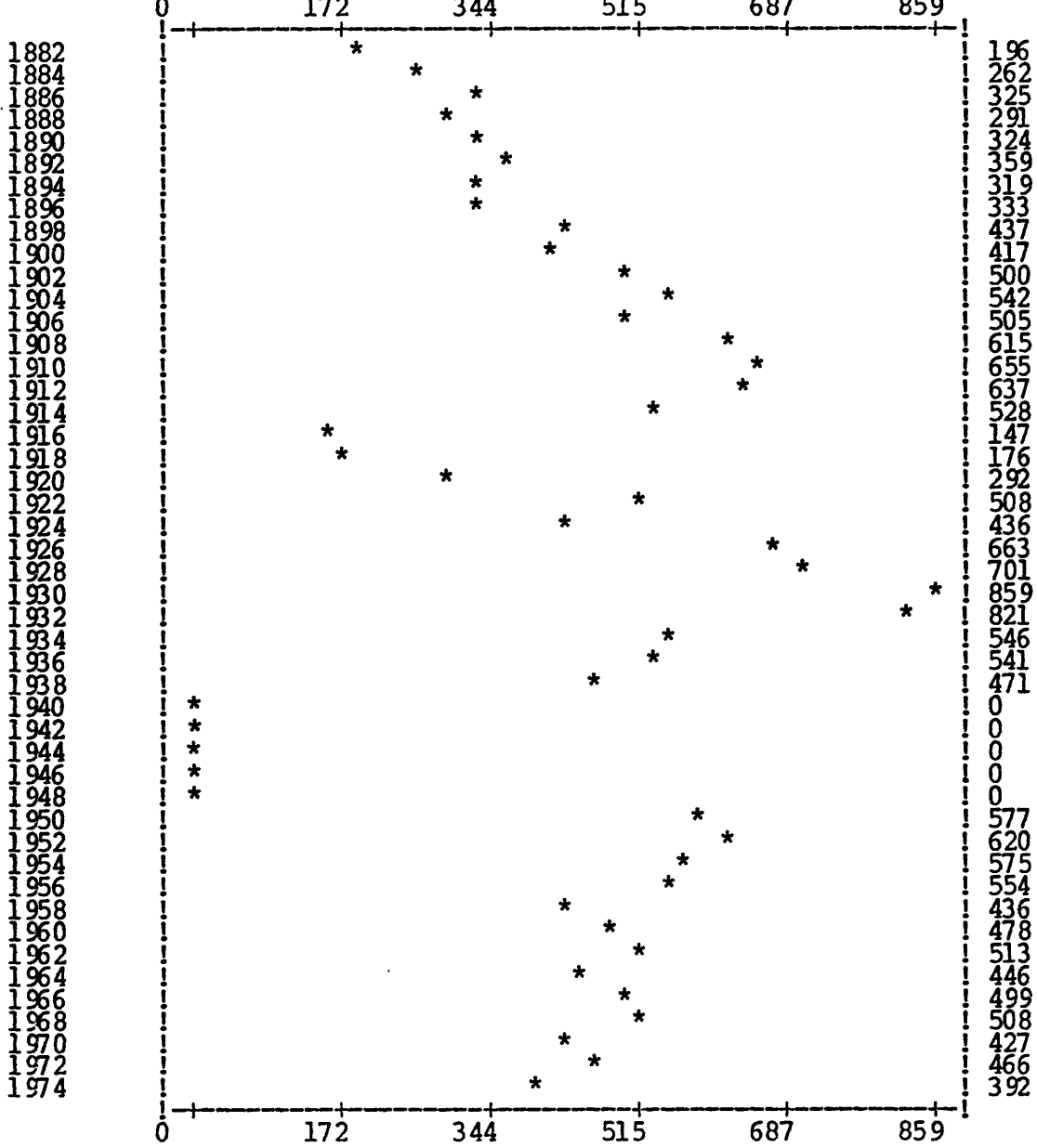

PROPORTION OF TOTAL PAT. APPL. IN 1/1000 IN THE CLASS 86

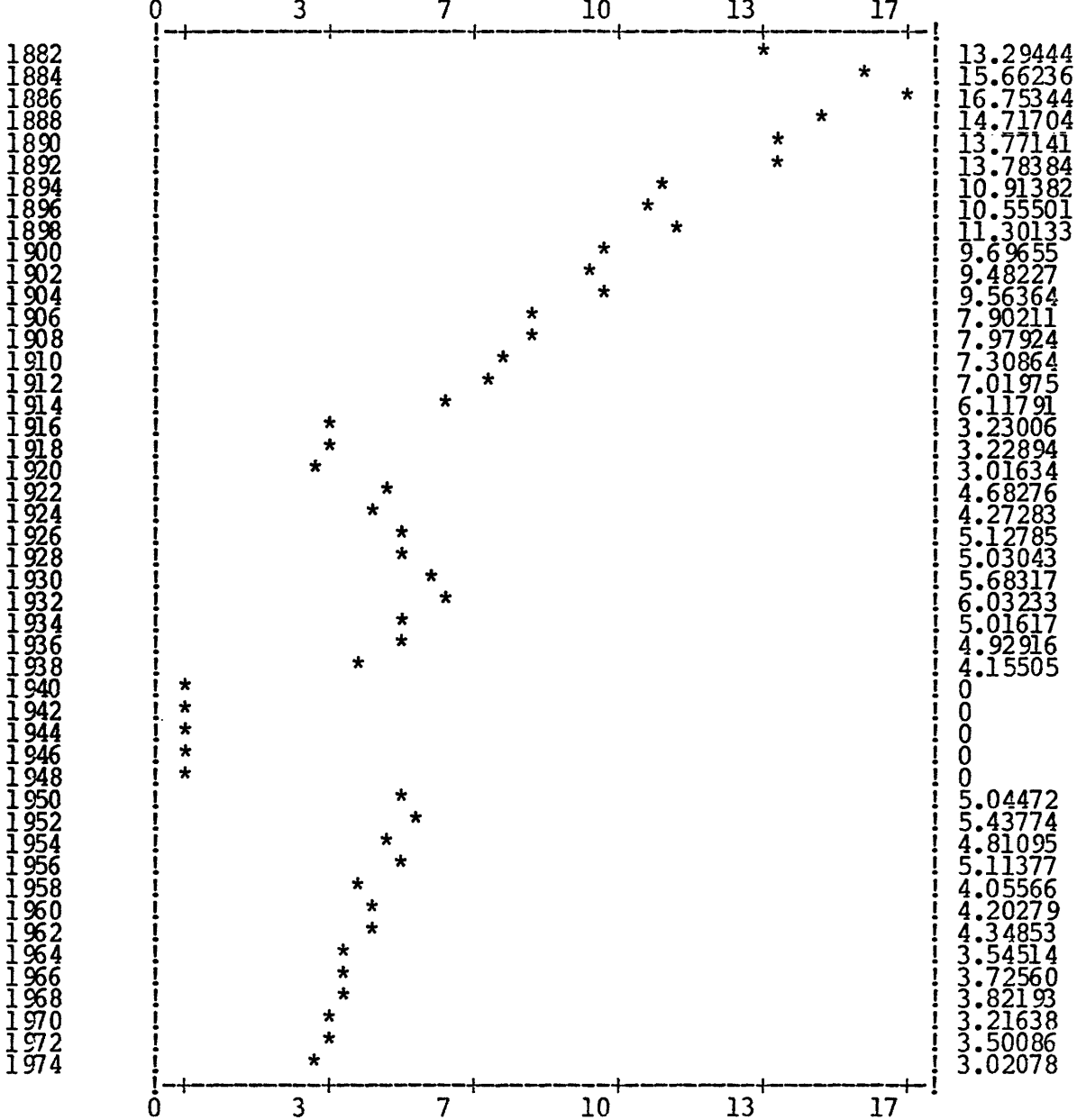

Cl. 87 Tools and implements, including pneumatic tools, for general purposes

ABSOLUTE NUMBER OF PAT. APPL. IN PERIOD OF 2 YEARS IN THE CLASS 87

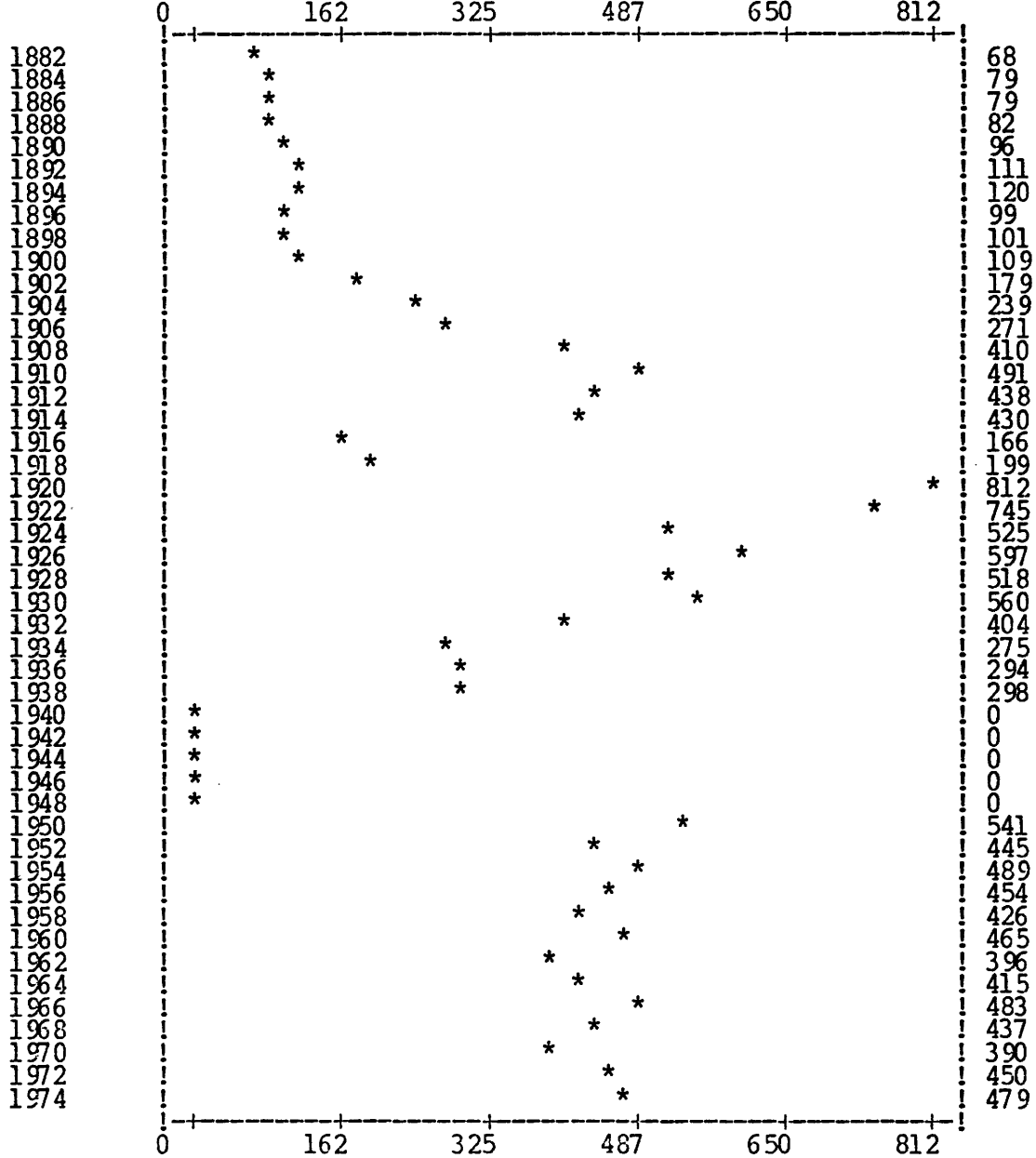

PROPORTION OF TOTAL PAT. APPL. IN 1/1000 IN THE CLASS 87

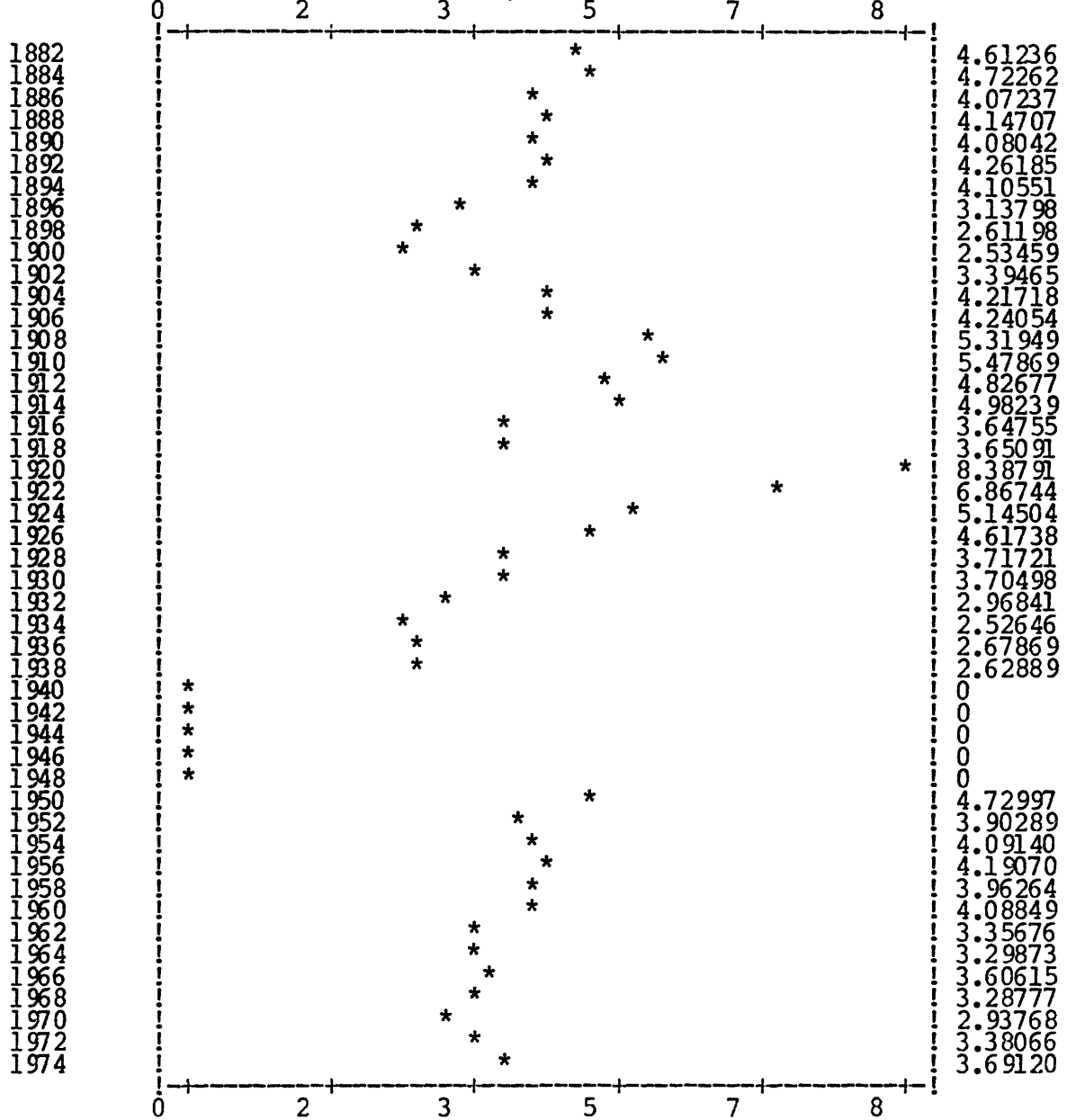



Cl. 88 Machines driven by wind or water power; electrophysical and nuclear reaction drives, photon drives

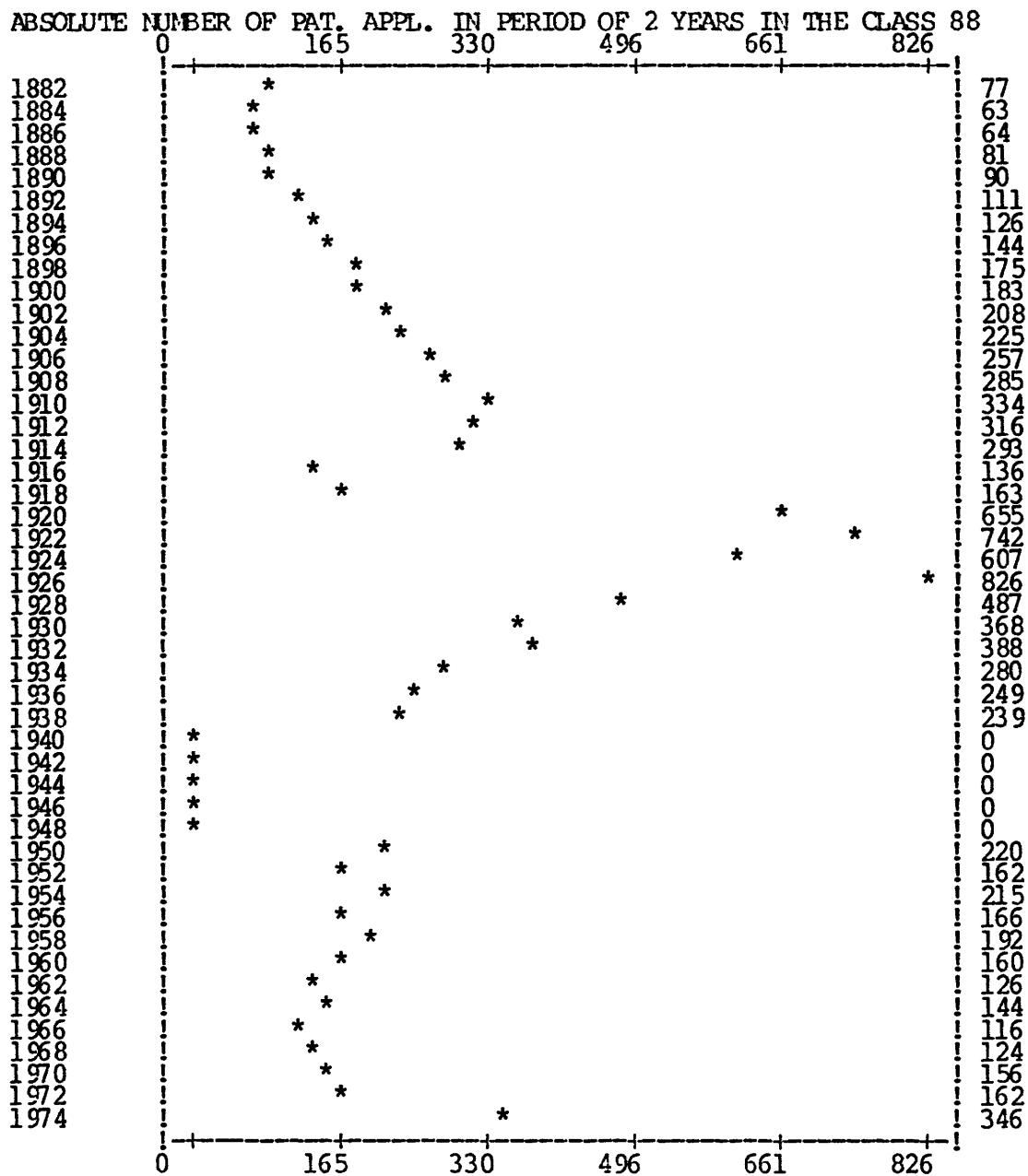

PROPORTION OF TOTAL PAT. APPL. IN 1/1000 IN THE CLASS 88

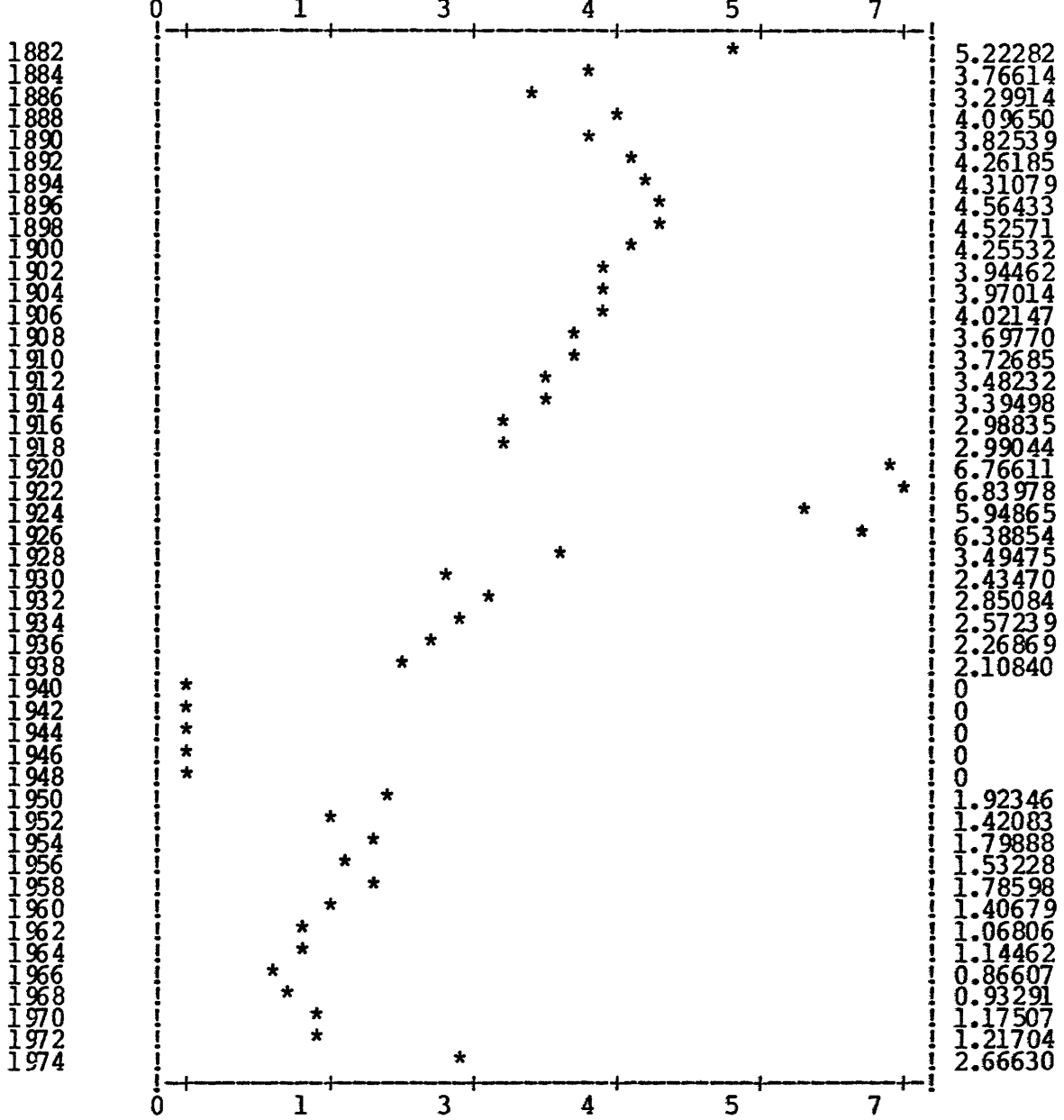

Cl. 89 Sugar and starch industry

ABSOLUTE NUMBER OF PAT. APPL. IN PERIOD OF 2 YEARS IN THE CLASS 89

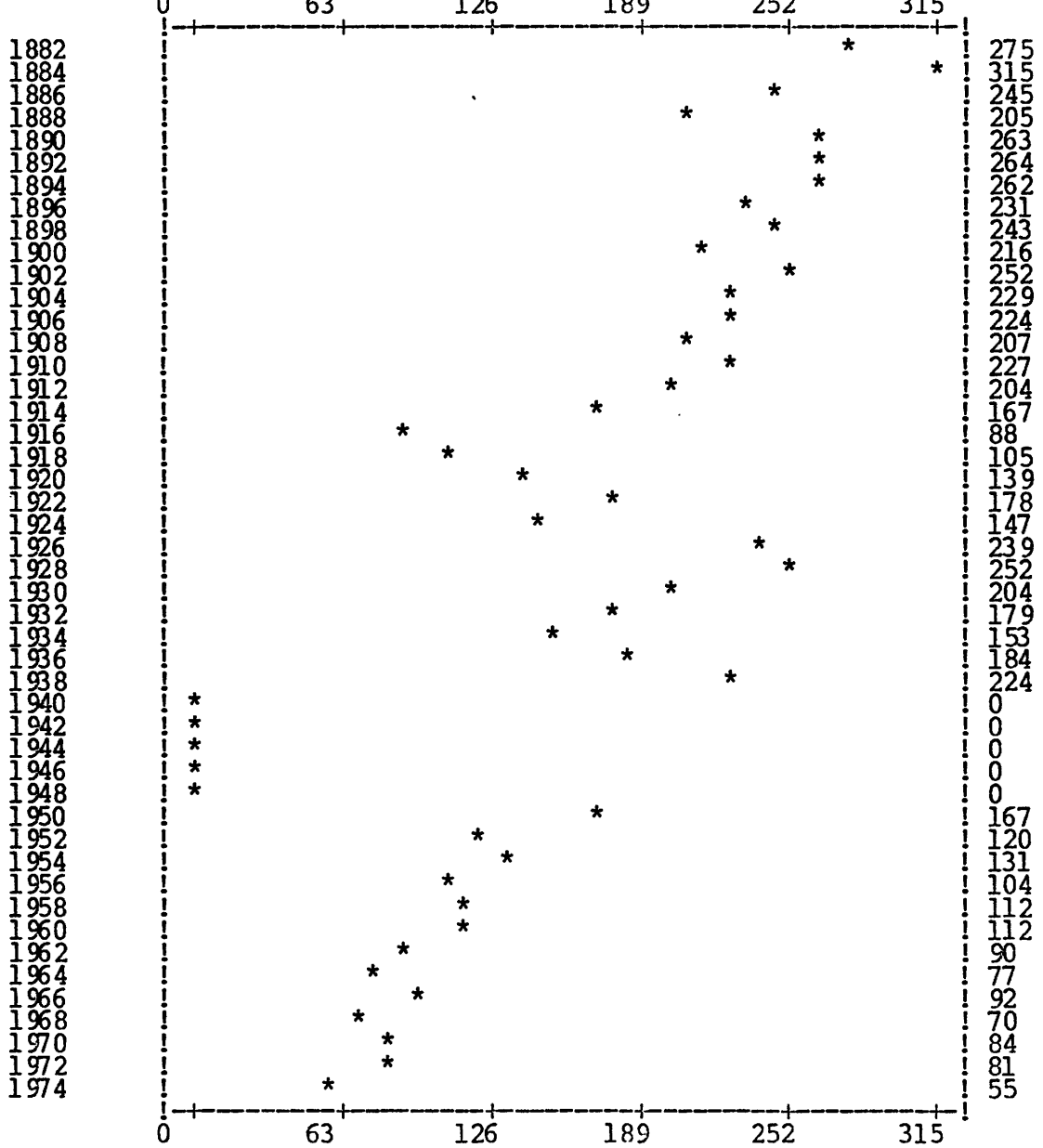

PROPORTION OF TOTAL PAT. APPL. IN 1/1000 IN THE CLASS 89

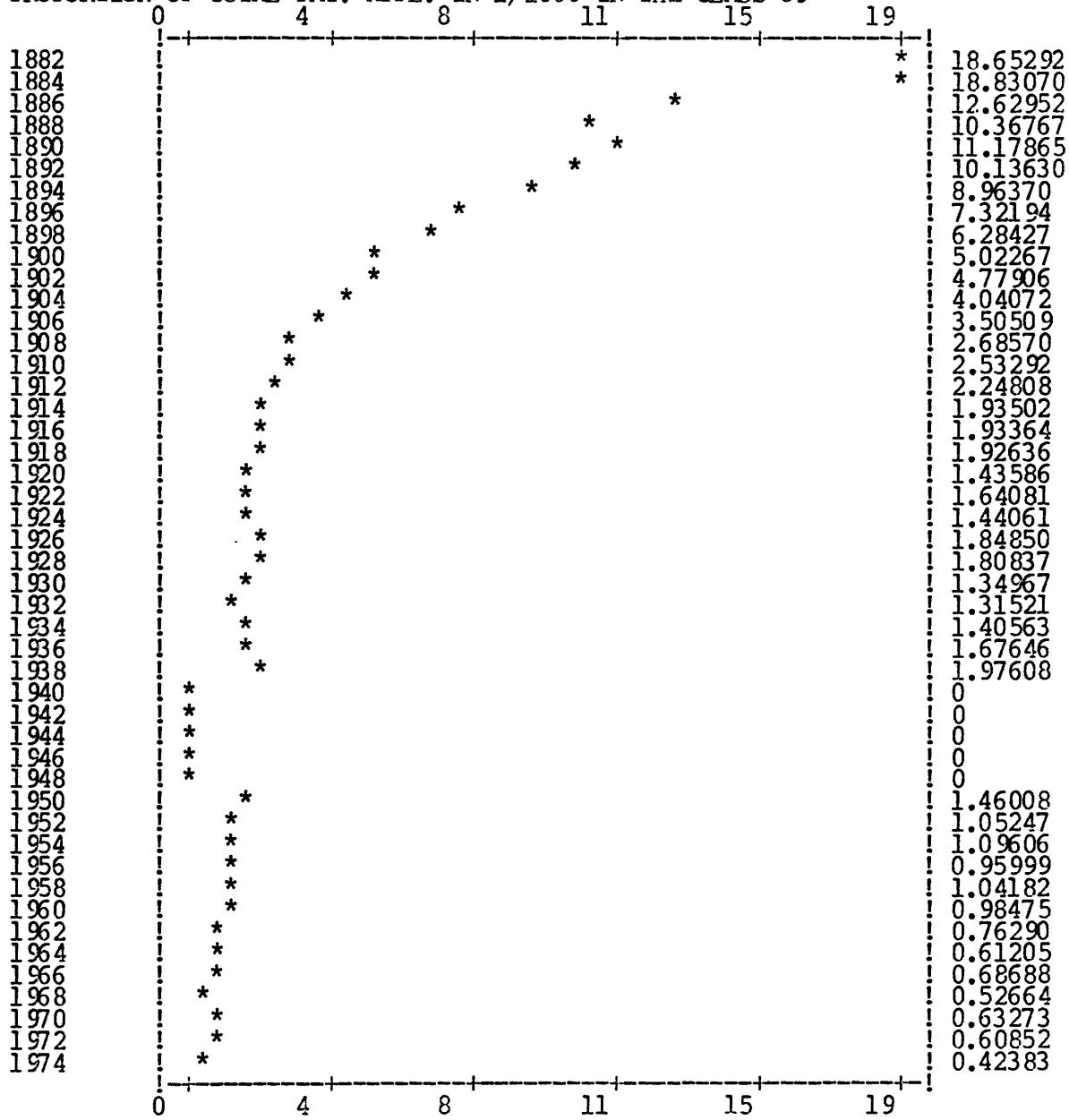

C. VON WITZLEBEN IN POTSDAM.

Schleuder zur Herstellung von Zucker-Prismen oder -Tafeln.

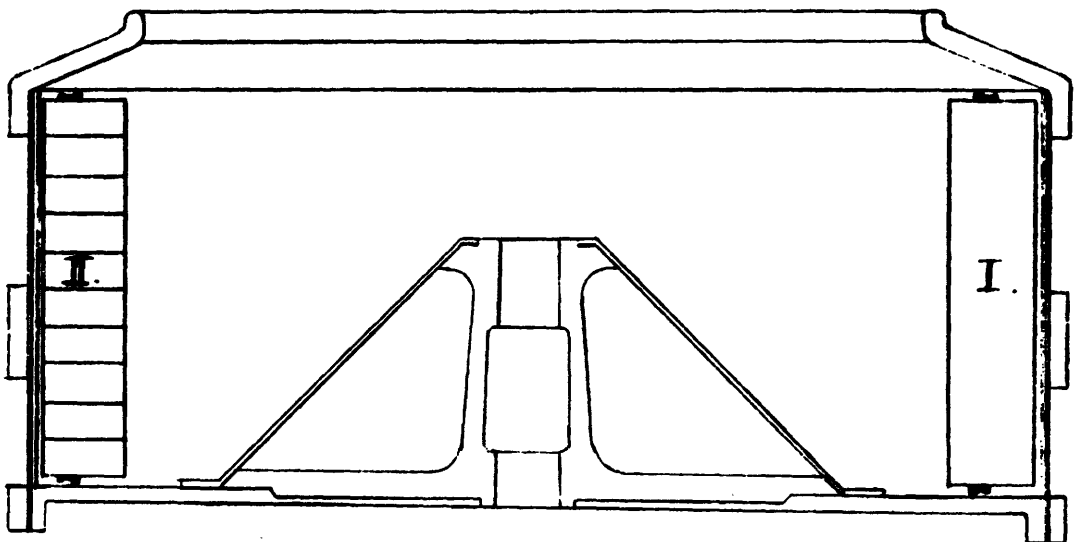

Zu der Patentschrift

№ 95.

PHOTOG. DRUCK DER KÖNIGL. PREUSS. STAATSDRUCKEREI.

#### 4. Patent Classes of the German Patent Classification (as of 1974)

PATENT CLASSES IN ACCORDANCE WITH  
THE GERMAN PATENT CLASSIFICATION  
(AS OF 1974)

- Cl. 1 Preparation of ores, fuels and other minerals, including waste and the residues of combustion
- Cl. 2 Baking
- Cl. 3 Wearing apparel
- Cl. 4 Lighting through fuels and pre-heating torches
- Cl. 5 Mining
- Cl. 6 Zymology : alcohol, spirits, beer, wine, vinegar, yeast and other fermentation agents and products, enzymes
- Cl. 7 Mechanical metal working without essentially removing material; punching metal
- Cl. 8 Bleaching, washing, dyeing, printing of cloth and tapestry and finishing
- Cl. 9 Brushwear
- Cl. 10 Fuels
- Cl. 11 Bookbinding, albums, files and special printed matter
- Cl. 12 Chemical processes and apparatus not included in other special classes
- Cl. 13 Steam boilers for power generation and related equipment, steaming capacity
- Cl. 14 Machines or engines in general, steam engines, power generating plant in general; periodic control, lubrication, exhaust devices or silencers for gases, cooling of machines or engines, particularly combustion engines

- Cl. 15 Printing, lining machines, typewriters, stamps
- Cl. 16 Manufacture of fertilizers
- Cl. 17 Refrigeration or cooling, storage of ice, heat transfer, liquefaction by mechanical means of gases or gas mixtures, e.g. air, which do not condense easily
- Cl. 18 Metallurgy of iron
- Cl. 19 Construction of roads, railways and bridges
- Cl. 20 Railway transport
- Cl. 21 Electrical engineering
- Cl. 22 Dyes; paints; polishes; natural resins; adhesives; miscellaneous compositions; miscellaneous applications of material
- Cl. 23 Oils and fats
- Cl. 24 Furnaces etc.
- Cl. 25 Braiding, lace-making, knitting, trimmings, non-woven fabrics
- Cl. 26 Production of gases by the degasification of fuels, e.g. natural gas and oil gas; production of gaseous fuels by liquid processes; production of gaseous fuels by carburation; distillation gas and acetylene cleaning
- Cl. 27 Fans, air pumps and compressors
- Cl. 28 Tanning and treatment of skins and hides, leather industry
- Cl. 29 Yarns
- Cl. 30 Medical science
- Cl. 31 Industrial furnaces; casting; powder metallurgy
- Cl. 32 Glass; mineral and slag wool
- Cl. 33 Hand and travelling articles
- Cl. 34 Furniture; domestic articles or appliances; suction cleaners in general
- Cl. 35 Lifting gear (lifts, cranes, winches, hoists)
- Cl. 36 Heating, ventilation, hot water supply in buildings
- Cl. 37 Building
- Cl. 38 Wood working by mechanical and chemical means



- Cl. 39 Working of plastic masses, rubber and horny materials not otherwise provided for; products of polycondensation, polyaddition and polymerization
- Cl. 40 Metallurgy other than of iron; alloys including ferrous alloys
- Cl. 41 Headwear; felts
- Cl. 42 Instruments
- Cl. 43 Checking devices, cash machines and post sorting machines
- Cl. 44 Habadashery, jewellery; snuff takers and smokers' requisites
- Cl. 45 Agriculture and forestry; animal husbandry; hunting and trapping; fishing
- Cl. 46 Combustion engines; hot-gas or combustion-product engine plants
- Cl. 47 Engineering elements or units; general measures for producing and maintaining effective functioning of machines or installations; details of instruments
- Cl. 48 Working and treatment of metals other than by mechanical means
- Cl. 49 Machine tools, metal working not otherwise provided for
- Cl. 50 Grinding and pulverizing including preparatory processes, subsequent treatment of the ground materials by sieving and mixing and separation of matter from the air
- Cl. 51 Musical instruments
- Cl. 52 Sewing and embroidering
- Cl. 53 Foods and foodstuffs not included in special classes, feeding stuffs
- Cl. 54 Working of paper and board and products thereof as well as advertising material
- Cl. 55 Production of cellulose, paper and board
- Cl. 56 Upholstery and saddlery
- Cl. 57 Photography, cinematography and sound film
- Cl. 58 Presses
- Cl. 59 Fluid pumps and other hydraulic lifting devices
- Cl. 60 Fluid-pressure actuators; hydraulics and pneumatics
- Cl. 61 Life-saving and fire-fighting
- Cl. 62 Aviation, air cushion vehicles, cosmonautics

- Cl. 63 Trackless vehicles
- Cl. 64 Distribution of alcoholic liquors
- Cl. 65 Ships and other waterborne vehicles; related equipment
- Cl. 66 Butchering and meat treatment
- Cl. 67 Grinding and polishing
- Cl. 68 Articles of the locksmithing trade
- Cl. 69 Cutting tools including cutting and stabbing weapons; domestic cutting appliances and machines
- Cl. 70 Writing and drawing appliances
- Cl. 71 Footwear
- Cl. 72 Fire arms, ammunition, fortifications
- Cl. 73 Ropes
- Cl. 74 Signalling
- Cl. 75 Sculpture, painting, ornamentation of surfaces
- Cl. 76 Spinning
- Cl. 77 Sports, games and amusements
- Cl. 78 Explosives, matches, fireworks, flashlight, production of artificial fog
- Cl. 79 Tobacco, cigars, cigarettes
- Cl. 80 Clay articles, stones, chalk, cement, plaster, asphalt, briquette presses
- Cl. 81 Transport and packing
- Cl. 82 Drying including drying kilns, coffee roasters, centrifugal apparatus for general purposes
- Cl. 83 Measurement of time
- Cl. 84 Hydraulic engineering and foundations
- Cl. 85 Mineral and soda water, water purification, water supply and sewerage
- Cl. 86 Weaving
- Cl. 87 Tools and implements, including pneumatic tools, for general purposes

C1. 88 Machines driven by wind or water power; electrophysical and nuclear reaction drives, photon drives

C1. 89 Sugar and starch industry

SUBJECT INDEX

## SUBJECT INDEX

Basic innovations	31, 38-42, 46, 48, 88, 113
Basic process innovations	42
Behaviour patterns	1
Changes (of the classification)	8, 11, 40, 43, 44, 56, 78, 79, 87, 88
Classification of patents	7-11, 57, 70, 71, 75, 77, 111
Economic aspects	27
Economic crisis	7, 70, 89, 95
Economic demand for innovations	33
Economic pressure	32, 38
Endogenous factors	1, 29, 30, 94, 95, 97, 101, 102
Exhaustion of technical potential	29, 30, 32, 46, 55-57, 70, 90, 94, 95, 111
Exogenous factors	1, 29, 30, 94, 95, 101, 102
First World War	42, 69, 71-74, 77, 88, 94
Foreigners	25, 78, 111, 113
Funds available	28, 33
German classification	57
Homogeneity of patent classes	10
Hypotheses	31
Innovation life cycle	46, 47
Innovation theory	40
International classification	9, 11, 57
Invention	7, 9, 27, 39, 41, 43-46, 48, 69, 109
Linear spline function	55
Logistic curve	46, 47, 90, 96
Logistic function	55-57, 68, 69, 71, 75, 76, 103
Logistic S function	30
Long-term, short-term	2, 88

Nationals	25, 46, 78, 111
Number of Patent Applications	10, 11, 25, 28, 31, 42, 45, 56, 57, 66-74, 78-83, 88-90, 94-97, 111
Patent applications	1, 7-11, 25-29, 31, 42, 45, 46, 55-57, 68-75, 77-79, 87-91, 94-97, 101-104
Patent law	7, 42, 45, 101, 111
Patent Office	7, 8, 11, 42-44, 101, 109-112
Patent protection	7, 71
Patent statistics	25, 43-45, 101, 109-111
Process-orientated classes	9
Product-orientated classes	9
Propensity to patent inventions	44
Raw-material-orientated classes	9
Rival area	32
Second World War	42, 69-74, 77, 79, 80, 86-89, 94
Spline Function	55, 77, 79, 80
Step function	30, 43, 71
Structural development	1
Technological predictions	26
Technological revolution	29, 30
Theory of inventions	25
Trend function	79-81, 86, 103
Trends in patent applications	10, 25-27, 31, 55, 56, 69, 75, 77, 78, 88-91, 94-97, 101-103, 109, 110

European Communities — Commission

**EUR 11044 — One century of technical progress,  
based on an analysis of German patent statistics**

*J. Sláma*

Luxembourg: Office for Official Publications of the European Communities

1987 — IV, 365 pp., 163 fig. — 21.0 × 29.7 cm

Information management series

EN

ISBN 92-825-7483-0

Catalogue number: CD-NA-11044-EN-C

Price (excluding VAT) in Luxembourg

ECU 27.90    BFR 1 200    IRL 21.60    UKL 19.80    USD 31.70

This study looks at trends in patent applications in Germany and the Federal Republic of Germany in the last 100 years.

The main aims of the analysis of these data are as follows:

1. Using the time series of patent applications, trends in the production of technological know-how are described for various sectors.
2. On the basis of trends in patent applications, the typical behaviour patterns in technological development are identified and a number of hypotheses regarding behaviour in the technology sector are formulated and tested.
3. On the basis of the analysis of trends in patent applications, the influence of exogenous (i.e. economic, social, etc.) and endogenous (i.e. relating to science and its laws) factors on technology is determined.
4. In addition, the patterns of structural development of the technology sectors are determined and the structural influences of technological change on the trends in patent applications as a whole are identified.
5. On the basis of the analysis of patent applications, the relationship between long- and short-term trends and fluctuations in the economy and economic development are shown in relation to technological development.
6. On the basis of the statistical analysis of the time series of patent applications, the time sequence of the technology sectors is determined in relation to their growth — both in qualitative and in quantitative terms.

**Venta y suscripciones · Salg og abonnement · Verkauf und Abonnement · Πωλήσεις και συνδρομές  
Sales and subscriptions · Vente et abonnements · Vendita e abbonamenti  
Verkoop en abonnementen · Venda e assinaturas**

**BELGIQUE/BELGIË**

**Moniteur belge/Belgisch Staatsblad**  
Rue de Louvain 40-42/Leuvensestraat 40-42  
1000 Bruxelles/1000 Brussel  
Tél. 512 00 26  
CCP/Postrekening 000-2005502-27

Sous-dépôts/Agentschappen:

**Librairie européenne/  
Europese Boekhandel**

Rue de la Loi 244/Wetstraat 244  
1040 Bruxelles/1040 Brussel

**CREDOC**

Rue de la Montagne 34/Bergstraat 34  
Bte 11/Bus 11  
1000 Bruxelles/1000 Brussel

**DANMARK**

**Schultz EF-publikationer**

Møntergade 19  
1116 København K  
Tlf: (01) 14 11 95  
Telecopier: (01) 32 75 11

**BR DEUTSCHLAND**

**Bundesanzeiger Verlag**

Breite Straße  
Postfach 10 80 06  
5000 Köln 1  
Tel. (02 21) 20 29-0  
Fernschreiber: ANZEIGER BONN 8 882 595  
Telecopierer: 20 29 278

**GREECE**

**G.C. Eleftheroudakis SA**

International Bookstore  
4 Nikis Street  
105 63 Athens  
Tel. 322 22 55  
Telex 219410 ELEF

Sub-agent for Northern Greece:

**Molho's Bookstore**

The Business Bookshop  
10 Tsimiski Street  
Thessaloniki  
Tel. 275 271  
Telex 412885 LIMO

**ESPAÑA**

**Boletín Oficial del Estado**

Trafalgar 27  
28010 Madrid  
Tel. (91) 446 60 00

**Mundi-Premsa Libros, S.A.**

Castelló 37  
28001 Madrid  
Tel. (91) 431 33 99 (Libros)  
431 32 22 (Suscripciones)  
435 36 37 (Dirección)  
Télex 49370-MPLI-E

**FRANCE**

**Journal officiel**  
**Service des publications  
des Communautés européennes**  
26, rue Desaix  
75727 Paris Cedex 15  
Tél. (1) 45 78 61 39

**IRELAND**

**Government Publications Sales Office**

Sun Alliance House  
Molesworth Street  
Dublin 2  
Tel. 71 03 09

or by post

**Government Stationery Office  
Publications Section**

6th floor  
Bishop Street  
Dublin 8  
Tel. 78 16 66

**ITALIA**

**Licosa Spa**

Via Lamarmora, 45  
Casella postale 552  
50 121 Firenze  
Tel. 57 97 51  
Telex 570466 LICOSA I  
CCP 343 509

Subagenti:

**Libreria scientifica Lucio de Biasio - AEIOU**

Via Meravigli, 16  
20 123 Milano  
Tel. 80 76 79

**Libreria Tassi**

Via A. Farnese, 28  
00 192 Roma  
Tel. 31 05 90

**Libreria giuridica**

Via 12 Ottobre, 172/R  
16 121 Genova  
Tel. 59 56 93

**GRAND-DUCHÉ DE LUXEMBOURG  
et autres pays/and other countries**

**Office des publications officielles  
des Communautés européennes**

2, rue Mercier  
L-2985 Luxembourg  
Tél. 49 92 81  
Télex PUBOF LU 1324 b  
CCP 19190-81  
CC bancaire BIL 8-109/6003/200

Abonnements/Subscriptions

**Messageries Paul Kraus**

11, rue Christophe Plantin  
L-2339 Luxembourg  
Tél. 49 98 888  
Télex 25 15  
CCP 49242-63

**NEDERLAND**

**Staatsdrukkerij- en uitgeverijbedrijf**

Christoffel Plantijnstraat  
Postbus 20014  
2500 EA 's-Gravenhage  
Tel. (070) 78 98 80 (bestellingen)

**PORTUGAL**

**Imprensa Nacional  
Casa da Moeda, E. P.**

Rua D. Francisco Manuel de Melo, 5  
1092 Lisboa Codex  
Tel. 69 34 14  
Telex 15328 INCM

**Distribuidora Livros Bertrand Lda.**

**Grupo Bertrand, SARL**

Rua das Terras dos Vales, 4-A  
Apart. 37  
2700 Amadora CODEX  
Tel. 493 90 50 - 494 87 88  
Telex 15798 BERDIS

**UNITED KINGDOM**

**HM Stationery Office**

HMSO Publications Centre  
51 Nine Elms Lane  
London SW8 5DR  
Tel. (01) 211 56 56

Sub-agent:

**Alan Armstrong & Associates Ltd**

72 Park Road  
London NW1 4SH  
Tel. (01) 723 39 02  
Telex 297635 AAALTD G

**UNITED STATES OF AMERICA**

**European Community Information  
Service**

2100 M Street, NW  
Suite 707  
Washington, DC 20037  
Tel. (202) 862 9500

**CANADA**

**Renouf Publishing Co., Ltd**

61 Sparks Street  
Ottawa  
Ontario K1P 5R1  
Tel. Toll Free 1 (800) 267 4164  
Ottawa Region (613) 238 8985-6  
Telex 053-4936

**JAPAN**

**Kinokuniya Company Ltd**

17-7 Shinjuku 3-Chome  
Shiniuku-ku  
Tokyo 160-91  
Tel. (03) 354 0131

**Journal Department**

PO Box 55 Chitose  
Tokyo 156  
Tel. (03) 439 0124



## NOTICE TO THE READER

All scientific and technical reports published by the Commission of the European Communities are announced in the monthly periodical '**euro abstracts**'. For subscription (1 year: BFR 3 300) please write to the address below.

Price (excluding VAT) in Luxembourg  
ECU 27.90 BFR 1 200 IRL 21.60 UKL 19.80 USD 31.70



OFFICE FOR OFFICIAL PUBLICATIONS  
OF THE EUROPEAN COMMUNITIES

L— 2985 Luxembourg

ISBN 92-825-7483-0



9 789282 574836