

Operation and Utilisation of the High Flux Reactor

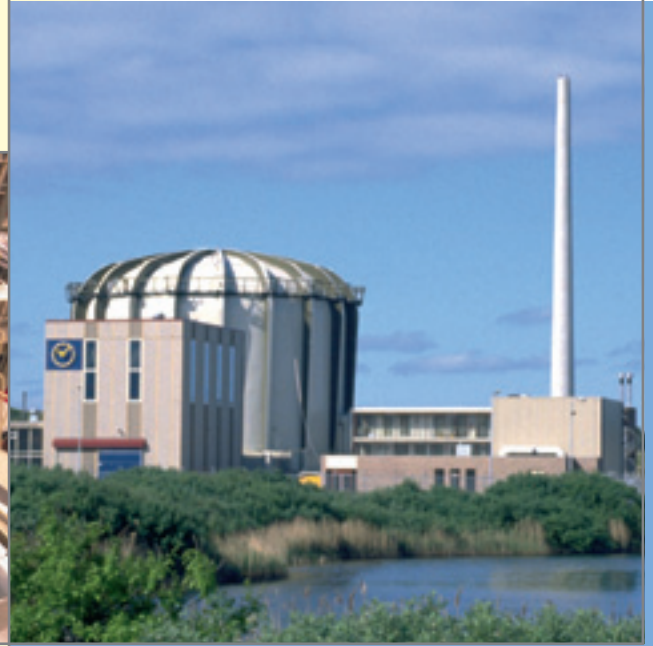

Annual Report 2007

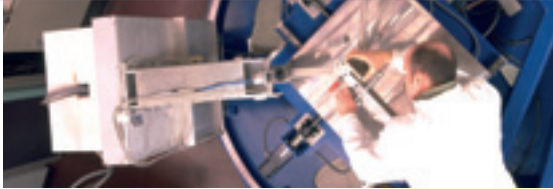
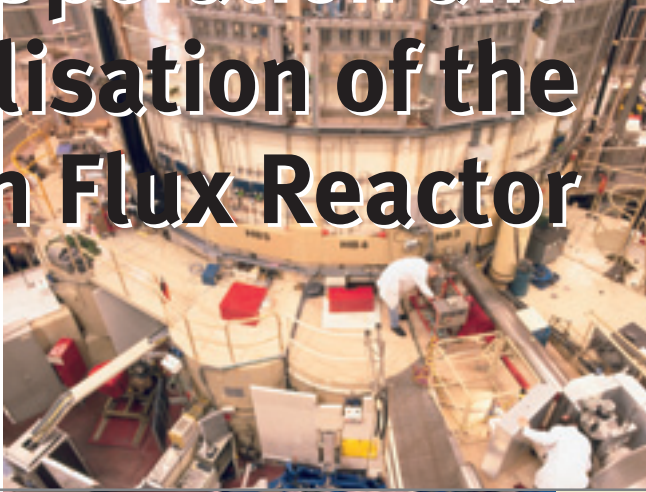

EUR 23421 EN

Mission of the Institute for Energy

The Institute for Energy provides scientific and technical support for the conception, development, implementation and monitoring of community policies related to energy. Special emphasis is given to the security of energy supply and to sustainable and safe energy production.

European Commission

Joint Research Centre (DG JRC)
Institute for Energy
Petten
The Netherlands

Contact:

Tel. switchboard	+31-224-565656
High Flux Reactor	+31-224-565151
Public Relations & Communication	+31-224-565278
http://ie.jrc.ec.europa.eu/	
http://www.jrc.ec.europa.eu/	

Legal notice

Neither the European Commission nor any person acting on behalf of the Commission is responsible for the use which might be made of this publication.

A great deal of additional information on the European Union is available on the internet. It can be accessed through the Europa server (<http://europa.eu>).

Luxembourg: Office for Official Publications of the European Communities, 2008

European Commission

EUR 23421 EN
ISSN 1018-5593
DOI 10.2790/156
ISBN 978-92-79-09116-2

© European Communities, 2008

Reproduction is authorised provided the source is acknowledged.

Printed in the Netherlands, Aranea Grafimedia

Table of contents

Introduction	2
HFR: Reactor Management	3
HFR Operation and Related Services	3
Renewal of Nuclear Infrastructure	6
Fuel Cycle	8
Visits and Visitors	9
HFR: The Programmes	10
European Network AMES and SAFELIFE	10
Safety of Innovative Reactor Designs (SAFETY-INNO)	12
High Temperature Reactor Technology Network - HTR-TN	13
Network on Neutron Techniques Standardisation for Structural Integrity - NET	14
HFR as a Tool for Research	16
Neutron Beam Research	16
Medical Applications	18
Boron Neutron Capture Therapy - BNCT	18
Medical Radio-isotope Production	23
Fission Reactor Technology	24
High Temperature Reactor Fuel Irradiations	24
HTR Core Structures Graphites	26
Irradiation of HTR Vessel Material and Post-Irradiation Test	27
Fusion Reactor Technology	28
ITER Vessel/In-Vessel	28
Sub-modules for the Helium Cooled Pebble Bed Concept	29
Functional Fusion Blanket Materials	29
Structural Steel for ITER Test Blankets	30
Advanced Materials	30
Partitioning and Transmutation Technologies	32
Fuel Transmutation	32
ADS Material development	34
Neutron Transmutation Doping of Silicon	34
List of Authors, Glossary	35-36

Introduction

The High Flux Reactor (HFR) Petten, managed by the Institute for Energy (IE) of the JRC of the European Commission, is one of the most powerful multi-purpose materials testing reactors in the world. The HFR is of the tank-in-pool type, light water cooled and moderated and operated at 45 MW. In operation since 1961, and following a new vessel replacement in 1984, the HFR has a technical life beyond the year 2015. The reactor provides a variety of irradiation facilities and possibilities in the reactor core, in the reflector region and in the poolside. Horizontal beam tubes are available for research with neutrons and gamma irradiation facilities are also available. Furthermore, excellently equipped hot cell laboratories on the Petten site provide virtually all possibilities envisaged for post-irradiation examinations. The close co-operation between JRC and NRG on all aspects of nuclear research and technology is essential to maintain the key position of the HFR amongst research reactors world-

wide. This co-operation has led to a unique HFR structure, in which both organisations are involved. JRC is the owner of the plant (for a lease of 99 years) and the plant and budget manager. JRC develops a platform around HFR as a tool for European collaborative programmes. NRG operates and maintains the plant, under contract, for JRC and, since the 2000/2003 programme, manages the commercial activities around the reactor. As of February 2005 NRG has become the holder of the operation licence granted under the Dutch Nuclear Energy Law. Furthermore each organisation provides complementary possibilities around the reactor activities, such as the hot cell facilities of NRG or the experiment commissioning laboratory of JRC. HFR is also in the core of the Medical Valley association. This association between IE, NRG, Tyco, Urenco and hospitals leads to a Centre of Excellence, unique in Europe.

During the last three decades the HFR has been operated from Supplementary Programmes regularly discussed by the European Council. The JRC and its current and future partners are exploring longer term engagements for a more sustainable future for the HFR. The objective should be to broaden the partnership for the HFR and in particular to allow national and private research centres to join in the operation of the HFR.

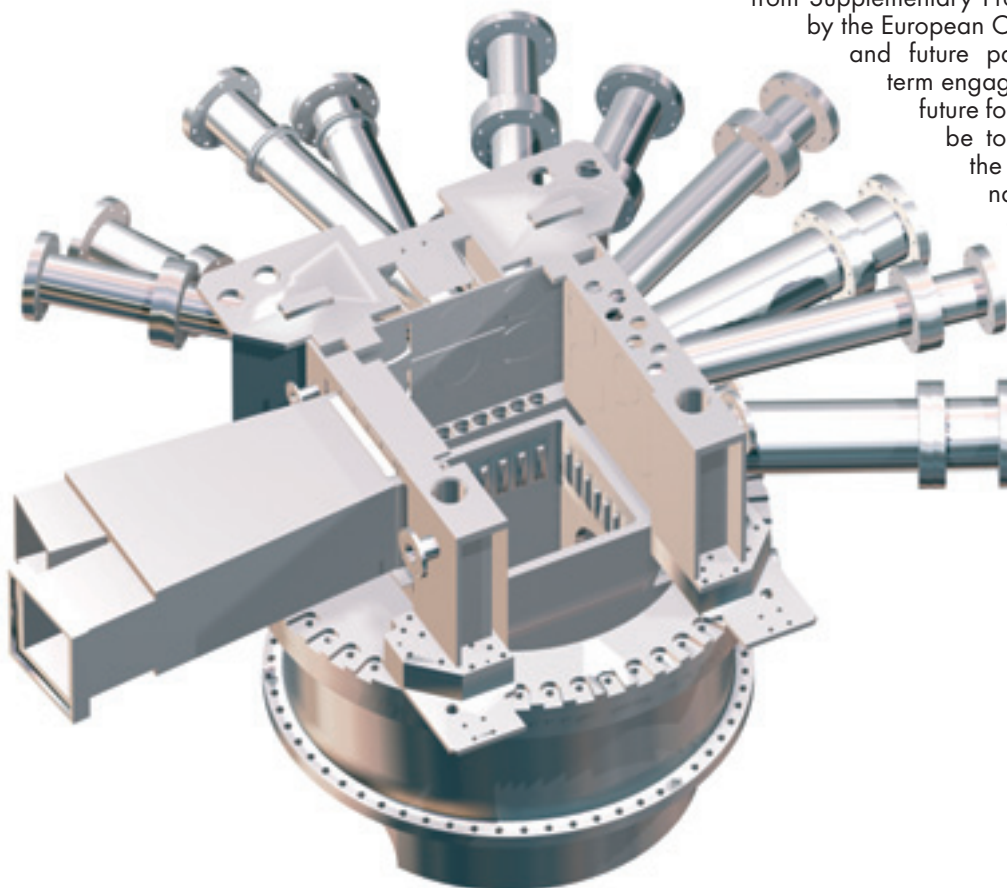

Roberto May

HFR: Reactor Management

HFR Operation and related services

In 2007 the regular cycle pattern consisted of a scheduled number of 287 operation days and two maintenance periods of 24.3 days each. During the spring maintenance period the planned modifications were successfully performed. During the summer maintenance period the extended reactor vessel In-Service Inspection of the bottom plug liner and the yearly containment leak test as well as several safety related modifications were successfully performed. In reality the HFR has been in operation for 275 days (Figure 1). The reduction of operating time can almost completely be attributed to problems related to a leaking bellow in the accident-pressure, equalisation lines which caused an extended shut-down. This corresponds to an actual availability of 94.52% with reference to the original scheduled operation plan. Nominal power has been 45 MW, with a total energy production of approximately 12,280 MWd, corresponding to a fuel consumption of about 15 kg ²³⁵U.

At the beginning of the reporting period, the HFR was out of operation for the loading of the cycle core for cycle 07.01. The 45 MW operation of cycle 07.04 was manually interrupted to replace a leaking bellow. To fulfil an optimal service to our customers and to optimize the fuel consumption, cycle 07.04 was stopped more than 16 days later than originally planned. The start of cycle 07.06 was interrupted at 25 MW power, for removal of an experiment. To fulfil an optimal service to our customers and not to hinder the planned works in the summer maintenance period, cycle 07.06 was ended as originally scheduled. HFR cycle 07.07 ended 45 minutes earlier than scheduled due to a lack of core reactivity caused by the optimized use of fuel elements. During the short cycle 07.06 the same fuel elements and control rods were used in cycle 07.07. Nearly all the cycles were started earlier than originally scheduled.

Table 1 - 2007 operational characteristics

			OPERATING TIME					SHUT-DOWN TIME				
Cycle Begin-End	HFR Cycle	Generated Energy	Planned	Low Power	Nominal Power	Other Use	Total	Planned	Unscheduled	Number of Interruptions		Stack Release (of Ar-41)
dd.mm		MWd	hrs	h.min	h.min	h.min	h.min	h.min	h.min	PD*	Scram	Bq x E+11
01.01 - 31.01	07.01	1256.47	664	04.25	669.15		673.40	70.20		3		3.8
01.02 - 04.03	07.02	1300.90	688	02.07	693.23		695.30	72.30				5.2
05.03 - 28.03	Maintenance period					03.32	03.32	547.24				
29.03 - 25.04	07.03	1253.37	664	03.47	666.57		670.44	25.06	00.10		2	5
26.04 - 27.05	07.04	1371.53	688	06.09	729.53		736.02	76.28	363.30	1	3	3.7
28.05 - 27.06	07.05	1152.10	664	01.55	613.52	00.47	616.34	79.30		1		2.9
28.06 - 29.07	07.06	661.87	688	02.38	351.48		354.26	48.45	04.49		2	1.7
30.07 - 21.08	Maintenance period and ISI							552.00				
22.08 - 19.09	07.07	1235.27	664	02.01	658.25		660.26	32.00	03.34		1	6.2
20.09 - 21.10	07.08	1292.87	688	01.51	689.18		691.09	76.51				5.3
22.10 - 21.11	07.09	1259.42	664	01.47	670.18		672.05	72.55				4.7
22.11 - 23.12	07.10	1251.93	688	03.01	666.32	20.40	690.13	67.20	10.27		1	4.9
24.12 - 31.12	08.01	244.99	192	02.44	129.46		132.30	59.30				
TOTAL :		12280.72	6952	32.25	6539.27	24.59	6596.51	1780.39	382.30	5	9	43.4
Percentage of total time in 2007 (8760 h) :				0.37	74.65	0.29	75.31	20.33	4.37			
Percentage of planned operating time (6952 h) :				0.47	94.07	0.36	94.89					

*PD: Power decrease

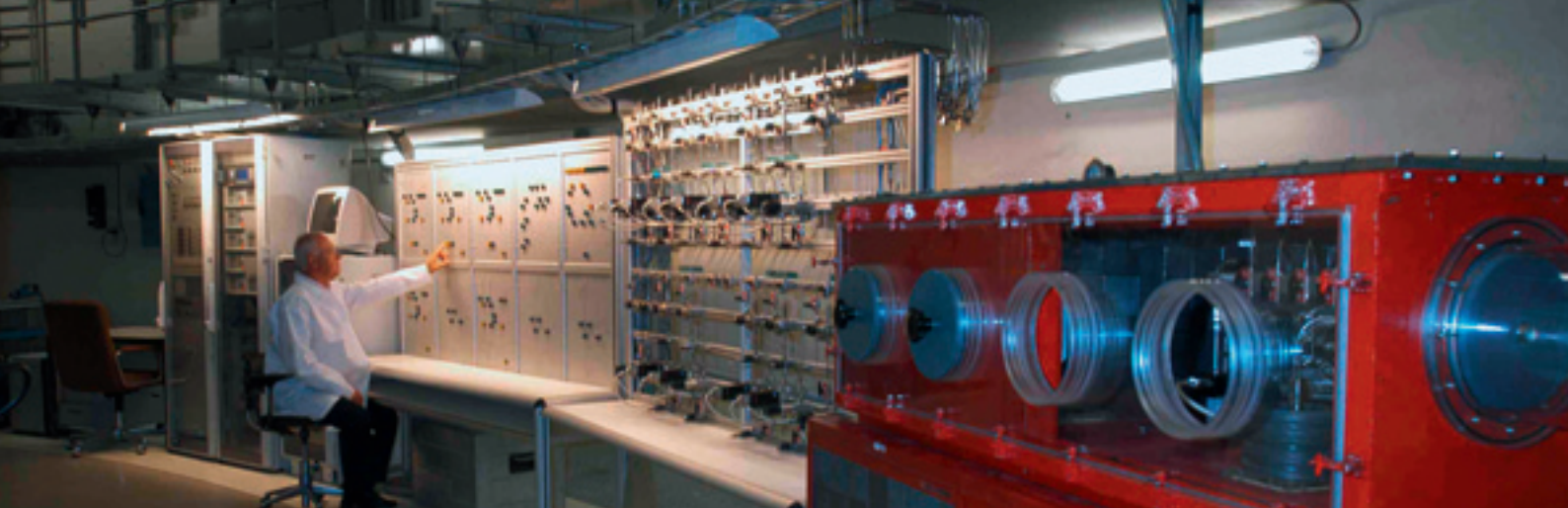

Figure 1 - HFR availability

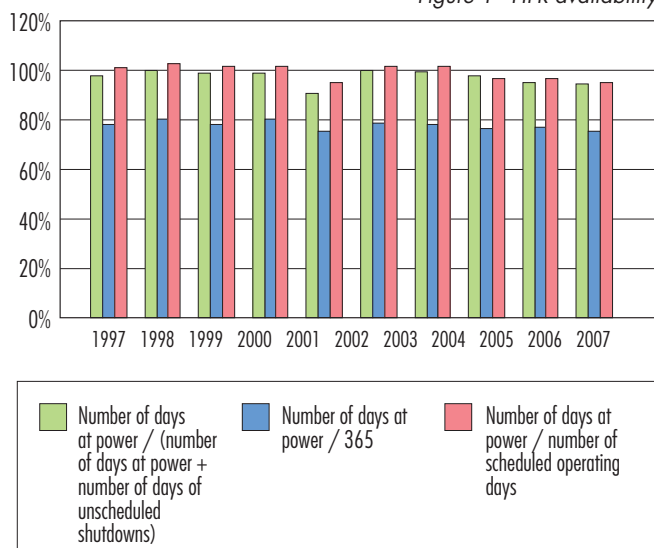
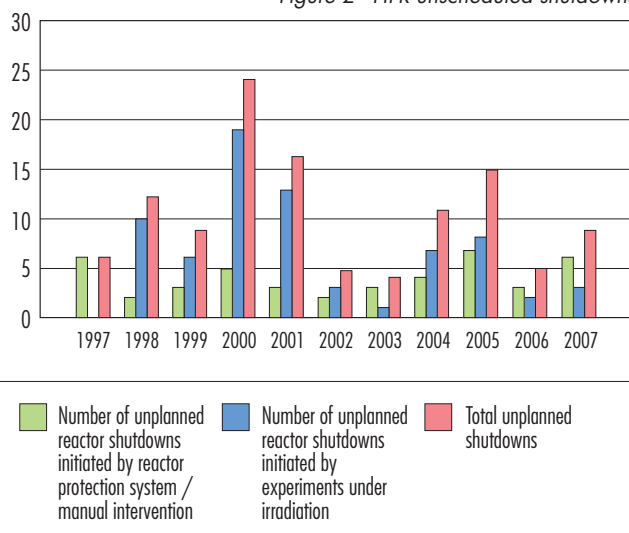

Figure 2 - HFR unscheduled shutdowns



Also two flux measurements at a reactor power of 500 kW in support of the HFR conversion programme have been carried out. At the end of the year, the annual reactor-training programme at 30 MW has been carried out. After the scheduled end of each cycle, the shut-downs included activities performed in the framework of the regular HFR's operators training.

The detailed operating characteristics for 2007 are given in Table 1. All details on power interruptions and power disturbances, which occurred in 2007, are given in Table 2. It shows that nine scrams occurred (see also Figure 2). Four of these scrams were due to human intervention, i.e. human error. Technical malfunctioning caused three others, while one was caused by loss of off-site power and the remaining one scram was due to intervention by safety systems of the experimental devices.

In 2007 many people visited the reactor. Apart from the usual visits of international colleagues and also relations in the medical world, the cycle based "HFR Open Days", attracted many visitors. A total of 1,482 people divided over 242 tours were guided through the facility.

Maintenance activities

In 2007 the maintenance activities consisted of the preventive, corrective and break down maintenance of all Systems, Structures and Components of the HFR as described in the annual and long term maintenance plans. These activities are executed with the objective to enable the safe and reliable operation of the HFR and to prevent inadvertent scrams caused by insufficient maintenance. Also the periodic leak testing as one of the licence requirements (0.5 bars overpressure for 48 hours duration) and the extended In-Service Inspection including the measurements

of the bottom plug liner were successfully performed. As part of the HFR Modification Plan several modifications were performed including:

- Replacement of the diesel-driven decay, heat removal pump by an electrical-driven pump;
- Measures to prevent the safety related consequences of postulated flooding of parts of the HFR buildings;
- Measures to mitigate the effects of postulated fires in buildings and compartments relevant to safety;
- Preparations to replace the cables and cabinets for the experimental devices;
- Improvements on the Uninterrupted Power Supply (UPS) and the Emergency Power Supply;
- Improvements on the HFR interlock (physical separation and redundancy).

All modifications were implemented after revision of the plant description and operating instructions and following successful commissioning and testing.

Figure 3 - Radioactivity discharged (licence limit 100 Re/year)

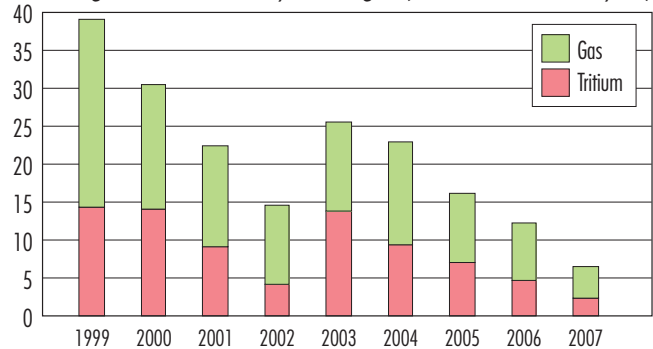

DATE	CYCLE	TIME OF ACTION	RESTART OR POWER IN-CREASE	NOMINAL/ORIGINAL POWER	ELAPSED TIME TO		DISTURBANCE CODE				REACTOR SYSTEM OR EXPERIMENT CODE	COMMENTS
					RESTART OR POWER INCREASE	NOMINAL/ORIGINAL POWER	1	MW	2	3		
		hour	hour	hour	h.min	h.min						
15 Jan	07.01	14:34		15:07		00.33	MP	20	P	R	Incomodo	Due to unloading problems with the production facility INCOMODO 347-01 three manual power decreases were required.
15 Jan	07.01	15:25		15:48		00.23	MP	20	P	R	Incomodo	Due to unloading problems with the production facility INCOMODO 347-01 three manual power decreases were required.
15 Jan	07.01	16:20		17:00		00.40	MP	20	P	R	Incomodo	Due to unloading problems with the production facility INCOMODO 347-01 three manual power decreases were required.
16 Apr	07.03	11:48	11:52	12:19	00.04	00.31	AS	0	R	I	Primary system	During the spring maintenance period maintenance has been carried out on primary pump 3. Therefore the nominal flow of primary system is slightly lower than during cycle 07.02. This caused a reactor scram on <90% of the primary flow.
16 Apr	07.03	15:20	15:26	15:52	00.06	00.32	AS	0	E	M	Mykonos 267-06 and 09	A pressure decrease in the coolant systems of Mykonos 06 and 09 due to the failure of one of the U-BWKWS pumps caused a reactor scram.
07 May	07.04	08:58					MS	0	R	M	Primary system	Due to a leak in the bellow of the APES line on the second floor South the reactor was manually shut down.
22 May	07.04		12:17	15:07	363.19	366.09						
23 May	07.04	14:10	14:21	14:23	00.11	00.13	AP	20	A	H	Pool system	Due to cleaning of the flow glass of the pool monitor system air was introduced in the pool system after which an automatic power decrease occurred.
29 May	07.04	18:08	18:15	18:22	00.07	00.14	AS	0	E	H	Mykonos 267-09	A pressure rise in the coolant systems of Mykonos 09 caused a reactor scram due to handling of an other facility.
05 Jun	07.06	09:20	09:21	09:23	00.01	00.03	MP	35	R	E	Power demand	Manual intervention of the reactor power by operating "all rods down" due to incorrect functioning of the power demand.
05 Jun	07.06	14:57	15:01	15:22	00.04	00.25	AS	0	R	E	Power demand	Due to incorrect functioning of the power demand the reactor was shutdown by high power protection safety channels.
14 Jul	07.06	10:15	15:00	15:54	04.45	05.39	MS	0	E	H	Sumo 320	Due to a human error, SUMO -10 was loaded instead of SUMO 11/12.
25 Jul	07.06	13:24	13:28	13:42	00.04	00.18	AS	0	E	H	Mykonos 267-06	A defect thermocouple (varying indications) of experiment 267-06 necessitated measurements in COBO. The wrong execution of measurements in COBO caused a automatic reactor shut-down.
19 Sep	07.07						MS	0	R	H	Keff <1	After withdrawal of the fuel loaded experiment Tycomo (354-01), the core reactivity was insufficient. The reactor operation was manually shut-down 45 minutes earlier than planned end-of-cycle.
12 Dec	07.10	13:55	14:00	14:16	00.05	00.21	AS	0	A	E	Mains power supply	Loss of off-site main power supply causing a reactor scram.
1. LEADING TO			2. RELATED TO			3. CAUSE						
- automatic shut-down		AS	- reactor		R	- scheduled		S			- mechanical	M
- manual shut-down		MS	- experiment		E	- requirements		R			- electrical	E
- automatic power decrease		AP	- auxiliary system		A	- instrumentation		I			- human	H
- manual power decrease		MP	- production facility		P							

Table 2 - 2007 full power interruptions of HFR

Renewal of Nuclear Infrastructure

Management Chain

Last year, exploitation of the High Flux Reactor (HFR) and the Hot Cell Laboratories (HCL) has grown. It is the ambition of the HFR operator NRG jointly with JRC-IE to always improve these facilities and to exploit them more safely. For this reason, the nuclear infrastructure is considered as a production organisation, as a component of a chain.

This production organization focuses on two important activities: high quality nuclear research and the production of medical isotopes. These activities start with a market, customers and customer needs and they finish with the supply of the research result or the medical isotope. In other words, a chain of activities with the goal to satisfy customer expectations. For NRG as a production organisation in the chain, this means that we continuously aim at an excellent management, on all aspects, of the High and Low Flux Reactors and Hot Cell Laboratories.

Figure 4 - Chain concept

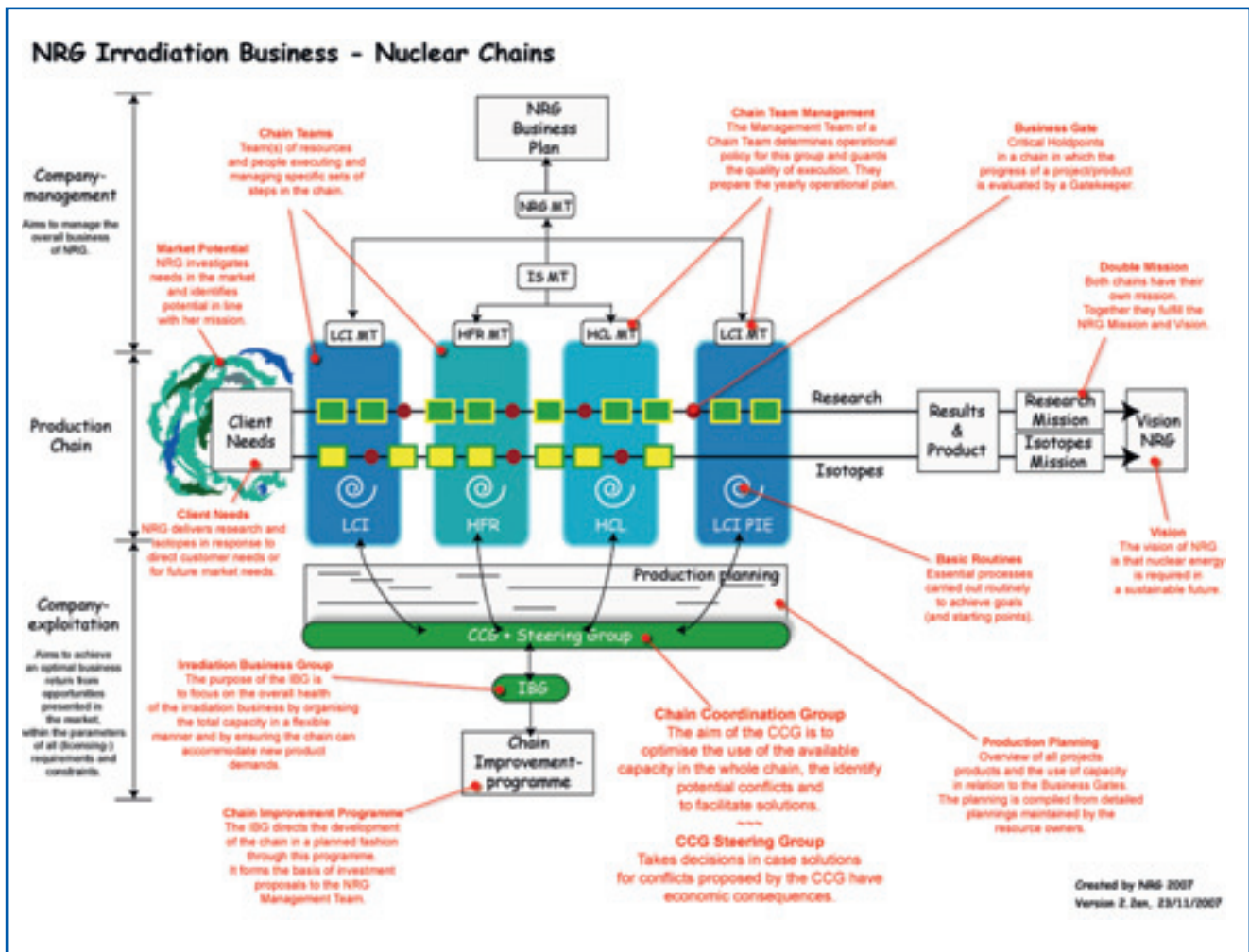

Jaap Goedkoop Laboratory¹



Figure 5 - Jaap Goedkoop Laboratory

On 1st November 2007, NRG's new research facility the Jaap Goedkoop Laboratory was inaugurated. The laboratory houses various facilities for present and future research on the development of innovative fuels for nuclear plants, fusion research, immobilization of radioactive waste and the

⁽¹⁾ Professor Jaap Goedkoop was a pioneer in the field of nuclear energy and director of Reactor Centrum Nederland, precursor of NRG.

development and production of medical isotopes, thus complementing the HFR irradiation capabilities and enhancing the possibilities of research in the nuclear field at the Petten Site. The facility offers a wide range of analytical tools including mass spectrometry, gamma spectrometry, X-ray diffraction and transmission electron microscopy.

The design of the Jaap Goedkoop Laboratory makes it possible to accommodate adaptations of the infrastructure and experimental set-up, allowing optimal flexibility in the future to meet new demands of the users.

Figure 6 - Fabrication of Lutetium in the Jaap Goedkoop Laboratory



Fuel Cycle



Figure 7 - Transport of MTR2 container



Figure 8 - Arrival at the HABOG facility of COVRA

Front end

Since May 2006, the HFR is running on Low Enriched Uranium (LEU) fuel. During 2007, new LEU fuel elements and control rods were inspected at the manufacturer's site and delivered on schedule.

Back end

In 2007, the transport of spent fuel in MTR2 containers to COVRA continued. In total 132 High Enriched Uranium (HEU) elements, over four shipments, took place. At the end of 2007, 148 HEU elements are still in the HFR area which are planned to be shipped in 2008 and 2009 over five shipments. The COVRA has already received the licence to accept spent fuel in 2008 and 2009. Including 2007, 18 positions out of 48 positions are filled in the HABOG at COVRA.

The Gesellschaft für Nuklear-Service (GNS) carried out the compulsory 3 years inspection of one of the MTR2 containers. After a small repair, the licence of the container was extended. Finally, concerning the MTR2 containers, some ordered spare parts, such as seals, were delivered.

In December 2007, the IE signed a contract with NRG concerning the removal and disposal of "historic" High Active Waste (HAW) which was in the HFR pool. This waste originates from experiments and from the HEU fuel cycle. The total mass of the HAW is approximately 2,538 kg. It is expected that the waste shipment to COVRA will be completed by 2014.



Figure 9 - Unloading the MTR2 container at the HABOG facility of COVRA



Figure 10 - MTR2 container at COVRA on its way to the docking station underneath the hot cell of HABOG



Visits and Visitors

January	12	Mr. H. Borghouts (Commissaris van de Koningin) and members of Provinciale en Gedeputeerde Staten	1
	24	Exchange Programme between IE-ECN-NRG and representatives of the Dutch Ministry of Housing, Spatial Planning and the Environment Representatives of Provincial Government of North Holland	
	31	Mr. R. Rintamaa, Vice President, Business Solutions VTT, Finland	
February	05	Representatives of Regional Government in North Holland	
	15	Prof.Dr. T. Fanghänel, Director of the Institute for Transuranium Elements, Karlsruhe	
March	01	Dr. Hahn, technical and scientific director of GRS (Gesellschaft für Anlagen- und Reaktorsicherheit) with his assistant Dr. Maqua, Dr. Teschendorff (GRS Reactor Safety Research) and JRC Director General Mr. R. Schenkel	
	07	Representatives of the Dutch Ministry of Education , Culture and Science	
	21	Mrs. J.G. van der Linde, director of the Clingendael International Energy Programme (CIEP), Mrs. L.G. van Geuns (deputy director CIEP) and Mr. J. de Jong, (senior fellow CIEP)	
April	18+19	Visit to the HFR by Students of the 7th year (with option physics) of the European School	
	19	Mr. K. Maruszewski, Director of JRC Institutional and Scientific Relations, Brussels	
May	01	Students (laboratory) of the Amstel Academy, Amsterdam	
	23	Visit of delegates of the Chinese Society of Power Engineering	
June	07	European Young Generation Forum	
	08	International meeting nuclear engineering and radiological sciences	
	27	Students of the Jan Arentsz Scholengemeenschap, Alkmaar	
September	04	Representatives of the Dutch Ministry of Housing, Spatial Planning and the Environment	
	09	Representatives of the Dutch Ministry of Economic Affairs	
	11	European Council Atomic Question Group	2
November	20	Representatives of TÜBİTAK; The Scientific and Technological Research Council of Turkey	3
	22-23	JRC Board of Governors Meeting	4
December	05	12 th NET Steering Committee Meeting	

Workshops and seminars

September	18-20	Workshop on the safety of CANDU Reactors
October	11-13	JRC Enlargement & Integration on BNCT: Clinical Trials in BNCT
November	25-26	JRC Enlargement & Integration workshop: "Boron Analysis and Boron Imaging for BNCT", held at Bucharest, with presentations by European experts covering the many aspects of Boron Measurements
December	03-04	The 4 th NET-PECO workshop on Residual stress: measurement, prediction and relevance for integrity



HFR: The Programmes

EUROPEAN NETWORK AMES AND SAFELIFE

The internal JRC project SAFELIFE provides an integrated approach to research and development on safety issues for plant life management of ageing nuclear power installations. It focuses on establishing European best-practices for deterministic and risk-informed structural integrity assessment of key components considering all nuclear power plant (NPP) designs (both western and Russian). It exploits IE's competence in testing and characterisation of materials degradation (radiation embrittlement modelling development, thermal fatigue, stress corrosion cracking), structural mechanics, ageing monitoring methods development and qualification, neutron methods and advanced modelling techniques for residual stress analysis, as well as developing appropriate new areas of expertise.

The activities in 2007 focused on the following key primary circuit components: reactor pressure vessel, primary piping, core internals and their welds. In addition to these component-specific activities, further activities cover method development on more generic topics supporting decision making in life management. SAFELIFE also exploits its available capabilities and competences to support safety studies on materials for advanced reactor designs and for analysis of components under extreme loading conditions.

SAFELIFE continues to support European networks AMES, NESAC and NET and associated training activities within the frame of the European Research Area, as well as the new Network of Excellence NULIFE and the integrated project PERFECT.

The strategic multi-annual goals are as follows:

- Provide a scientific/technical basis for harmonisation of European codes and standards on key primary components of light water reactors through developing and disseminating best practices
- Support long-term EU policy needs on PLIM and advanced reactor concept through enhancing JRC R&D competence and capabilities in nuclear safety technology
- Integration of R&D efforts in line with ERA principles by linking R&D to utilities, manufacturers, R&D organisations and regulators through continuing exploitation of networks and collaborating with EC and international organisations
- Implementation of an effective plan for training, mobility, dissemination and knowledge management and development of competitive activities complementary to SAFELIFE objectives.

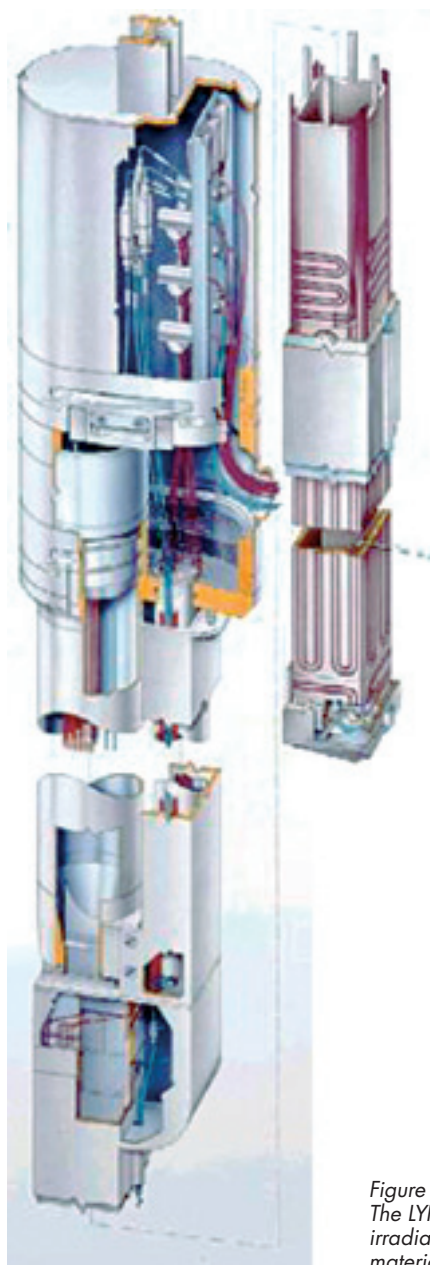

Figure 11 -
The LYRA capsule for
irradiation of structural
material samples



Figure 13 - Periodic rotation of the LYRA-10 sample holder to ensure uniform fluence distribution

Radiation Embrittlement

A series of tasks directly address irradiation embrittlement to improve understanding of reactor pressure vessel integrity issues, with emphasis on material characterisation, irradiation embrittlement understanding, fracture toughness and application of probabilistic approaches for structural reliability analysis. The work is mainly co-ordinated within the frame of the AMES and NESC European Networks. The tasks include: irradiation of different RPV steels in the LYRA rig at the HFR, studies on non-destructive measurements of cladding radiation embrittlement (irradiated in the HFR), based on non-destructive methods, such as the STEAM method and Barkhausen Magnetic method, for the characterisation of materials, as well as for IAEA International Benchmarking projects (model alloys, model steels and realistic welds projects). Other studies include intergranular fracture, characterisation of materials for future vessels (Cr-Mo-V based alloys), support to large international projects such as PERFECT and COVERS, etc.

The LYRA irradiation capsule (Figure 11) has now been operated successfully for more than 10 years (see Table 3). The latest campaign "LYRA-10" (experiment 304-10) was loaded into the PSF in May 2007. It addresses a series of special reactor pressure vessel materials namely "model steels", "realistic welds" and high nickel welds. The "model steels" consists of 12 batches of steels with the basic typical composition of WWER-1000 and PWR reactor pressure vessel materials and with parametric variation in the contents of alloying elements and impurities.

Table 3 - LYRA rig: 10 years of successful operation

LYRA I	REFEREE - Nuclear Electric	190°C, $11.5 \times 10^{22} \text{ m}^{-2}$	Terminated
LYRA II	RESQUE / SCK	255°C, $8.17 \times 10^{22} \text{ m}^{-2}$	Terminated
LYRA III	MODEL ALLOYS/JRC	270°C, $6.11 \times 10^{22} \text{ m}^{-2}$	Terminated
LYRA IV	PISA I/British Energy	200°C, $5 \times 10^{22} \text{ m}^{-2}$	Terminated
LYRA V	FRAME/VTT	280°C, $20 \times 10^{22} \text{ m}^{-2}$	Terminated
LYRA VI	PISA II/British Energy	290°C, $5 \times 10^{22} \text{ m}^{-2}$	Terminated
LYRA VII	PISA III/British Energy	290°C, $18 \times 10^{22} \text{ m}^{-2}$	Terminated
LYRA VIII	NRG irradiation	HTR materials	Terminated
LYRA IX	VVER-440/FZR	265°C	Unloaded end 2006
LYRA X	Model Steels and Welds/JRC	290°C	Started May 2007; end 2009

These have been developed by IE to better understand the influence of Ni, Si, Cr and Mn as alloying elements as well as impurities such as C and V on radiation embrittlement. The "realistic welds" were specially manufactured on the bases of the typical WWER-1000 weld composition with variation of certain elements such as Ni, Si, Cr and Mn. The scope of the experiment is to irradiate to a sufficient fast neutron fluence to determine the influence of these elements on radiation-induced damage (Figure 12). The irradiation temperature is 290°C for a target fast fluence of approx. $5 \times 10^{23} \text{ n/m}^2$ ($E > 1 \text{ MeV}$). In late 2007 the sample holder was rotated 180° to make the accumulated fluence as uniform as possible (Figure 13).

The analysis of the samples from the previous LYRA campaign to study materials taken from WWER reactors during decommissioning in Germany is in progress with partnership with Forschung Zentrum Rossendorf. The results, together with results from recently completed EC framework programme projects such as FRAME and PISA, will support the validation of advanced methods for structural integrity assessment of reactor pressure vessels, in particular the Master Curve approach.

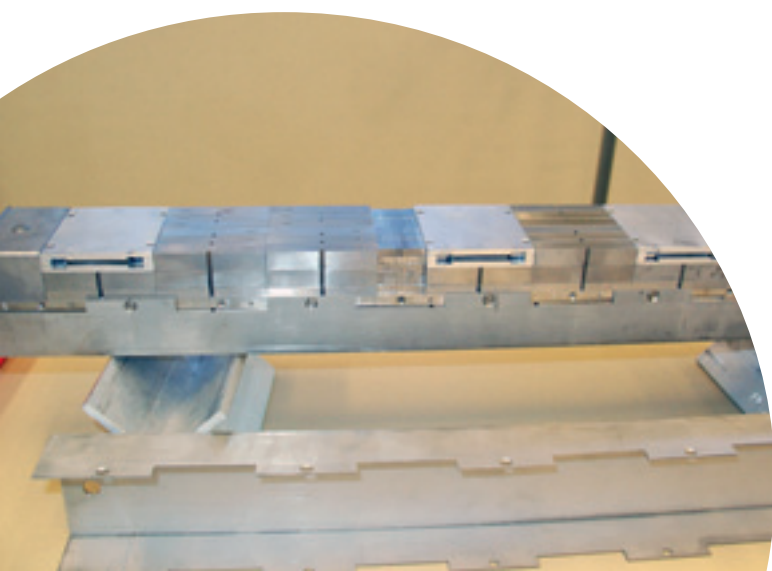
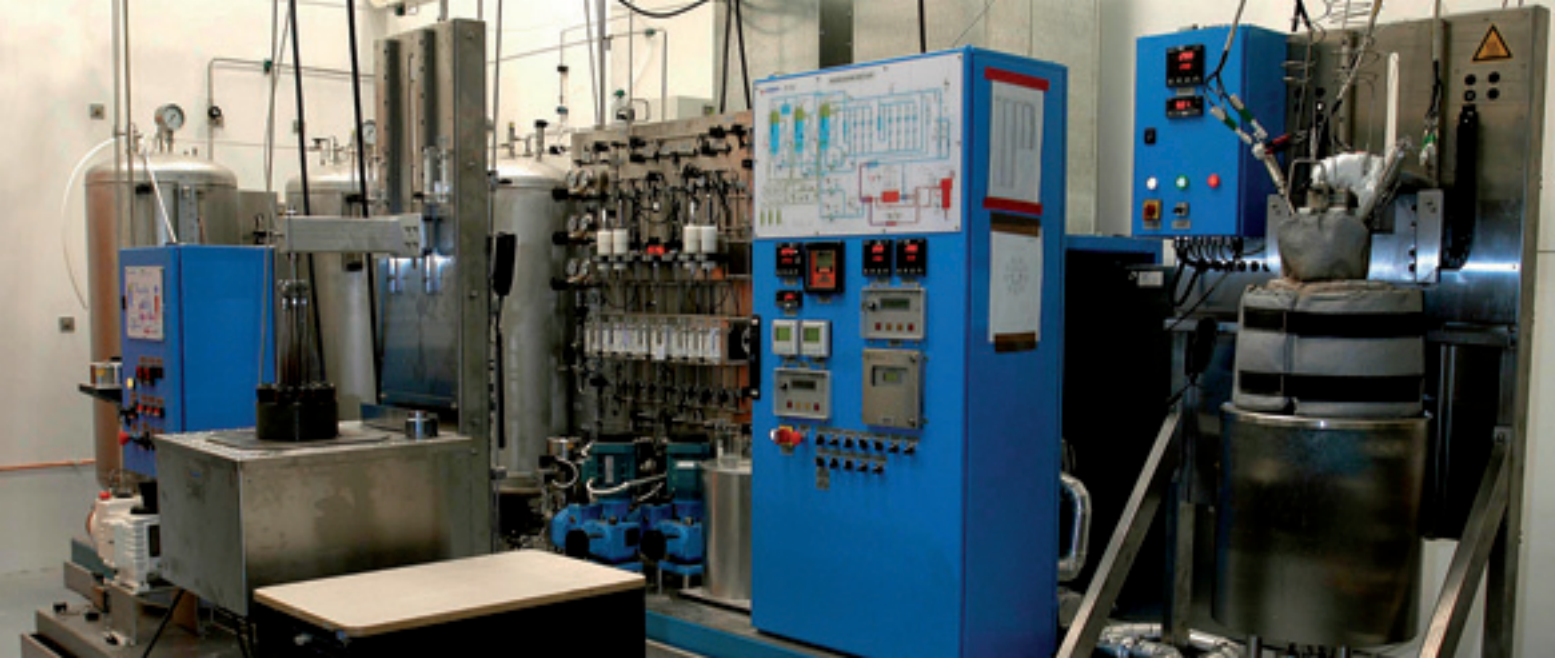

Figure 12 - Preparation of samples for the LYRA-10 experiment loaded into the HFR in May 2007: 55 Charpy-size samples (10x10x55 mm), 72 half-Charpy V-notch (10x5x55), 309 mini-Charpy (3x4x27.5 mm), 14 bars (45.4x10.8x2 mm), 5 strips (37x0.5x190 mm), 89 slices, 48 B6 tensile and 72 B5 tensile samples have been loaded



Irradiation Assisted Stress Corrosion Cracking

Activities to support the possibility of introducing an IASCC (Irradiation Assisted Stress-Corrosion Cracking) loop to the HFR are progressing, with the continued expansion of the out-of-pile SCC loops in the AMALIA lab (Figure 14). These devices aim at providing reliable data relevant to BWR, PWR and VVER reactor systems, as well as future systems using super critical water.



Figure 14 - AMALIA Autoclave for Stress Corrosion Cracking (SCC)

SAFETY OF INNOVATIVE REACTOR DESIGNS (SAFETY-INNO)

The institutional action "Safety of Innovative Reactor Designs" (SAFETY-INNO) carries out R&D related to future nuclear power plants for the medium and the long term in synergy with several FP6 and FP7 indirect actions.

In 2007, the action pursued essentially four multi-annual activities:

- Safety/feasibility studies on innovative reactor concepts, non-electricity production applications of nuclear power and proposals for further improvements.
- Qualification of fuel for High Temperature Reactors and closed fuel cycles (transmutation fuel) through irradiation tests.
- Qualification of structural and functional materials for next generation reactors in out-of-pile tests.
- International cooperation, including operation of the High Temperature Reactor Technology Network (HTR-TN) and participation in Generation IV International Forum bodies and IAEA/INPRO projects.

Tasks focused on feasibility and safety optimization of reactors, fuel and fuel cycles, and materials targeting improved sustainability and minimum waste. Good, but not necessarily final, examples for such reactors are the six Generation IV International Forum (GIF) concepts VHTR (Very High Temperature Reactor), SCWR (Super-Critical Water Reactor), SFR (Sodium-cooled Fast Reactor), LFR (Lead-cooled Fast Reactor), GFR (Gas-cooled Fast Reactor) and MSR (Molten Salt-cooled Reactor). With the exception of the MSR which has a particularly long-term perspective still providing relatively little opportunity for international cooperation, all GIF concepts were analyzed with the objective to identify and possibly eliminate potential showstoppers in terms of feasibility and safety. The concepts for which the existing technology basis and international cooperation are currently best developed are the SFR (to maximize nuclear fuel sustainability from U-238 stockpiles) and the VHTR (for medium-size electricity and for process heat applications).

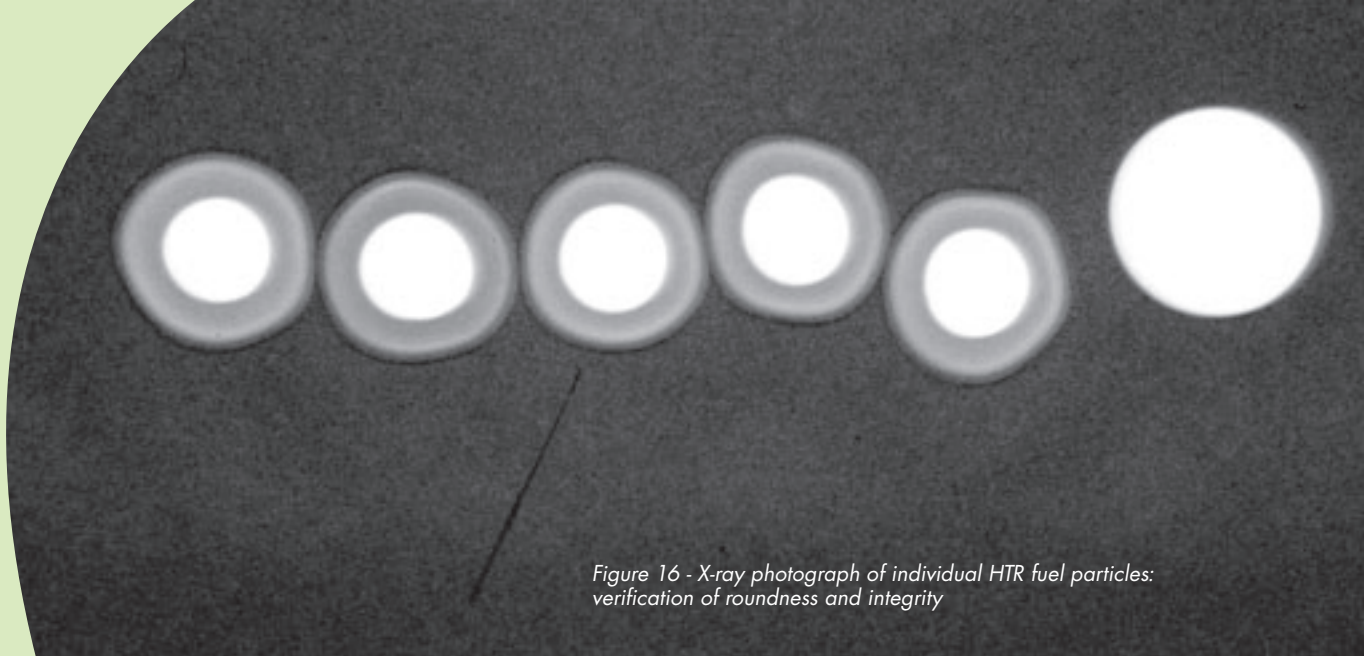

Figure 16 - X-ray photograph of individual HTR fuel particles: verification of roundness and integrity

HIGH TEMPERATURE REACTOR TECHNOLOGY NETWORK – HTR-TN

Background

In response to growing interest in HTRs worldwide and on the initiative of JRC, HTR-TN was established in April 2000 to recover, maintain and develop HTR technology from Europe and elsewhere. The ultimate goal is the development of advanced HTR technologies thus supporting industry in the design of power plants which comply with stringent requirements in terms of sustainability and waste, economic competitiveness, safety and public acceptance. Since its creation, HTR-TN has performed very successfully and contributed to an efficient EU-wide exchange, including the organization of specialist meetings, seminars and conferences. JRC-IE is the operator of HTR-TN, contributes to the coordination of related projects and provides technical input through both institutional and indirect actions. HTR-TN is driven currently by 21 partners and several observers from industry, research and academia.

Achievements 2007

The network partners efficiently coordinated and supervised the execution of several HTR-related R&D projects within the EU's FP6 and FP7 and submitted several new R&D project proposals to DG RTD, including non-electricity production applications. These project proposals were in line with the HTR-TN roadmap which was further updated, refined and detailed. In particular, HTR-TN has started to develop contacts with process heat end-users (e.g. from the chemical industry) to better integrate their requirements into reactor system design. This strategy will be integrated in 2008 into the "Strategic Research Agenda" document for identifying R&D issues for next generation power system to be compiled by the newly created Sustainable Nuclear Energy Technology Platform (SNE-TP), which is an advisory body to DG RTD and will shape the future nuclear R&D landscape. Much of JRC-IE's technical achievements within HTR-TN were proposed as Euratom input to related Generation IV International Forum (GIF) projects. JRC representing Euratom in GIF has provided members to high-level GIF bodies and GIF project management boards, thus significantly contributing to the up and running of this international cooperation.

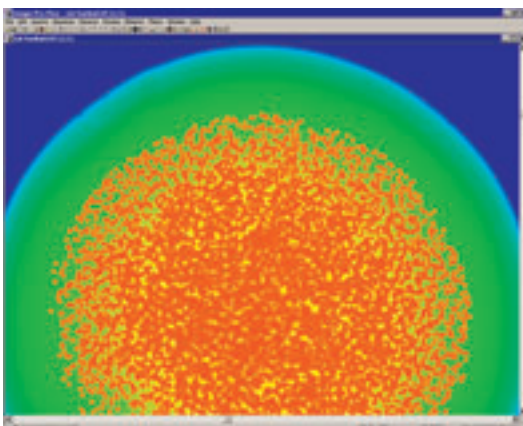

Figure 15 - X-ray photograph (colour enhanced) of a High Temperature Reactor spherical fuel element (diameter 6 cm): verification of homogeneous fuel particle distribution within the graphite matrix.

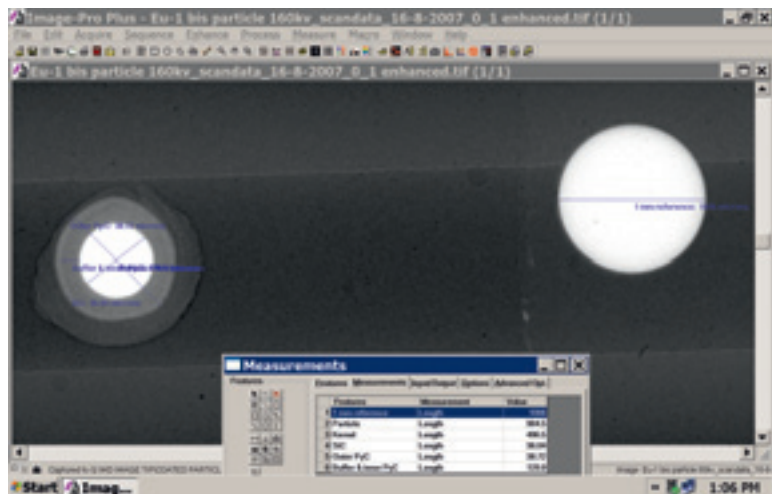

Figure 17 - X-ray photograph of irradiated individual HTR fuel particle: metrology of coating thickness



Figure 18 - 12th NET Steering Committee Meeting, IE Petten, December 2007

NETWORK ON NEUTRON TECHNIQUES STANDARDISATION FOR STRUCTURAL INTEGRITY (NET)

NET, the European Network on Neutron Techniques Standardization for Structural Integrity, supports progress towards improved performance and safety of European energy production systems. The state of the art in assessing internal stresses, microstructure and defects in welded nuclear components, as well as their evolution due to operational loads and irradiation exposure, needs to be improved, before relevant structural integrity assessment procedures can safely become less conservative.

In 2007 the partners of NET established two new Task Groups (TG) in addition to the ongoing TGs dealing with the assessment of welding stresses and the impact of thermal ageing on certain steels. The new TGs will embark on residual stress assessments in weld geometries that are not tackled in the existing work programme. It is envisaged in the medium term future that the work done within NET becomes an important part of a European Compendium of residual stress distributions in specific example cases of welds.

About 35 organizations are actively participating in the work of NET, including eight organizations from the new member states, three organizations from candidate countries, one from Russia and one from South Korea. Recently, the Australian Nuclear Science and Technology Organisation (ANSTO) has proposed to become a contributor to NET. During 2007 the NET Steering Committee met twice and significant progress has been made in carrying out the work within its TGs (Figure 18). In December 2007 an enlargement and integration workshop has been organized focusing on residual stresses and their assessment. About 22 scientists from 10 European countries, including Russia and Turkey, attended this workshop.

NET work programme development and execution

• TG1 - *Single Bead on Plate Weld*

The purpose of this Task Group was to perform, by experimental and numerical methods, a thorough assessment of the three-dimensional residual stress field around a single weld bead laid down on a small stainless steel plate. The work had largely been completed before the end of 2006. In 2007 additional analyses of the experimental data have been performed. A slightly different approach to the Bayesian averaging of such data has been developed by HMI based on the experience with the available data sets. A number of phase 2 numerical analyses contributed in 2007.

The preparation of the dedicated TG1 edition of the International Journal of Pressure Vessels and Piping is well underway. In 2007 a preliminary and a formal review of the 15 papers submitted were done. The aim is to finalize all papers and to submit them for publication in the course of 2008.

• TG2 - *Assessment of post-weld stress relief heat treatments*

Task Group 2 has progressed slowly in 2007. The University of Patras has performed numerical residual stress analyses on the 18 bead letterbox repair weld specimens. They have applied different methods of bead lumping in order to obtain manageable CPU time for 3D calculations. Agreement with experimental results obtained before at JRC was remarkable. INR-Pitesti has performed 2D numerical analyses of the auxiliary specimen. They compared a restrained to an unrestrained situation. Partial agreement with neutron diffraction results obtained at FRM-II has been achieved. It is possible that 2D modelling is not sufficient in this case. The Open University has applied the contour method for residual stress analysis in the 18-bead specimens. Good agreement has been achieved with the neutron diffraction data of JRC. The JRC has embarked on a very comprehensive series of stress measurements in the auxiliary specimens using the new diffractometer at beam tube HB5. A selection of results obtained for the welding longitudinal direction is shown in Figure 19.

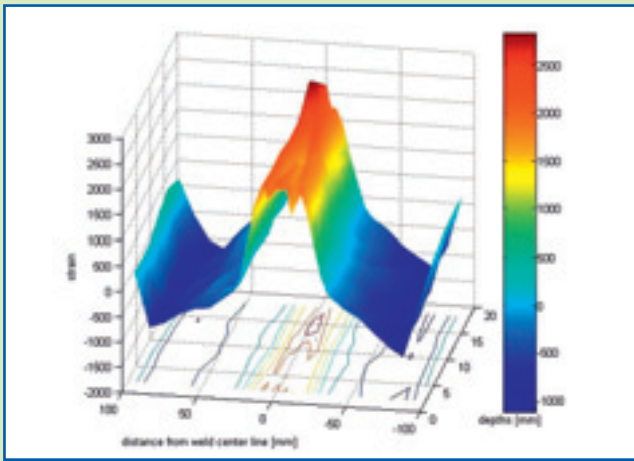

Figure 19 - NET TG2 Auxiliary specimen: distribution of welding longitudinal strains over a plane cutting through the weld at mid-length of the specimen

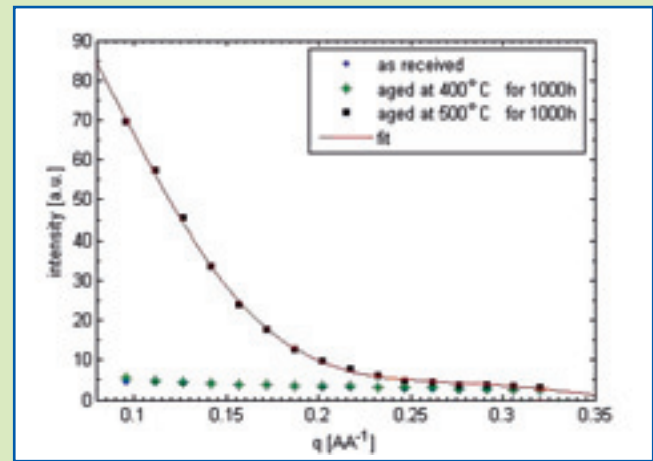

Figure 20 - NET TG3: HFR-SANS measurement on duplex stainless steel specimens aged at 400°C and 500°C for 1000h

• **TG3 - Assessment of effects of thermal ageing on cast duplex stainless steels**

Due to the unavailability of facilities and several contributors from NET, slightly less work could be performed in TG3 in 2007. The major new technical contribution to TG3 has been made by JRC. Figure 20 shows the results of HFR-SANS measurements on duplex stainless steel of type UR45N. There is no difference between the as received sample and the one aged at 400°C for 1000 hours. However, when the sample is aged at 500°C for 1000 hours the signal increases considerably due to decomposition and precipitation of Cr-rich and Cr-poor α -phases. Since the sizes are very small in the early ageing times, this decomposition cannot be detected by other methods, such as for example TEM. The fit for analysis of this data is performed by using the form factor for spherical particles, which has been convoluted with the resolution function. From this assessment an average particle diameter of the precipitates of 37 Å has been obtained

• **TG4 - Residual stresses in a three-pass slot weld in an austenitic stainless steel plate**

The new TG4 has been established by decision of the NET Steering Committee Meeting in June 2007. TG4 builds on the experiences obtained in TG1 and TG2 Auxiliary. From TG1 the material choice – stainless steel – and the organization of the work are derived, the specimen geometry is foreseen to be similar to TG2 Auxiliary, i.e. a slot weld. Preliminary work on TG4 has started with the meeting of a dedicated Steering Group in October 2007. By the end of the year the planning for the specimen manufacture was well underway. It is foreseen to make an effort to complete the work within TG4 in a period of about three years.

• **TG5 - Residual stresses in ferritic steel welds**

This new NET TG builds on an ongoing national UK research programme on welds in ferritic steel specimens. SERCO ASSURANCE proposed to include part of this work into the NET programme in 2007 and several partners, both from the experimental and from the numerical side of stress analysis, declared their interest in contributing to this work. It was agreed to first embark on residual stress analyses in an autogenous beam edge weld in a ferritic steel. Toward the end of the year the corresponding experimental and numerical protocols have been prepared, specimens have been manufactured and the first test measurements have been performed by the University of Manchester at the research reactor Munich, FRM-II.

Other NET activities

In 2005, a contract for third party work had been obtained for residual stress investigations in welded nuclear components at the HFR neutron beam facilities. The award of this contract was based on similar work performed in 2004 for the same contractor. Two different components have been delivered for these investigations. One of them to be tested before and after stress relieving heat treatment. Investigations continued in 2007 and were finally completed in early January 2008. An IAEA driven collaborative research project with participation of the NET Team on research reactors and their residual stress measurement capabilities had been established in 2006 with duration of three years. During the second project meeting in autumn 2007, JRC assumed responsibility for the organization of the round robin exercises to establish the performance of the participating facilities. In the context of this collaboration, JRC also receives technical advice for the development of its own facilities at the HFR from other participants. JRC participated in an international workshop on residual stress determination by non-destructive measurement methods (WONERS 2007). In the course of this workshop three one-hour presentations were given on stress measurement by neutron and synchrotron diffraction and on standardization of these measurement methods. During this workshop contact was established with a representative from the NRC (USA), potentially forming the basis for future collaborations in the field.



HFR as a Tool for Research

NEUTRON BEAM RESEARCH

In 2007 the HFR Unit has continued its efforts to upgrade and revitalize the neutron beam facilities at the High Flux Reactor. Modifications and upgrades have been made at the residual stress measurement facilities at beam tubes HB4 and HB5, and the Small Angle Neutron Scattering facility at beam tube HB3b. NRG has been using the diffractometer at beam tube HB3a for powder investigations on behalf of Leiden University throughout the year.

New facility at HFR/HB5: VISA – the Versatile Instrument for Stress Analysis

Work on the installation of the new residual stress diffractometer at beam tube HB5 was completed in 2007. A substantial amount of time went into the development and installation of the instrument control software. After the software had been brought to an operational state, the instrument was aligned with respect to the beam, a process that was substantially facilitated by the new “Tanzboden” floor and the air cushions. Alignment of the instrument, installation of the neutron beam defining masks and beam optimization were the last steps before the new instrument finally went into operation in November 2007.

Figure 21 - HFR/HB5: NET TG2 auxiliary specimen installed on new diffractometer for residual stress analysis (VISA)

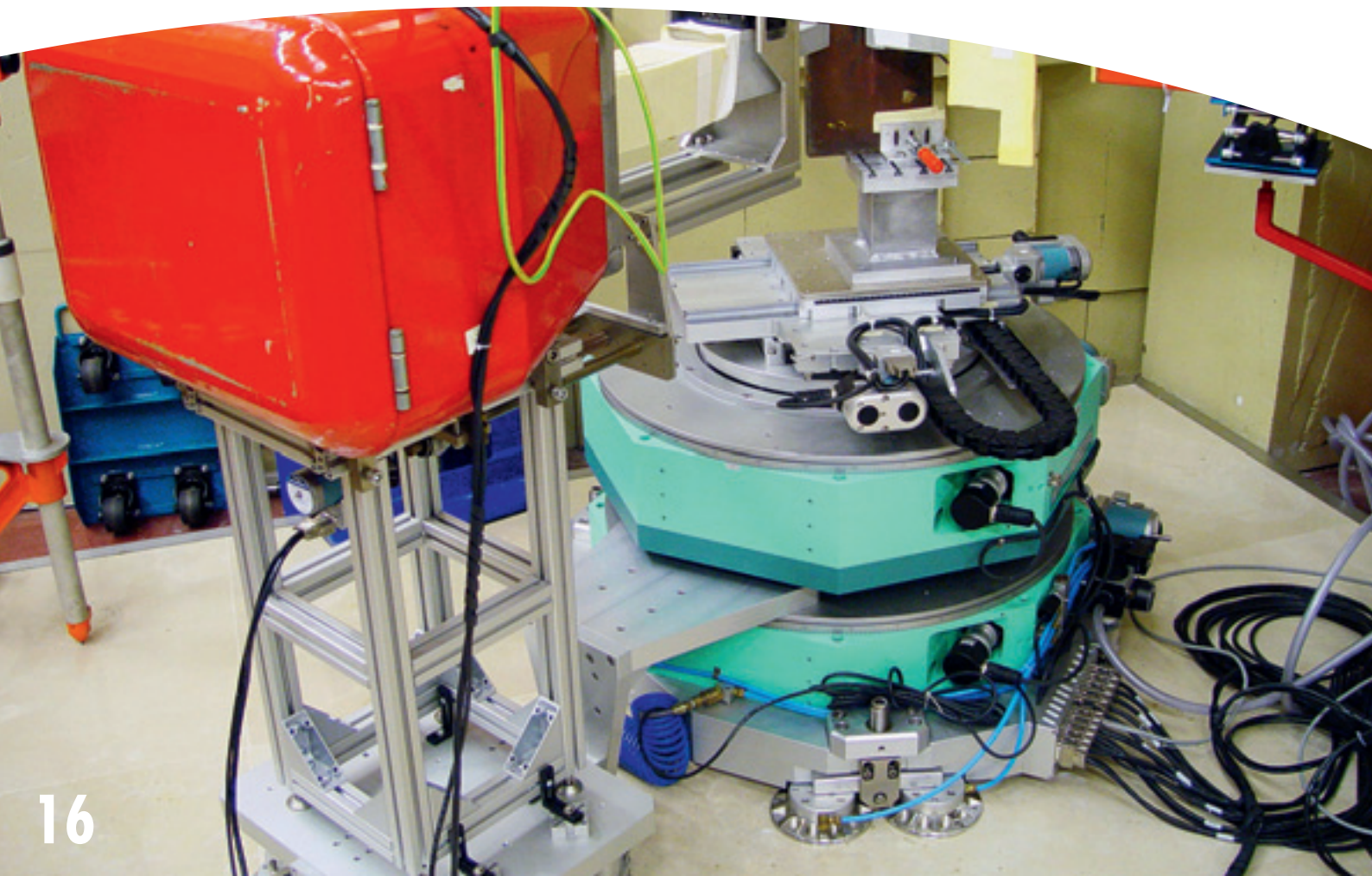

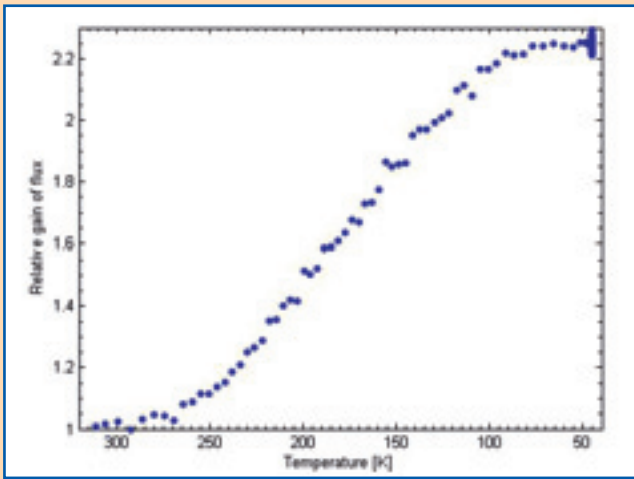

Figure 22 - Flux gain at HFR SANS facility as a result of cooling the Be-filter in the incoming neutron beam

The instrument facilitates handling of much larger specimens in a much more flexible way than the old machine. Specimens of up to 200 kg can be placed and the movement range of the sample positioning tables is now 250 mm. The first measurements performed on NET TG1 and TG2 specimens at the end of 2007 already made good use of these new capabilities. With this installation it is envisaged to also use the second available beam exit when in the future a new neutron monochromator will be installed, so that a very different neutron wavelength can be employed (Figure 21).

HFR Small Angle Neutron Scattering Facility Development

Small-Angle Neutron Scattering (SANS) is a technique used for characterizing sizes (size distributions) and shapes of inhomogeneities in materials and in their mutual interactions. Applications in material science include: nucleation and growth of precipitates and voids, characterization of distributed damage in metals and ceramics as a result of creep and fatigue, microstructural changes after heat treatment and porosity of materials, determination of the properties of colloids and studying multi-phase systems. SANS is currently emerging as a powerful non-destructive method for the investigation of irradiation and thermal ageing induced damage in steel alloys.

The HFR/SANS facility has a range of accessible Q values

between 5×10^{-3} and 0.4 \AA^{-1} , which corresponds roughly to 10 to 1000 \AA in real space. However, the neutron flux at the current HFR/SANS is approx. $10^4 \text{ n cm}^{-2}\text{s}^{-1}$, which constitutes a relatively low flux and its neutron wavelength is fixed at 4.75 \AA . A lot of effort has been put into maximizing the flux at the sample position by a better alignment of the 2 m long monochromator plug and installing the cooling for the Be-filter in the incoming neutron beam. The Be-filter removes from the spectrum neutrons with wavelengths lower than 4.0 \AA in order to prevent higher order reflections in the recorded spectra. However, the absorption cross-section is highly dependent on the temperature with a turning point around 4.0 \AA . This effect is shown in Figure 22. The flux has been increased with a factor of 2.22 when the Be-filter was cooled from ambient temperature to 50 K.

The beam profile before and after alignment of the monochromator plug is shown in Figure 23. These beam profiles have been obtained with a Polaroid neutron camera and the pictures subsequently have been digitized. A new, low cost, neutron camera will simplify such alignment efforts in the future. The neutron beam intensity is now much more evenly distributed. In a SANS experiment, the intensity in the central region is much more important due to collimation of the beam to the central 5-10 mm of the incoming profile. The flux in the central region of a $7.5 \times 7.5 \text{ mm}^2$ is now 3% higher than before alignment of the monochromator.

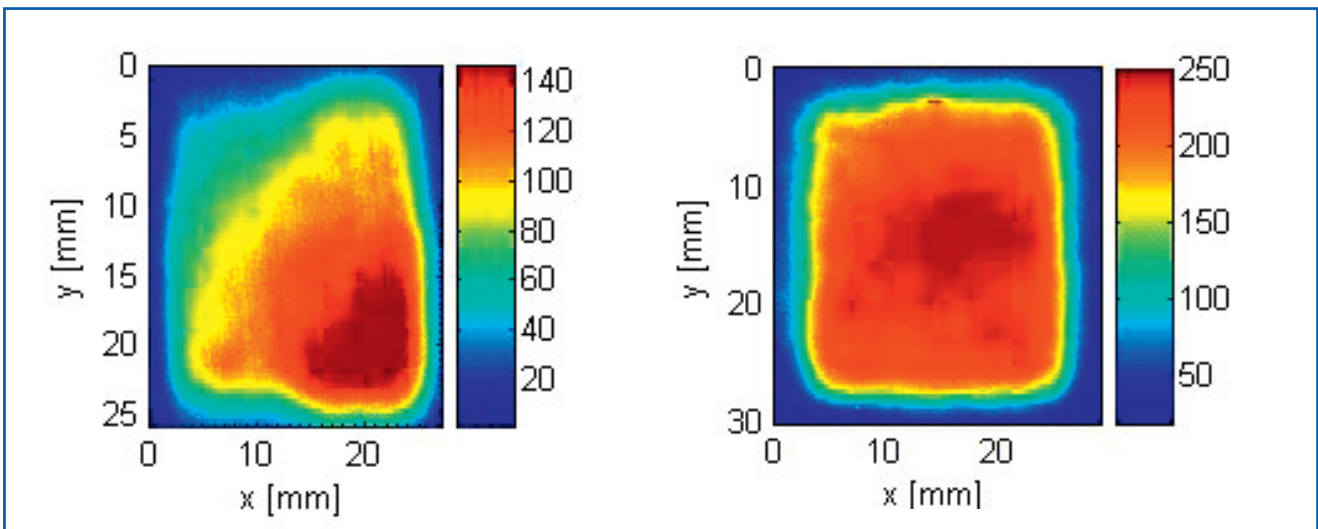
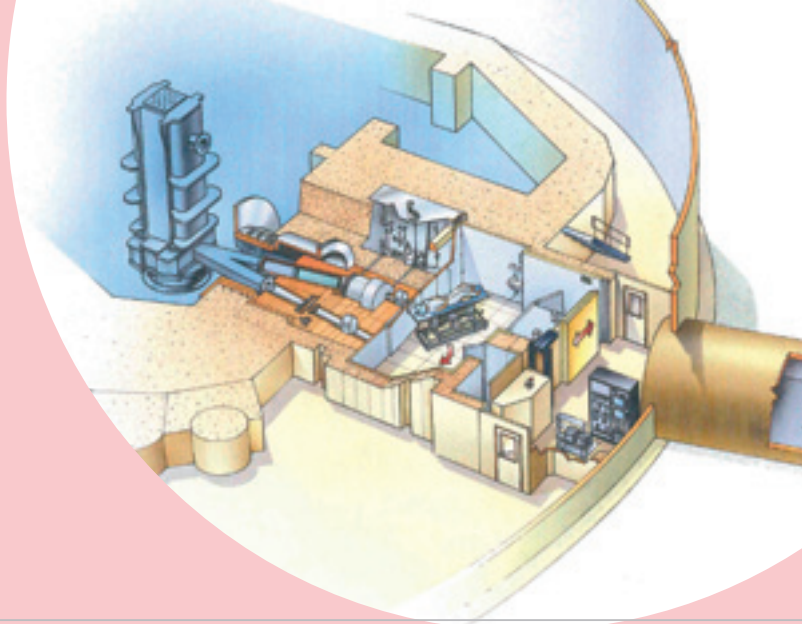

Figure 23 - Beam profiles before (left) and after (right) alignment of the 2 m long monochromator plug at the HFR SANS facility



Medical Applications

BORON NEUTRON CAPTURE THERAPY - BNCT

Background

BNCT is based on the ability of the isotope ^{10}B to capture thermal neutrons to produce two highly energetic particles, i.e. a helium (α particle) and lithium ion, which have path lengths in tissue roughly equal to the diameter of a single cell. Hence, when produced selectively in tumour cells, the particles can destroy the cancer cells, whilst sparing the surrounding healthy tissue. BNCT therefore offers to the clinician the opportunity to limit the damage to the tumour only, which is indicative of its inherent advantages over current advanced radiotherapy techniques applied in conventional radio-oncology units. For the IE, the critical component in BNCT is the availability of a strong, reliable neutron source, i.e. the HFR.

The IE Action on the Development and Exploitation of Neutron Capture Therapy continued to make significant contributions to the development of BNCT in Europe and further afield, and in its educational and dissemination activities. Since the first demonstration of BNCT in Europe in October 1997 at the IE's High Flux Reactor (HFR), and the subsequent development and implementation of BNCT at a number of centres throughout Europe (Finland, Czech Republic, Sweden and Italy), the work at Petten has continued to attract researchers and requests for advice to develop BNCT. Scientists from Poland and Taiwan and nuclear technologists from Bulgaria and Italy were among some of the visitors to Petten on both long-term work assignments and short term need-to-know visits respectively. Research in Petten continued in clinical trials, dosimetry, treatment planning, radiobiology, boron compound testing and looking at other types of cancer, as well as non-cancerous diseases that could be candidates for BNCT. The BNCT educational programme, which started in 2005, continued with more seminars given by external experts on different topics related to BNCT, as well as the co-organisation of international workshops.

Within Europe, BNCT treatment continues in Finland and the development of BNCT facilities continues in Italy, Germany, UK, Bulgaria and Romania. Outside Europe, BNCT treatment of patients is very prominent in Japan and (less so) in Argentina. BNCT projects continue to progress in many other countries, such as Taiwan, USA, Russia, South Korea and China.

The BNCT group in Petten was further strengthened in 2007 with the arrival of a scientist from Taiwan for a stay of 12 months, as part of a Collaboration Agreement between the University of Tsing Hua and IE.

Clinical trials on BNCT at the IE - status

The licence granted by the Ministry of Health (NL) to the Vrije University medical center (VUmc Amsterdam) to perform BNCT at the HFR Petten is currently being renewed. The original licence granted in 1997 has expired and new conditions require a new licence. Consequently, no patients were treated during 2007. Discussions with the Ministries of Health and Economic Affairs in The Hague are progressing with a strong possibility to issue a new licence in 2008. When granted, it is the intention to start trials on the treatment of recurrent Glioblastoma and Head and Neck cancers, under the clinical leadership of Prof. Sauerwein (Essen). There is also interest within The Netherlands and from Sweden to utilise the BNCT facility at the HFR. Of the three clinical trials previously performed (all under Prof. Sauerwein), trial EORTC Protocol 11001 on " ^{10}B -uptake in different tumours using the boron compounds BSH and BPA" has continued during 2007, with tissue and blood samples taken from cancer patients in the operating theatre in Essen and sent to Petten for measurements by prompt gamma ray spectroscopy at beam tube HB7 to determine the concentration of boron in the tissues.

Application of BNCT to other types of cancer - Liver metastases

The application of BNCT to other cancers than brain cancer supplements studies performed elsewhere in the BNCT community, where there is a need to demonstrate that BNCT is indeed a viable therapy for a variety of diseases. Notably in Japan, the application of BNCT is performed for many types of brain tumours, for melanoma metastases at many locations in the body, for head and neck, pancreatic, lung and liver cancer.

With respect to liver, liver metastases are the most frequent kind of malignancy in Western countries (Europe and North America) and represent the most frequent site of recurrence of any primary tumour. Survival of patients with liver metastases depends primarily from the stage of the primary tumour, nevertheless untreated patients invariably have a poor prognosis. Consequently, and due to the success demonstrated in 2001 by the group of Professor Aris Zonta and co-workers at Pavia Italy, who performed extra-corporeal treatment of liver metastases by BNCT, i.e. the liver is removed in the operating theatre, taken to the reactor for BNCT, and then returned to the hospital for re-implantation into the patient, studies are underway at Petten in collaboration with the University Hospital Essen to perform a similar treatment at the HFR.



Figure 24 - Liver surgeon, Dr. Silva Nadalin, testing the insertion of an explanted liver into the Petten holder in the operating theatre in Essen

In 2005, a special facility was designed² and built at Petten to hold the liver during treatment. Tests on the facility were performed in 2006, with a test of the cooling of the facility (the liver will need to be kept at a temperature of approximately 4°C, for over two hours) and with sophisticated dosimetry measurements, including gel dosimetry^{3,4}, to validate the neutron and gamma conditions. During 2007, further tests were carried out at the University Hospital in Essen to place a human liver into the holder, see Figure 24, for later placement into the liver irradiation facility in Petten.

Application of BNCT to non-cancerous diseases – Rheumatoid Arthritis – project status

In 2005, studies started into the possibility to use BNCT to treat rheumatoid arthritis. In these patients, the synovium has turned into an aggressive tissue, invading cartilage and is highly infiltrated by immune cells. Macrophages appear to play a pivotal role in the function of this aggressive synovium. Synovectomy, the removal or killing of this aggressive tissue in patients, is often performed and involves surgery, chemotherapy or radiotherapy and combinations thereof. However,

this approach is seriously hampered by the safety aspects. Macrophages play an important role in the severity of the inflammation process. Hence, selective removal of macrophage activation is a specific approach to diminish local and systemic inflammation, as well as to prevent irreversible joint damage. One possibility is BNCT. In collaboration with the Dutch universities of Delft and Nijmegen, high concentrations of the boron-10 can be achieved using liposomes as the boron carrier. Irradiation tests in 2005 showed very promising results⁵. However, due to a change in the Dutch National regulations, the University of Nijmegen has been unable to receive permission to continue, which will cause a delay in the work until well into 2008.

JRC Institutional Programme on BNCT

The research and development activities of BNCT at Petten are supported in the JRC's Institutional Research programme. The studies into the applicability of BNCT to other types of cancers and non-cancerous diseases are reported above. Other topics, such as treatment planning and improvement of the BNCT facility are continuous actions that have been reported over the years. Other topics include dosimetry, i.e. measurements and calculations to provide knowledge of the radiation characteristics of the incident neutron/gamma beam and to the absorbed dose in tissue, required as a result of the irradiation of a patient, and testing of new boron-containing compounds, by means of cell culture irradiations.

Dosimetry

A campaign of measurements using the so-called paired ionisation technique, principally using TE(TE) and Mg(Ar) chambers, is the subject of one of the BNCT Group's Ph.D. students (Neta Roca, see Figure 25). The technique is standard daily practice in conventional radiotherapy departments. As such, it is recommended for use in BNCT. However, due to the nature of a BNCT radiation beam, which is a mix of neutrons and gammas, the paired ionisation technique is often only applicable, when applied at a fixed position. Furthermore, correction factors to convert the measured signal to dose are subject to high variability and inaccuracies. The measurements performed at the BNCT facility, aim to obtain a comprehensive understanding of the technique, when applied at any position in the beam, whether in a phantom or not. The chambers have been modelled in great detail using the reactor physics code MCNPX. The computational model determines the charge created in the ionisation chamber due to the released electrons. Initial studies to validate the method using photons only (⁶⁰Co) were published in 2007⁶.

⁽²⁾ A. Nievaart, R.L. Moss, J.L. Kloosterman, T.H.J.J. Van Der Hagen, H. Van Dam, A. Wittig, M. Malago, W. Sauerwein: Design of a rotating facility for extracorporeal treatment of an explanted liver with disseminated metastases by boron neutron capture therapy with an epithermal neutron beam. **Radiation Research** 166, 81-88, 2006

⁽³⁾ G. Gambarini, G.G. Daquino, R.L. Moss, M. Carrara, A.V. Nievaart, E. Vanossi, "Gel Dosimetry in the BNCT Facility for Extra-Corporeal Treatment of Liver Cancer at the HFR Petten", **Radiation Protection Dosimetry**, vol 123, Special Issue Neudos-10 (May 2007), 1-6

⁽⁴⁾ G. Gambarini, R.L. Moss, M. Mariani, M. Carrara, G.G. Daquino, V.A. Nievaart, M. Valente, E. Vanossi; "Gel Dosimeters as Useful Dose and Thermal-Fluence Detectors in Boron Neutron Capture Therapy (BNCT)", **J. Radiation Effects and Defects in Solids**, Vol.162, Nos. 10-11, Sept-Oct 2007, 1-7

⁽⁵⁾ P. van Lent, G. Krijger, A. Sloetjes, G. Koning, S. Nievaart, R. Moss, W. van den Berg, "Selective Elimination of Synovial Macrophages by Boron Neutron Capture Therapy prevents onset of Murine Experimental Arthritis", 27th European Workshop for Rheumatology Research, Firenze, Italy, February 22-24, 2007

⁽⁶⁾ Roca, S. Nievaart, R.L. Moss, F. Stecher-Rasmussen, N.V. Zamfir, "Validating a MCNPX model of Mg(Ar) and TE(TE) ionisation chambers exposed to ⁶⁰Co gamma-rays", **Radiation Protection Dosimetry Advance Access** published December 16, 2007, pp 1-7; doi:10.1093/rpd/ncm484



Figure 25 - Positioning check using the laser beam and patient mask prior to dosimetry measurements

As part of this study, measurements were also performed in the Radiotherapy Departments at the local hospital in Alkmaar and at the Queen Elizabeth hospital in Birmingham, UK. In addition, measurements performed in 2006 in Petten with the University of Hamburg led to a new publication⁷.

Radiobiological Dosimetry

Physical dosimetry measurements can be validated by methods of biological dosimetry. This technique relies on estimating the level of chromosomal aberrations in human peripheral blood lymphocytes (PBL) exposed to radiation. Further tests were performed in 2007 at the LFR reactor and in Warsaw. In addition, mathematical codes were developed to predict the dose behaviour^{8,9}.

Cells

More cell culture irradiations were performed in the BNCT irradiation facility as part of the longstanding collaboration with the Universities of Delft and Nijmegen to test new boron compounds for BNCT.

Missions, Symposia and Visitors

Numerous meetings were attended to discuss progress and collaborative actions, as well as organising and/or attending conferences and symposia. These included:

International Symposium on Protons, Ions and Neutrons in Radiation Oncology, July 2007, Technische Universität München

This symposium, jointly organised by the Technical University Munich and University Hospital Essen, looked into the

impact and latest developments of new therapies, especially proton therapy, in comparison to neutron therapies, such as fast neutron therapy (facilities in both Munich and Essen) and BNCT. Both the latter two therapies have taken a back seat to current formidable developments using protons and ions. Nevertheless, neutrons can be used to treat certain tumours in certain stages of disease with good expectation for success. For this reason, they are still being used at the TUM's new research reactor (FRM II) to primarily treat patients with recurrent tumours (breast cancer and ENT tumours) and also patients with salivary gland tumours, pancreatic tumours and malignant melanomas. Moreover, BNCT still offers worthwhile perspectives for scientific investigation and formed an integral part of the symposium. Talks and posters were presented by members of the Petten BNCT group.

International Workshop on "Clinical Trials for BNCT", October 2007, JRC Petten

The workshop was organised jointly by the Institute for Energy/JRC Petten and the University Hospital Essen of the University Duisburg-Essen, sponsored by the JRC's Enlargement and Integration Action (E&IA) and under the auspices of the International Society for Neutron Capture Therapy. The workshop focused on the continuing needs still required before BNCT can be established as a clinical modality to treat cancer. This effort cannot come from a single institute or a small group of enthusiastic researchers but needs the collaboration from all interested parties around the world. One of the aims of the workshop was therefore to summarize the current status of clinical applications with BNCT, to look

^[7] J. Becker, E. Brunckhorst, A. Roca, F. Stecher-Rasmussen, R. Moss, R. Böttger and R. Schmidt, "Set-up and calibration of a triple ionization chamber system for dosimetry in mixed neutron/photon fields", *Phys. Med. Biol.* 52 (2007) 3715-3727

^[8] Josselin Morand, Joanna Deperas, Witold Urbanik, Raymond Moss, Sabet Hachem, Wolfgang Sauerwein and Andrzej Wojcik, "Confidence limits for Neyman type A-distributed events", *Radiation Protection Dosimetry, Advanced Access*, Published in October 2007 (to appear in 2008)

^[9] Joanna Deperas, Marta Szłuińska, Marta Deperas-Kaminska, Alan Edwards, David Lloyd, Carita Lindholm, Horst Romm, Laurence Roy, Raymond Moss, Josselin Morand and Andrzej Wojcik; "CABAS - a freely available PC program for fitting calibration curves in chromosome aberration dosimetry", *Radiation Protection Dosimetry* 2007 124: 115-123; doi:10.1093/rpd/ncm137



Figure 26 - Participants at the International Workshop on "Clinical Trials for BNCT", October 2007, JRC Petten

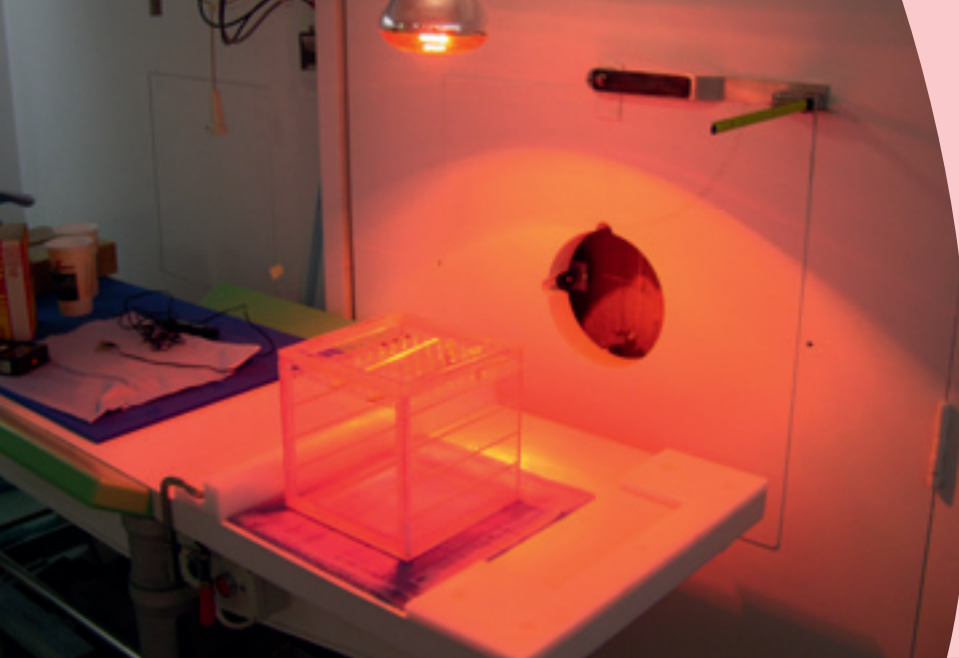

Figure 27 - Irradiation of cells under infra-red heating at the BNCT radiation facility

on promising trial designs and strategies and to identify the type of tumours that should be targeted in future trials. The organizers also discussed their own strong interest on the possibilities on how to continue patient treatments in Petten. The workshop attracted almost 50 participants, including guests from outside Europe (Japan and Taiwan).

European Workshop, "Boron Analysis and Boron Imaging for BNCT", Bucharest, November 2007

The meeting was organised jointly by the Institute for Energy/JRC Petten, University Hospital Essen of the University Duisburg-Essen and the Institute for Nuclear Research & Nuclear Energy in Bucharest and sponsored by the JRC's Enlargement and Integration Action (E&IA) and under the auspices of the International Society for Neutron Capture Therapy. The workshop focused on one of the critical prerequisites in Boron Neutron Capture Therapy (BNCT), namely: knowledge on the boron-10 concentration, and its intra- and inter-cellular distribution in tissue, including blood. As such, a wide range of European experts were invited to Bucharest to present the many aspects of boron measurement. The workshop also looked at standards, which have not yet been established, in order that the results coming from the different methods can be compared and used correctly for BNCT. Over 60 participants were present. The workshop included satellite meetings on boron standards and an executive meeting of the ISNCT. It was concluded that in order to come to a standard method, a multi-centre measurement should be performed, comparing the boron-concentration measurements in tissue. The tissue to be used would be from actual cancer patients. The general consensus was that this workshop had been extremely useful and thanks were given to both the JRC for the funding provided by the Enlargement and Integration Action and to the local organisers in Bucharest.

Workshop for Young Researchers in BNCT, Birmingham, UK

This biennial meeting is intended for the PhD researchers in BNCT around the world. The meeting was attended by the four young researchers from Petten, each of whom gave presentations on their work. Some 50 participants were present representing many of the BNCT programmes from around the world including Russia, Argentina and USA.

Workshop on Diamond Fingerprinting, October 2007, IRMM, Geel

As a spin-off of one of techniques used in BNCT, namely Prompt Gamma Ray Spectrometry, an invitation was received to participate and present the technique at an expert workshop on the feasibility of source region identification of conflict diamonds using analytical techniques organised by DG RELEX and JRC-IRMM. To avoid illegitimate trade in diamonds, internal controls are required from mine to export, to ensure that only legitimate diamonds are exported. The workshop had the objective to clarify, as far as possible, whether a feasibility study should be realized in order to experimentally determine if source region identification of diamonds, using analytical techniques, is possible. One possible technique is neutron activation analysis, which is available as one of the techniques used in the BNCT project to measure boron concentrations in tissue. The technique was presented by Dr. Finn Stecher-Rasmussen, consultant to the Petten BNCT Group.



Figure 28 - [In Memoriam] Prof. Schmidt (Hamburg University) taking measurements at the Petten BNCT facility in 2006 [Prof. Schmidt passed away early 2008]



IAEA Technical Expert: Institute for Nuclear Research and Nuclear Energy (INRNE), Bulgarian Academy of Science, Sofia, Bulgaria

The Action Leader (R. Moss) was invited as an IAEA Technical Expert to give a week's course on BNCT in Bulgaria. Some 30 participants were present. The course included a visit to the research reactor at the institute, where BNCT is planned, and interviews on Bulgarian TV.

International Workshop on "Nuclear Data for Science and Technology: Medical Applications", November 2007, Trieste

Amongst other actions, first contacts with Third Country representatives were initiated with the participation at the Workshop, which was organized by IAEA and held at the International Centre for Theoretical Physics, which is part of UNESCO. The participants were coming from several Third Countries, among them Argentina and India, who showed a great interest towards BNCT.

Visitors

Visitors to Petten to discuss BNCT and possible collaborations included representatives from Comitato EUROSEA, Torino (on the development of a neutron generator for BNCT), Leiden University (on a joint project to treat liver cancer), Halle University Germany (visit of the Medical Physics department), and the Institute for Nuclear Research and Nuclear Energy, Bulgaria (as part of the agreement under the IAEA contract).

EDUCATIONAL AND DISSEMINATION ACTIVITIES

Seminars in 2007

The educational programme for young BNCT researchers continued with seven seminars organised in 2007 and held at IE Petten. The invited speakers covered a wide variety of topics related to the disciplines of BNCT. For the programme of 2007, see the table below.

Dissemination

Two articles on BNCT following interviews with journalists appeared in the Dutch national newspapers: Financieel Dagblad and De Telegraaf.

Publications

The BNCT group wrote and co-authored nine peer-reviewed papers in 2007.

Ph.D. success

During the course of 2007, Sander Nievaart (Ph.D. student in the Petten BNCT Group) was awarded his doctorate by the Delft University of Technology. His thesis was entitled "Spectral Tailoring for Boron Neutron Capture Therapy"¹⁰.

⁽¹⁰⁾ Nievaart, V.A., "Spectral Tailoring for Boron Neutron Capture Therapy", Ph.D. Thesis, Delft University, IOS Press, ISBN 978-1-58603-762-8 (2007)

Month	Name	Institute	Title of Talk/Presentation
February	Prof. Hans Zoetelief and Xander Rijkee	IRI, Technical University of Delft, The Netherlands,	Induction of new primary tumours after conventional radiotherapy and IMRT of prostate tumours
March	Prof. Andrzej Wojcik	University of Kielce, Poland	Biological basis of Radiotherapy
April	Prof. Barry Allen	University of Sydney, Australia	Dosimetry and dose distribution in alpha-immunotherapy
May	Dr. Steven van der Marck	NRG, Petten, The Netherlands	ORANGE, a tool to calculate dose distributions
June	Dr. Nina Steckel	University Hospital Essen, Germany	Patient Care in Oncology
July	Prof. Francesc Salvat	Universitat de Barcelona, Spain	PENELOPE. Specific features and applications
September	Prof. Ben Slotman	VU medical Center Amsterdam, The Netherlands	4D stereotactic radiotherapy for lung cancer



MEDICAL RADIO-ISOTOPE PRODUCTION

In 2007 the HFR again demonstrated its essential role as the largest producer of medical isotopes in Europe. The total volume and value of isotopes supplied from the HFR grew again in 2007 to new record levels. This was achieved despite the loss of two weeks (approx. 5%) of production time due to technical problems with the reactor.

The supply of the main medical isotopes, in particular Molybdenum/Technetium continued to grow and during 2007 an additional in-core Molybdenum production rig was added to the production capacity. This brings the total of fixed in-core facilities to three and these continue to be supported by a large number of pool-side Molybdenum production facilities that can be deployed in a flexible manner during the reactor cycles. The production levels of Molybdenum and isotopes in general are constrained by the total workload on the HFR for all experiments. This total workload continues to grow; driving the need to increase the operating efficiency in all areas of activity.

The HFR operated as the only major Isotope Production Reactor (IPR) in Europe for a record level of more than 100 days during 2007. However, during December 2007; the staff and facilities were called upon to perform extraordinary duties when the Canadian NRU Reactor was unexpectedly unavailable. For a period of around one week the HFR was the only major IPR operating in the world and during that HFR cycle, Molybdenum production was doubled in an effort to maximise the supply of material to the worldwide market. During that period emergency planning efforts were quickly put into place to position the HFR ready to provide (for a short term period) a further 30% increase in Molybdenum irradiation capacity. Ultimately the situation in Canada was resolved and the additional emergency measures were not introduced; which was fortunate as the action would have had significant disruptive effects on other HFR programmes.

During 2007, a number of new developmental programmes continued to make good progress and an interesting range of potentially new therapy products started out into early developmental phases. On the negative side, a number of key customers decided to discontinue the production of some older therapy products and to stop an important research isotope. These losses for the year were offset with growth in other areas and by switching utilisation of production facilities.

In the industrial isotopes area, growth was more limited as the production capacity for these products is full. Some growth was achieved by the conversion to enriched target materials to use the possibility of increasing production efficiency from the same base capacity. This general trend of target conversion had positive progress through the year.



Fission Reactor Technology

HIGH TEMPERATURE REACTOR FUEL IRRADIATIONS

Background

The High Temperature Reactor (HTR) is a gas-cooled graphite moderated nuclear reactor concept. The high temperature coolant output, effective fuel use, large R&D experience and robust safety concept make it a very attractive heat and power generating system. The HTR is specifically intended for deployment in an industrial environment.

HTR fuel consists of TRISO-particles which are uranium oxide kernels coated by a porous graphite buffer layer and a pyrocarbon-siliconcarbide-pyrocarbon coating. 10,000-14,000 of these particles (1 mm diameter) are contained in a graphite matrix in the form of a 6 cm diameter fuel sphere ("pebble") or in the form of finger-thick cylinders ("compacts").

Two irradiation tests of low-enriched uranium fuel types in the HFR were carried out or further prepared to determine their limits with respect to radioactive fission product release with increasing burn-up (enhanced fuel use) and at increased fuel temperature (enhanced efficiency).

Work performed in 2007 was marked by three events:

1. HFR-EU1bis

Further Post-Irradiation Examination (PIE) and safety testing of fuel pebbles irradiated in 2004-2005 in the HFR-EU1bis irradiation were performed.

After irradiation, the HFR-EU1bis fuel pebbles were transported from the HFR to the NRG hot cell labs on the Petten site. Currently PIE is being completed comprising:

- dismantling;
- metrology;
- gamma scanning of graphite shells and pebbles;
- weighing;
- visual inspection of the pebbles;
- gamma-scanning of the outer stainless steel containment (to confirm burn-up calculations);
- X-ray photography;
- neutron metrology on the fluence detector sets;
- ceramography on one pebble;
- electron probe micro analysis (EPMA) on the same pebble.

The diameter of the pebbles was measured in three perpendicular axes. Diameter change compared to the initial values is shown in Table 4.

The average diameter decrease is 1.29 mm (2.16%), corresponding to a 6.3% volume decrease. As expected, the pebbles having received the highest fast fluence show the most significant shrinkage. Comparing the diameter decreases of the three axes revealed that the "hot" axis, in line with the central vertical axis of the sample holder, showed approx.

Pebble	Average shrinkage in 3 dimensions [mm]	Fluence ($E > 0.1$ MeV) [10^{25} m^{-2}]
HFR-EU1bis/1 (top)	-1.18	3.02
HFR-EU1bis/2	-1.25	3.64
HFR-EU1bis/3	-1.36	3.98
HFR-EU1bis/4	-1.37	3.82
HFR-EU1bis/5 (bottom)	-1.30	3.44

Table 4 - Average diameter shrinkage vs. fast fluence

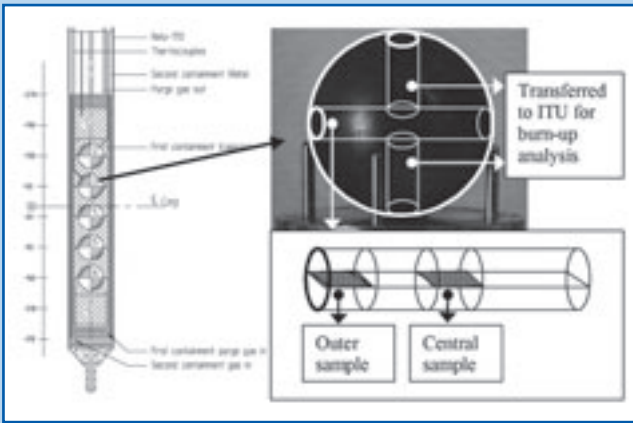

Figure 29 - Sample preparation for PIE

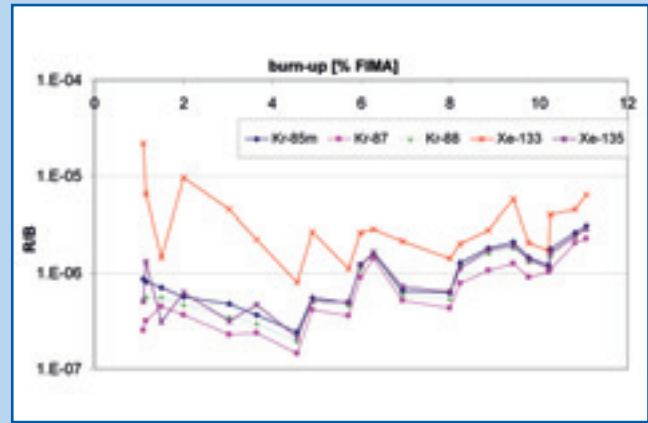

Figure 31 - Final R/B vs. burn-up

0.2 mm smaller diameter decreases than the other two axes where strong negative temperature gradients existed. This is quite exactly matching predictions from the so-called "Kania Model".

Gamma scanning of the graphite half shells allowed detecting a significant amount of ^{110m}Ag , ^{134}Cs and ^{137}Cs . A quantitative analysis of the release fractions of these isotopes is ongoing. Gamma scanning of the pebbles exhibited significant inhomogeneities in the coated particle distribution inside the pebbles.

Visual inspection of the pebbles showed that their shiny surface was maintained hinting at the absence of corrosion phenomena. After initial PIE, four of the five pebbles were transported to JRC-ITU for KÜFA testing in February 2007. One pebble was prepared for destructive examination as shown in Figure 29. Examination of this sample included ceramography, electron probe micro analysis, ion etching as well as hardness measurements of coatings and kernel. An example of detailed ceramography of one TRISO-particle at the outside of the fuel pebble is shown in Figure 30. So far, the performed PIE has provided significant information for the application of HTR fuel at high temperatures and high burn-up. Additionally, a number of innovative PIE techniques targeting specifically irradiated HTR fuel are being developed.

The achieved burn-up was measured to be < 11% instead of the intended 15%. In fact, the experiment had been terminated somewhat early due to an error in neutronics data post-processing. The burn-up was confirmed by additional detailed neutronics calculations taking due account of the irradiation history. After correction of this data, the final result of R/B vs. burn-up is plotted in Figure 31. The R/B fraction is the ratio between fission gas release ("R") and fission gas birth ("B") which is traditionally used as a characteristic health indicator for HTR fuel particles.

Even considering the very high irradiation temperature, these R/B values are unusually elevated. In fact, most HTR fuel tests exhibit R/B of the order of 10^{-8} , which is attributed to very small uranium and thorium impurities in the employed graphite. In HFR-EU1bis, it can be concluded that one or several of the 50,000 fuel particles was defective from the start of the irradiation. The early R/B values indicate clearly that this defect existed already at the beginning of irradiation, so that it is not the irradiation itself which has caused damage to the fuel. Further data analysis is ongoing. Additional burn-up measurements and safety testing (at JRC-ITU) will be performed in early 2008.

2. HFR-EU1

This irradiation test with a slightly lower central pebble temperature but a higher target burn-up was continued throughout 2007. Using detailed neutronics calculations, a definite position in the HFR could be found constituting a compromise between irradiation duration and acceleration factor. The target burn-up had to be decreased from 20% to approx. 15% due to otherwise excessive duration of irradiation. The relatively high failure rate of thermocouples may turn out to be the limiting factor. The fuel itself shows good quality confirming extremely low fission gas release with R/B of the order of 10^{-8} .

3. HFR-PBMRF1

Preparation of this irradiation for the South African PBMR prototype project was continued in the frame of a bilateral cooperation agreement. While fuel delivery had to be postponed to 2008, the time was used to improve the design, in-pile instrumentation of the rig as well as the gas analysis system. Start-up of the experiment is foreseen by mid-2009.

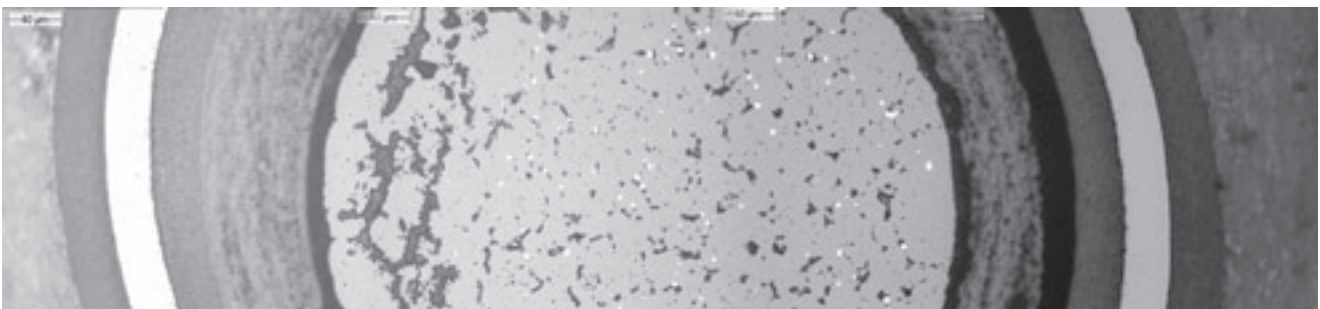

Figure 30 - Detailed ceramography of irradiated TRISO particle

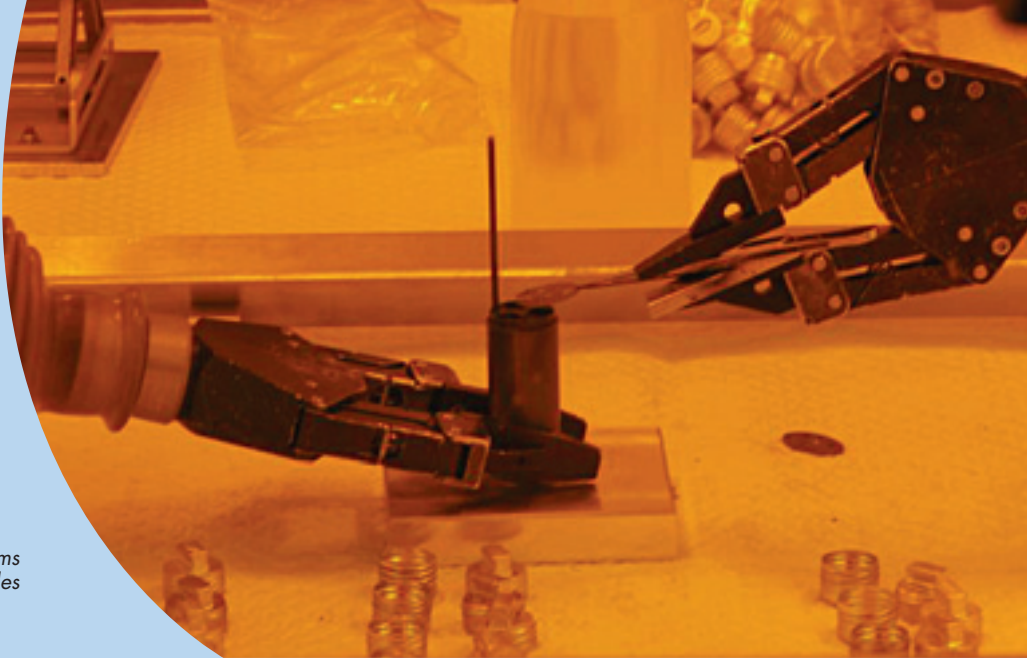

Figure 32 - Loading of the drums with irradiated samples

HTR CORE STRUCTURES GRAPHITES

For High Temperature Reactors, graphite is the structural material supporting the reactor core. As the development of this reactor type jumps from the Generation I prototypes to the Generation III+ modular concepts of today, without a commercial Generation II, the graphite manufacturers of the early days are not available anymore. New graphite types need to be developed and qualified, and several manufacturers are already involved.

An inevitable part of this trajectory is the irradiation test in a materials testing reactor. Within the European Framework Project RAPHAEL, NRG plays a leading role in the research for graphite behaviour for high-temperature reactors (Figure 32 - Figure 34). Irradiation tests take place in the HFR at different temperatures. After this, properties, such as dimensions, elasticity, thermal expansion coefficient and thermal diffusivity are determined. These properties are changing considerably and non-linearly under the influence of neutron irradiation. As the graphite, in the form of reflector bricks or as structural material, remains in the reactor for very long periods of time, it is important to be able to predict these properties accurately.

A first irradiation experiment at a relatively low temperature and low dose (750°C, 8 dpa) was executed in 2004 and 2005. It contained 160 specimens from eight different graphite types from various manufacturers from Germany, the United States and Japan. In 2007, half of these irradiated samples have been reloaded in a second experiment for further irradiation, up to 24 dpa. As the construction of this experiment had to take place in a hot cell, new assembly techniques had to be developed. In August 2007, this second irradiation experiment has been started, in which three new graphite types have been added. An initial irradiation experiment at a higher temperature (950°C) has been completed in June of 2007 for the low dose, and will be partially reassembled in a second irradiation experiment in 2008.

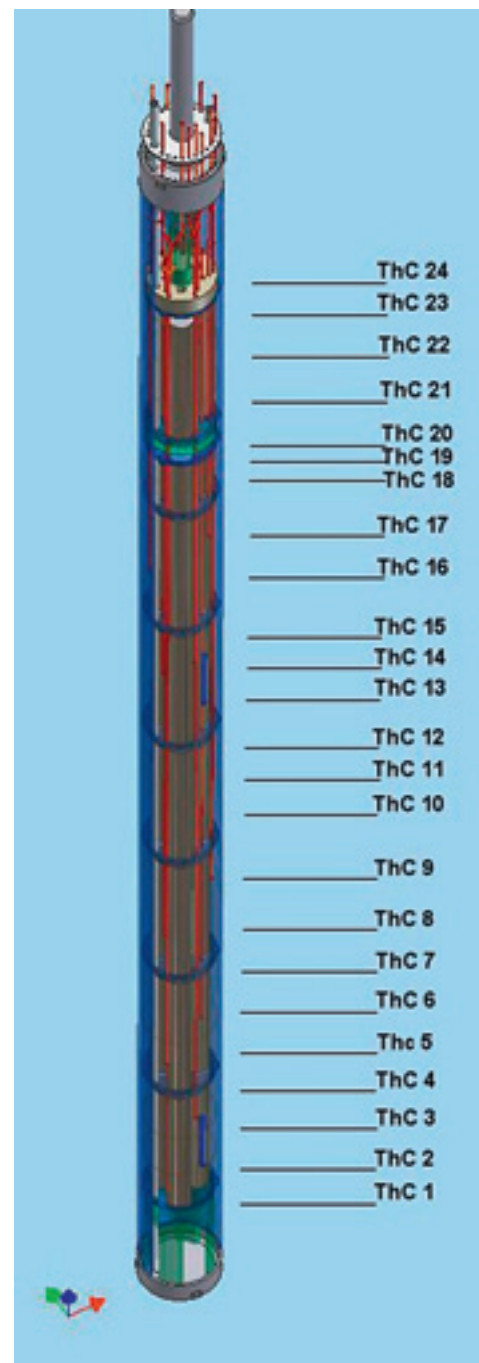

Figure 33 - Schematic presentation



IRRADIATION OF HTR VESSEL MATERIAL AND POST-IRRADIATION TEST

Objectives

One of the alternatives considered for HTR is the application of the so-called hot-vessel. Modified 9Cr-steel could potentially be used up to 450°C. Thick-section weldments have been produced by Framatome ANP for reference, irradiation and post-irradiation testing of weldment and base metal.

Achievements 2007

The irradiation of specimens cut from a T91 weldment was performed in 2005. Longer term post-irradiation creep tests for the FP6 RAPHAEL programme followed. These tests were performed with target rupture times in the range of 10^3 - 10^4 hrs. In 2007 three long term post-irradiation creep tests have been finished. New tests are started and will run for 5,000 to 10,000 hours.

Figure 34 - Assembly of the experiment for graphite irradiation



Fusion Reactor Technology

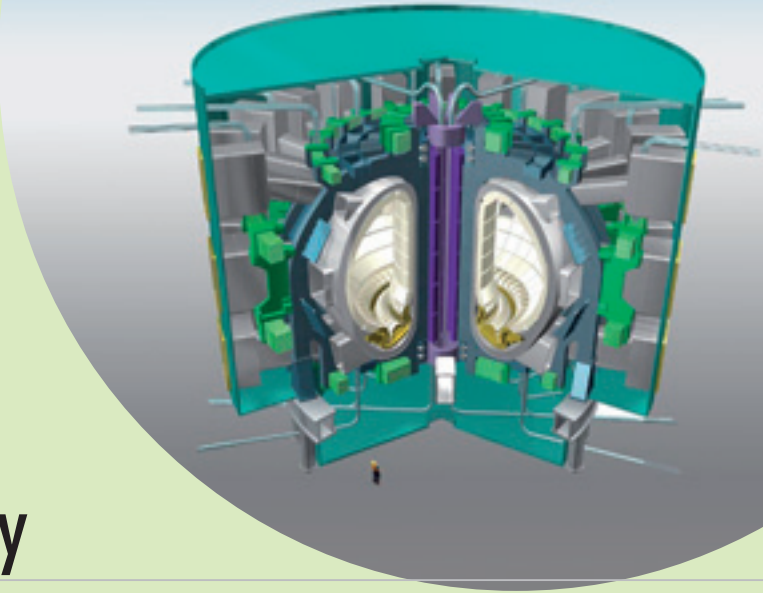

HFR's high versatility provides extremely relevant R&D capabilities for fusion power plant technology. The HFR contributes to the fusion technology development by providing experimental results utilising the HFR as the neutron source and the hot cell laboratories to perform post-irradiation testing. The main areas of interest are the ITER vacuum vessel, the development of high heat flux components and blanket structures, and the development of the reduced activation materials: 9-Cr steels and innovative materials such as fibre reinforced composites.

In addition, irradiation behaviour of ITER diagnostic instrumentation and the in-vessel parts of heating systems require dedicated assessments and testing programmes. As part of the qualification of materials supporting the licensing of a future reactor, the design of the International Fusion Materials Irradiation Facility (IFMIF) is under development. The HFR provides ample opportunity to qualify specific materials for the IFMIF target section, instrumentation and mock-ups. Presentations of the activities on ITER, DEMO and the roles of HFR were delivered to the top Fusion Symposia and Conferences.

ITER Vessel/In-vessel

In one of the European design concepts, the ITER first wall panels are attached to the blanket modules by bolts. NRG investigates the behaviour under neutron irradiation of PH13-8Mo as candidate material. The irradiation campaign aims to measure the response of this material in terms of yield stress hardening, elastic fatigue resistance and fatigue crack propagation up to 2 dpa. The irradiation performed is a SUMO-type experiment, modified to have two temperature zones at 200 and 300°C. The irradiation and dismantling was completed, and the post-irradiation examinations started in 2007.

NRG assisted the ITER Central Team in updating the ITER Materials Properties Handbook (MPH). This includes reviewing and assessing irradiation effects on fracture mechanics properties of powder HIPped ITER grade 316L(N) stainless steel.

A new test facility for ITER primary wall modules is under construction, which will allow close simulation of thermal fatigue and simultaneous neutron loading in the HFR pool side. NRG also developed with TNO alternative manufacturing routes for thick tungsten claddings on copper-base substrates.

Explosive forming of thick stainless steel sections was demonstrated by Exploform BV, in a joint effort with NRG and TNO to provide alternative manufacturing solutions for the ITER vacuum vessel. Further tests and qualification works are ongoing.

Figure 35 - In-pile differential temperatures in one of the pebble-bed assemblies, for two diametral orientations S and N. The slow decrease of these temperature drops follows the gradual decrease of generated power in the breeder section. There is some indication of a gradual increase of the beryllium beds conductivity.

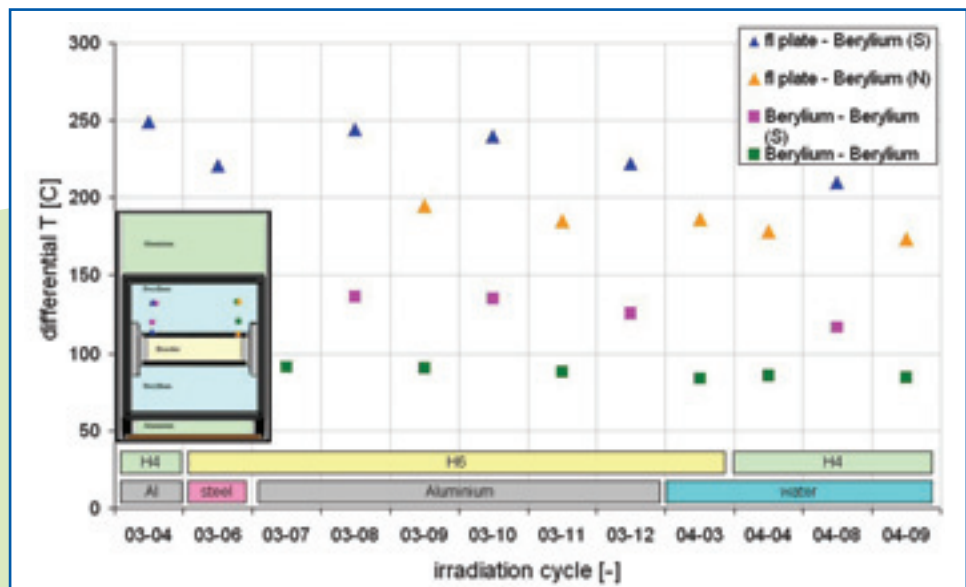

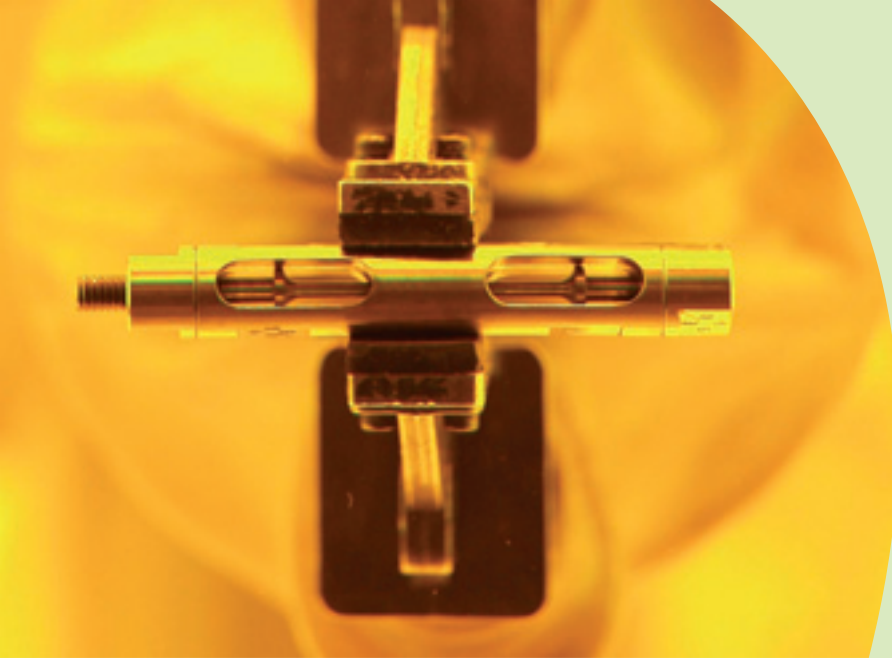

Sub-modules for the Helium Cooled Pebble Bed Concept

For fuelling of the first generation power plants based on fusion of deuterium and tritium, the latter has to be produced by transmutation of lithium through the neutrons generated in the plasma. Present blanket designs consider solid, as well as liquid lithium compounds, combined with a neutron multiplier. ITER will serve as a test bed for Test Blanket Modules (TBM), which will provide input for the design of blankets for the Demonstration fusion reactor (DEMO) and for later fusion power plants. Such a TBM also closely needs to follow the design of blankets for DEMO and fusion power plants. The neutron spectrum in the HFR forms a realistic environment for the testing of blanket sub-modules.

Four helium-cooled pebble bed assemblies with lithium-silicates and lithium-titanates, which closely resemble the major design for ITER's intended TBM, were tested in the HFR to the relevant neutron fluence level. In-pile differential temperatures were analysed for two diametral orientations of the pebble-bed assemblies. There is some indication of a gradual increase of the conductivity of beryllium beds, which is being quantified through modelling support.

In 2007 three of the four modules were dismantled and detailed post-irradiation examinations followed. The Post Irradiation Examinations (PIE) provided evidence of sinter-necking of pebbles, an effect that eventually may lead to gap formation at the pebble-bed wall interface.

In addition, a great deal of information can be gathered on material compatibility and TBM relevant instrumentation issues. In addition, modelling has supported analyses of in-pile performance data.

Functional Fusion Blanket Materials

In the EXOTIC (EXtraction Of Tritium In Ceramics) series, irradiation of meta-titanate pebbles from CEA (F) continued. The experiment EXOTIC-9/1 focuses on in-pile tritium release characteristics. In addition, the effect of in-situ oxidation on the permeability of Eurofer-97 has been experimentally simulated with moisturised purge gas. The principle methodology for in-situ oxidation of components for gas-cooled reactors was demonstrated. In-pile operation was concluded, and dismantling and start of post-irradiation examinations were scheduled for 2008.

Preparation of the HICU experiment (High-fluence Irradiation of breeder Ceramics), aimed at long-term (up to two years) irradiation of ceramic pebbles, was successfully completed. Following the HEU-LEU conversion of the HFR, uncertainties in the design have been reduced, and the manufacture of the neutron screen and assembly of the specimen stacks could

be realised as foreseen. Selected stacks were scanned with the advanced X-ray tomography technique at the University of Manchester. In-pile operation of HICU was successfully started in February 2008. HICU is expected to deliver key properties for definition and selection of grades to be used in the ITER TBM programme.

The objective of the HIDOBE (High Dose Beryllium irradiation) project is to quantify the long-term behaviour in terms of swelling, creep and tritium retention and validate preliminary model descriptions. Beryllium pebble stacks are irradiated in the HFR for a 2 and a 4-year period. In the framework of the IEA implementing agreement on Radiation Damage Effects in Fusion Materials, partners in the EU, Japan and the Russian Federation provided different grades of beryllium specimens. The first of these two high dose irradiations of beryllium specimens, HIDOBE-01 was ended on achieving its target dose of 3,000 appm helium towards the end of 2007.

The experiment contained a few piggy-backs of ceramic breeder pebbles, complementary to the shielded HICU case. It will be dismantled in 2008. HIDOBE-02 will continue in 2008 and 2009.

In the area of lithium, lead-based, blanket concepts, in-pile operation of LIBRETTO-4/1 and 4/2 rigs continued, after a longer outage resulting from the failure during unloading of a neighbouring experiment. These are aimed at the permeation characteristics of Eurofer tubes under relevant irradiation parameters, in nominal 350°C and 550°C regions. The Tritium Measurement Station (TMS) is used to monitor and control the experiment. Both first and second containments are swept with a He + 1000 ppm H₂ gas flow for tritium extraction. This allows direct comparison of tritium production and permeation.



Figure 36 - The as-irradiated stack of four subsized blanket modules with containments and instrumentation prior to dismantling.

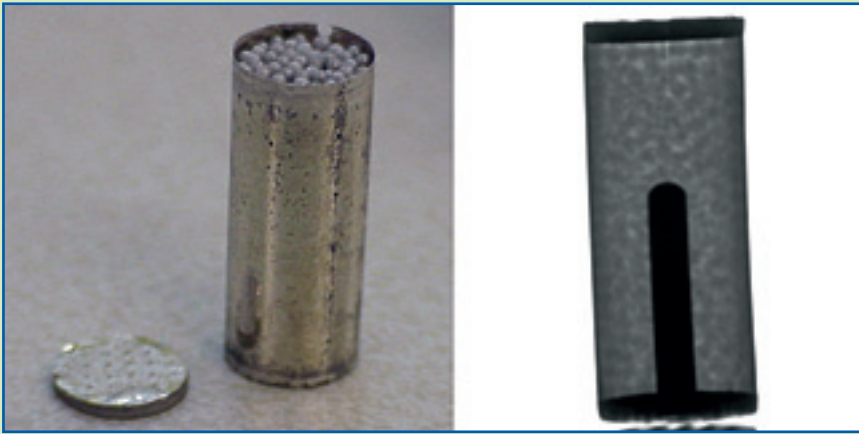

Figure 38 - Miniature pebble-bed with platinum foil around to prevent chemical interactions with the Eurofer structures (left) and 2-dimensional X-ray picture of miniature pebble-bed with thermocouple tube allowing peak temperature measurements during irradiation (right).

The LIBRETTO-5/1 experiment was loaded in the HFR during the second half of 2007. The objective is to provide experimental evidence of the effect of nano-size helium bubble formation on the tritium extraction rate. Such a phenomenon may affect the handling of higher tritium inventories of ITER TBM's and DEMO blanket concepts.

Structural Steel for ITER Test Blankets

Ferritic, martensitic steels have become the reference structural steel for blankets. An advantage of such steels is that, providing the impurity level can be controlled, they can be made with alloying elements that allow re-processing after less than 100 years. Manufacturing of such alloys has been successfully demonstrated by the Japanese and EU steel industry. This class of steels is called Reduced Activation Ferritic Martensitic (RAFM) steel.

A complete set of irradiation projects with post-irradiation testing is necessary to qualify this steel for application in blankets. The work performed at NRG's Hot Cell Laboratories, includes for example tensile testing, irradiation creep, fracture mechanics, low-cycle fatigue and fatigue crack propagation with hold-times.

The SUMO-09 irradiation was aimed at small size specimen

technology and crack-propagation in sandwich systems with compliant layers. The rig had three temperature levels (250-300-350°C) and reached 2.5 dpa. Two STROBO rigs delivered stress relaxation data up to 1 and 2.5 dpa. Nearly all post-irradiation testing could be performed, and results will be available in 2008.

Two new irradiations were started for the irradiation characterisation of the European Eurofer ODS reference batch up to 2.5 dpa. These SUMO-type capsules were manufactured for three temperature levels (300-450-500°C).

Advanced Materials

While significant work is still ongoing to qualify materials for the ITER machine and its internals, in support of the construction and operation licence, further improvement of component performance should arise from the R&D on innovative materials and technologies. Such innovations may be in time for use at the start of ITER or be applied for the second batch of replaceable components, such as the divertor and first wall.

Similarly, the insertion of the Test Blanket Modules in ITER will require the qualification of structural and functional materials for the expected loading conditions. Qualification

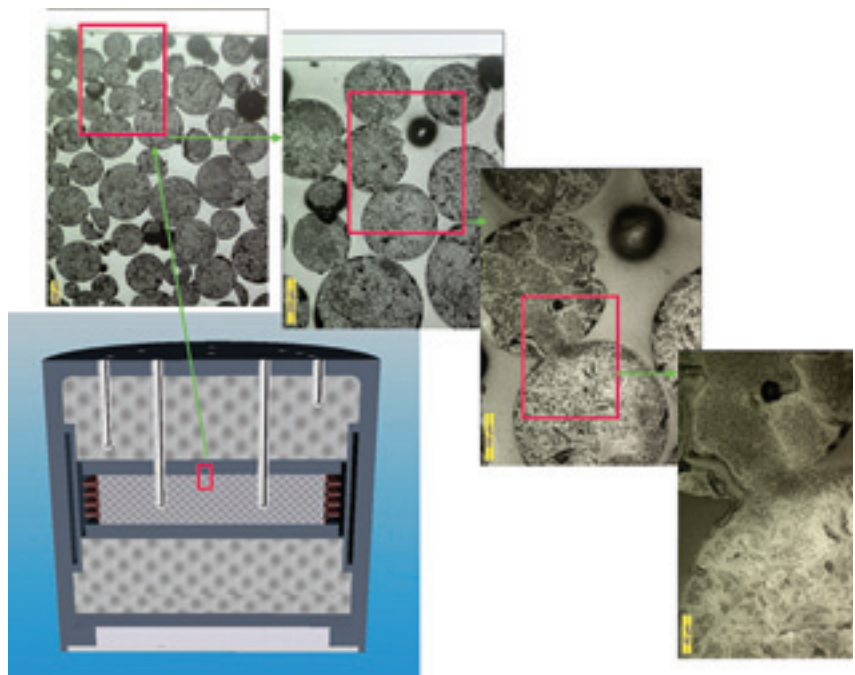

Figure 37 - Schematic of cross section of a PBA test-element with ortho-silicate pebbles, after irradiation

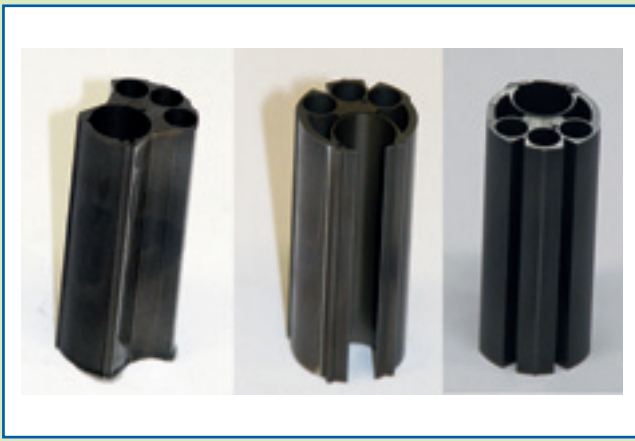

Figure 39 - Various designs for the HICU specimen holders, machined by EDM



Figure 40 - Typical test specimens of carbon, silicon carbide, tungsten, fiber reinforced copper, and miniaturized divertor elements, from various ExtreMat project partners, before irradiation at different temperature and dose levels

of these materials for use in DEMO and fusion power plants will require very extensive testing programmes, including the verification of spectrum effects that cannot be dealt with in present test facilities. For the blanket and divertor in DEMO there is growing interest in ODS ferritic steels and tungsten. SiC/SiC composite structures show good potential for devices beyond DEMO.

The goal of the European Integrated Project "EXTREMAT" is to provide and to industrialize knowledge-based materials and their compounds on a commercial scale for applications in extreme environments, in particular those that:

- provide durable complex protection mechanisms for sensitive structures operated in physico-chemical environments at high temperatures;
- provide the capability of removing extreme heat fluxes, often at very high temperature levels;
- can endure radiation doses beyond the capability of materials now available;
- can be processed into complex heterogeneous compounds that can be operated in extreme environments.

Key applications for these new materials are in the sectors of fusion, advanced fission, space and electronic applica-

tions. The project involves 37 industries, research institutes and universities, started in 2004 and is supported by the European Community (non-Euratom).

Within the area of radiation resistant materials, the EXTREMAT Project focuses on ferritic steel with Oxide Dispersion Strengthening (ODS), and nano-grained tungsten by Severe Plastic Deformation (SPD). These materials aim at operational temperatures well above 600°C, possibly 1100°C for tungsten. Some miniaturized divertor mock-ups were included with novel joining technology.

In ceramics the focus is on graphite structures with dopants, Carbon Fiber Composites (CFC), SiC from nano-powder and composites (SiCfSiC).

The testing programme at Petten concerns two irradiations that start in the first half of 2008. Targets are a peak 5 dpa at temperatures 550-950 °C and peak 2-3 dpa at 300-600°C, both in inert (helium) environment. The key issues addressed are tensile and fracture properties for the metallics, and dimensional stability, thermal expansion and thermal conductivity for most ceramics. Limited space is available for coated and bonded specimens. Post-irradiation testing will be performed in 2008-2010.

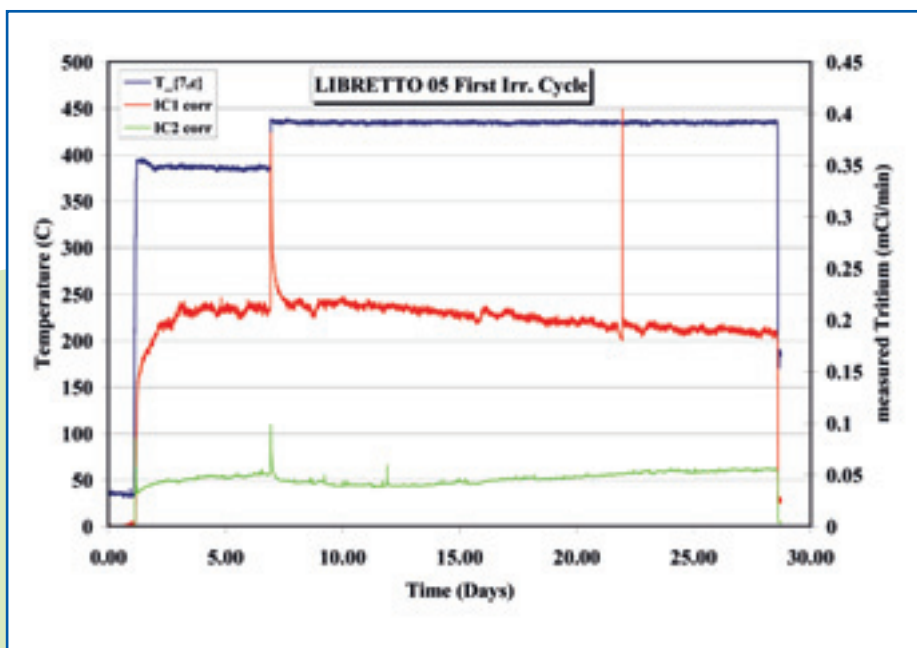
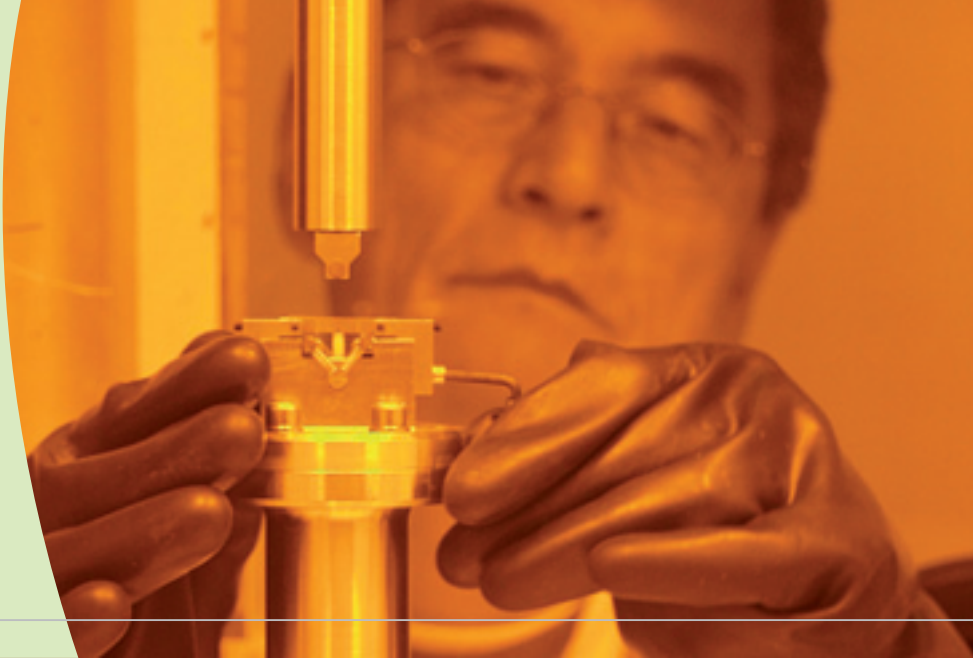

Figure 41 - Start-up of in-pile irradiation of LIBRETTO-5, with peak temperature of LiPb-alloy (blue), tritium signal in purge-gas (red) and permeation flow in secondary containment.

Partitioning and Transmutation Technologies



FUEL TRANSMUTATION

CONFIRM

Objective

Within the CONFIRM programme (Collaboration On Nitride Fuel Irradiation and Modelling), the properties of uranium-free nitride fuels are investigated. Uranium-free nitride fuels are under development as they possess, compared to oxide fuels, a better compatibility with the industrialised PUREX reprocessing process. Furthermore, they have the advantage of allowing a high linear power during irradiation. Nitride fuels can be applied in future generation (Generation IV) nuclear power reactors, specifically sodium cooled fast reactors, or in nuclear waste burners, so-called Accelerator Driven Systems (ADS). These fuels contribute to a more sustainable nuclear fuel cycle, due to their suitability for recycling, the option to increase irradiation power and burn-up and to optimise the use of fissile material, and the ability to eliminate high level nuclear waste in ADS systems. The lack of data on uranium-free nitrides, however, necessitates a significant R&D programme before nitrides can be qualified and validated. The CONFIRM programme is dedicated to theoretical and experimental studies to bridge this gap: to investigate nitride fuel characteristics and to test their performance under irradiation to high burn-ups.

Achievements

The CONFIRM irradiation was prepared in 2006 and consists of testing two plutonium fuel pins with 30% plutonium-nitride in a zirconium-nitride inert matrix; $(\text{Pu}_{0.3}\text{Zr}_{0.7})\text{N}$. In order to tune the neutron spectrum to typical conditions in fast reactors, the thermal part of the HFR spectrum is shielded in the irradiation. This is achieved by applying a hafnium shield, which effectively absorbs thermal neutrons. The CONFIRM fuel pellets, fabricated at the Paul Scherrer Institute in Switzerland, arrived in Petten in Spring 2007. After the arrival of the fuel pins, the irradiation sample holder was manufactured, assembled and all necessary procedures for quality control, safety approval and commissioning were followed subsequently. The CONFIRM irradiation started successfully on 25th November 2007 at 10:40 a.m. Thermocouples monitor the temperature of the pin cladding (approx. 500-550°C), which corresponds to realistic sodium temperatures (Figure 42). The CONFIRM irradiation will be completed by July 2008.

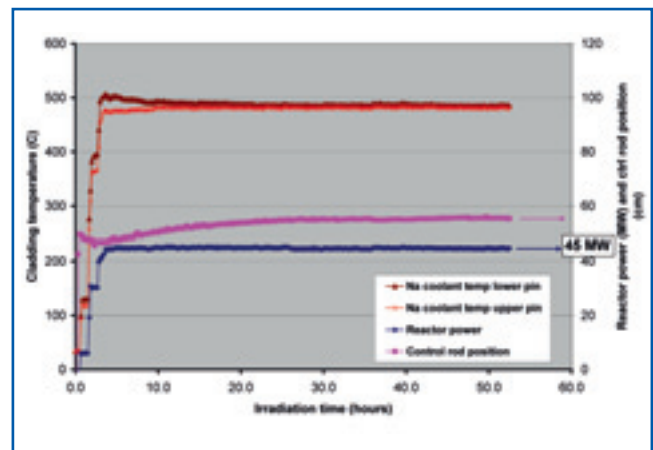

Figure 42 - Temperatures and reactor power at the start-up of CONFIRM on 25-11-2007 and first two days of irradiation



Figure 43 - Sodium filling of the CONFIRM irradiation



Figure 45 - Zoomed view of the HELIOS experiment during the assembly

HELIOS

Objective

Americium is one of the radioactive elements that contribute to a large part of the radiotoxicity of spent fuels. Transmutation by irradiation in nuclear reactors of long-lived nuclides like ^{241}Am is therefore, an option for the reduction of the mass and radiotoxicity of nuclear waste. The Helios experiment, as part of the FP6 EUROTRANS Integrated Project on Partitioning and Transmutation, deals with irradiation of U-free fuels containing americium. The main objective of the HELIOS irradiation is to study in-pile behaviour of U-free fuel targets, such as CerCer (Pu, Am, Zr) O_2 and $\text{Am}_2\text{Zr}_2\text{O}_7 + \text{MgO}$ or CerMet (Pu, Am) $\text{O}_2 + \text{Mo}$, in order to gain knowledge on the role of microstructure and temperature on gas release and on fuel swelling. During the irradiation of such kinds of fuel, a significant amount of helium is produced due to the nuclear transmutation of americium. The study of the gas release is of vital importance to allow better performance of the U-free fuels. Two different approaches are followed to reach early helium release:

1. Provide release paths by creating open porosity, i.e. release paths to the plenum gas. Therefore, in the HELIOS test matrix a composite target with a MgO matrix containing a network of open porosity has also been included.

2. Increase target temperature in order to promote the release of helium from the matrix. Americium or americium/plutonium zirconia based solid solutions along with CerMet targets have been included in the test matrix to study the effects of the temperature. The role of the plutonium in association with americium is to increase the temperature of the target at the beginning of irradiation.

Achievements 2007

Careful and more detailed analyses have led to the prediction of unacceptable distortions of the containment of the experiment (sample holder) due to unbalanced thermal displacement. The experiment had to be delayed due to the re-design of the sample holder. Nevertheless, some relevant milestones have been reached during 2007. The fuel has been produced at the JRC-ITU institute and at CEA. The fuel has been encapsulated in the 5 pins of 15-15 Ti steel and successfully transported to the HFR. Here the fuel has been radio-graphed. The conclusion of such NDT was that the condition of the pins and the fuel inside are good and in line with expectations. The new design will be finalized in March 2008. New nuclear and thermo-mechanical analyses will be performed in April-May 2008. The assembly of the experiment will be finished during September 2008 and the irradiation will start at the end of 2008.

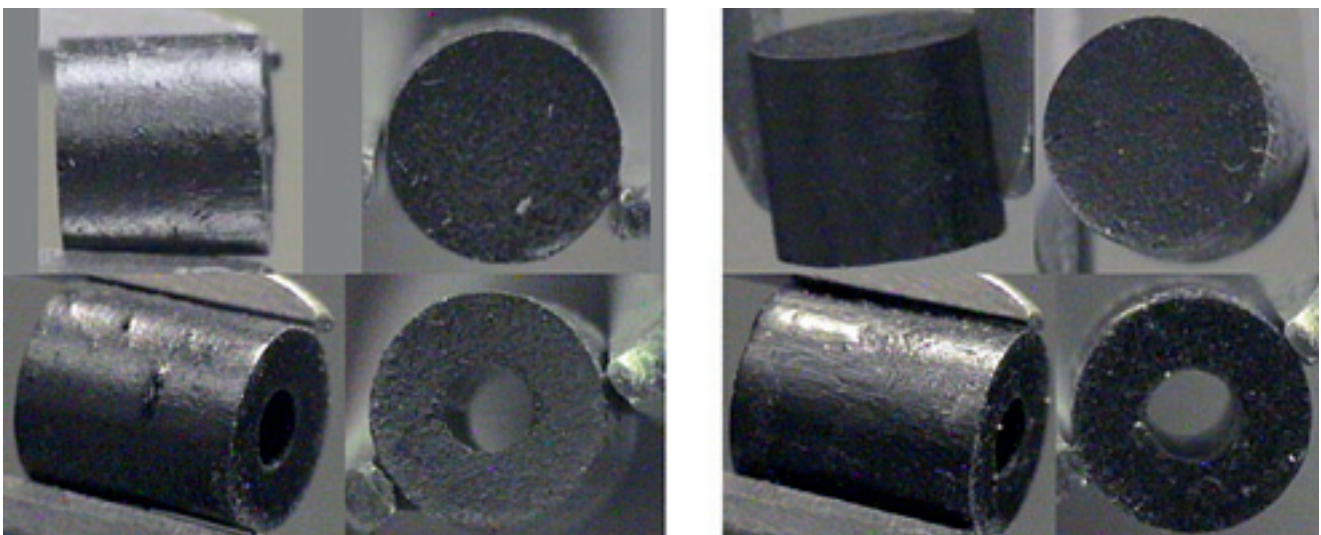

Figure 44 - HELIOS fuel pellets of pin 3, (Zr, Y, Am, Pu) O_2 (Note: Pin 3 is instrumented with a Thermocouple then contains annular pellets)

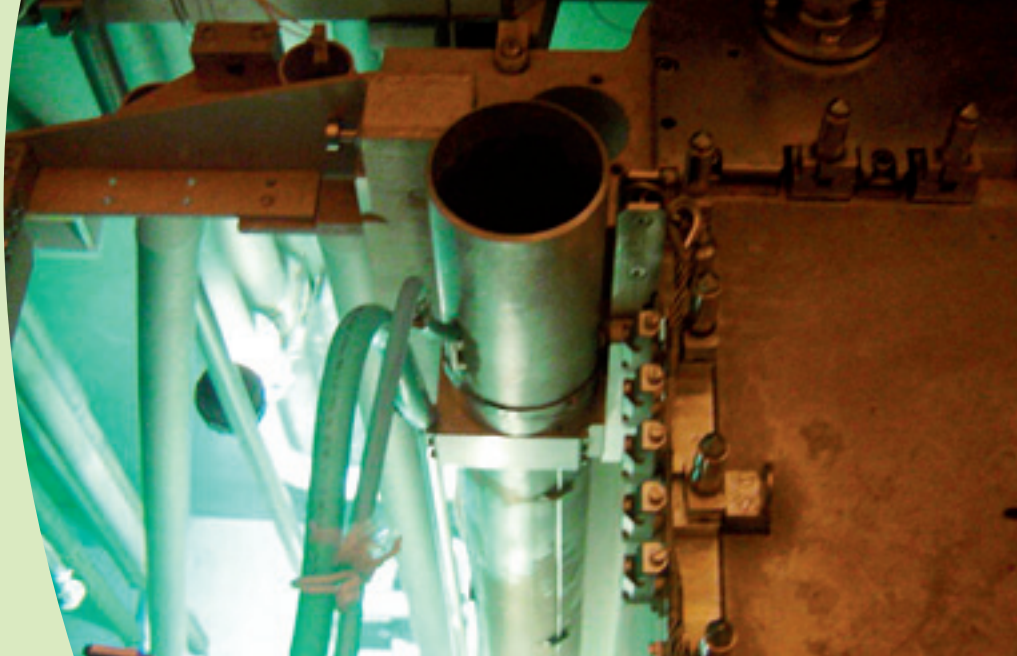

Figure 46 - SIFA in Pool Side Facility

TRABANT-02 / SMART

The remaining fuel pin in the TRABANT-02 experiment, named SMART, is composed of two separate fuel pins, one on top of the other, both containing 0.9 g/cm^3 of plutonium, incorporated into an yttria-stabilised zirconia phase, $(\text{Zr,Y,Pu})\text{O}_{2-x}$, with one composite fuel type mixed with stainless steel powder acting as the fuel matrix. The experiment has the aim to assess the irradiation behaviour of such fuels up to medium burn-up. The continuation of the SMART irradiation was further delayed due to technical reasons, but is now scheduled to re-start in early 2008.

ADS MATERIAL DEVELOPMENT

Objectives

In Europe, an experimental Accelerator Driven System (ADS) for the transmutation of actinides is under development. Liquid Lead Bismuth Eutectic (LBE) will be used as reactor coolant. Lead Bismuth has a low melting point (135°C), but has corrosive properties with structural materials and welds. In addition, transmutation of Bi to the highly radiotoxic ^{210}Po is a safety issue in the design of the ADS. Materials R&D is needed to test the corrosion behaviour of T91, 316L and weld specimens during irradiation in contact with LBE and to examine the deposition of ^{210}Po in the irradiation containers and on the specimens after irradiation.

Achievements in 2007

Three capsules for the IBIS irradiation have been filled at SCK with Lead Bismuth Eutectic. The licence for the experiment design and the post-irradiation testing has been given a positive advice by Reactor Safety Committee and permission to start has been approved by the NRG management. After a zero dpa test-run in the HFR, the experiment started in November. Two IBIS capsules have been irradiated in a low flux position in the HFR for two cycles at respectively 300 and 500°C , the desired temperatures for this experiment. The irradiation will continue into 2008 until a dose of 2 dpa is reached.

NEUTRON TRANSMUTATION DOPING OF SILICON

Silicon has three stable isotopes: ^{28}Si (92% abundance), ^{29}Si (5% abundance) and ^{30}Si (3% abundance). Neutron irradiation of silicon transmutes ^{30}Si into ^{31}Si , which decays (half-life 2.6 hours) to the stable isotope ^{31}P . This phosphorous doping decreases the electrical resistivity of the semiconductor silicon. Irradiating the silicon in a homogeneous flux causes a homogeneous phosphorous doping of the silicon. This neutron doped silicon has a higher quality than silicon ingots doped during the production of the ingots. Due to its high quality, neutron doped silicon is especially suitable for high power applications.

In 2007 the number of 6 inch silicon irradiations increased strongly, while the number of 4 inch silicon irradiations decreased.

List of Authors



Editorial Team

Editor Responsible: G. Gouwens-van Rijn

Revision: R. Moss, R. Hurst

Overall responsible: R. May

JRC Main Contributors

B. Acosta

E. D'Agata

M. Fütterer

S. Nievaart

R. May

R. Moss

C. Ohms

N. Taylor

O. Uca

Other JRC Contributors

J. Manten

D. McGarry

NRG Main Contributors

K. Bakker

K. Charlton

G.J.L.M. de Haas

A.I. van Heek

J.B.J.W. Hegeman

F.C. Klaassen

J.G. v.d. Laan

A.J. Magielsens

J.A. Vreeling

F.J. Wijtsma

E.J. de Widt

L.E. Zuurbier

The Editorial Team wishes to thank all other JRC and NRG staff who contributed to this report.

Address/Contact

European Commission – Joint Research Centre

Institute for Energy – High Flux Reactor Unit

P.O. Box 2

1755 ZG PETTEN, The Netherlands

Tel.: +31 (0)224 565151

Fax: +31 (0)224 565627

E-mail: gerda.gouwens@ec.europa.eu

Internet: <http://ie.jrc.ec.europa.eu>

A list of HFR scientific publications mentioned in this Annual Report can be obtained upon request to the contact person.

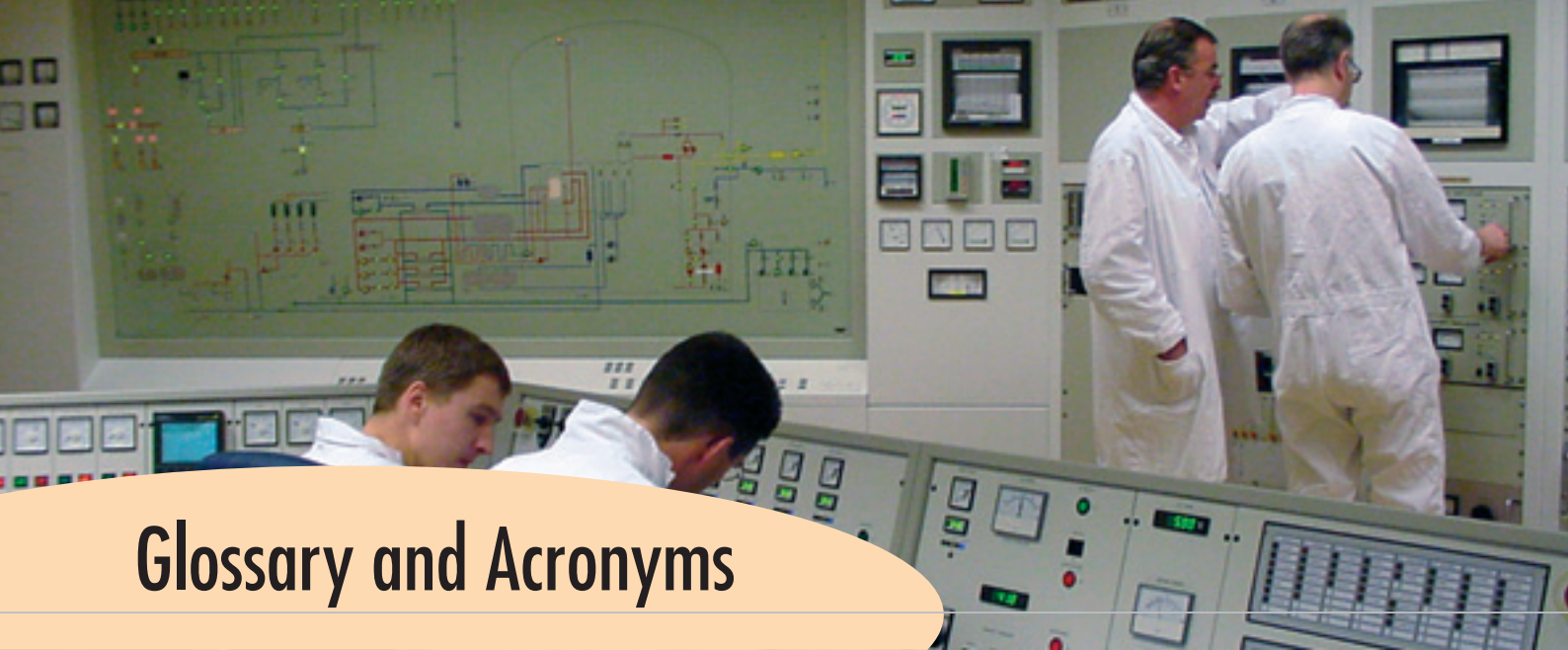

Glossary and Acronyms

ADS	Accelerator Driven Systems	LEU	Low Enriched Uranium
AMALIA	Assessment of Materials Ageing under the effect of Load and Irradiation-Assisted stress-corrosion cracking	LFRR	Low Flux Reactor
		LIBRETTO	Liquid Breeder Experiment with Tritium Transport Option
AMES	Ageing Materials Evaluation Studies	LYRA	Irradiation Facility for European Network for AMES
BNCT	Boron Neutron Capture Therapy	MCNP	Monte Carlo Neutron Photon
BPA	Borono-phenylalanine (Boron compound for BNCT)	MOX	Mixed Oxide
BSH	Borocaptate sodium (Boron compound for BNCT)	MYKONOS	Molybdenum Production for Mallinckrodt Diagnostica
BWR	Boiling Water Reactor	NET	Network on Neutron Techniques Standardisation for Structural Integrity
CEA	Commissariat à l'Energie Atomique	NESC	Network for Evaluating Structural Components
CONFIRM	Collaboration On Nitride Fuel Irradiation and Modelling	NDT	Non-Destructive Technology
COVERS	Coordinated action on WWER safety	NPP	Nuclear Power Plant
COVRA	Centrale Organisatie Voor Radioactief Afval	NRG	Nuclear Research and consultancy Group
DEMO	Demonstration Fusion Reactor	ODS	Oxide Dispersion Strengthened
DG	Directorate General	PBL	Peripheral Blood Lymphocytes
dpa	displacements per atom	PERFECT	Prediction of irradiation damage effects on reactor components
E&I(A)	Enlargement and Integration (Action)	PBMR	Pebble Bed Modular Reactor
EC	European Commission	PIE	Post Irradiation Examinations
ECN	Energieonderzoek Centrum Nederland	PISA	Phosphorus Influence on Steel Ageing
EORTC	European Organisation for Research and Treatment of Cancer	PLIM	Plant Life Management
ERA	European Research Area	PSF	Pool Side Facility
EU	European Union	PWR	Pressurized Water Reactor
EURATOM	European Atomic Energy Community	R&D	Research and Development
EUROTRANS	European Transmutation	RAFAM	Reduces Activation Ferritic Martensitic (steel)
EXOTIC	EXtraction Of Tritium In Ceramics	RAPHAEL	Reactor for Process Heat and Electricity
EXTREMAT	New Materials for Extreme Environments	RELEX	External Relations
FLUX	Fluence Rate	RPV	Reactor Pressure Vessel
FP or FWP	Framework programme	RTD	Research and Technological Development
FRAME	Fracture Mechanics Based Embrittlement Trend Curves for the Characterisation of Nuclear Pressure Vessel Materials	SAFELIFE	Safety of Aging Components in Nuclear Power Plants
GIF	Generation IV International Forum	SAFETY-INNO	Safety of Innovative Reactor Designs
HABOG	Interim storage centre for high level waste	SANS	Small Angle Neutron Scattering
HAW	High Active Waste	SCC	Stress Corrosion Cracking
HB	Horizontal Beam Tube	SIFA	Silicon FAcility
HCL	Hot Cell Laboratories	STROBO	Stress Relaxation of Bolt Materials
HELIOS	Helium in Oxide Structure	SUMO	In-Sodium Steel Mixed Specimens Irradiation
HEU	High Enriched Uranium	TBM	Test Blanket Modules
HFR	High Flux Reactor	TEM	Transmission Electron Microscope
HICU	High-fluence Irradiation of breeder Ceramics	TG	Task Group
HIDOBE	High Dose Beryllium Irradiation Rig	TN	Technology Network
HTR	High Temperature Reactor	TNO	Nederlandse Organisatie voor Toegepast Natuurwetenschappelijk Onderzoek (Netherlands Organization for Applied Scientific Research)
IAEA	International Atomic Energy Agency	TRABANT	TRAnsmutation and Burning of Actinides in a TRIOX
IASCC	Irradiation Assisted Stress Corrosion Cracking	TRIO	Irradiation device with three thimbles
IE	JRC Institute for Energy, Petten (NL)	TRIOX	TRIO modified for irradiation of MOX fuels
IEA	International Energy Agency	TRISO	Tristructural Isotropic
INPRO	International Project on innovative nuclear reactors and fuel cycles	TYCOMO	TYCO Molybdenum
IRMM	Institute for Reference Materials and Measurements	UNESCO	United Nations Educational Scientific and Cultural Organization
ISI	In-Service Inspection	VVER	Russian Pressurized Water Reactor
ISNCT	International Society of Neutron Capture Therapy	WWER	Water cooled, Water moderated Energy Reactor
ITER	International Thermonuclear Experimental Reactor		
ITU	Institute for TransUranium Elements, Karlsruhe		
JRC	Joint Research Centre		

European Commission

**EUR 23421 EN - DG JRC - Institute for Energy
Operation and Utilisation of the High Flux Reactor
Annual Report 2007**

Edited by: R. Moss, G. Gouwens - van Rijn, R. May

Luxembourg: Office for Official Publications of the European Communities

2007 - 36 pp. - 21 x 29.7 cm

Scientific and Technical Research Series

Abstract

The High Flux Reactor (HFR) at Petten is managed by the Institute for Energy (IE) of the EC - DG JRC and operated by NRG who are also licence holder and responsible for commercial activities.

The HFR operates at 45 MW and is of the tank-in-pool type, light water cooled and moderated. It is one of the most powerful multi-purpose materials testing reactors in the world and one of the world leaders in target irradiation for the production of medical radioisotopes.

The mission of the JRC is to provide customer-driven scientific and technical support for the conception, development, implementation and monitoring of EU policies. As a service of the European Commission, the JRC functions as a reference centre of science and technology for the Union. Close to the policy-making process, it serves the common interest of the Member States, while being independent of special interests, whether private or national.

