

COMMISSION OF THE EUROPEAN COMMUNITIES

COM(80) 849 final

Brussels, 16 December 1980

Proposal for a
COUNCIL DIRECTIVE

on the approximation of the laws of the Member States relating to the installation, location, operation and identification of controls, tell-tales and indicators on wheeled agricultural or forestry tractors

(submitted to the Council by the Commission)

COM(80) 849 final

EXPLANATORY MEMORANDUM

I. ECONOMIC INTEREST OF THE SECTOR

Since the Second World War the agricultural tractor industry has undergone a dynamic growth which is linked to the mechanisation of modern farming. Indeed the tractor has played a privileged part in this mechanisation process: thus in Europe, half the turnover of the agricultural machinery industry is due to tractor sales.

The Community agricultural tractor industry at present produces about 300 000 tractors. It is based on an internal market which represents the largest world outlet for tractors, ahead of North America and Japan. The LDC market, in spite of its great needs, remains of limited importance due to the weakness in the solvency of the demand.

The European producers have taken into account the internal market dimension in the implementation of their development strategy. The production which is concentrated in the hands of a few big multinational firms has a tendency to be shared out on a regional, not to say worldwide basis. This international redistribution of the production sites leads, as in the automobile industry, to the development of trade in components. The redeployment does not, however, affect the LDCs towards which the movement of the production activity remains marginal.

The internationalisation of the production activity is, in any case, at the origin of the intensified trade which could be noted in the past few years. Thus inside the Community, trade tends to grow more rapidly than production. This evolution essentially affects intra-Community trade. Community trade with third countries, on the other hand marks a decrease in absolute value linked to the compression of activity which can be noted throughout the world markets.

This recent evolution can be characterized by the stagnation of the demand, a fact which is not peculiar to Europe and which can be explained by the progressive saturation of demand for an initial fitting-out. The mechanization process in agriculture is almost completed.

Several conjunctural factors accentuate this tendency: stagnation of farmers' income contrasting with the rise in industrial costs, climatic variations

affecting certain client countries (L.D.Cs in particular). The tractor industry is thus moving towards the satisfaction of demands for the renewal of equipment.

In spite of the progressive stabilisation of the number of tractors sold, the market should nevertheless register a rise in value in the coming years. The greater sophistication of the vehicles as well as their greater power contribute towards raising the unit value. On the other hand, the perspectives created by the industrial applications of microelectronics and the adjustments made necessary by the energy constraints will no doubt lead to the development of a qualitatively new demand.

In such a context of rapid market evolution, the pressure of competition should become greater, taking into account the growth of certain producer countries, such as Japan, whose market penetration is as yet limited in Europe but whose development objectives lead to fears of an increase in its share of the world market.

This exacerbation of international competition will lead producers to put particular weight on maintaining their competitive position. The Community industry has at its disposal an essential trump card to play in the present situation: the importance of its internal market which, in all probability, should keep its predominant position.

The elimination of technical barriers to trade in this field will thus efficiently contribute to the strengthening of the Community market and therefore to the European industry's competitive capacity. That is why the Commission attaches particular importance to this directive on the harmonisation of national legislation relating to agricultural tractors.

The Commission immediately put the necessary work in hand. In accordance with the method that had been employed for motor vehicles, it proposed to the Council a Directive relating to the type-approval of wheeled agricultural or forestry tractors (1) which was adopted in 1974. That Directive made provision for the transmission to the Council of numerous proposals relating to the various technical specifications for tractors. The intention was for the progressive harmonization of the Community specifications to be achieved as and when these proposals were adopted. So far, 20 separate directives have been adopted. The Commission is determined to continue its work, and, if the Council continues to adopt the corresponding directives at the same rate as

(1) OJ L 84 of 28.3.1974.

heretofore, the complete harmonization of specifications for the tractors referred to in the Directive on type-approval will be achieved in the near future. This proposal is part of the last set of proposals which remains to be placed before the Council for the EEC type-approval system to be completed.

II. GENERAL

Like the Directives already adopted in this field, this proposal fits into the pattern of the type-approval procedure at Community level which was the subject of Council Directive 74/150/EEC of 4 March 1974 (1).

It concerns the proposals from the Commission relating to the installation, location, operation and identification of controls, telltales and indicators on wheeled agricultural or forestry tractors. These proposals lay down construction requirements so that the driver of the tractor can operate his tractor in safety and without excessive fatigue (controls) and can easily identify the controls, telltales and indicators. The symbols to be used are presented as an Annex.

When preparing this proposal, the Commission used as a basis the work carried out along the same lines in the motor-vehicle sector, in respect of which a similar Directive was adopted in 1978 (Directive 78/316/EEC, OJ L 81 of 28.02.1978) together with certain technical specifications adopted by the International Organization for Standardization (ISO).

Finally, it should be stressed that the aim of this approximation of national laws is intended not only to remove barriers to trade, but also to increase safety and, in respect of the location of and symbols to be used for the controls, to surmount the problem associated with indications in the various languages.

When preparing this proposal, the Commission took ample account of the opinions of governmental experts and experts from the industries concerned who were members of the Working Party on Agricultural Tractors and Machinery. Nonetheless, as regards the requirements relating to the clutch and power-take-off actuator controls, certain experts expressed reservations, since, in their opinion, it would be better to await completion of the proposal

(1) OJ L 84 of 28.3.1974, p. 10.

for a Directive on power-take-off. The Commission nonetheless considered that the provisions proposed were a good compromise and that it was better not to delay putting forward this proposal.

III. REMARKS ON THE ARTICLES

The Directive applies to wheeled agricultural or forestry tractors with a maximum design speed of between 6 and 25 km/h (Article 1).

Article 2 incorporates into the EEC type-approval procedure the requirements relating to the installation, location, operation and identification of controls, telltales and indicators and the provisions making it possible to guarantee that the tractors are used in accordance with the provisions of the Directive in certain new Member States which have no national type-approval procedure at present.

Article 3 lays down the procedure for adaptation of the Directive to technical progress, this procedure being set out in Article 13 of the Council Directive of 4 March 1974 relating to the type-approval of field agricultural or forestry tractors.

Article 4 lays down that the Member States shall have a period of 18 months to adjust to the Directive (Article 4(1)).

Finally, the Commission must be informed within a reasonable period of the draft provisions drawn up by the Member States in the field covered by the Directive, so that it will be able to prepare any comments that might be necessary in respect of this draft (Article 4(2)).

IV. CONSULTATION OF THE EUROPEAN PARLIAMENT AND THE ECONOMIC AND SOCIAL COMMITTEE

The opinions of these two bodies are necessary in accordance with the provisions of the second paragraph of Article 100 of the Treaty establishing the European Economic Community.

V. IMPLEMENTATION OF THIS DIRECTIVE BY THE MEMBER STATES

The Commission does not foresee any difficulties for the implementation of this Directive by the Member States.

Indeed in the field of wheeled agricultural or forestry tractors more than twenty Directives have already been adopted since 1974.

The Member States are thus very much familiarized with this type of text and have at their disposal the competent departments for the implementation of such texts.

THE COUNCIL OF THE EUROPEAN COMMUNITIES,

Having regard to the Treaty establishing the European Economic Community,
and in particular Article 100 thereof;

Having regard to the proposal from the Commission;

Having regard to the opinion of the European Parliament;

Having regard to the opinion of the Economic and Social Committee;

Whereas the technical requirements with which wheeled agricultural or forestry tractors must comply under national laws relate, inter alia, to the installation, location, operation and identification of controls, telltales and indicators;

Whereas such requirements differ from one Member State to another; whereas it is thus necessary for the same requirements to be adopted by all the Member States, either in addition to or instead of their present regulations, in order in particular to allow the implementation, for each type of vehicle, of the EEC type-approval procedure which is the subject of Council Directive 74/150/EEC of 4 March 1974 on the approximation of the laws of the Member States relating to the type-approval of field agricultural or forestry tractors (1);

Whereas it is advisable to formulate the technical requirements so that their objective is the same as that of the corresponding work performed in the motor-vehicle sector and of certain technical requirements adopted by the International Organization for Standardization (ISO); whereas the harmonization of these requirements is an obvious safety factor and, where the location of the controls and the symbols used for them are concerned, makes it possible to surmount the problem associated with indications in the various languages;

Whereas the approximation of national laws concerning wheeled agricultural or forestry tractors comprises recognition by each Member State of checks carried out by other Member States on the basis of common requirements,

HAS ADOPTED THIS DIRECTIVE :

(1) OJ No L 84 of 28.3.1974, p. 10.

Article 1

1. "Agricultural or forestry tractors" means any motor vehicle fitted with wheels or endless tracks and having at least two axles, the main function of which lies in its tractive power and which is specially designed to tow, push, carry or power certain tools, machinery or trailers intended for agricultural or forestry use. It may be equipped to carry a load or passengers.
2. This Directive shall apply only to tractors as defined in paragraph 1 which are fitted with pneumatic tyres and which have two axles and a maximum design speed of between 6 and 25 kilometres per hour.

Article 2

No Member State may refuse to grant EEC type-approval or national type-approval of a tractor or refuse or prohibit the sale, registration, entry into service or use of a tractor on grounds relating to the installation, location, operation or identification of controls, telltales and indicators, if these satisfy the requirements set out in Annexes I, II, III and IV.

Article 3

The amendments necessary for adapting the requirements of the Annexes to technical progress shall be adopted in accordance with the procedure laid down in Article 13 of Directive 74/150/EEC.

Article 4

1. Member States shall bring into force the laws, regulations and administrative provisions necessary in order to comply with this Directive not later than 30 September 1983. They shall forthwith inform the Commission thereof.
2. Member States shall ensure that the texts of the main provisions of national law which they adopt in the field covered by this Directive are communicated to the Commission.

Article 5

This Directive is addressed to the Member States.

LIST OF ANNEXES

- ANNEX I Definitions, application for EEC type-approval, EEC type-approval
- ANNEX II Technical requirements - general and special requirements
- ANNEX III Symbols
- ANNEX IV Construction of the basic model for the symbols to be used
- ANNEX V Annex to the EEC type-approval certificate for a tractor type with regard to the location, operation and identification of controls, tell-tales and indicators.

ANNEX 1

DEFINITIONS, APPLICATION FOR EEC TYPE-APPROVAL, EEC TYPE-APPROVAL

1. DEFINITIONS

1.1. Tractor type

"Tractor type as regards the installation, location, operation and identification of controls, telltales and indicators" means tractors which do not differ as regards those internal fittings which may affect the installation, location, operation and identification of controls, telltales and indicators.

1.2. Control

"Control" means that part of a device which enables the driver to bring about a change in the state or functioning of the tractor.

1.3. Switch

"Switch" means a device by which the supply to an electrical circuit can be cut off or reconnected.

1.4. On/off switch

"On/off switch" means a device by which the electricity supply between two different circuits can be changed, without the possibility of a cut-off between the two positions.

1.5. Combined on/off-selector switch

Combined on/off-selector switch means a multi-function device which on first being actuated or put into position operates as an/off switch and on each of the subsequent occasions when it actuated or put into position operates as a selector switch.

1.6. Telltale

"Telltale" means an optical and/or acoustic signal indicating the actuation of a device, the correct or defective functioning or condition of the device or its failure to function.

1.7. Operating telltale

"Operating telltale" means a telltale which indicates whether an actuated device is functioning correctly or not.

1.8. Actuating telltale

"Actuating telltale" means a telltale which indicates that a device has been actuated but does not indicate whether it is functioning correctly or not.

1.9. Indicator

"Indicator" means a device which provides information on the functioning or situation of a system or part of a system, e.g., a fluid level.

1.10. Symbol

"Symbol" means a drawing by which a control, telltale or indicator can be identified.

1.11. Driver

"Driver" means the person sitting in the driver's seat in the normal attitude for driving the tractor.

1.12. Forward of the driver

"Forward of the driver" means that part of the tractor situated forward of a plane perpendicular to the longitudinal median plane of the tractor and situated 300 mm forward of the seat reference point, as defined in Directive 78/764/EEC on the approximation of the laws of the Member States relating to the driver's seat on wheeled agricultural or forestry tractors, when the seat is adjusted to the mid-point of its travel in the longitudinal direction.

2. APPLICATION FOR EEC TYPE-APPROVAL

2.1. The application for type-approval of a tractor type with regard to the installation, location, operation and identification of controls, telltales and indicators must be submitted by the tractor manufacturer or by his authorized representative.

2.2. It must be accompanied by :

2.2.1. drawings in triplicate, to an appropriate and sufficiently detailed scale, of the tractor parts covered by the provisions of this Directive and of the symbols shown in Annex III.

2.3. a tractor representative of the type to be approved or the tractor part(s) regarded as essential for the execution of the check laid down in this Directive must be submitted to the technical service responsible for type-approval.

3. EEC TYPE-APPROVAL

3.1. A form conforming to the model in Annex V should be attached to the EEC type-approval certificate.

ANNEX II

TECHNICAL REQUIREMENTS

1. GENERAL REQUIREMENTS

- 1.1. The controls must be readily accessible : they must not constitute a danger and must be capable of being actuated without risk. The controls must be so designed and positioned as to preclude any inadvertent switching operation or any unintentional triggering of a movement or any other operation. This condition shall be considered as fulfilled if, for example :
 - the control lever can be mechanically locked,
 - the control system can be hydraulically locked,
 - the steering system can be electromechanically locked, and
 - the controls are protected by a cover.
- 1.2. Symbols conforming to those shown in Annex III must be used for the purposes of identifying controls, telltales and indicators.
- 1.3. Symbols other than those shown in item 2 of Annex II and in Annex III may be used for other purposes, provided that there is no danger of confusion with those shown in these Annexes.
- 1.4. Symbols are deemed to conform if the proportionality of the dimensions shown in Annex IV is respected.
- 1.5. A driver with normal vision must be capable of identifying the symbols.
- 1.6. The symbols must appear on or in the immediate proximity of controls, telltales and indicators.
- 1.7. The symbols must stand out clearly against the background, being of a colour that contrasts with it.
- 1.8. The colours used for telltales must be those prescribed in item 2.2. below.
- 1.9. The installation, location, operation and identification of controls, telltales and indicators must satisfy the particular requirements set out in item 2 below.

2. PARTICULAR REQUIREMENTS

2.1. CONTROLS

2.1.1. Starter control

2.1.1.1. Installation : mandatory.

2.1.1.2. Location : within easy reach of the driver.

2.1.1.3. Operation :

2.1.1.3.1. It must not be possible to start the engine :

- if the rotation of the engine is liable to be transmitted to the tractor's driving wheels;
- by access to the solenoid terminals.

2.1.1.3.2. Furthermore, if the starter control is of the starter/ignition switch (spark ignition) type or starter switch (compression ignition) type, the following method of operation must be complied with :

2.1.1.3.2.1. starter/ignition switch (spark ignition) : the switch must be turned clockwise until the ignition position reached. By continuing to turn in the same direction, it must be possible to actuate the starter. If auxiliary positions are provided, these must be situated between the "stop" position and the ignition position. If a rotary switch is not provided, the control must be moved towards the ignition position.

2.1.1.3.2.2. starter switch (compression ignition) : the control must move towards the starter position. If a rotary switch is provided, it must be turned clockwise in order to start the engine. If an engine heater circuit is provided, its control must be situated immediately before the starter position, or it must be possible to engage the operating position by turning it clockwise.

2.1.1.4. Identification : optional.

2.1.2. Engine speed control

2.1.2.1. Installation: mandatory, either foot-operated, hand-operated or foot and hand-operated.

2.1.2.2. Location.

2.1.2.2.1. Foot-operated: within easy reach of the driver's right feet and to the right of or behind the brake pedal(s).

2.1.2.2.2. Hand-operated: to the right and within easy reach of the driver.

2.1.2.2.3. Foot- and hand-operated: the provisions of items 2.1.2.2.1. and 2.1.2.2.2. are applicable.

2.1.2.3. Operation

2.1.2.3.1. Foot-operated : movement of the control forward and/or downwards must have the effect of increasing the engine speed.

2.1.2.3.2. Hand-operated : the control must be moved forward or upwards in order to increase the engine speed.

2.1.2.4. identification : mandatory if hand-operated
optional if foot-operated.

2.1.3. Engine shut-off control

2.1.3.1. Spark ignition engine

2.1.3.1.1. Installation : mandatory

2.1.3.1.2. Location : within easy reach of the driver.

2.1.3.1.3. Operation : the starter/ignition switch must be turned anti-clockwise towards the "stop" position (open circuit) and must automatically remain in that position without the application of a sustained manual effort. If the starter/ignition switch is not of the rotary type, the control must move towards the "stop" position and must automatically remain in that position without the application of a sustained manual effort.

2.1.3.1.4. Identification : mandatory.

2.1.3.2. Compression ignition engine

2.1.3.2.1. Installation : mandatory.

2.1.3.2.2. Location : within easy reach of the driver.

2.1.3.2.3. Operation : the control must move towards the "stop" position and must automatically remain in that position without the application of a sustained manual effort.

2.1.3.2.4. Identification : mandatory. The stop control shall be of a colour which contrasts with its background and that of other controls. If the control is in the form of a button, it must be coloured red and contrast with the background.

2.1.4. Steering control

2.1.4.1. Installation : mandatory.

2.1.4.2. Location : within easy reach and forward of the driver.

2.1.4.3. Operation : when a steering-wheel is provided, clockwise rotation must cause the vehicle to bear right and anticlockwise rotation must cause the vehicle to bear left.

When two levers are provided for steering purposes, the right-hand lever must be drawn back in order to turn right. For a left turn, the left-hand lever must be drawn back.

When a single lever is provided for steering purposes, lateral movement of the lever to the right must cause the vehicle to bear right and lateral movement of the lever to the left must cause the vehicle to bear left.

2.1.4.4. Identification : no requirements.

2.1.5. Service brake control

2.1.5.1. Installation: mandatory, either foot-operated or hand-operated.

2.1.5.2. Location :

2.1.5.2.1. Foot-operated: within easy reach of the driver's right foot.

2.1.5.2.2. Hand-operated: within easy reach of the driver.

2.1.5.3. Operation :

2.1.5.3.1. Foot-operated: the brake is applied by moving the pedal forward and/or downwards.

2.1.5.3.2. Hand-operated: the brake is applied by a drawing movement.

2.1.5.4. Identification: no requirements.

2.1.6. Parking brake control

2.1.6.1. Installation: mandatory.

2.1.6.2. Location: within easy reach of the driver.

2.1.6.3. Operation :

2.1.6.3.1. Hand-operated : a device must be provided which will secure the brake(s) when applied and prevent it(them) from being accidentally removed.

2.1.6.3.2. Foot-operated : the brake is applied by pressing the pedal. The device must prevent the brake(s) from being accidentally removed.

2.1.6.4. Identification : optional.

2.1.7. Clutch and transmission control

2.1.7.1. Installation : optional in the case of an engine with an automatic gear-box, mandatory in other cases.

2.1.7.2. Location :

2.1.7.2.1. Foot-operated : within easy reach of the driver's left foot.

2.1.7.2.2. Hand-operated : within easy reach of the driver.

2.1.7.3. Operation :

2.1.7.3.1. Foot-operated : the drive mechanism is disengaged by moving the pedal forward and/or downwards.

2.1.7.3.2. Hand-operated : the drive mechanism is disengaged by moving the lever backwards and/or downwards.

2.1.7.4. Identification : no requirements.

2.1.8. Tractor speed and direction-of-travel control (in the case of automatic transmission)

2.1.8.1. Installation : mandatory.

2.1.8.2. Location :

2.1.8.2.1. Foot-operated : within easy reach of the driver's right foot.

2.1.8.2.2. Hand-operated : within easy reach of the driver.

2.1.8.3. Operation :

2.1.8.3.1. Foot-operated : after the fashion of a swivelling pedal under the driver's foot, forward or downward movement of the front part of the pedal must cause the tractor to move in forward gear and to accelerate in that direction; backward and/or downward movement of the rear part of the pedal must cause the tractor to go into reserve and accelerate in that direction. When the pedal is not in use, it must return to neutral and remain in that position.

- 2.1.8.3.2. Hand-operated : from the neutral position the lever is moved forward to accelerate the tractor in forward gear and backwards to put the tractor in reverse. A positive "neutral position" must be provided such that the control must make a secondary movement before passing from forward gear to reverse gear.
- 2.1.8.4. Identification : optional.
- 2.1.9. Differential lock control
 - 2.1.9.1. Installation : optional.
 - 2.1.9.2. Location :
 - 2.1.9.2.1. Hand-operated : within easy reach of the driver.
 - 2.1.9.2.2. Foot-operated : within easy reach of the driver.
 - 2.1.9.3. Operation : if the control is mechanical, forward and/or downward movement of the control must engage the differential lock. If the control is hand-operated, a sideways movement of the control is also permitted.
 - 2.1.9.4. Identification : mandatory if the control is fitted.
The differential lock position must be clearly indicated.
- 2.1.10. Power take-off clutch control
 - 2.1.10.1. Installation : mandatory, either foot-operated or hand-operated, if there is a power take-off.
 - 2.1.10.2. Location :
 - 2.1.10.2.1. Foot-operated : within easy reach of the driver's left foot.
 - 2.1.10.2.2. Hand-operated : within easy reach of the driver.

- 2.1.10.3. Operation :
- 2.1.10.3.1. Foot-operated: in order to declutch, the pedal is moved forward and/or downwards.
- 2.1.10.3.2. Hand-operated: in order to declutch, the control is moved downwards and/or backwards.
- 2.1.10.4. Identification: mandatory if the control is fitted. The declutched position must be clearly indicated.

- 2.1.11. Power-take-off actuator and/or rotational-speed selector
- 2.1.11.1. Installation: mandatory when there is a power take-off.
- 2.1.11.2. Location: within easy reach of the driver.
- 2.1.11.3. Operation: if the power take-off is of the two-speed type, the design and construction of the speed selector shall be such as to preclude any unintentional selection of the higher speed. This safety measure must be effective whenever a speed is selected.
- 2.1.11.4. Identification: mandatory if the actuator/selector is fitted. The rotational speed selected shall be clearly indicated.

- 2.1.12. Lift mechanism(s) control
- 2.1.12.1. Installation : optional.
- 2.1.12.2. Location :
- 2.1.12.2.1. Hand-operated : within easy reach of the driver's hand. In the case of the three-point rear lifting mechanism, the control must be within easy reach of the driver's right hand.
- 2.1.12.2.2. Foot-operated : within easy reach of the driver's foot. In the case of the three-point rear lifting mechanism, the control must be within easy reach of the driver's right foot.

2.1.12.3. Operation :

2.1.12.3.1. Hand-operated : the control must be moved upwards and/or backwards when lifting and downwards and/or forward when lowering.

2.1.12.3.2. Foot-operated : downward movement of the front part of the pedal in order to lower and downward movement of the rear part in order to lift.

2.1.12.3.3. A system must be provided for the locking of the control while the tractor is in motion. If a hydraulic lift device has to be held in the raised position, a locking device for the hydraulic control lever must be provided so as to prevent inadvertent movement.

2.1.12.4. Identification : mandatory if the control is fitted.

2.1.13. Device(s) for remote control of external services

2.1.13.1. Installation: optional.

2.1.13.2. Location: within easy reach of the driver.

2.1.13.3. Operation: no requirements.

2.1.13.4. Identification: mandatory/if there is/are a selector/selectors. The selector(s) must clearly indicate the engaged or disengaged position.

2.1.14. Dipped headlamps switch

2.1.14.1. Installation: mandatory.

2.1.14.2. Location: within easy reach and forward of the driver.

2.1.14.3. Operation: no requirements.

2.1.14.4. Identification: mandatory.

- 2.1.15. On/off-selector switch for direction-indicator lights
- 2.1.15.1. Installation: mandatory.
- 2.1.15.2. Location: within easy reach and forward of the driver.
- 2.1.15.3. Operation: movement of the switch in a given direction must actuate the direction-indicator lights on the corresponding side of the tractor.
- 2.1.15.4. Identification: optional.
- 2.1.16. Hazard-warning-light switch
- 2.1.16.1. Installation: mandatory.
- 2.1.16.2. Location: within easy reach and forward of the driver.
- 2.1.16.3. Operation : no requirements.
- 2.1.16.4. Identification : mandatory.
- 2.1.17. Switch for side lights, rear lights and rear-number-plate lighting device
- 2.1.17.1. Installation : mandatory.
- 2.1.17.2. Location : within easy reach and forward of the driver.
- 2.1.17.3. Operation : no requirements.
- 2.1.17.4. Identification : mandatory.
- 2.1.17.a. Front position (side) lamp control
- 2.1.17.a.1. Installation : mandatory.
- 2.1.17.a.2. Location : within easy reach and forward of the driver.
- 2.1.17.a.3. Operation : no requirements.
- 2.1.17.a.4. Identification : mandatory.
- 2.1.18. Main-beam headlamps switch
- 2.1.18.1. Installation : mandatory if main-beam headlamps are fitted.
- 2.1.18.2. Location : within easy reach and forward of the driver. May be combined with the dipped-beam switch.

- 2.1.18.3. Operation : no requirements.
- 2.1.18.4. Identification : mandatory if a switch is fitted.
- 2.1.19. Front fog lamps switch
- 2.1.19.1. Installation : mandatory if front fog lamps are fitted.
- 2.1.19.2. Location : within easy reach and forward of the driver.
- 2.1.19.3. Operation : no requirements.
- 2.1.19.4. Identification : mandatory if a switch is fitted.
- 2.1.20 Reversing light(s) control
- 2.1.20.1. Installation : mandatory if reversing light(s) fitted. (see 2.1.20.3.)
- 2.1.20.2. Location : see 2.1.20.3.
- 2.1.20.3. Operation : It must come on only when the reversing control is engaged and when the engine starting or shut-off control is in a position such that the engine can run.
It must be incapable of coming on or remaining on if one of the above conditions is not met.
- 2.1.20.4. Identification : no requirements.
- 2.1.21. Stop lights control
- 2.1.21.1. Installation : mandatory if stop lights are fitted.
- 2.1.21.2. Location : combined with the service brake control.
- 2.1.21.3. Operation : engagement of the service brake must actuate the stop lights.
- 2.1.21.4. Identification : no requirements.

2.1.22. Rear fog lamp(s) switch

- 2.1.22.1. Installation : mandatory if rear fog lamp(s) fitted.
- 2.1.22.2. Location : within easy reach and forward of the driver.
- 2.1.22.3. Operation : no requirements.
- 2.1.22.4. Identification : mandatory if a switch is fitted.

2.1.23. On/off-selector switch for parking light(s)

- 2.1.23.1. Installation : mandatory if parking light(s) fitted.
- 2.1.23.2. Location : within easy reach and forward of the driver.
- 2.1.23.3. Operation : movement of the control in a given direction must actuate the parking light(s) on the corresponding side of the tractor.
- 2.1.23.4. Identification : mandatory if the control is fitted.

2.1.24. Outline marker lights switch

- 2.1.24.1. Installation : mandatory if outline marker lights are fitted.
- 2.1.24.2. Location : within easy reach and forward of the driver.
- 2.1.24.3. Operation : switching-on of the side and rear lights must actuate the outline marker lights.
- 2.1.24.4. Identification : mandatory if a switch is fitted and combined with that of the side rear lights and of the rear-number-plate lighting device.

2.1.25 Working light switch

- 2.1.25.1. Installation : mandatory if working light is fitted.
- 2.1.25.2. Location : no requirements.
- 2.1.25.3. Operation : no requirements.
- 2.1.25.4. Identification : mandatory, if the switch is not fitted on the light.

2.1.26. Windscreen wiper switch

- 2.1.26.1. Installation : mandatory, if windscreen fitted.
- 2.1.26.2. Location : within easy reach and forward of the driver.
- 2.1.26.3. Operation : no requirements.
- 2.1.26.4. Identification : mandatory, if the switch is not fitted on the windscreen wiper.

2.1.27. Audible warning device control

- 2.1.27.1. Installation : mandatory.
- 2.1.27.2. Location : within easy reach and forward of the driver.
- 2.1.27.3. Operation : actuation by sustained pressure must operate the control.
- 2.1.27.4. Identification : mandatory.

2.2. TELLTALES

2.2.1. Parking brake telltale (actuating telltale)

- 2.2.1.1. Installation : optional.
- 2.2.1.2. Location : within the driver's field of vision.

- 2.2.1.3. Operation : appearance of a red light which comes on when the ignition switch is in the ignition position and which serves as a reminder that the braking device control is engaged or not fully released.
- 2.2.1.4. Identification : mandatory if a telltale is fitted.
- 2.2.2. Driver-operated differential lock telltale (actuating telltale)
 - 2.2.2.1. Installation : optional in the case of a single differential lock, mandatory in the case of several differential locks.
 - 2.2.2.2. Installation : within the driver's field of vision.
 - 2.2.2.3. Operation : appearance of a red light which comes on when the switch is in the position where the engine may be started and which services as a reminder that the differential lock control is engaged. If the tractor has several differentials, the respective telltales must clearly indicate which differential(s) is/are locked.
 - 2.2.2.4. Identification : mandatory if a telltale is fitted.
- 2.2.3. Power take-off and/or rotational speed selector telltale (actuating telltale)
 - 2.2.3.1. Installation : optional.
 - 2.2.3.2. Location : within the driver's field of vision.
 - 2.2.3.3. Operation : appearance of an automatic yellow light when the power take-off is engaged.
 - 2.2.3.4. Identification : mandatory if telltale is fitted.

2.2.4. Dipped-headlamps telltale (actuating telltale)

- 2.2.4.1. Installation: optional.
- 2.2.4.2. Location: within the driver's field of vision.
- 2.2.4.3. Operation: appearance of a green light when the dipped headlamps are switched on.
- 2.2.4.4. Identification : optional.

2.2.5. Direction indicator lights telltale (operating telltale)

- 2.2.5.1. Installation: mandatory if the direction-indicator lights are not directly within the driver's field of vision.
- 2.2.5.2. Location: within the driver's field of vision.
- 2.2.5.3. Operation : it may be optical, accoustic or both. If it is optical, it must be a flashing green light which goes out or remains on without flashing or exhibits a marked change of frequency in the event of faulty operation of any one of the direction indicator lights. If it is solely accoustic, it must be clearly audible and exhibit a marked change of frequency under the conditions given above for the optical telltale.

When a tractor is equipped to pull a trailer, it must be fitted with a special optical operating telltale for the trailer's direction indicator lights unless the tractor telltale makes it possible to detect a failure in any one of the director indicator lights on the tractor and trailer.
- 2.2.5.4. Identification : mandatory if a telltale is fitted.

2.2.6. Hazard-warning-light telltale (actuating telltale)

2.2.6.1. Installation: mandatory if the synchronous operation of all the direction-indicator lights is not visible to the driver.

2.2.6.2. Location: within the driver's field of vision.

2.2.6.3. Operation : as soon as the hazard warning signal is switched on, an intermittant red light must appear on the switch and the direction indicator telltale symbols must flash simultaneously.

2.2.6.4. Identification : mandatory if a telltale is fitted.

2.2.7. Side and rear lights telltale (actuating telltale)

2.2.7.1. Installation: mandatory, but not required if the fascia lighting device can only be switched on at the same time as the side and rear lights.

2.2.7.2. Location: within the driver's field of vision.

2.2.7.3. Operation: appearance of a green light when the side and rear lights are switched on.

2.2.7.4. Identification: mandatory if a telltale is fitted.

2.2.8. Rear-number-plate lighting device telltale (actuating telltale)

2.2.8.1. Installation: optional. If fitted, must be combined with the side and rear lights telltale.

2.2.8.2. Location: within the driver's field of vision.

2.2.8.3. Operation: appearance of a green light when the number-plate lighting device is switched on.

2.2.8.4. Identification: mandatory if a telltale is fitted.

2.2.9 Main-beam-headlamps telltale (actuating telltale)

2.2.9.1. Installation: mandatory if main-beam headlamps fitted.

2.2.9.2. Location: within the driver's field of vision.

2.2.9.3. Operation: appearance of a blue light when the switch is actuated.

2.2.9.4. Identification: mandatory if a telltale is fitted.

2.2.10. Reversing-light(s) telltale

2.2.10.1. Installation: optional.

2.2.10.2. Location: within the driver's field of vision.

2.2.10.3. Operation: appearance of a green light when the switch is actuated.

2.2.10.4. Identification: mandatory if a telltale is fitted.

2.2.11. Rear-foglamp(s) telltale (actuating telltale)

2.2.11.1. Installation: mandatory if rear foglamp(s) fitted.

- 2.2.11.2. Location: within the driver's field of vision.
- 2.2.11.3. Operation: appearance of an amber light when the rear fog lamp(s) is/are switched on.
- 2.2.11.4. Identification: mandatory if a telltale is fitted.

- 2.2.12. Battery-charging telltale
- 2.2.12.1. Installation: optional.
- 2.2.12.2. Location: within the driver's field of vision. May be placed in or close to battery charging indicator, if fitted.
- 2.2.12.3. Operation: appearance of a red light when the battery is not being charged.
- 2.2.12.4. Identification: mandatory.

- 2.2.13. Fuel-level telltale
- 2.2.13.1. Installation: optional.
- 2.2.13.2. Location: within the driver's field of vision. May be placed in or close to fuel level indicator, if fitted.
- 2.2.13.3. Operation: appearance of an amber light when the fuel level is almost down to zero or the tractor is operating on its reserve fuel supply.
- 2.2.13.4. Identification: mandatory.

- 2.2.14. Overheated engine telltale
- 2.2.14.1. Installation: optional.
- 2.2.14.2. Location: within the driver's field of vision; may be placed in or close to engine thermometer, if fitted.

- 2.2.14.3. Operation : appearance of a red light when, by reference to the manufacturer's specifications, the engine becomes overheated.
- 2.2.14.4. Identification : mandatory if a telltale is fitted.
- 2.2.15. Lubricating-oil pressure telltale
- 2.2.15.1. Installation : optional.
- 2.2.15.2. Location : within the driver's field of vision. May be placed in or close to lubricating-oil pressure indicator, if fitted.
- 2.2.15.3. Operation : appearance of a red light when the lubricating-oil pressure in the engine lubrication system falls below the normal operating threshold specified by the manufacturer.
- 2.2.15.4. Identification : mandatory if a telltale is fitted.
- 2.3. INDICATORS
- 2.3.1. Battery charging indicator
- 2.3.1.1. Installation : optional.
- 2.3.1.2. Location : within the driver's field of vision.
- 2.3.1.3. Operation : indicates whether or not the battery is being charged.
- 2.3.1.4. Identification : mandatory if a telltale is fitted.
- 2.3.2. Fuel level indicator
- 2.3.2.1. Installation : optional.
- 2.3.2.2. Location : within the driver's field of vision.
- 2.3.2.3. Operation : indicates fuel level in the tank.

2.3.2.4. Identification: mandatory if a telltale is fitted.

2.3.3. Engine working temperature indicator

2.3.3.1. Installation: optional.

2.3.3.2. Location: within the driver's field of vision.

2.3.3.3. Operation: indication of the engine's working temperature.

2.3.3.4. Identification: mandatory if the indicator is fitted.

2.3.4. Lubricating-oil pressure indicator

2.3.4.1. Installation: optional.

2.3.4.2. Location: within the driver's field of vision.

2.3.4.3. Operation: indication of the state of the lubricating-oil
pressure in the engine lubrication system.

2.3.4.4. Identification: mandatory if the indicator is fitted.

ANNEX III

SYMBOLS

1. Starter control

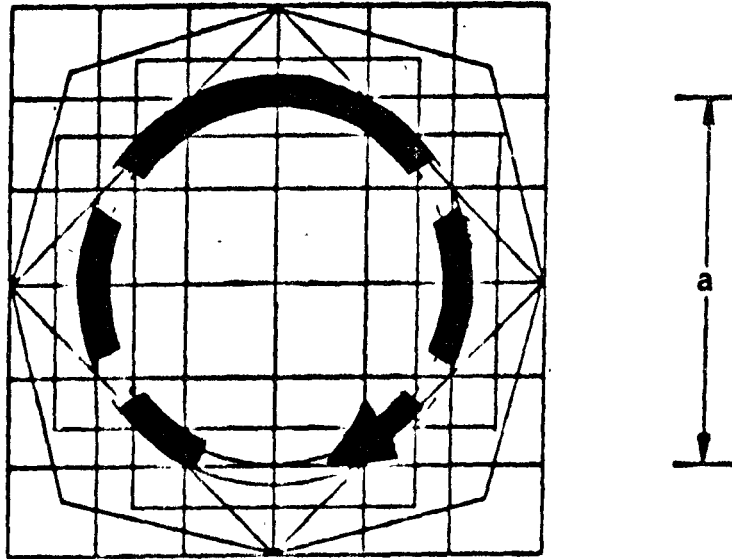

2. Engine speed control

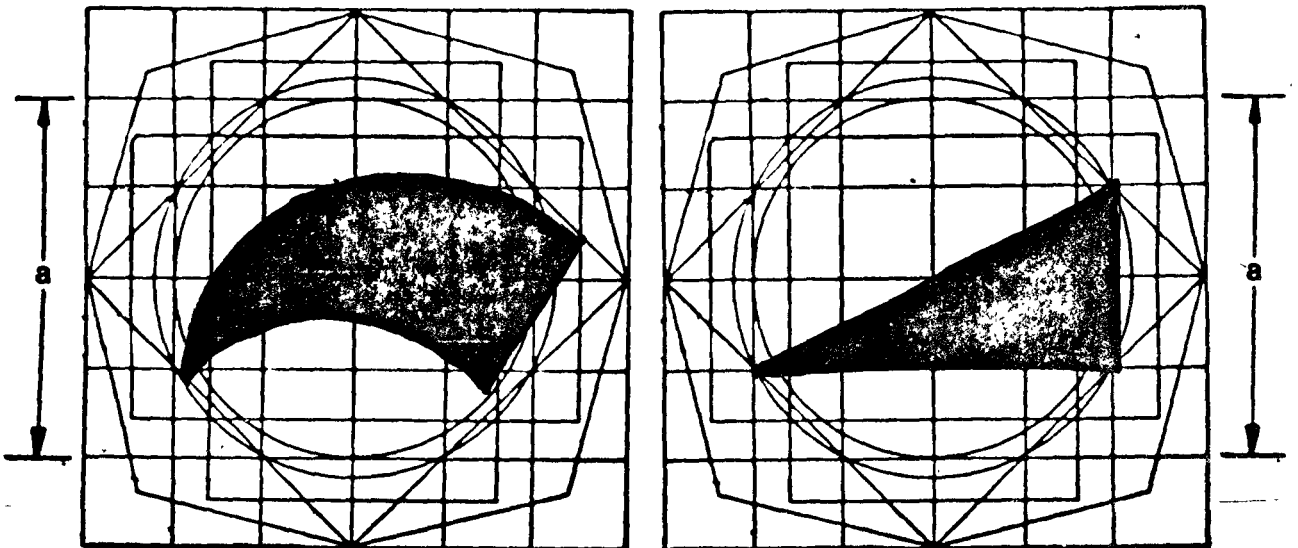

Signification : continuous rotary
variation

continuous linear variation

3. Tractor speed and direction-of-travel control

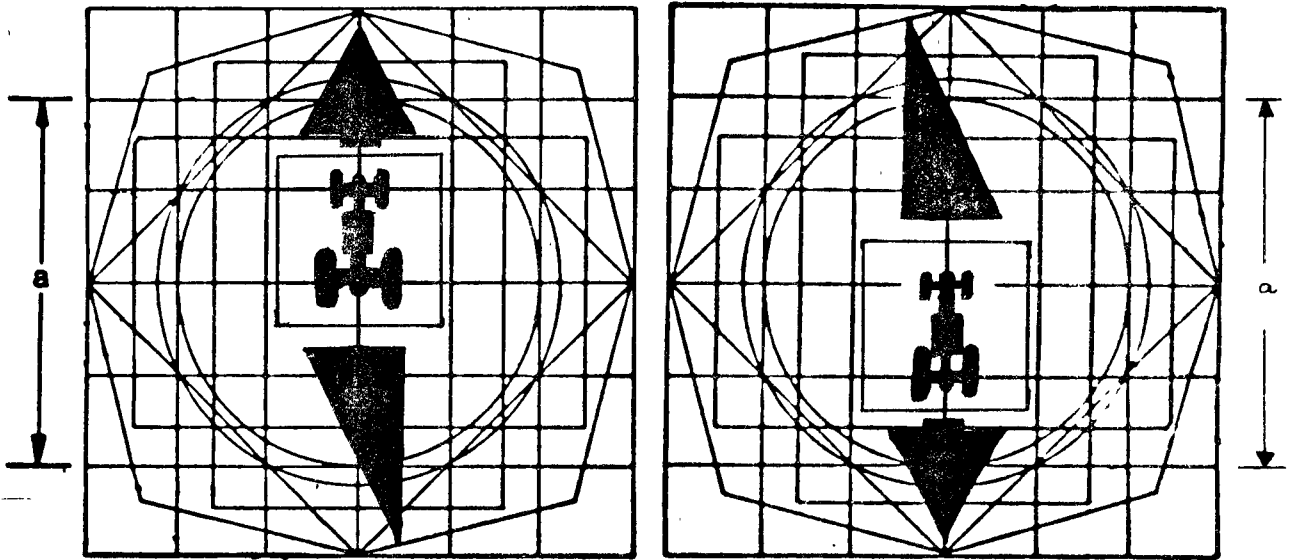

Signification : forward

reverse

4. Engine shut-off control (Spark ignition engine and compression ignition engine)

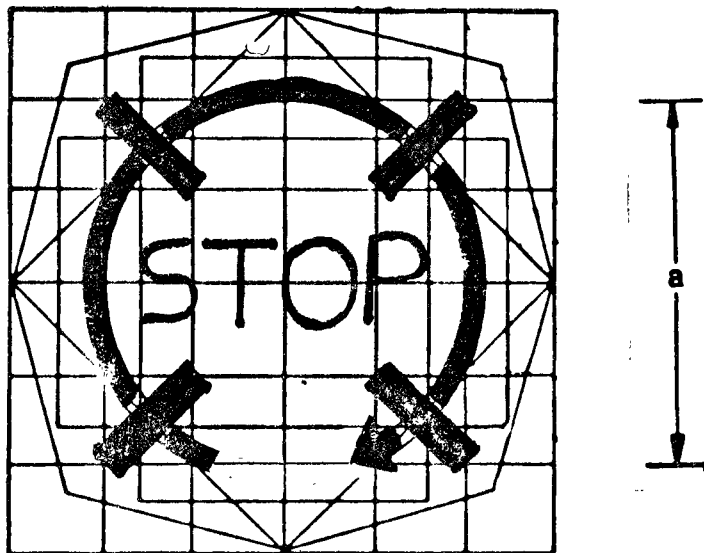

5. Parking brake control and related actuating telltale

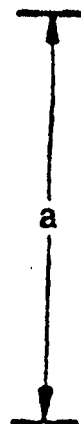
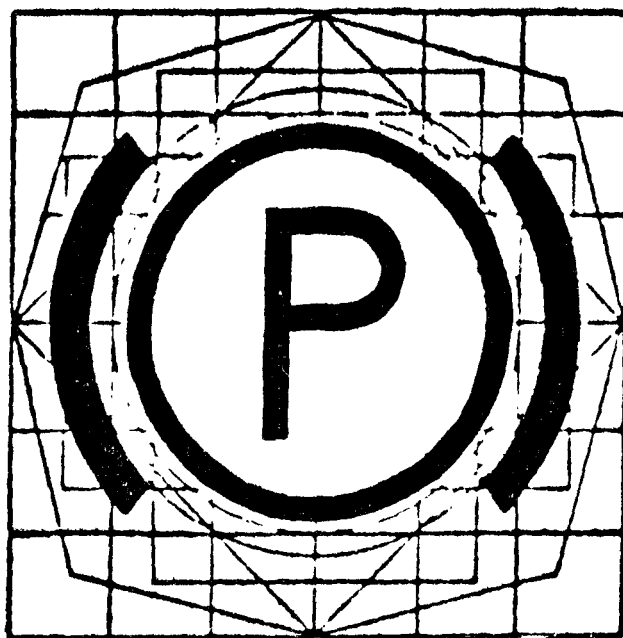

6. Differential lock control and related actuating telltale

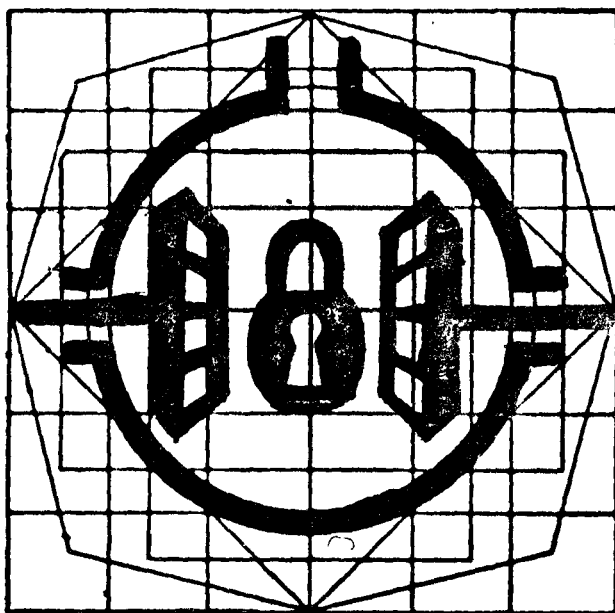

Signification : Differential lock actuated

7. Power take-off clutch control and related actuating telltale

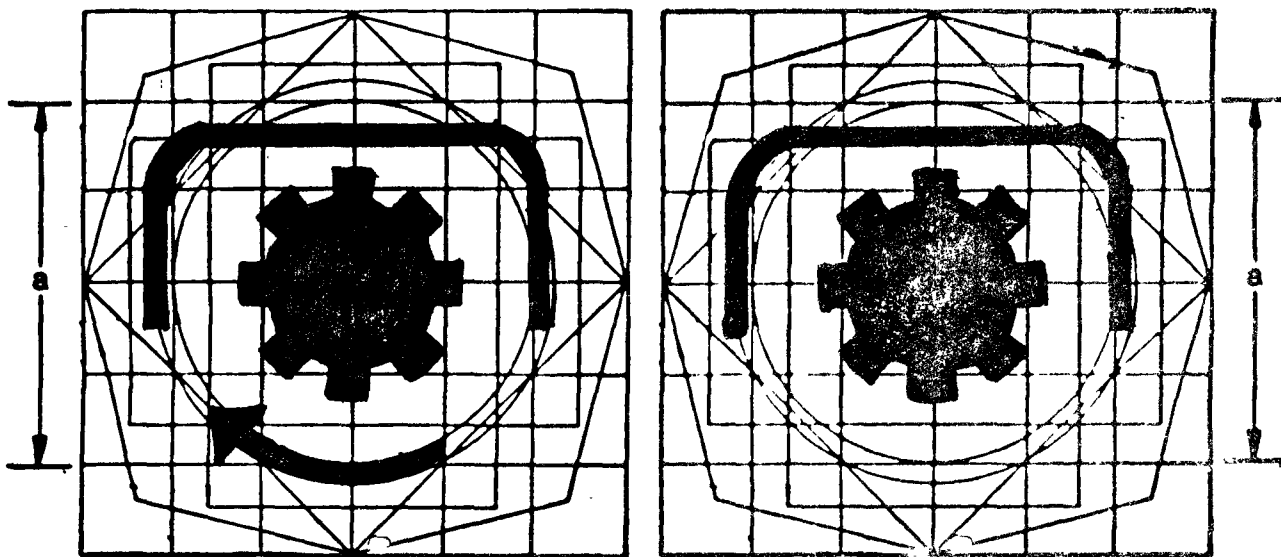

Signification "On" position

"off" position

8. Power-take-off actuator and/or rotational-speed selector an related actuating telltale

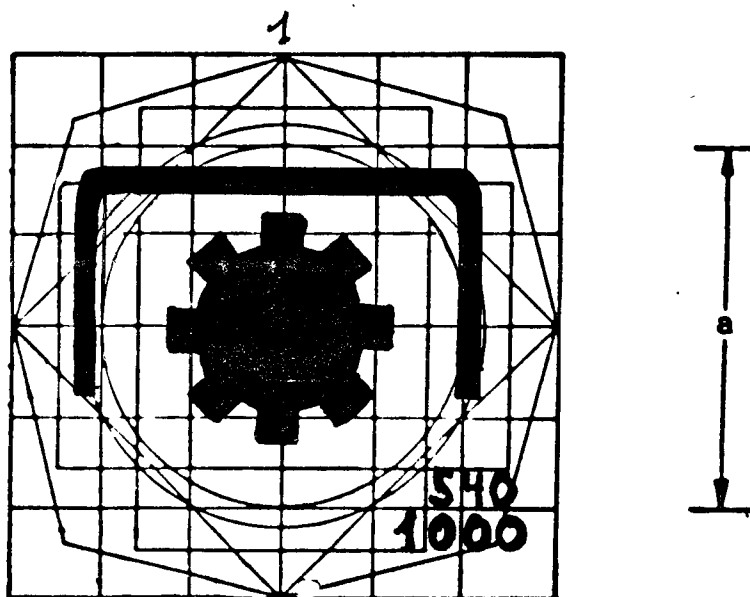

Signification : Unit disengaged and not actuated

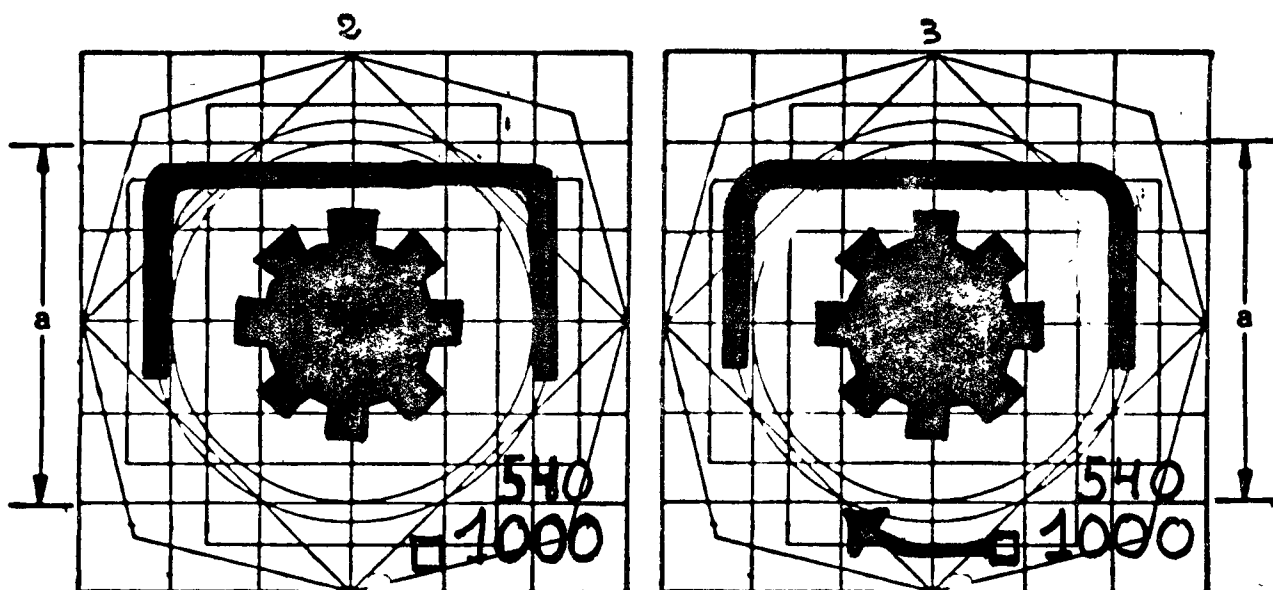

Signification : Unit actuated but not engaged

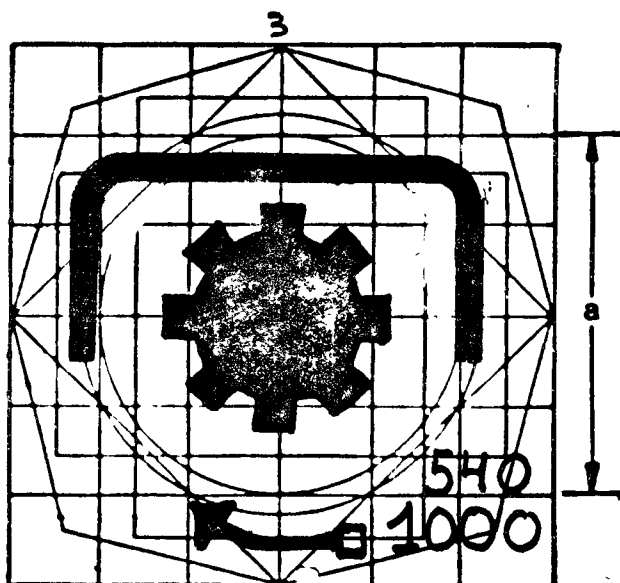

Unit engaged and actuated

NB. These symbols relate to the actuator and rotational-speed selector of a two-speed power take-off. In Symbol No 1 the selector is shown in neutral and disengaged; in Symbol No 2 the power take-off is seen to be set to rotate at 1 000 r.p.m., but not engaged, and in Symbol No 3 it is engaged and actuated at the rotational speed of 1 000 r.p.m.

9. Lift mechanism control

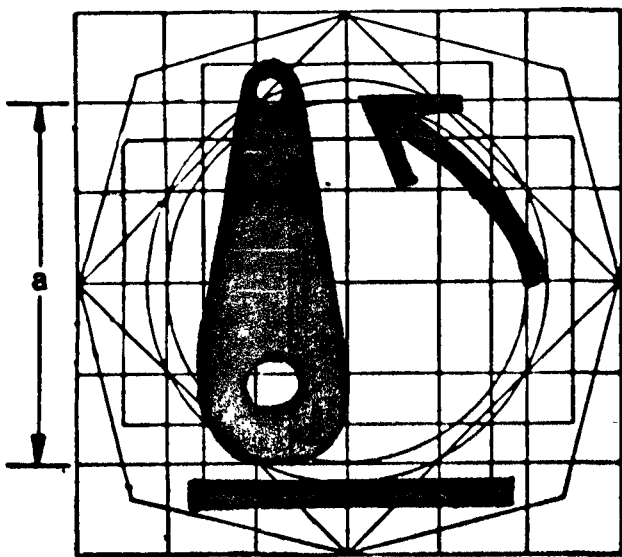

Signification : Raised position

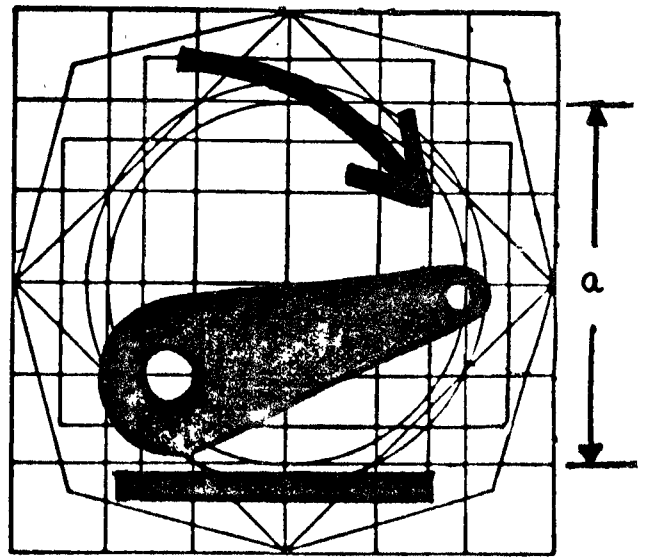

Lowered position

10. Device(s) for remote control of external services

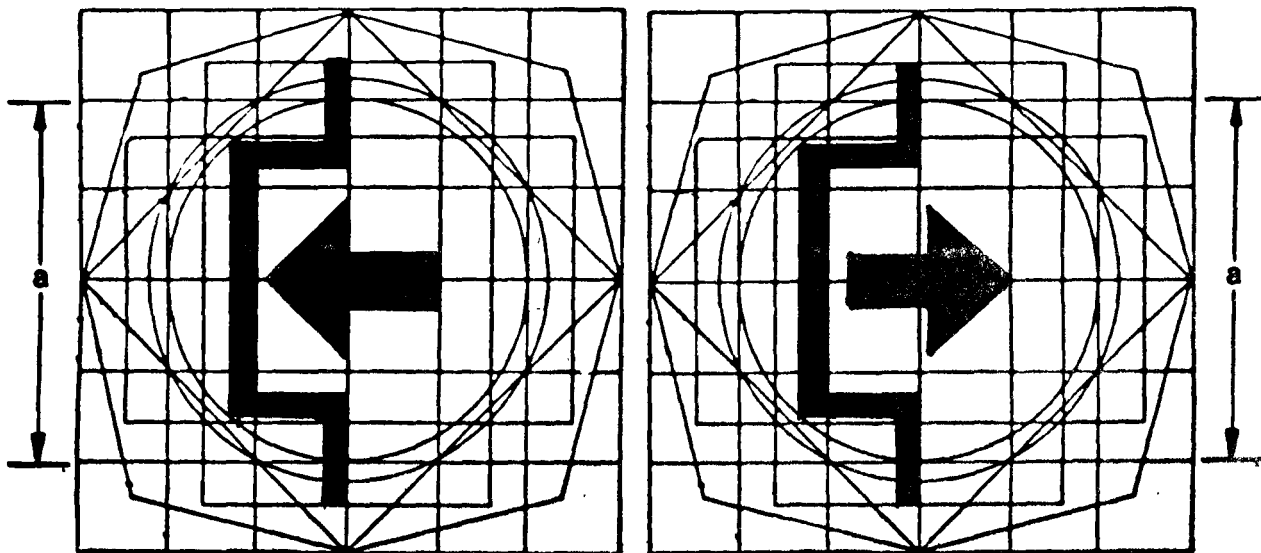

Signification : "On" position

"Off" position

11. Dipped-headlamps switch and related actuating telltale

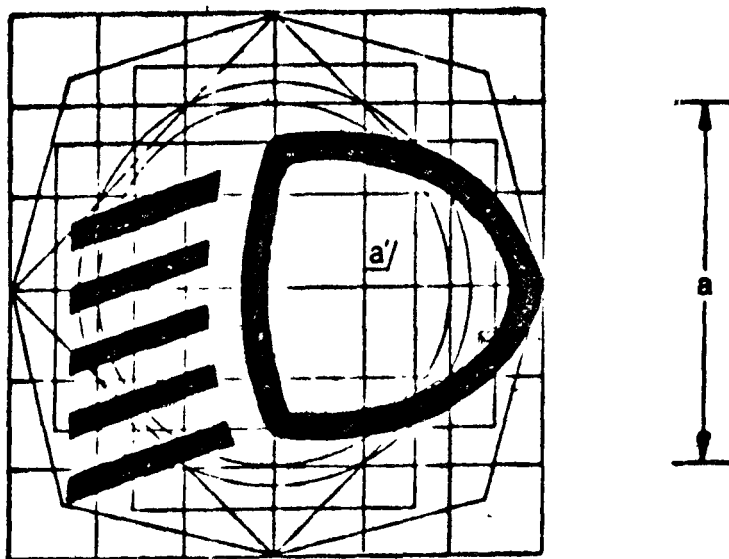

12. On/off-selector switch for direction-indicator lights and related operating telltale

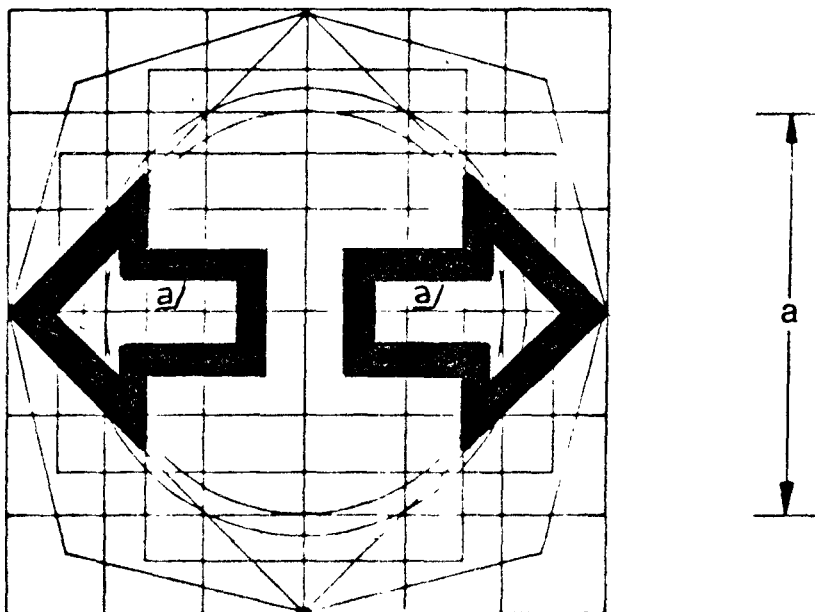

13. Hazard-warning light switch and related actuating telltale

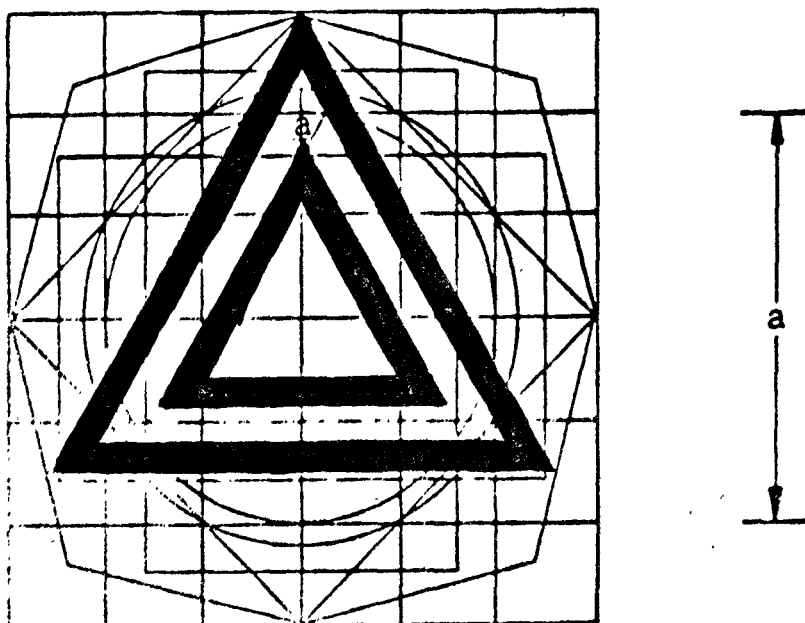

14. Master lighting switch and actuating telltale or combined on/off selector switch for lighting

14 a. Control for sidelights

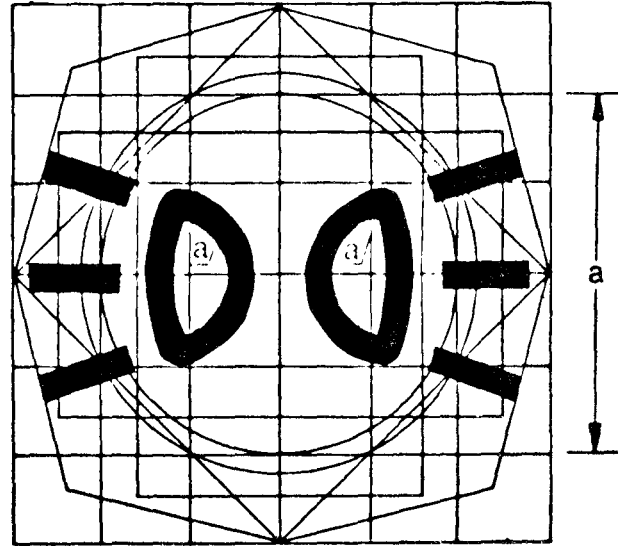
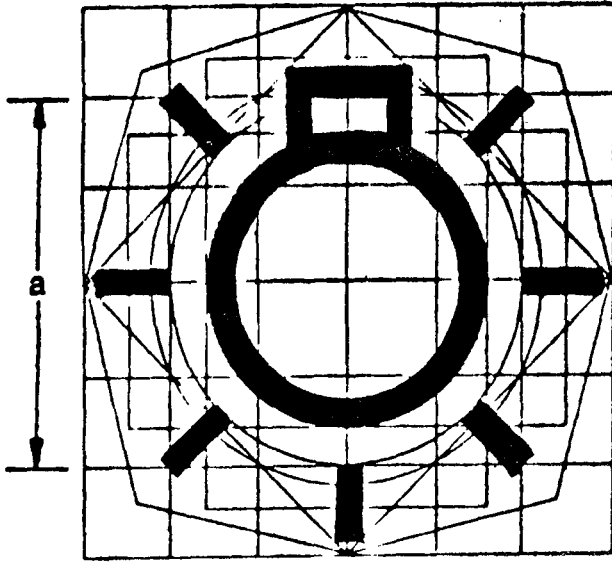

15. Main-beam headlamps switch and related operating telltale

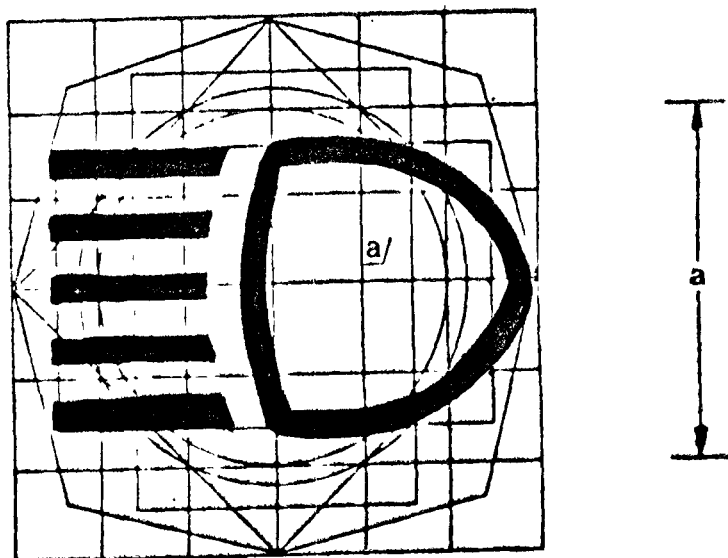

16. Front fog lamps switch and related actuating telltale



17. Rear fog lamp(s) switch and related actuating telltale

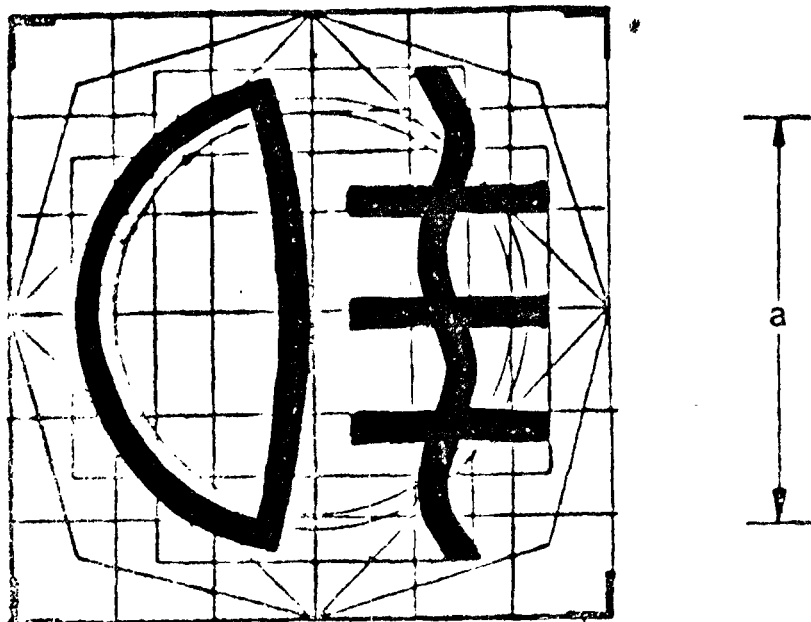

18. On/off-selector switch for parking light(s) and related actuating telltale

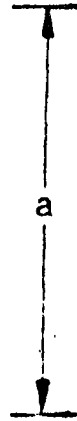
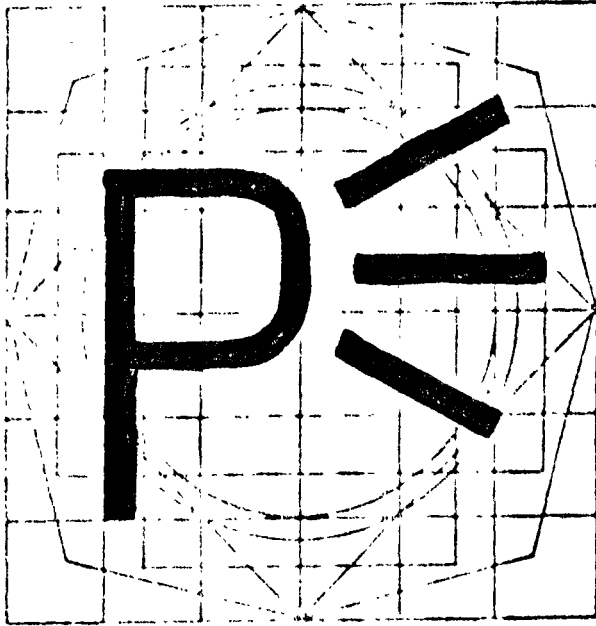

19. Working light switch

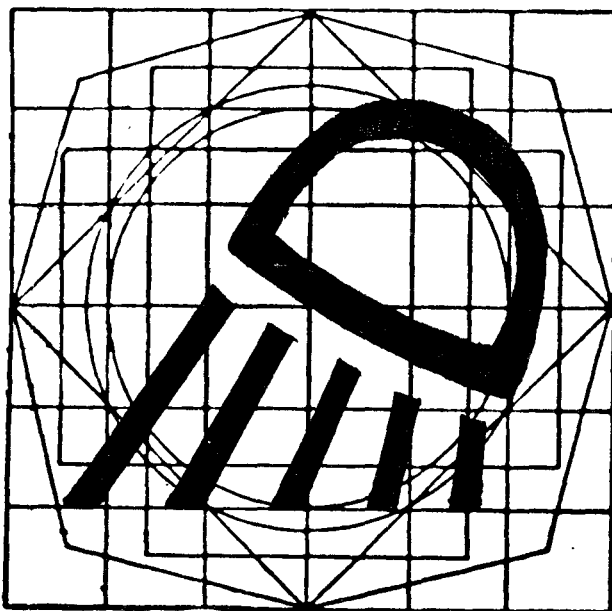

20. Windscreen wiper switch

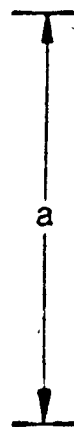
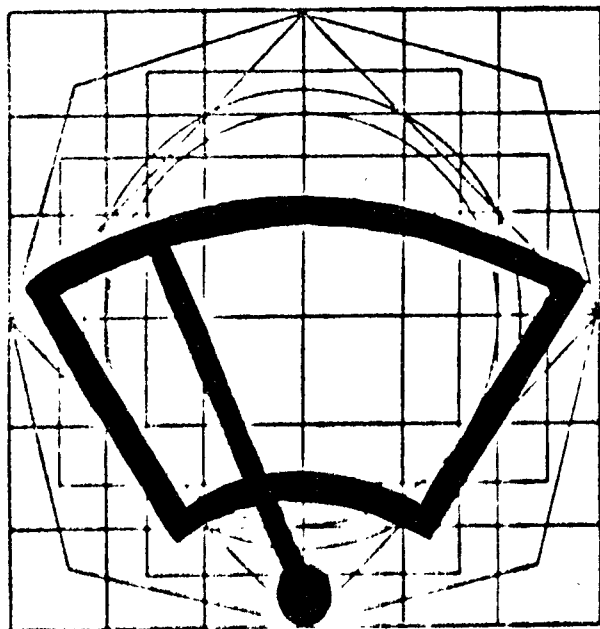

21. Reversing light(s) control and related actuating telltale

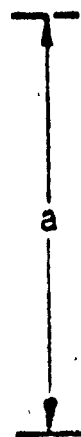
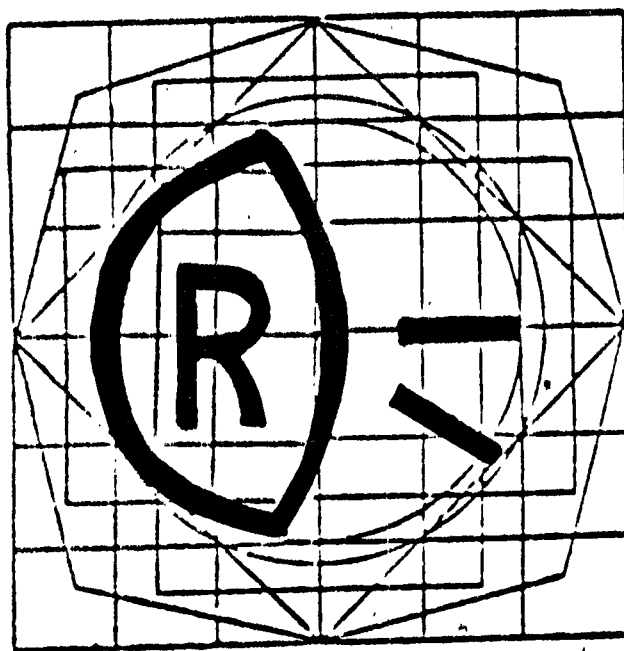

22. Battery charging indicator and related telltale

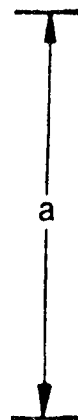
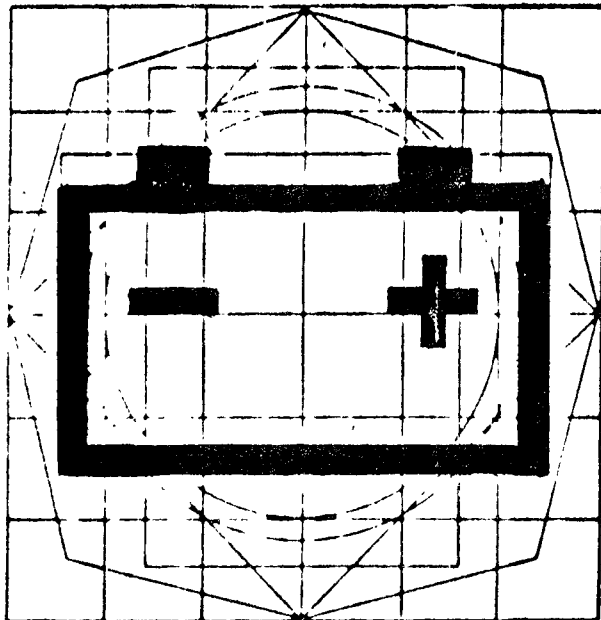

23. Fuel-level indicator and related telltale

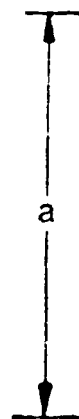
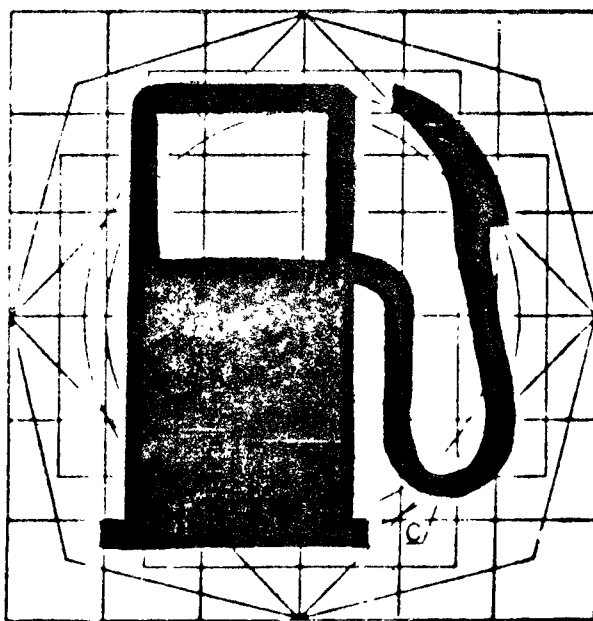

24. Engine working temperature indicator and related telltale

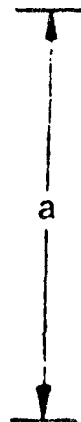
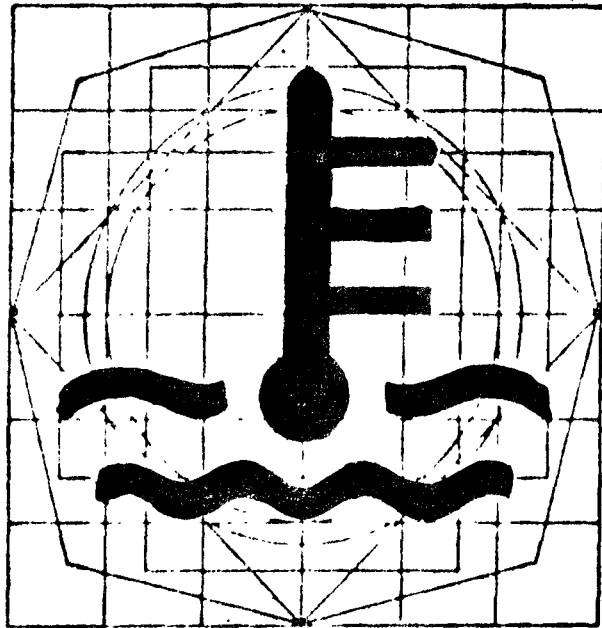

25. Lubricating-oil pressure indicator and related telltale

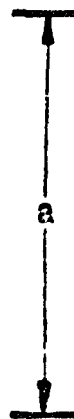
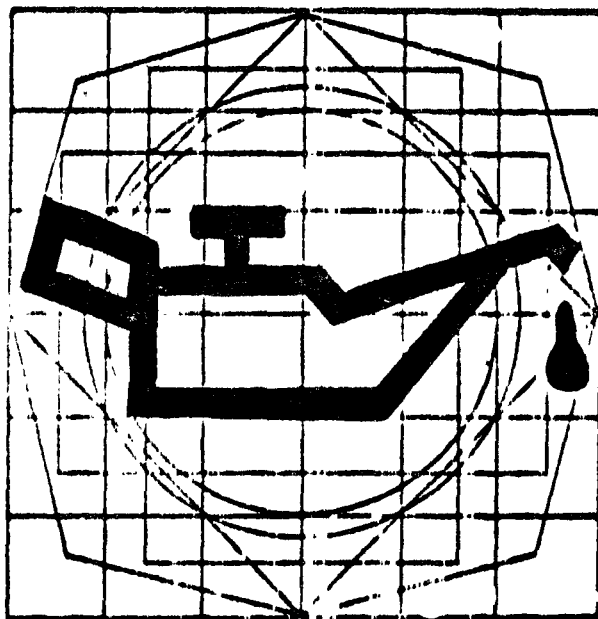

26. Audible warning device control

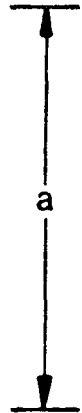
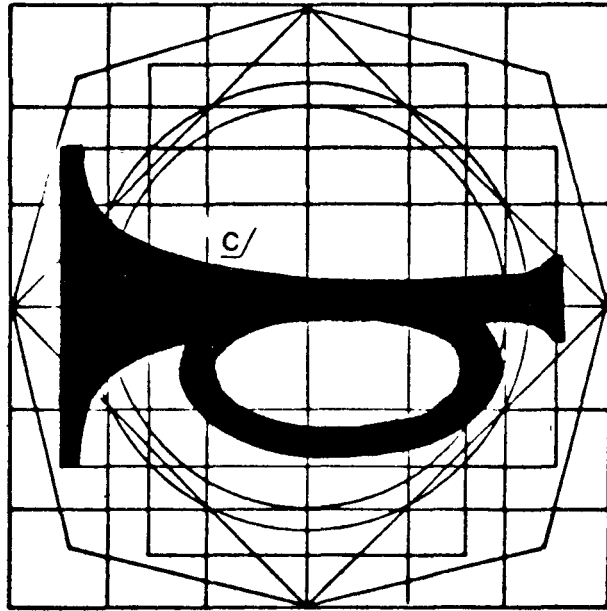

ANNEX IV

CONSTRUCTION OF THE BASIC MODEL FOR THE SYMBOLS SHOWN IN ANNEX III

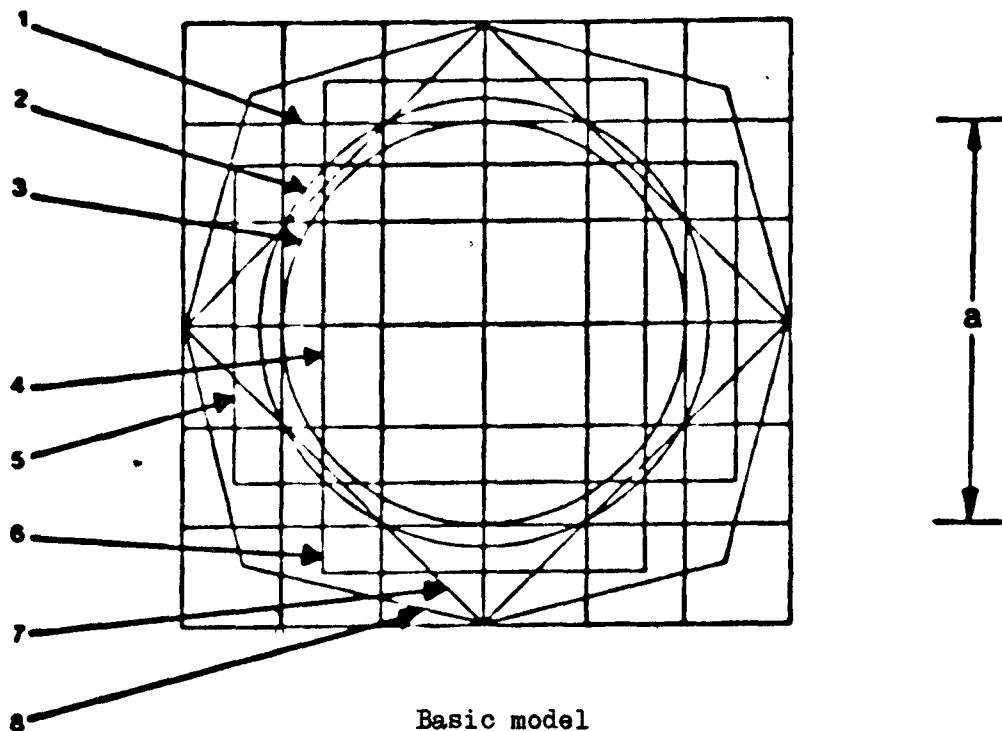

The basic model consists of:

1. a basic square measuring 50 x 50 mm, the dimension a) being equal to the nominal dimension a) of the original;
2. a basic circle, 56 mm in diameter, having approximately the same surface area as the basic square (1);
3. a second circle, 50 mm in diameter, inscribed within the basic square (1);
4. a second square whose rightangles are situated on the basic circle (2) and whose sides are parallel to the sides of the basic square (1);
5. and 6. two rectangles having the same surface area as the basic square (1); their respective sides are perpendicular and each of them is constructed in such a way as to intersect the opposite sides of the basic square at symmetrical points;

7. a third square whose sides pass through the points of intersection of the basic square (1) and of the basic circle (2) and are inclined at an angle of 45° , thus giving the largest horizontal and vertical dimensions of the basic model;
8. an irregular octagon formed by lines inclined at an angle of 30° to the sides of the square (7).

The basic model is situated on a 12.5 mm gauge grid which coincides with the basic square (1).

ANNEX V

MODEL

[Maximum format: A4 (210 x 297 mm)]

Name of
administration

ANNEX TO THE EEC TYPE-APPROVAL CERTIFICATE FOR A TRACTOR TYPE WITH REGARD TO THE LOCATION, INSTALLATION AND IDENTIFICATION OF CONTROLS, TELLTALES AND INDICATORS

(Article 4(2) and Article 10 of Council Directive 74/150/EEC of 4 March 1974 on the approximation of the laws of the Member States relating to the type-approval of wheeled agricultural or forestry tractors)

- EEC Type-Approval No
- 1. Trade mark of the tractor
-
- 2. Tractor type
- 3. Name and address of manufacturer
-
-
- 4. If applicable, name and address of manufacturer's authorized representative
-
-
- 5. Brief description of the tractor type with regard to the location, installation, operation and identification of controls, telltales, and indicators
-
-
- 6. Tractor submitted for type-approval on
- 7. Technical service responsible for type-approval tests
- 8. Date of report issued by that service
- 9. Number of report issued by that service
- 10. Type-approval as regards the location, installation, operation and identification of controls, telltales and indicators has been granted/
refused (*)
- 11. Place
- 12. Date
- 13. Signature

(*) Delete whichever is inapplicable

- 14. The following drawings, bearing the type-approval number shown above, are annexed to this communication:

A set of drawings of the controls, telltales and indicators and of the tractor components regarded as relevant for the purposes of Council Directive of on the approximation of the laws of the Member States relating to the location, installation, operation and identification of controls, telltales and indicators.

These drawings must be supplied to the competent authorities of the other Member States at their express demand.

- 15. Comments

