

COMMISSION OF THE EUROPEAN COMMUNITIES

COM(74) 895 final

Brussels, 20 June 1974

PROPOSAL FOR A COUNCIL DIRECTIVE

on the approximation of the laws of the Member States
relating to the braking devices of
wheeled agricultural or forestry tractors

PROPOSAL FOR A COUNCIL DIRECTIVE

on the approximation of the laws of Member States
relating to the installation of lighting and
light signalling devices on wheeled agricultural of forestry tractors

(submitted to the Council by the Commission)

PROPOSAL FOR A COUNCIL DIRECTIVE
ON THE APPROXIMATION OF THE LAWS OF THE MEMBER
STATES RELATING TO THE BRAKING DEVICES OF
WHEELED AGRICULTURAL OR FORESTRY TRACTORS.

EXPLANATORY MEMORANDUM

This proposed Directive is to form part of the Community type-approval procedure referred to in the Council Directive of 4 March 1974 (1).

The proposal concerns technical requirements for the construction and testing of the braking devices of wheeled agricultural or forestry tractors.

The Directive applies to wheeled agricultural or forestry tractors which have a maximum design speed of 6 to 25 km/h, as provided for in the Directive on type-approval (Article 1).

Article 2 incorporates the requirements for braking devices into the EEC type-approval procedure.

Since national type-approval procedures do not yet exist in all the new Member States, some provisions are to be included to ensure that tractors meeting the requirements of the Directive (Article 3) could be used in these States.

Article 4, is a safety measure in that it stipulates that, in the event of any modification of certain parts or characteristics of a tractor type, fresh tests may have to be carried out and, where appropriate, a fresh information document drawn up. It will rest with the authorities responsible for granting type-approval to decide whether or not any such modifications notified by the manufacturer shall constitute grounds for fresh tests and, consequently, the drawing-up of a fresh information document. A list of parts or characteristics affecting the performances of the braking devices is contained in Annex I.

Article 5 provides for the adaptation of the specifications in the Annexes in line with technical progress; the procedure is defined in Article 13 of the Council Directive of 4 March 1974 on the type-approval of wheeled agricultural or forestry tractors.

(1) O.J. N° L 84, 28 March 1974, p. 10.

Article 6 lays down two time-limits. Before the expiry of the first time-limit, the Member States must adopt and publish the measures necessary to comply with the Directive. The second time-limit is the date on which all the Member States must simultaneously apply the common rules (Article 6 (1)).

Finally, the Commission must be informed with reasonable notice of any provisions the Member States intend to enact in the field covered by the Directive; the information must be sufficient for the Commission to be able to comment on the proposed provisions if necessary (Article 6 (2)).

The technical annexes contain a number of definitions and give details of the EEC type-approval application procedure, the general and individual construction and test specifications for the various types of braking devices and also include a model form on which the authorities granting or refusing type-approval for the braking device enters information additional to the type-approval certificate provided for in the Directive.

In the case of one problem, however, it was not possible to devise a solution which met with the unanimous approval of all the experts in the Working Group on Agricultural Tractors and Machines. The French and Italian experts, in particular, opposed the imposition of a parking brake completely independent of the service braking for tractors fitted with a purely mechanical service braking device operated by a transmission formed by rigid elements. In such cases it can be claimed that the transmission of the service braking device is not subject to fracture and that it is just as reliable as the elements making up the vehicle's steering gear; consequently, it could be conceded that the mechanical transmission of a service braking device may form part of the transmission of the parking braking device. These same experts had not opposed the principle that the service and parking braking systems should be independently controlled and that actuation of the parking brake control should provide a braking effect. The Commission, however, was unable to accept this solution, since the experts from the other Member States were unanimously in favour of the proposal contained in subsection 4.2.2.2. of Annex I. The terms of this proposal are stricter as regards the provisions governing the characteristics of braking devices but run counter to the desire for much more lucid provisions and hence increased safety.

./.

CONSULTATION OF THE EUROPEAN PARLIAMENT AND ECONOMIC AND SOCIAL COMMITTEE

Pursuant to the provisions of Article 100 (2), the opinion of these two institutions is required.

./.

4

THE COUNCIL OF THE EUROPEAN COMMUNITIES

Having regard to the Treaty establishing the European Economic Community, and in particular Article 100 thereof;

Having regard to the proposal from the Commission;

Having regard to the Opinion of the European Parliament;

Having regard to the Opinion of the Economic and Social Committee;

Whereas the technical requirements which tractors must satisfy pursuant to national laws relate, inter alia, to the braking devices;

Whereas those requirements differ from one Member State to another; whereas it is therefore necessary that all Member States adopt the same requirements either in addition to or instead of their existing rules, in order, in particular, to allow the EEC type-approval procedure which was the subject of the Council Directive of 4 March 1974 on the approximation of the laws of Member States relating to the type approval of wheeled agricultural or forestry tractors to be applied in respect of each type of tractor;

Whereas the harmonized requirements are intended principally to improve safety on the road and at work throughout the whole Community;

Whereas the approximation of national laws relating to tractors includes reciprocal recognition by Member States of the tests carried out by them individually on the basis of the common requirements; whereas if the system is to function properly these requirements must be applied by all Member States from the same date;

HAS ADOPTED THIS DIRECTIVE:

Article 1

1. "Agricultural or forestry tractor" means any motor vehicle, fitted with wheels or caterpillar tracks, and having at least two axles, the main function of which lies in its tractive power and which is specially designed to tow, push, carry or power certain tools, machinery or trailers intended for agricultural or forestry use. It may be equipped to carry a load and passengers.

2. This Directive shall apply only to tractors defined in paragraph 1 above which are fitted with pneumatic tyres and which have two axles and a maximum design speed between six and twenty-five k.p.h.

Article 2

No Member State may refuse to grant EEC type-approval or national type-approval of a tractor on grounds relating to its braking devices if that tractor is fitted with the devices specified in Annexes I to IV and if these devices satisfy the requirements set out therein.

Article 3

No Member State may refuse the registration or prohibit the sale, entry into service or use of tractors on grounds relating to their braking devices if these tractors are fitted with the devices specified in Annexes I to IV and if these devices satisfy the requirements set out therein.

Article 4

The Member State which has granted type-approval shall take the necessary measures to be informed of any modification of a part or characteristic referred to in item 1.1. of Annex I. The competent authorities of that State shall determine whether fresh tests should be carried out on the modified type of tractor and a fresh report drawn up.

Where such tests reveal failure to comply with the requirements of this Directive, the modification shall not be approved.

.../...

Article 5

The amendments necessary for ~~adapting~~ to technical progress the requirements of the Annexes shall be adopted in accordance with the procedure laid down in Article 13 of the Council Directive of 4 March 1974 on the approximation of the laws of the Member States relating to the type-approval of wheeled agricultural or forestry tractors.

Article 6

1. The Member States shall adopt and publish the provisions needed in order to comply with this Directive before 1 October 1975 and shall forthwith inform the Commission thereof.

They shall apply these provisions from 1 October 1976.

2. As soon as this Directive has been notified, the Member States shall inform the Commission, in sufficient time to enable it to submit its comments, of any draft laws, regulations or administrative provisions which they intend to adopt in the field covered by the Directive.

Article 7

This Directive is addressed to the Member States.

ANNEX I

DEFINITIONS, APPLICATION FOR EEC TYPE-APPROVAL, EEC TYPE-APPROVAL, CONSTRUCTION AND FITTING REQUIREMENTS

1. DEFINITIONS

For the purposes of this directive :

1.1. "type of tractor with respect to the braking devices" means tractors which do not differ in such essential respects as :

- 1.1.1. unladen weight, as defined in item 1.18 hereinafter,
- 1.1.2. maximum weight, as defined in item 1.16 hereinafter,
- 1.1.3. distribution of the unladen weight,
- 1.1.4. technically admissible maximum weight on each axle,
- 1.1.5. maximum design speed,
- 1.1.6. different type of braking device (with particular reference to the presence or otherwise of devices for braking a trailer),
- 1.1.7. number and arrangement of the braked axles,
- 1.1.8. type of engine,
- 1.1.9. overall transmission ratio corresponding to maximum speed,
- 1.1.10. tyre dimensions;

1.2. "braking device" means the combination of parts whose function is progressively to reduce the speed of a moving tractor or to bring it to a halt, or to keep it stationary if it already halted. These functions are specified in item 4.1.2. below.
The device shall consist of the brake control, the transmission and the brake proper;

1.3. "graduated braking" means braking during which, within the normal range of operation of the device, during either the application or the releasing of the brakes :

- 1.3.1. the driver may at any time, increase or reduce the braking force through action on the control,
- 1.3.2. the braking force acts in the same direction as the action on the control (monotonic function),
- 1.3.3. it is easily possible to make a sufficiently fine adjustment to the braking force;

Annex I

- 1.4. "control" means the part actuated directly by the driver to supply to the transmission the energy required for braking or controlling it. This energy may be the muscular energy of the driver, or energy from another source controlled by the driver, or in appropriate cases the kinetic energy of the trailer, or a combination of these various kinds of energy;
- 1.5. "transmission" means the combination of components situated between the control and the brake and connecting the two operationally. The transmission may be mechanical, hydraulic, pneumatic, electrical, or mixed. Where the braking power is derived from or assisted by a source of energy independent of the driver but controlled by him, the reserve of energy in the device shall likewise be regarded as part of the transmission;
- 1.6. "brake" means the component in which the forces opposing the movement of the tractor develop. It may be a friction brake (when the forces are generated by the friction between two parts of the tractor moving relatively to one another), an electrical brake (when the forces are generated by electromagnetic action between two parts of the tractor moving relatively to but not in contact with one another), a fluid brake (when the forces are generated by the action of a fluid situated between two parts of the tractor moving relatively to one another), or an engine brake (when the forces are derived from a controlled increase in the braking action of the engine transmitted to the wheels). A device which mechanically locks the tractor's transmission but which cannot be used when the tractor is in motion shall be deemed to be a brake, for parking brake purpose only;
- 1.7. "different types of braking devices" means equipment which differs in such essential respects as :
 - 1.7.1. components having different characteristics,
 - 1.7.2. a component made of materials having different characteristics or a component different in shape or size,
 - 1.7.3. a different assembly of the components;

./.

Annex I

- 1.8. "braking system component" means one of the individual parts which, when assembled, constitute the braking device,
- 1.9. "continuous braking" means the braking of combinations of vehicles (tractors plus towed vehicles) through an installation having the following characteristics :
- 1.9.1. a single control which the driver actuates progressively, by a single movement, from his driving seat,
- 1.9.2. the energy used for braking the vehicles constituting the vehicle combination is supplied from the same source (which may be the muscular energy of the driver),
- 1.9.3. the braking installation ensures simultaneous or suitably phased braking of each of the constituent vehicles of the combination, whatever their relative positions.
- 1.10. "semi-continuous braking" means the braking of combinations of vehicles (tractors plus towed vehicles) through an installation having the following characteristics :
- 1.10.1. a single control which the driver actuates progressively, by a single movement, from his driving seat,
- 1.10.2. the energy used for braking the vehicles constituting the vehicle combination is supplied from two different sources (one of which may be the muscular energy of the driver),
- 1.10.3. the braking installation ensures simultaneous or suitably phased braking of each of the constituent vehicles of the combination, whatever their relative positions;
- 1.11. "independent power-operated braking" means the braking of combinations of vehicles (tractors plus towed vehicles) by means of devices having the following characteristics :
- 1.11.1. the brake control of the tractor is independent of the trailer brake control; the latter is in all cases mounted on the tractor in such a way that it shall be easily actuated by the driver from his driving seat;
- 1.11.2. the energy used for braking the towed vehicles may not be the muscular energy of the driver.

- 1.12. "independent braking" means the braking of combinations of vehicles by means of devices having the following characteristics :
- 1.12.1. the brake control of the tractor is independent of the trailer brake control, the latter being in all cases mounted on the tractor in such a way that it shall be easily actuated by the driver from his driving seat;
- 1.12.2. the energy used for braking the trailers is the muscular energy of the driver;
- 1.13. "automatic braking" means braking of the trailer or trailers occurring automatically in the event of separation of components of the combination of coupled vehicles, including such separation through coupling breakage, without the effectiveness of the remainder of the combination being affected;
- 1.14. "inertia braking" means braking by utilising the forces generated by the trailer moving up on the tractor;
- 1.15. "laden tractor" means, except where otherwise stated, a tractor laden to its "maximum weight";
- 1.16. "maximum weight" means the maximum weight technically permissible stated by the manufacturer (this weight may be higher than the "permissible maximum weight");
- 1.17. "unladen tractor" means the tractor in running order, with full tanks and radiators, a driver weighing 75 kg, without passengers, optional accessories or load;
- 1.18. "unladen weight" means the weight of the unladen tractor.

2. APPLICATION FOR EEC TYPE-APPROVAL

- 2.1. The application for EEC type-approval shall be submitted by the manufacturer or by his authorized representative.
- 2.2. It shall be accompanied by the following information and documents in triplicate :
- 2.2.1. description of the type of tractor as regards the points mentioned in items 1.1.1. to 1.1.10. above. The numbers and/or symbols identifying the type of tractor must be given;

./.

- 2.2.2. list of parts, properly identified, which make up the braking device,
- 2.2.3. diagram of the braking device showing the position of each of the parts on the tractor, in order to enable the various components to be located and identified.
- 2.3. Drawing, having a maximum format A₄, or folded to this size, and drawn to the appropriate scale, shall be placed at the disposal of the technical service responsible for type-approval tests, if so required by that service .
- 2.4. A tractor, representative of the type of tractor to be approved, shall be placed at the disposal of the technical service, responsible for EEC type-approval tests.

3. EEC TYPE-APPROVAL

A form conforming to the model shown in Annex V shall be attached to the EEC type-approval certificate.

4. CONSTRUCTION AND FITTING REQUIREMENTS

4.1. General

4.1.1. Braking device

4.1.1.1. The braking device shall be so designed, constructed and fitted as to enable the tractor in normal use, despite the vibration to which it may be subjected, to comply with the undermentioned requirements.

4.1.1.2. In particular, the braking device shall be so designed, constructed and fitted as to be able to avoid the effects of ageing and corrosion during service which may lead to a sudden loss of braking efficiency.

4.1.2. Functions of the braking device

The braking device defined in item 1.2. above shall meet the following conditions :

4.1.2.1. Service braking

4.1.2.1.1. The service brake shall enable the motion of the tractor to be controlled and the tractor to be stopped safely, quickly and efficiently at maximum speed and authorized load on both up- and down-grades. It shall be possible to moderate its action. These conditions are fulfilled if the requirements of Annex II are satisfied.

The driver shall be able to actuate the brakes from his seat and retain control of the steering device of the tractor with at least one hand. The service brake of the tractor may comprise right and left hand devices. These shall be capable of being rigidly connected so that they can be actuated in a single operation. It shall be possible for this connection to be broken. Tractors braked by their steering mechanism may have two separate controls which can be uncoupled if the maximum design speed does not exceed 15 km/h.

4.1.2.2. Parking braking

The parking braking shall enable the tractor to be held stationary on an up or down gradient even in the absence of the driver, the working parts being then held in the locked position by a purely mechanical device. This may be achieved by means of a brake acting on the transmission. The driver shall be able to achieve this braking action from his driving seat; a repeated action to obtain the prescribed performance is permitted.

4.2. Characteristics of braking devices

4.2.1. The set of braking devices with which a tractor is equipped shall satisfy the requirements laid down for the service and parking brakes.

4.2.2. The devices providing service and parking braking may have common components, provided that they fulfil the following conditions :

4.2.2.1. there shall be at least two controls, independent of each other and readily accessible to the driver from the driving seat; this requirement shall be met even when the driver is wearing a safety belt;

4.2.2.2. in the event of a breakage of any component other than the brakes (as defined in item 1.6. above) or of any other failure of the service braking device (malfunction, partial or total exhaustion of an energy reserve), the parking braking device or that part of the service braking device which is not affected by the failure must be able to bring the tractor to a halt with a deceleration equal to at least 50 % of the value laid down in item 2.1.1. of Annex II. These conditions shall be fulfilled when residual braking is achieved on wheels located on both sides of the median longitudinal plane (without the tractor deviating from its course).

./.

- 4.2.3. Where use is made of energy other than the muscular energy of the driver, there need not be more than one source of such other energy (hydraulic pump, air compressor, etc.) but the means by which the device constituting that source is driven shall be completely reliable.
- 4.2.4. The service braking device shall act on the wheels of at least one axle.
- 4.2.5. The action of the service braking device shall be distributed between the wheels of the same axle symmetrically in relation to the longitudinal median plane of the tractor.
- 4.2.6. The service braking device and the parking braking device shall act on braking surfaces permanently connected to the wheels through components of adequate strength. It shall not be possible to disconnect a braking surface from the wheels. When one axle is subject to braking, the differential shall not be mounted between the service brake and the wheel; when two axles are subject to braking, the differential may be mounted between the service brake and the wheel on one of the two axles.
- 4.2.7. Wear on the brakes shall be easily compensated by means of a system of manual or automatic adjustment. In addition, the control and the components of the transmission and of the brakes become heated or when the brake linings have reached a certain degree of wear, effective braking is ensured without an immediate adjustment being necessary.
- 4.2.8. In hydraulic braking devices, the filling ports of the fluid reservoirs shall be readily accessible; in addition, the containers of reserve fluid shall be so made that the level of the reserve fluid can be easily checked without the containers having to be opened.

.../...

- 4.2.9. Every tractor fitted with a brake actuated from an energy reservoir shall, where the prescribed braking performance is impossible without the use of stored energy, be fitted with a warning device, in addition to the pressure gauge, giving an optical or acoustical signal when the energy, in any part of the installation upstream of the control valve, falls to a value equal or less than 65% of its normal value. This device shall be directly and permanently connected to the circuit.
- 4.2.10. Without prejudice to the requirements of item 4.1.2.1. above, where the use of an auxiliary energy source is essential for the operation of a braking device, the energy reserve shall be such as to ensure that, should the engine stop, the braking performance remains sufficient to bring the tractor to a halt in the prescribed conditions.
- 4.2.11. The auxiliary equipment shall draw its energy only in such a way that its operation, even in the event of damage to the energy source, cannot cause the reserves of energy feeding the braking devices to fall below the level indicated in item 4.2.9. above.

ANNEX II

BRAKING TESTS AND PERFORMANCE OF BRAKING DEVICES

1. BRAKING TESTS

1.1. General

- 1.1.1. The performance prescribed for braking devices shall be based on the measurement of the mean deceleration.
- 1.1.2. For the type-approval of any tractor the braking performance shall be measured during road tests conducted in the following conditions :
 - 1.1.2.1. the tractor's condition as regards weight shall be as prescribed for each type of test and be specified in the test report;
 - 1.1.2.2. during the tests the force applied to the brake control in order to obtain the prescribed performance shall not exceed 60 kg on the pedal controls and 40 kg on the hand-operated controls;
 - 1.1.2.3. the road must have a surface affording good adhesion;
 - 1.1.2.4. the tests shall be performed when there is no wind liable to affect the results;
 - 1.1.2.5. at the start of the tests the tyres shall be cold and at the pressure prescribed for the load actually borne by the wheels when the tractor is stationary;
 - 1.1.2.6. the prescribed performance shall be obtained without locking of the wheels, without deviation of the tractor from its course, and without abnormal vibrations.
- 1.1.3. During the tests, the tractor shall be fitted with all the braking devices intended by the manufacturer for the towed vehicles as referred to in items 1.9, 1.10, 1.11 and 1.13 of annex I.

1.2. Type 0 test
(ordinary performance test with brakes cold)

1.2.1. General

- 1.2.1.1. The brakes shall be cold. A brake is deemed to be cold if any one of the following conditions are met :
 - 1.2.1.1.1. the temperature measured on the disc or on the outside of the drum does not exceed 100° C,
 - 1.2.1.1.2. in the case of totally enclosed brakes, including oil immersed brakes, the temperature measured on the outside of the housing does not exceed 50° C.
 - 1.2.1.1.3. The brakes have not been actuated for one hour.

- 1.2.1.2. During the braking test the non-braked axles, when they are capable of being declutched, shall not be connected with the braked axles.
- 1.2.1.3. The test shall be conducted in the following conditions:
 - 1.2.1.3.1. The tractor shall be laden to its technically permissible maximum weight, the unbraked axle has to be loaded to its technically permissible maximum weight and the braked axle wheels have to be fitted with the largest dimensioned tyres intended for that type by the manufacturer. For tractors braking on all wheels, the front axle has to be laden to its maximum permissible weight;
 - 1.2.1.3.2. the test shall be repeated on an unladen tractor carrying only the driver and if necessary a person responsible for monitoring the results of the test; the tractor shall be fitted with the largest dimensioned tyres;
 - 1.2.1.3.3. the limits prescribed for minimum performance, both for test with the tractor unladen and for test with it laden, shall be those laid down in item 2.1.1. below;
 - 1.2.1.3.4. the road shall be level.
- 1.2.2. The type 0 test shall be carried out:
 - 1.2.2.1. at the maximum design speed with the engine uncoupled;
 - 1.2.2.2. a tolerance of $\pm 10\%$ is permitted on the test speed;
 - 1.2.2.3. the minimum prescribed performance shall be attained.
- 1.3. Type I test
(Fade test)
 - 1.3.1. Laden tractors shall be tested in such a manner that the energy input is equivalent to that recorded in the same period of time with a laden tractor driven at a steady speed $80\% \pm 5\%$ of that laid down for type 0 test on a 10% down gradient for a distance of 1 Km, with the engine uncoupled.
 - 1.3.2. At the end of the test, the residual performance of the service braking device shall be measured in the same conditions as for the Type 0 test with the engine uncoupled (the temperature conditions, of course, are different).

Annex II

2. PERFORMANCE OF BRAKING DEVICES2.1. Service braking devices

2.1.1. The service brakes of tractors shall :

2.1.1.1. under Type 0 test conditions, produce a mean deceleration of at least 2.5 m/s^2 , measured with a decelerameter;

2.1.1.2. after Type I test, produce a residual performance not less than 75 % of that prescribed, and not less than 60 % of the value recorded during the type 0 test (with engine uncoupled).

2.2. Parking braking devices

2.2.1. The parking braking device shall, even if it is combined with one of the other braking devices, be capable of holding a laden vehicle stationary on an 18 % up or down gradient.

2.2.2. On tractors to which the coupling of one or more trailers is authorized, the parking braking device of the tractor shall be capable of holding the vehicle combination, comprising an unladen tractor and an unbraked trailer of the same weight, stationary on a 12 % gradient.

2.2.3. A parking braking device which has to be actuated several times before attaining the prescribed performance is admissible.

ANNEX III

SPRING BRAKES

1. DEFINITION

"Spring brakes" are braking devices for which the energy required for braking is supplied by one or more springs acting as an energy accumulator.

2. SPECIAL REQUIREMENTS

- 2.1. A spring brake shall not be used as a service brake.
- 2.2. A small variation in any of the pressure limits which may occur in the brake compression chamber feed circuit shall not cause a significant variation in the braking force.
- 2.3. The feed circuit to the spring compression chamber shall include an energy reserve which does not supply any other device or equipment. This requirement shall not apply if the spring shall be maintained in the compressed state by using two or more independent systems.
- 2.4. The device shall be so designed that it is possible to apply and release the brakes at least three times starting with an initial pressure in the spring compression chamber equal to the maximum design pressure. This requirement shall be met when the brakes are adjusted as closely as possible.
- 2.5. The pressure in the compression chamber beyond which the springs begin to actuate the brakes, with the latter adjusted as closely as possible, shall not be greater than 80 % of the minimum level (pm) of the normal available pressure.
- 2.6. When the pressure in the compression chamber falls to the level at which the brake parts begin to move, an optical or audible warning device shall be actuated. Provided this requirement is met, the warning device may be that specified in item 4.2.9. of Annex I.

- 2.7. On tractors fitted with spring brakes and authorized to draw trailers with continuous or semi-continuous brakes automatic application of the spring brakes shall cause the trailer brakes to be applied.

3. RELEASE SYSTEM

- 3.1. Spring brakes shall be so designed that, in the event of failure, it is possible to release them without using their normal control. This may be achieved by the use of an auxiliary device (pneumatic, mechanical, etc.).
- 3.2. If the operation of the auxiliary device referred to in item 3.1. above requires the use of a tool or spanner, the tool or spanner shall be kept on the tractor.

ANNEX IV

PARKING BRAKING BY MECHANICAL LOCKING OF THE BRAKE CYLINDERS

(LOCK ACTUATORS)

1. DEFINITION

"Mechanical locking of the brake cylinders" means a device for ensuring parking braking by mechanical wedging of the brake piston rod.

Mechanical locking occurs when the locking chamber is emptied of compressed air; the mechanical locking device shall be designed in such a way that it can be released when the locking chamber is again subjected to pressure.

2. SPECIAL REQUIREMENTS

- 2.1. When the pressure in the locking chamber approaches the level corresponding to mechanical locking, an optical or audible warning system shall be actuated.
- 2.2. In the case of brake actuators fitted with a mechanical locking device, the brake actuator shall be capable of being actuated by either of two energy reserves.
- 2.3. The locked brake cylinder may only be released if it is certain that the brake can be operated again after such release.
- 2.4. In the event of a failure of the source of energy supplying the locking chamber, an auxiliary unlocking device (mechanical or pneumatic, for instance) using, for example, the air in one of the tyres of the tractor shall be provided.

ANNEX V

ANNEX TO THE EEC TYPE-APPROVAL CERTIFICATE FOR A TYPE OF WHEELED AGRICULTURAL OR FORESTRY TRACTOR WITH REGARD TO ITS BRAKING DEVICES

(Article 4 (2) and article 10 of the Council Directive of 4 March 1974 on the approximation of the laws of the Member States relating to the type-approval of wheeled agricultural or forestry tractors, having a maximum design speed between 6 and 25 km/h)

Name of administration

- EEC Type Approval N°
- 1. Make (name of undertaking)
- 2. Type and commercial description
- 3. Name and address of manufacturer
- 4. Name and address of manufacturer's authorized representative (if any)
- 5. Unladen weight of tractor
- 6. Distribution of unladen weight between the axles (kg)
- 7. Maximum weight of the tractor
- 8. Distribution of the maximum weight of the tractor on each axle as referred to in item 1.2.1.3.1 of annex II
- 9. Make and type of brake linings
- 10. Engine type
- 11. Overall transmission ratio corresponding to maximum speed
- 12. Tyre dimensions :
- 12.1. Largest dimensioned tyres (braked axles).....
- 12.2. Tyres supporting the greatest technically admissible weight (non-braked axle)
- 13. Maximum speed of the tractor
- 14. Number and arrangement of braked axles

22

Annex V

- 15. Brief description of the braking device
- 16. Weight of tractor at the time of testing

	Unladen	Laden
Axle 1		
Axle 2		
Tyres dimensions		

- 17. Result of the test :

	Test speed km/h	Measured performance	Measured force applied to the control (kg)
17.1 Type 0 test			
Service braking			
Unladen
Laden
17.2. Type I test

- 18. Tractor submitted for EEC type-approval on
- 19. Technical service conducting type-approval tests
- 20. Date of the report issued by that service
- 21. Number of the report issued by that service
- 22. The EEC type-approval with regard to braking devices is granted/refused (+)
- 23. Place
- 24. Date
- 25. Signature
- 26. The document listed is items 2.2.1 to 2.2.3. of Annex I are annexed to this communication.

(+) Delete as appropriate.

PROPOSAL FOR A COUNCIL
DIRECTIVE ON THE APPROXIMATION OF THE LAWS
OF MEMBER STATES RELATING TO THE INSTALLATION OF
LIGHTING AND LIGHT SIGNALLING DEVICES ON WHEELED AGRI-
CULTURAL OR FORESTRY TRACTORS

EXPLANATORY MEMORANDUMI. GENERAL REMARKS

1. The Community type-approval procedure for wheeled agricultural or forestry tractors, which was the subject of the Council Directive of 4 March 1974 (1) also includes the heading of lighting and light-signalling devices.
2. On 23 July 1968 the Commission forwarded to the Council a proposal for a Directive on certain components and characteristics of wheeled agricultural tractors (2) which, under title XVI, made provision for regulations on the installation of lighting and light-signalling devices on tractors. The Council was unable to initiate an examination of this proposal as quickly as desired, primarily because of the difficulties encountered in the adoption of the Directive on type approval. The Commission found that, owing to the passage of time since its proposal was put forward, it was necessary to update that proposal in order to take account of developments since 1968.
3. The appropriate departments of the Commission accordingly set about this task with the assistance of experts on agricultural tractors and machinery. The amendments to the initial proposal, due partly to technical progress and partly to the outcome of parallel discussions in other international institutions, were so extensive that the Commission felt it was advisable to put forward a new proposal for a Directive.

Therefore the proposal for a Directive on "Lighting systems for agricultural tractors", which is scheduled to be put forward on 31 December 1974, has been included in the timetable for the forwarding of draft Directives by the Commission to the Council which is appended to the Council Resolution on industrial policy (3) of 17 December 1973.

(1) O.J. N° L 84, 28 March 1974, p.10.
(2) O.J. N° C 125, 28 November 1968.
(3) O.J. N° C 117, 31 December 1973, p.1.

This proposal only concerns the requirements for the installation of lighting and light-signalling devices on tractors; other proposals for Directives will be drafted for the design specifications of the various mandatory and optional lighting devices listed in this Directive.

II. SPECIFIC COMMENTS ON THE PROPOSED DIRECTIVE

The Directive applies to wheeled agricultural or forestry tractors having a maximum design speed of 6-25 km/h as also provided for in the Directive on type approval (Article 1).

Article 2 incorporates in the EEC type-approval procedure the requirements for the installation of mandatory or optional lighting and light-signalling devices as listed under 1.5.7. - 1.5.21. of Annex I.

Since certain new Member States at present do not carry out national type approval it is necessary to draft provisions enabling tractors complying with the requirements of the Directive (Article 3) to be used in those States.

Article 4 reflects a concern for safety; it provides that changes made to certain components or characteristics of a tractor type may necessitate a new inspection and, where necessary, a new vehicle report. The authority granting type approval is to assess whether these changes, as notified by the manufacturer, necessitate a new inspection or not, and consequently a new vehicle report. Annex I gives a list of the components or particulars which affect the installation of lighting and light-signalling devices.

Article 5 provides for the adaptation of the Directive to technical progress : the procedure is set out in Article 13 of the Council Directive of 4 March 1974 relating to the type approval of wheeled agricultural or forestry tractors.

Article 6 sets two time limits. Before the first time limit the Member States must have adopted and published the necessary measures to comply with the Directive. The second time limit is the date on which all the Member States must simultaneously enforce the common rules (Article 6, par. 1).

Finally the Commission must be notified within a reasonable space of time of all draft provisions drawn up by the Member States in the field covered by the Directive, in order to enable the Commission to comment thereon, if necessary (Article 6, par. 2).

The technical Annexes comprise several definitions, the procedure for applying for EEC type approval, general and particular specifications for the installation of the various lighting and light-signalling devices on the tractor, and the model approval certificate by means of which the authority granting or refusing type approval in respect of the installation of the lighting and light-signalling devices provides information additional to the sheet provided for in the Directive on type approval.

Broad agreement was reached between the experts from the Member States assisting the appropriate departments of the Commission in the drafting of the proposals for Directives on agricultural tractors and machinery. However, some points have not been settled, namely :

1. The choice between the two colours, i.e. white and selective yellow, proposed for main and dipped-beam headlights has been left to the user. The French experts expressed a strong reservation regarding the fact that the choice of colour was left to the user. They considered that the importing State should have the choice and should be free to allow both colours or to prohibit one of them.

France is the only Community country which lays down selective yellow as the colour for main-beam headlights (mandatory in this proposal) and dipped-beam headlights (optional in this proposal).

In view of the fact that neither of the colours has a distinct advantage over the other, as white gives greater visibility but is more liable to dazzle the drivers of oncoming vehicles, and selective yellow create less dazzle but reduce the driver's visibility, the Commission decided to propose that both colours should be authorized and that the choice should be left to the user.

2. The Danish experts expressed reservations regarding the restriction on installing direction indicators in accordance with scheme D on tractors not exceeding 6 metres in length, only, and also regarding certain of the angles of visibility envisaged for such devices. The Commission did not consider it appropriate to lay down, in respect of agricultural tractors, requirements which it has nevertheless adopted for motor vehicles (1).
3. The Danish experts also expressed a reservation regarding the possibility of installing only one parking light on each side of the tractor, regardless of its length. They felt that this installation arrangement ought only to be authorized for tractors less than 6 metres in length.

In this instance, too, the Commission was not able to agree with the arguments advanced, and in any case this proposal is on this point identical to that on motor vehicles.

4. There was complete disagreement on the installed height of the rear non-triangular red reflectors. The Commission's proposal represents a compromise.

III. CONSULTATION OF THE EUROPEAN PARLIAMENT AND THE ECONOMIC AND SOCIAL COMMITTEE

The Opinion of these two institutions is required under Article 100, al.2.

(1) COM (73) 2024.

THE COUNCIL OF THE EUROPEAN COMMUNITIES,

Having regard to the treaty establishing the European Economic Community, and in particular Article 100 thereof,

Having regard to the proposal from the Commission,

Having regard to the Opinion of the European Parliament,

Having regard to the Opinion of the Economic and Social Committee,

Whereas the technical requirements which tractors must comply pursuant to national laws relate, inter alia, to the installation of lighting and light signalling devices;

Whereas these requirements differ from one Member State to another; whereas it is therefore necessary that all Member States adopt the same requirements either in addition to or in place of their existing rules, in order, in particular, to allow the EEC type-approval procedure which was the subject of the Council Directive of 4 March 1974 on the approximation of the laws of the Member States relating to the type-approval of wheeled agricultural or forestry tractors to be applied in respect of each type of tractor (*);

Whereas common requirements on the construction of lighting and light signalling devices will be the subject of further special directives;

Whereas the approximation of the laws of Member States relating to tractors includes mutual recognition of the inspections carried out by each of them on the basis of common provisions; whereas if such a system is to function successfully, these provisions must be applied by all Member States from the same date;

./.

(*) O.J., N° L 84, 28 March 1974, p. 10.

HAS ADOPTED THIS DIRECTIVE :

Article 1

1. "Agricultural or forestry tractor" means any motor vehicle, fitted with wheels or caterpillar tracks and having at least two axles, the main function of which is specially designed to tow, push, carry or power certain tools, machinery or trailers intended for agricultural or forestry use. It may be equipped to carry a load and passengers.

2. This Directive shall apply only to tractors defined in the preceding paragraph which are fitted with pneumatic tyres and which have two axles and a maximum design speed between 6 and 25 km/h.

Article 2

No Member State may refuse to grant EEC type-approval or national type-approval of a tractor on grounds relating to the installation of lighting and light signalling devices, whether mandatory or optional, listed under items 1.5.7. - 1.5.21. in Annex I if these are installed in accordance with the specifications contained in Annex I to this Directive.

Article 3

No Member State may refuse the registration or prohibit the sale, entry into service or use of tractors on grounds relating to the installation of lighting and light signalling devices, whether mandatory or optional, listed under items 1.5.7. - 1.5.21. in Annex I if these are installed in accordance with the specifications contained in Annex I to this Directive.

./.

Article 4

The Member State which has granted EEC type-approval must take the necessary measures to ensure that it is informed of any modification of a component or characteristic referred to in Annex I (1.1).

The competent authorities within this State shall assess whether the modified type of tractor should be subjected to a further set of tests, accompanied by a fresh information document. If it emerges from the tests that the specifications of this Directive have not been met, the modification shall not be authorized.

Article 5

The amendments necessary for adapting to technical progress the requirements of the Annexes shall be adopted in accordance with the procedure laid down in Article 13 of the Council Directive of 4 March 1974 on the approximation of the laws of the Member States relating to the type-approval of wheeled agricultural or forestry tractors.

Article 6

1. The Member States shall adopt and publish the provisions needed in order to comply with this Directive before 1 April 1976 and shall forthwith inform the Commission thereof.

They shall apply these provisions from 1 October 1976.

2. As soon as this Directive has been notified, the Member States shall take care to inform the Commission, in sufficient time to enable it to submit its comments, of any draft laws, regulations or administrative provisions which they intend to adopt in the field covered by the Directive.

Article 7

This Directive is addressed to the Member States.

ANNEX I

INSTALLATION OF LIGHTING AND LIGHT-SIGNALLING

DEVICES

1. DEFINITIONS

For the purposes of this Directive :

1.1. "Tractor type with regard to the installation of lighting and light signalling devices" means tractors which do not differ in such essential respects as :

1.1.1. the dimensions and exterior lines of the tractor,

1.1.2. the number and siting of the devices,

1.1.3. the following are likewise not considered to be "tractors of a different type"

1.1.3.1. tractors which differ within the meaning of items 1.1.1. and 1.1.2. above but not in such a way as to entail a change in the kind, number, siting and geometric visibility of the lights laid down for the tractor type in question;

1.1.3.2. tractorson which optional lights are fitted or are absent.

1.2. "Transverse plane" means a vertical plane perpendicular to the median longitudinal plane of the tractor.

1.3. "Unladen tractor" means the tractor in running order, as defined under Item 2.4. of Annex I, model for information document, to the Council Directive of 4 March 1974 on the type approval of wheeled agricultural or forestry tractors, but without a driver.

1.4. "Laden tractor" means the tractor loaded to its maximum technically permissible weight, as stated by the manufacturer, who shall also fix its distribution among the axles.

1.5. "Light" means a device designed to illuminate the road (headlamp) or to emit a luminous signal. Rear registration plate illuminating devices and reflex reflectors shall likewise be regarded as lights.

1.5.1. "Equivalent lights" means lights having the same function and authorized in the country in which the tractor is registered; such lights may have different characteristics from those fitted on the tractor when it is approved on condition that they satisfy the requirements of this annex.

1.5.2. "Independent lights" means lights having separate illuminating surfaces, separate light sources, and separate lamp bodies.

1.5.3. "Grouped lights" means devices having separate illuminating surfaces and separate light sources, but a common lamp body.

Annex I

- 1.5.4. "Combined lights" means devices having separate illuminating surfaces, but a common light source and a common lamp body.
- 1.5.5. "Reciprocally incorporated lights" means devices having separate light sources (or a single light source operating under different conditions), totally or partially common illuminating surfaces and a common lamp body.
- 1.5.6. "Concealable illuminating light" means a headlamp capable of being partly or completely hidden when not in use. This result may be achieved by means of a movable cover, by displacement of the headlamp, or by any other suitable means.
- 1.5.7. "Driving light" means the light used to illuminate the road over a long distance ahead of the tractor.
- 1.5.8. "Passing light" means the light used to illuminate the road ahead of the tractor without causing undue dazzle or discomfort to on-coming drivers and other road-users.
- 1.5.9. "Fog light" means the light used to improve the illumination of the road in case of fog, snow fall, rainstorms, or dust clouds.
- 1.5.10. "Reversing light" means the light used to illuminate the road to the rear of the tractor and to warn other road-users that the tractors is reversing or about to reverse.
- 1.5.11. "Direction indicator light" means the light used to indicate to other road-users that the driver intends to change direction to the right or to the left.
- 1.5.12. "Hazard warning signal" means the simultaneous operation of all of a tractor's direction indicator lights to draw attention to the fact that the tractor temporarily constitutes a special danger to other road-users.
- 1.5.13. "Stop light" means the light used to indicate to other road-users to the rear of the tractor that the latter's driver is applying the service brake.
- 1.5.14. "Rear registration plate illuminating device" means the device used to illuminate the space intended to accommodate the rear registration plate; it may consist of different optical elements.
- 1.5.15. "Front position" means the light used to indicate the presence and the width of the tractor when the latter is viewed from the front.
- 1.5.16. "Rear position light" means the light used to indicate the presence and the width of the tractor when the latter is viewed from the rear.

Annex I

- 1.5.17. "Rear fog light" means the light used to render the tractor more readily visible from the rear in dense fog.
- 1.5.18. "Parking light" means the light used to draw attention to the presence of a stationary tractor, without a trailer, in a built-up area. In such circumstances it replaces the position lights.
- 1.5.19. "End-outline marker light" means the light fitted to the extreme outer edges and as close as possible to the top of the tractor and intended clearly to indicate the tractor's overall width. This signal is intended, for certain tractors, to complement the tractor's position lights by drawing particular attention to its bulk.
- 1.5.20. "Reflex reflector" means a device used to indicate the presence of a tractor by the reflection of light emanating from a light source unconnected with the tractor, the observer being situated near the source.
- 1.5.21. "Work light" means a device intended to illuminate a working area or process.
- 1.6. "Illuminating surface of a light"
- 1.6.1. "Illuminating surface of a headlight" (items 1.5.7. - 1.5.10.) means the orthogonal projection of the full aperture of the reflector in a transverse plane. If the headlamp glass (or glasses) extend over a part only of full aperture of the reflector, then the projection of that part only is taken into account.
- 1.6.2. "Illuminating surface of a signalling light other than a reflex reflector" (items 1.5.11. - 1.5.19.) means the orthogonal projection of the light in a plane perpendicular to its axis of reference and in contact with the exterior emitting surface of a light, this projection being bounded by the edges of screens situated on this plane, each allowing only 98 % of the total luminous intensity of the light to persist in the direction of the axis of reference. To determine the lower, upper and lateral limits of the light, only screens with horizontal or vertical edges are used.
- 1.6.3. "Illuminating surface of a reflex reflector" (item 1.5.20.) The illuminating surface of a reflex reflector in a plane perpendicular to its axis of reference is bounded by planes touching the outer edges of the light projection of the reflex reflector and parallel to this axis. To determine the lower, upper and lateral limits of the lights, only vertical and horizontal planes are considered.
- 1.6.4. "Outer light-emitting surface" for a defined direction of observation, means the orthogonal projection of the surface of light emission in a plane perpendicular to the direction of observation (see drawing in appendix 1).

- 34
- 1.7. "Axis of reference" means the characteristic axis of the light signal, determined by the manufacturer for use as the direction of reference ($H = 0^\circ$, $V = 0^\circ$) for photometric measurements and when fitting the light on the tractor.
- 1.8. "Centre of reference" means the intersection of the axis of reference with the light-emitting surface, specified by the manufacturer of the light.
- 1.9. "Angles of geometric visibility" means the angles which determine the field of the minimum solid angle in which the outer light-emitting surface of the light must be visible. That field of the solid angle is determined by the segments of a sphere of which the centre coincides with the centre of reference of the light and the equator is parallel with the ground. These segments are determined in relation to the axis of reference. The horizontal angles β correspond to the longitude and the vertical angles α to the latitude. There must be no obstacle on the inside of the angles of geometric visibility to the propagation of light from any part of the outer light-emitting surface of the light. This does not apply to any obstacles existing at the time when the light was approved if approval was required.
- 1.10 "Extreme outer edge" on either side of the tractor means the plane parallel to the median longitudinal plane of the tractor and coinciding with the latter's lateral outer edge, disregarding any projection(s) such as :
- 1.10.1. tyres near their point of contact with the ground, and of connections for tyre-pressure gauges,
- 1.10.2. any anti-skid devices which may be mounted on the wheels,
- 1.10.3. rear-view mirrors,
- 1.10.4. side direction indicators, end-outline marker lights, position lights and parking lights,
- 1.10.5. customs seals affixed to the tractor, and devices for securing and protecting such seals.
- 1.11. "Overall width" means the distance between the two vertical planes defined under item 1.10. above.
- 1.12. The following shall be considered to be :
- 1.12.1. "a single light" : any combination of two or more lights, whether identical or not, having the same function and colour, if it comprises devices, the projection of whose aggregate light-emitting surfaces in a given transverse plane occupies 60 % or more of the area of the smallest rectangle circumscribing the projections of those light-emitting surfaces, provided that such combination is, where approval is required, approved as a single light. This possible combination does not apply to driving lights, passing lights and fog lights;

Annex I

- 1.12.2. "two lights" or "an even number of lights" : a single light-emitting surface in the shape of a band if placed symmetrically in relation to the median longitudinal plane of the tractor and extending on both sides to within not less than 0.40 m of the extreme outer edge of the tractor, if not less than 0.80 m long. The illumination of such a surface shall be provided by not less than two light sources placed as close as possible to its ends. The light-emitting surface may be constituted by a number of juxtaposed elements on condition that the projections of the several individual light-emitting surfaces in the same transverse plan occupy not less than 60 % of the area of the smallest rectangle circumscribing the projections of those individual light-emitting surfaces.
- 1.13. "Distance between two lights" which face in the same direction, means the distance between the orthogonal projections in a plane perpendicular to the direction in question of the outlines of two illuminating surfaces defined under item 1.6. With a passing light, the illuminating surface is limited on the side where the lines cross by the imaginary projection of the line on to the glass. If the reflector and glass are adjustable, the normal adjustment should be used.
- 1.14. "Optional" means a light the presence of which is left to the discretion of the manufacturer.
- 1.15. "Operational warning light" means a light showing whether a device has been actuated and is operating correctly.
- 1.16. "Circuit-closed warning light" means a light showing that a device has been actuated without showing whether it is operating correctly.

2. APPLICATION FOR EEC TYPE-APPROVAL

- 2.1. The application for EEC type-approval of a tractor type with regard to the installation of lighting and light-signalling devices shall be submitted by the tractor manufacturer or his representative.
- 2.2. It shall be accompanied by the following document in triplicate, and by the following particulars :
 - 2.2.1. a description of the tractor type with regard to the requirements listed under items 1.1.1. - 1.1.3. above;
 - 2.2.2. a list of the lights fitted by the manufacturer in order to form the lighting and light signalling equipment. Each type shall be duly identified (in particular, approval mark, name and address of manufacturer etc.); equivalent lights may subsequently be added without a new type approval being required;

- 2.2.3. layout drawing of the lighting and light-signalling equipment as a whole, showing the position of the various lights on the tractor;
- 2.2.4. layout drawing(s) for each individual light showing the illuminating surfaces as defined under item 1.6.
- 2.3. An unladen tractor fitted with lighting and signalling equipment as described under item 2.2.2. and representative of the tractor type to be approved must be submitted to the technical authority conducting approval tests.
- 2.4. The document provided for in annex II shall be attached to the type approval document.

3. GENERAL SPECIFICATIONS

- 3.1. The lighting and light-signalling devices shall be so fitted that in normal conditions of use, and notwithstanding the vibrations to which they may be subjected, they retain the characteristics laid down in this annex and enable the tractor to comply with the requirements of this annex. In particular, it shall not be possible for the adjustment of the lights to be inadvertently disturbed.
- 3.1.1. Tractors shall be equipped with electrical connectors to enable a detachable light-signalling system to be brought into use whenever their rearward light-signalling devices are obscured. In particular the tractor shall be fitted with the permanently connected socket outlet recommended in standards ISO R 1724 (Electrical connections for vehicles with 6 or 12 volt electrical systems applying more specifically to private motor cars and lightweight trailers or caravans) (first edition - April 1970) and ISO R 1185 (Electrical connections between towing and towed vehicles having 24 volt electrical systems used for international commercial transport purposes) (first edition-March 1970). In the case of standard ISO R 1185, the function of contact ? is restricted to the left rear position light and to the left end-outline marker light.
- 3.2. The illuminating lights prescribed under items 1.5.7., 1.5.8. and 1.5.9. shall be so fitted that a correct setting of their alignment can easily be performed.
- 3.3. For all light signalling devices, including those mounted on the side panels, the reference axis of the light when fitted on the tractor shall be parallel to the bearing plane of the tractor on the road; in addition, it shall be perpendicular to the median

longitudinal plane of the tractor in the case of side reflex reflectors and parallel to that plane in the case of all other signalling devices. In each direction a tolerance of $\pm 3^{\circ}$ shall be allowed. In addition, if specific instructions as regards fitting are laid down by the manufacturer they shall be abided by.

- 3.4. In the absence of specific instructions, the height and alignment of the lights shall be checked with the tractor unladen and placed on a flat, horizontal surface.
- 3.5. In the absence of specific instructions, lights constituting a pair shall:
 - 3.5.1. be fitted symmetrically in relation to the median longitudinal plane,
 - 3.5.2. be symmetrically in relation to the median longitudinal plane,
 - 3.5.3. satisfy the same colorimetric requirements,
 - 3.5.4. have substantially identical photometric characteristics.
- 3.6. On tractors the external lines of which are asymmetrical, the above requirements shall be satisfied as far as possible. The requirements of items 3.5.1. and 3.5.2. shall be regarded as having been met if the distances of the two lights from the median longitudinal plane are equal.
- 3.7. Lights having different functions may be independent or be grouped, combined or incorporated in one device, on condition that each of such light complies with the requirements applicable to it.
- 3.8. The maximum height above ground shall be measured from the highest point and the minimum height from the lowest point of the illuminating surface.
- 3.9. In the absence of specific instructions, no lights other than direction-indicator lights and the hazard warning lights shall be flashing lights. No red light shall be visible towards the front and no white light other than the reversing light or work lights shall be visible towards the rear.
- 3.10. This requirement is considered to have been met if:
 - 3.10.1. For the visibility of a red light towards the front: there must be no direct visibility of a red light if viewed by an observer moving within zone 1 of a transverse plane situated 25 m in front of the tractor (see drawing in appendix 2, figure 1)

- 3.10.2. For the visibility of a white light towards the rear : there must be no direct visibility of a white light if viewed by an observer moving within zone 2 in a transverse plane situated 25 m behind the tractor (see drawing in appendix 2, figure 2).
- 3.10.3. Zones 1 and 2, as seen by the observer, are limited in their respective planes as follows :
- 3.10.3.1. As regards height, by two horizontal planes which are, respectively, 1 and 2.20 m above the ground,
- 3.10.3.2. As regards width, by two vertical planes towards the front and rear respectively, which make an angle of 15° outside the tractor by reference to its median plane, pass through the point (or points) of contacts of vertical planes which are parallel to the median plane of the tractor, and limit the overall width of the tractor.
If there are several points of contact, the one which is furthest towards the front shall correspond to the front plane and the one furthest towards the rear shall correspond to the rear plane.
- 3.11. The electrical connections shall be such that the front position lights, the rear position lights, the end-outline marker lights if they exist and the rear-registration-plate illuminating device can be switched on only simultaneously.
- 3.12. The electrical connections shall be such that the driving lights, passing lights, and fog lights cannot be switched on unless the lights referred to under item 3.11. above are also switched on. This requirements shall not apply, however, to driving lights or passing lights when their illuminated warnings consist of the intermittent lighting up at short intervals of the passing lights or in the intermittent lighting up of the driving lights or in the alternate lighting up at short intervals of the passing lights and driving lights.
- 3.13. The colours of the lights referred to in this annex are as follows :
- | | | |
|--|---|--|
| .driving light | : | white or selective yellow, |
| .passing light | : | white or selective yellow, |
| .fog light | : | white or selective yellow, |
| .reversing light | : | white, |
| .direction-indicator light | : | amber, |
| .hazard-warning light signal | : | amber, |
| .stop light | : | red, |
| .rear registration plate illuminating device | : | white, |
| .front position light | : | white; selective yellow if the side light is incorporated in a selective yellow headlamp, |
| .rear position light | : | red, |
| .rear fog-light | : | red, |
| .parking light | : | white in front, red behind, amber if they are incorporated in the side direction-indicator lights, |
| .work light | : | no specification. |

Annex I

.end-outline marker light : white in front, red behind,
.rear-reflex-reflector, non-
triangular : red.

3.14. The function of the circuit-closed warning light indicators may be fulfilled by the operational warning light indicators.

3.15. Concealable lights

3.15.1. Tractor lighting and light signalling devices, with the exception of the direction indicator lights, may be designed so that it is possible to conceal them when not in use.

3.15.2. Once having been placed in its working position, a lamp shall continue to stay there.

3.15.3. A right-hand concealable light shall be at all times in the same position as its left-hand counterpart, and vice-versa.

4. INDIVIDUAL SPECIFICATIONS

4.1. Driving light

4.1.1. Presence
Optional.

4.1.2. Number
2 or 4.

4.1.3. Arrangement
No particular specifications.

4.1.4. Position

4.1.4.1. Width :

The outer edges of the illuminating surface shall in no case be closer to the extreme outer edge of the tractor than the outer edges of the illuminating surface of the passing lights.

4.1.4.2. Height :

No individual specification.

4.1.4.3. Length :

At the front of the tractor; this requirement shall be considered to be satisfied if the light emitted does not cause discomfort to the driver either directly, or indirectly through the rear-view mirrors and/or other reflecting surfaces of the tractor.

- 4.1.5. Geometric visibility
The visibility of the illuminating surface, including its visibility in areas which do not appear to be illuminated in the direction of observation considered, shall be ensured within a divergent space defined by generating lines based on the perimeter of the illuminating surface and forming an angle of not less than 5° with the axis of reference of the headlight.
- 4.1.6. Alignment
Towards the front.
Apart from the devices necessary to maintain correct adjustment, and when there are two pairs of driving lights, one pair, consisting of headlights functioning as driving lights only, may swivel, according to the angle of lock of the steering, about an approximately vertical axis.
- 4.1.7. May be "grouped"
with the passing light and the other front lights.
- 4.1.8. May not be "combined"
with any other light.
- 4.1.9. May be "reciprocally incorporated"
- 4.1.9.1. with the passing light if the driving light does not swivel according to the angle of lock of the steering;
- 4.1.9.2. with the front position lights;
- 4.1.9.3. with the fog lights.
- 4.1.10. Electrical connections
- 4.1.10.1. The driving lights may be switched on either simultaneously or in pairs. For changing over from the passing to the driving beam at least one pair of driving beams must be switched on. For changing over from the driving to the passing beam all driving beams must be switched off simultaneously.
- 4.1.10.2. The passing lights may remain switched on at the same time as the driving lights.
- 4.1.11. Circuit-closed warning light
Mandatory.
- 4.1.12. Other requirements
- 4.1.12.1. The aggregate maximum intensity of the driving beams which can be switched on simultaneously shall not exceed 225,000 cd.

Annex I

- 4.1.12.2. This maximum intensity shall be obtained by adding together the individual maximum intensities measured at the time of type-approval and shown on the relevant approval forms.
- 4.2. Passing light
- 4.2.1. Presence
Mandatory.
- 4.2.2. Number
2.
- 4.2.3. Arrangement
No individual specifications.
- 4.2.4. Position
- 4.2.4.1. Width:
No specification.
- 4.2.4.2. Height:
Above the ground : minimum 500 mm, maximum 1,200 mm. This value may, however, be raised to 1.500 mm if the tractor structure or its working equipment render this necessary.
- 4.2.4.3. Length:
At the front of the tractor; this requirement shall be considered to be satisfied if the light emitted does not cause discomfort to the driver either directly, or indirectly through the rear-view mirrors and/or other reflecting surfaces of the tractor.
- 4.2.5. Geometric visibility
Defined by angles α and β as specified in item 1.9.
 α = 15° upwards and 10° downwards
 β = 45° outwards and 5° inwards.
 Within this field, almost the whole of the light-emitting surface of the light shall be visible.
 The presence of panels or other items of equipment near the light shall not give rise to secondary effects causing discomfort to other road users.
- 4.2.6. Alignment
- 4.2.6.1. The alignment of the passing lights shall not vary according to the angle of lock of the steering.
- 4.2.6.2. If the height of the passing lights is 500 - 1.200 mm it shall be possible to lower the passing beam by 0.5 - 4 % ;

42

- 4.2.6.3. When the height of the passing lights is 1.200 - 1.500 mm the limit of 4% envisaged under item 4.2.6.2. above shall be increased to a maximum of 5 %.
- 4.2.7. May be "grouped"
with the driving lights and the other front lights.
- 4.2.8. May not be "combined"
with any other light.
- 4.2.9. May be "reciprocally incorporated"
 - 4.2.9.1. with the driving light, unless the latter swivels according to the angle of lock of the steering;
 - 4.2.9.2. with the other front lights.
- 4.2.10. Electrical connections
The control for changing over to the passing light shall switch off all driving lights simultaneously. The passing lights may remain switched on at the same time as the driving lights.
- 4.2.11. Circuit-closed warning light
Optional.
- 4.2.12. Other requirements
The provisions of item 3.5.2. shall not apply to passing lights.
- 4.3. Fog lights
 - 4.3.1. Presence
Optional.
 - 4.3.2. Number
2.
 - 4.3.3. Arrangement
No individual specifications.
 - 4.3.4. Position
 - 4.3.4.1. Width:
No specification.
 - 4.3.4.2. Height:
250 mm minimum above the ground. No point on the illuminating surface shall be higher than the highest point on the illuminating surface of the passing light.

./.

- 4.3.4.3. Length:
At the front of the tractor; this requirement shall be considered to be satisfied if the light emitted does not cause discomfort to the driver either directly, or indirectly through the rear-view mirrors and/or other reflecting surfaces of the tractor.
- 4.3.5. Geometric visibility
Defined by angles α and β as specified in item 1.9.
 α = 5° upwards and downwards,
 β = 45° outwards and 5° inwards.
- 4.3.6. Alignment
The alignment of the fog lights shall not vary according to the angle of lock of the steering.
They shall be directed forwards without dazzling or causing undue discomfort to drivers travelling in the opposite direction or to other road users.
- 4.3.7. May be "grouped"
with other front lights.
- 4.3.8. May not be "combined"
with other front lights.
- 4.3.9. May be "reciprocally incorporated"
 - 4.3.9.1. with driving lights which do not vary according to the angle of lock of the steering , when there are four driving lights;
 - 4.3.9.2. with the front position lights.
- 4.3.10. Electrical connections
It should be possible to switch the fog lights on and off independently of the driving or passing lights and vice-versa.
- 4.3.11. Circuit closed warning light
Optional.
- 4.4. Reversing lights
 - 4.4.1. Presence
Optional.
 - 4.4.2. Number
1 or 2
 - 4.4.3. Arrangement
No individual specifications.

4.4.4. Position

4.4.4.1. Width:
No individual specifications.

4.4.4.2. Height:
250 mm minimum and 1,200 mm maximum above the ground.

4.4.4.3. Length:
At the back of the tractor.

4.4.5. Geometric visibility

Defined by angles α and β as specified in item 1.9.

α = 15° upwards and 5° downwards,

β = 45° to right and left if there is only one light,

β = 45° outwards and 30° inwards if there are two.

4.4.6. Alignment
Rearwards.

4.4.7. May be "grouped"
with any other rear light.

4.4.8. May not be "combined"
with other lights.

4.4.9. May not be "reciprocally incorporated"
with other lights.

4.4.10. Electrical connections

It can only light up if the reverse gear is engaged and if the device which controls the starting or stopping of the engine is in such a position that operation of the engine is possible. It shall not light up or remain lit up if one of the above conditions is not satisfied.

4.4.11. Warning light
Prohibited.

4.5. Direction indicator light

4.5.1. Presence

Mandatory on all tractors. Indicator types shall fall into categories (1-5) the assembly of which on one tractor constitutes an "arrangement" (A-E).

Arrangements A shall only be allowed on tractors whose overall length does not exceed 4.60 m on condition that the distance between the outer edges of the illuminating surfaces is not greater than 1,60 m.

Arrangements B, C, E shall apply to all tractors.

Arrangement D shall only be allowed on tractors whereby the distance between the illuminating surfaces of the front and rear direction indicators is not greater than 6 m.

4.5.2. Number

The number of devices shall be such that they can give signals which correspond to one of the arrangements referred to under the following item.

4.5.3. Arrangement (see appendix 3)

- A - 2 side indicators (category 3)
- B - 2 front side indicators (category 4)
- 2 rear indicators (category 2)
- C - 2 front indicators (category 1)
- 2 rear indicators (category 2)
- 2 repeating side indicators (category 5)
- D - 2 front indicators (category 1)
- 2 rear indicators (category 2)
- E - 2 front indicators (category 1)
- 2 rear indicators (category 2)

4.5.4. Position

4.5.4.1. Width:

The edge of the illuminating surface furthest from the median longitudinal plane of the tractor shall not be more than 400 mm from the outermost edge of the tractor.

The clearance between the inner edges of the two illuminating surfaces shall be not less than 500 mm.

Where the vertical distance between the rear direction indicator light and the corresponding rear position light is not more than 300 mm, the distance between the extreme outer edge of the tractor and the outer edge of the rear direction indicator light shall not exceed by more than 50 mm the distance between the extreme outer edge of the tractor and the outer edge of the corresponding rear position light.

For front direction indicator lights, the illuminating surface shall be at a minimum of 40 mm from the illuminating surface of the passing lights or fog lights. A smaller clearance is permitted if the luminous intensity in the reference axis of the direction indicator light is equal to at least 400 cd.

- 4.5.4.2. Height:
Above the ground : 500 mm minimum for indicators of categories 3, 4 and 5.
400 mm minimum for indicators in categories 1 and 2.
1,900 mm maximum for all categories.
If the structure of the tractor makes it impossible to keep to this maximum figure, the highest point on the illuminating surface may be at 2,300 mm in the case of indicators of categories 3,4 and 5 and at 2,100 mm in the case of indicators of categories 1 and 2.
- 4.5.4.3. Length:
The distance between the centre of reference of the illuminating surface of the side indicator (arrangements B and C) and the transverse plane which marks the forward boundary of the tractor's overall length, shall not exceed 1,800 mm. If the structure of the tractor makes it impossible to keep to the minimum angles of visibility, this distance may be increased to 2,500 mm if the tractor is equipped in conformity with arrangement C.
- 4.5.5. Geometric visibility
Horizontal angles : See appendix 3 to this item.
Vertical angles : 15° above and below the horizontal.
The vertical angle below the horizontal may be reduced to 10° in the case of side indicators of arrangements B and C if their height is less than 1,500 mm.
- 4.5.6. Alignment
If individual specifications for fitting are laid down by the manufacturer they shall be observed.
- 4.5.7. May be "grouped"
with one or more lights.
- 4.5.8. May not be "combined"
with another light.
- 4.5.9. May not be "reciprocally incorporated"
with another light.
- 4.5.10. Electrical connections
Direction indicator lights shall switch on independently of the other lights.
All direction indicator lights on one side of a tractor shall be switched on and off by means of one control.

4.5.11. Operating warning light

Mandatory for all direction indicator lights not directly visible to the driver. It may be optical, or auditory, or both.

If it is optical it shall be a flashing light which, in the event of defective operation of any of the direction indicator lights other than repeating side direction indicator lights, is extinguished, remains alight without flashing, or shows a marked change of frequency. If it is entirely auditory it shall be easily audible and shall show a marked change of frequency under like circumstances.

4.5.12. Other requirements

The light shall be a flashing light flashing 90 ± 30 times per minute. Operation of the light-signal control shall be followed within not more than one second by the appearance of the light and within not more than one and a half seconds by the first extinction of the light. All the direction-indicator lights which are on the same side of a tractor shall flash in phase.

4.6. Hazard-warning signal

4.6.1. Presence
Mandatory.

4.6.2. Number

4.6.3. Arrangement

4.6.4. Position

4.6.4.1. Width

4.6.4.2. Height

4.6.4.3. Length

4.6.5. Geometric visibility

4.6.6. Alignment

4.6.7. May/may not be "grouped"

4.6.8. May/may not be "combined"

4.6.9. May/may not be "reciprocally incorporate"

as prescribed in the corresponding heading of item 4.5.

4.6.10. Electrical connections

This signal shall be given by means of a separate control enabling all the direction indicator lights to be supplied with current simultaneously.

4.6.11. Circuit-closed warning light

Mandatory. Flashing warning light, which can operate in conjunction with the warning light (or lights) laid down in item 4.5.

4.6.12. Other requirements

As laid down under the corresponding heading of item 4.5.

If a tractor is authorised to draw a trailer the hazard warning signal control shall be also capable of bring the trailer's direction indicators into action. The hazard warning signal shall be capable of functioning even if the device which starts up or switches off the engine is in a position which makes it impossible to start the engine.

4.7. Stop lights4.7.1. Presence
Optional.4.7.2. Number
24.7.3. Arrangement
No individual specifications.4.7.4. Position4.7.4.1. Width:
500 mm minimum apart. This distance apart may be reduced to 400 mm if the overall width of the tractor is less than 1,300 mm.4.7.4.2. Height:
above the ground; 400 mm minimum, 1,900 mm maximum, or 2,100 mm if the shape of the bodywork makes it impossible to keep within 1,900 mm.4.7.4.3. Length:
at rear of tractor.4.7.5. Geometric visibility

Horizontal angle : 45° outwards and inwards.

Vertical angle : 15° above and below the horizontal. The vertical angle below the horizontal may be reduced to 10° in the case of lights less than 1,500 mm above the ground.

- 4.7.6. Alignment
Towards the rear of the tractor.
- 4.7.7. May be "grouped"
with one or more other rear lights.
- 4.7.8. May not be "combined"
with another light.
- 4.7.9. May be "reciprocally incorporated"
with the rear position light.
- 4.7.10. Electrical connections
Shall light up when the service brake is applied.
- 4.7.11. Warning light
Optional.
- 4.7.12. Other requirements
The luminous intensity of the stop lights shall be markedly greater than that of the rear position lights.
- 4.8. Rear registration plate illuminating device
 - 4.8.1. Presence
Mandatory.
 - 4.8.2. Number
 - 4.8.3. Arrangement
 - 4.8.4. Position
 - 4.8.4.1. Width
 - 4.8.4.2. Height
 - 4.8.4.3. Length
 - 4.8.5. Geometric visibility
 - 4.8.6. Alignment
 - 4.8.7. May be "grouped"
with one or more rear lights.
 - 4.8.8. May be "combined"
with the rear position lights.
 - 4.8.9. May not be "reciprocally incorporated"
with any other light.
 - 4.8.10. Electrical connections
The device shall light up only at the same time as the rear position light.

Such that the device is able to illuminate the site of the registration plate.

50

- 4.8.11. Warning light
Optional.
- 4.9. Front position lights
 - 4.9.1. Presence
Mandatory.
 - 4.9.2. Number
2.
 - 4.9.3. Arrangement
No individual specifications.
 - 4.9.4. Position
 - 4.9.4.1. Width:
The point on the illuminating surface which is farthest from the tractor's median longitudinal plane shall not be more than 400 mm from the extreme outer edge of the tractor.
The clearance between the respective inner edges of the two illuminating surfaces shall not be less than 500 mm.
 - 4.9.4.2. Height:
Above the ground : minimum 400 mm , maximum 1,900 mm or, in exceptional cases, minimum 300 mm, maximum 2,100 mm where the shape of the bodywork makes it impossible to keep within the prescribed 400 to 1,900 mm.
 - 4.9.4.3. Length:
No specification provided that the laps are aligned forwards and form the angles of geometrical visibility mentioned below.
 - 4.9.5. Geometric visibility
 - Horizontal angle
For the two front position lights 10° inwards and 80° outwards. However, in special cases, the angle of 10° inward may be reduced to 5° if the shape of the bodywork makes it impossible to adhere to 10°.
 - Vertical angle
15° above and below the horizontal. The vertical angle below the horizontal may be reduced to 10° if the height of the light is less than 1,500 mm.
 - 4.9.6. Alignment
Towards the front.
 - 4.9.7. May be "grouped"
With any other front light.

./.

- 4.9.8. May not be "combined"
with any other lights.
- 4.9.9. May be "reciprocally incorporated"
with any other front lighting or light signalling device.
- 4.9.10. Electrical connections
No individual specifications.
- 4.9.11. Warning light
Mandatory. This warning light shall not be required if the instrument panel lighting can be turned on only simultaneously with the front position lights.
- 4.10. Rear-position lights
- 4.10.1. Presence
Mandatory.
- 4.10.2. Number
2.
- 4.10.3. Arrangement
No individual specifications.
- 4.10.4. Position
- 4.10.4.1. Width:
The point on the illuminating surface which is farthest from the tractor's median longitudinal plane shall be not more than 400 mm from the extreme outer edge of the tractor. The clearance between the respective inner edges of the two illuminating surfaces shall not be less than 500 mm.
- 4.10.4.2. Height:
Above the ground : 400 mm minimum and 1,900 mm maximum or 2,100 mm if the shape of the bodywork makes it impossible to keep to the 1,900 mm.
- 4.10.4.3. Length:
At rear of tractor.
- 4.10.5. Geometric visibility
Horizontal angle
for the two rear position lights :
 - a) either 45° inwards and 80° outwards,
 - b) or 80° inwards and 45° outwards.

Vertical angle

15° above and below the horizontal. The vertical angle below the horizontal may be reduced to 10° if the height of the light is less than 1,500 mm.

- 4.10.6. Alignment
Towards the rear.
- 4.10.7. May be "grouped"
with any other rear light.
- 4.10.8. May be "combined"
with the rear registration-plate illuminating device.
- 4.10.9. May be "reciprocally incorporated"
with the stop lights and the rear fog lights.
- 4.10.10. Electrical connections
No individual specifications.
- 4.10.11. Circuit-closed warning light.
It shall be merged with that of the front position lights.
- 4.11. Rear fog light
- 4.11.1. Presence
Optional.
- 4.11.2. Number
1 or 2.
- 4.11.3. Arrangement
Such as to satisfy the conditions of geometric visibility.
- 4.11.4. Position
- 4.11.4.1. Width:
If there is only one rear fog light, it shall be on the side of the median longitudinal plane of the tractor which is opposite to the direction of traffic prescribed in the country of registration. In all cases the distance between the rear fog light and the stop light shall be greater than 100 mm.
- 4.11.4.2. Height:
Between 250 mm and 1000 mm above the ground.
- 4.11.4.3. Length:
At rear of tractor.

- 4.11.5. Geometric visibility
Horizontal angle : 25° inwards and outwards.
Vertical angle : 5° above and below the horizontal.
- 4.11.6. Alignment
Towards the rear.
- 4.11.7. May be "grouped"
with any other rear lights.
- 4.11.8. May not be "combined"
with other lights.
- 4.11.9. May be "reciprocally incorporated"
with rear position lights.
- 4.11.10. Electrical connections
Shall be such that the rear fog light can light up only when the passing lights or the fog lights are in use. If there are fog lights, it shall be possible to extinguish the rear fog light independently of the fog lights.
- 4.11.11. Circuit-closed warning light
Mandatory. An independent, fixed-intensity warning light.
- 4.12. Parking light
- 4.12.1. Presence
Optional.
- 4.12.2. Number
Dependent upon the arrangement.
- 4.12.3. Arrangement
- either two front lights and two rear lights,
- or one light on each side.
- 4.12.4. Position
- 4.12.4.1. Width:
The point on the illuminating surface which is farthest from the median longitudinal plane of the tractor shall not be more than 400 mm from the extreme outer edge of the tractor. Furthermore, if there are two lights they shall be on the sides of the tractor.
- 4.12.4.2. Height:
Above the ground : 400 mm minimum;
1,900 or 2,100 mm maximum if the shape of the bodywork makes it impossible to keep to 1,900 mm.

Annex I

- 4.12.4.3. Length:
No individual specifications.
- 4.12.5. Geometric visibility
Horizontal angle : 45° outwards, towards the front and towards the rear.
Vertical angle : 15° above and below the horizontal. The vertical angle below the horizontal may be reduced to 10° if the height of the light is less than 1,500 mm.
- 4.12.6. Alignment
Such that the lights meet the conditions concerning visibility towards the front and towards the rear.
- 4.12.7. May be "grouped"
with any other light.
- 4.12.8. May not be "combined"
with other lights.
- 4.12.9. May be "reciprocally incorporated"
- at the front : with the position lights, the passing lights, the driving lights and the fog lights.
- at the rear : with the position lights, the stop lights and the rear fog lights.
- with the direction indicators of categories 3, 4 and 5.
- 4.12.10. Electrical connections
This connection shall allow the parking light(s) which are on the same side of a tractor to be lit independently of any other lights.
- 4.12.11. Warning light
Optional. If there is one, it shall not be possible to confuse it with the warning light for the position lights.
- 4.12.12. Other requirements
The function of this light may also be performed by the simultaneous illumination of the front and rear position lights on the same side of the tractor.
- 4.13. End-outline marker light
- 4.13.1. Presence
Optional on tractors having the following dimensions :
- length : > 6 m
- width : > 2.30 m
- height : > 3 m
Prohibited on all other tractors.

Annex I

- 4.13.2. Number
2 visible from the front and 2 visible from the rear.
- 4.13.3. Arrangement
No individual specifications.
- 4.13.4. Position
- 4.13.4.1. Width:
As close as possible to the extreme outer edge of the tractor.
- 4.13.4.2. Height:
At the greatest height compatible with the required position in width and with the symmetry of the lights.
- 4.13.4.3. Length:
No individual specifications.
- 4.13.5. Geometric visibility
Horizontal angle : 80° outwards
Vertical angle : 5° above and 20° below the horizontal.
- 4.13.6. Alignment
Such that the lights meet the visibility requirements towards the front and towards the rear.
- 4.13.7. May not be "grouped"
- 4.13.8. May not be "combined"
- 4.13.9. May not be "reciprocally incorporated"
- 4.13.10. Electrical connections
No individual specifications.
- 4.13.11. Warning light
Optional.
- 4.13.12. Other requirements
Subject to all the other conditions being met, the light visible from the front and the light visible from the rear, on the same side of the tractor, may be combined in one device.
The position of an end-outline marker light in relation to the corresponding position light shall be such that the distance between the projections on a transverse vertical plane of the points nearest to one another of the illuminating surfaces of the two lights considered is not less than 200 mm.
- 4.14. Rear reflex reflector, red, non triangular
- 4.14.1. Presence
Mandatory.

- 4.14.2. Number
2
- 4.14.3. Arrangement
No individual specifications.
- 4.14.4. Position
- 4.14.4.1. Width:
The point on the illuminating surface which is farthest from the tractor's median longitudinal plane shall be not more than 400 mm from the extreme outer edge of the tractor.
The clearance between the interior edges of the reflex reflectors shall be 600 mm minimum. This distance may be reduced to 400 mm if the overall width of the tractor is less than 1,300 mm.
- 4.14.4.2. Height:
Above the ground : 400 mm minimum and 900 mm maximum. The upper limit may be increased to 1,200 mm where it is not possible to keep within the 900 mm height without having to use fixing devices liable to be easily damaged or bent.
- 4.14.4.3. Length:
No individual specification.
- 4.14.5. Geometric visibility
Horizontal angle : 30° inwards and outwards.
Vertical angle : 15° above and below the horizontal. The vertical angle below the horizontal may be reduced to 5° if the height of the light is less than 750 mm.
- 4.14.6. Alignment
To the rear.
- 4.14.7. May be "grouped"
with any other light.
- 4.14.8. Other requirements
The illuminating surface of the reflex reflector may have parts in common with the illuminating surface of any other rear light.
- 4.15. Work light
- 4.15.1. Presence
Optional.
- 4.15.2. Number
No specification.

Annex I

- 4.15.3. Arrangement
- 4.15.4. Position
- 4.15.4.1. Width
- 4.15.4.2. Height
- 4.15.4.3. Length
- 4.15.5. Geometric visibility
- 4.15.6. Alignment
- 4.15.7. May not be "grouped"
- 4.15.8. May not be "combined"
- 4.15.9. May not be "reciprocally incorporated"
- 4.15.10. Electrical connections
This lamp shall be illuminated independently of all other lights since it is understood that it does not illuminate the road or act as a signalling device on the road.
- 4.15.11. Warning light
No specifications.

no specification

with any other light

5. CONFORMITY OF PRODUCTION

5.1. Every tractor of the series shall be conform to the tractor type which received type-approval as regards the installation of lighting and light-signalling devices or their characteristics.

APPENDIX 1

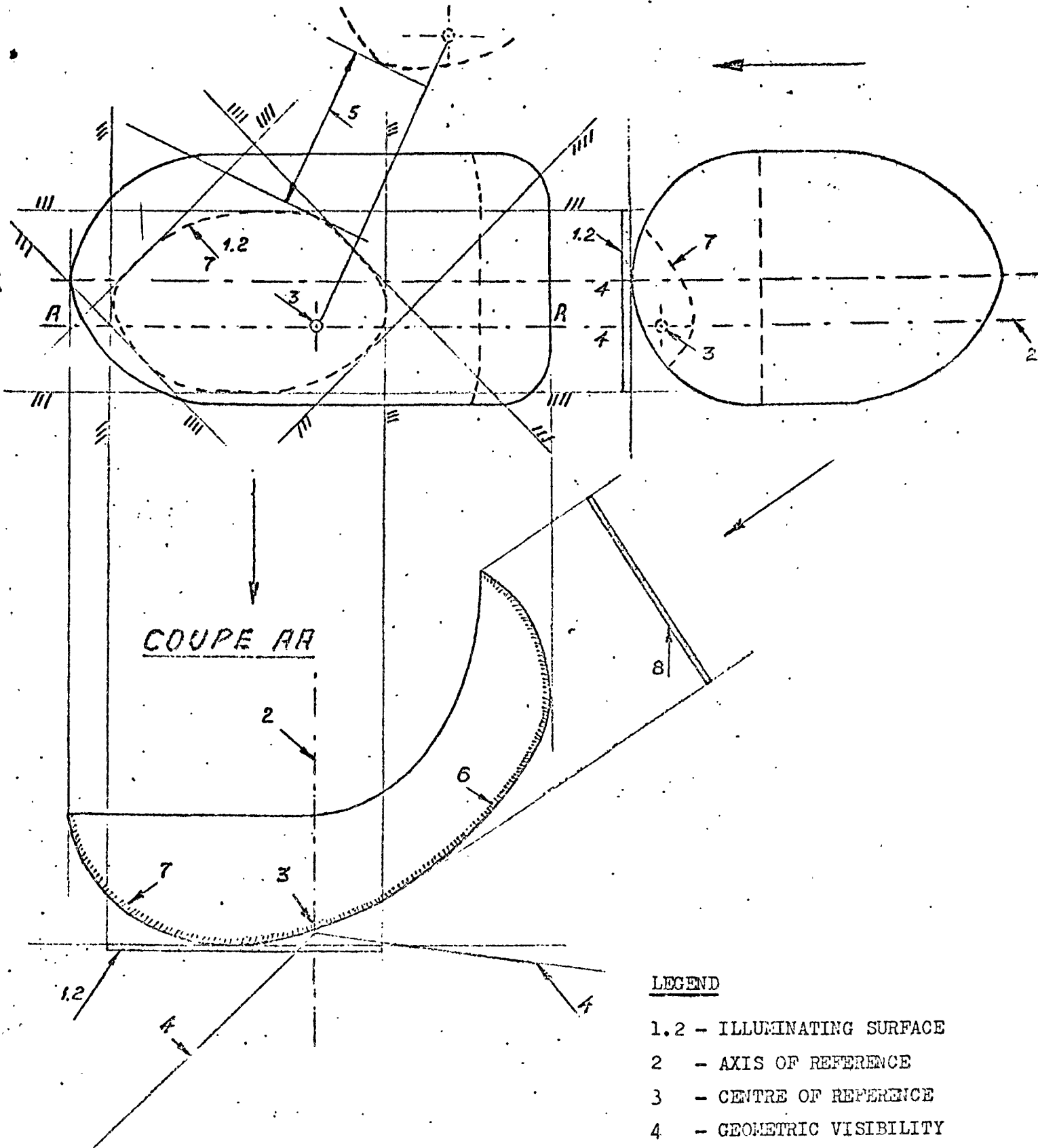

LEGEND

- 1.2 - ILLUMINATING SURFACE
- 2 - AXIS OF REFERENCE
- 3 - CENTRE OF REFERENCE
- 4 - GEOMETRIC VISIBILITY
- 5 - DISTANCE BETWEEN LAMPS
- 6 - EMISSION SURFACE
- 7 - OPERATIONAL SURFACE
- 8 - OUTER LIGHT-EMITTING SURFACE

APPENDIX 2

Fig. 1

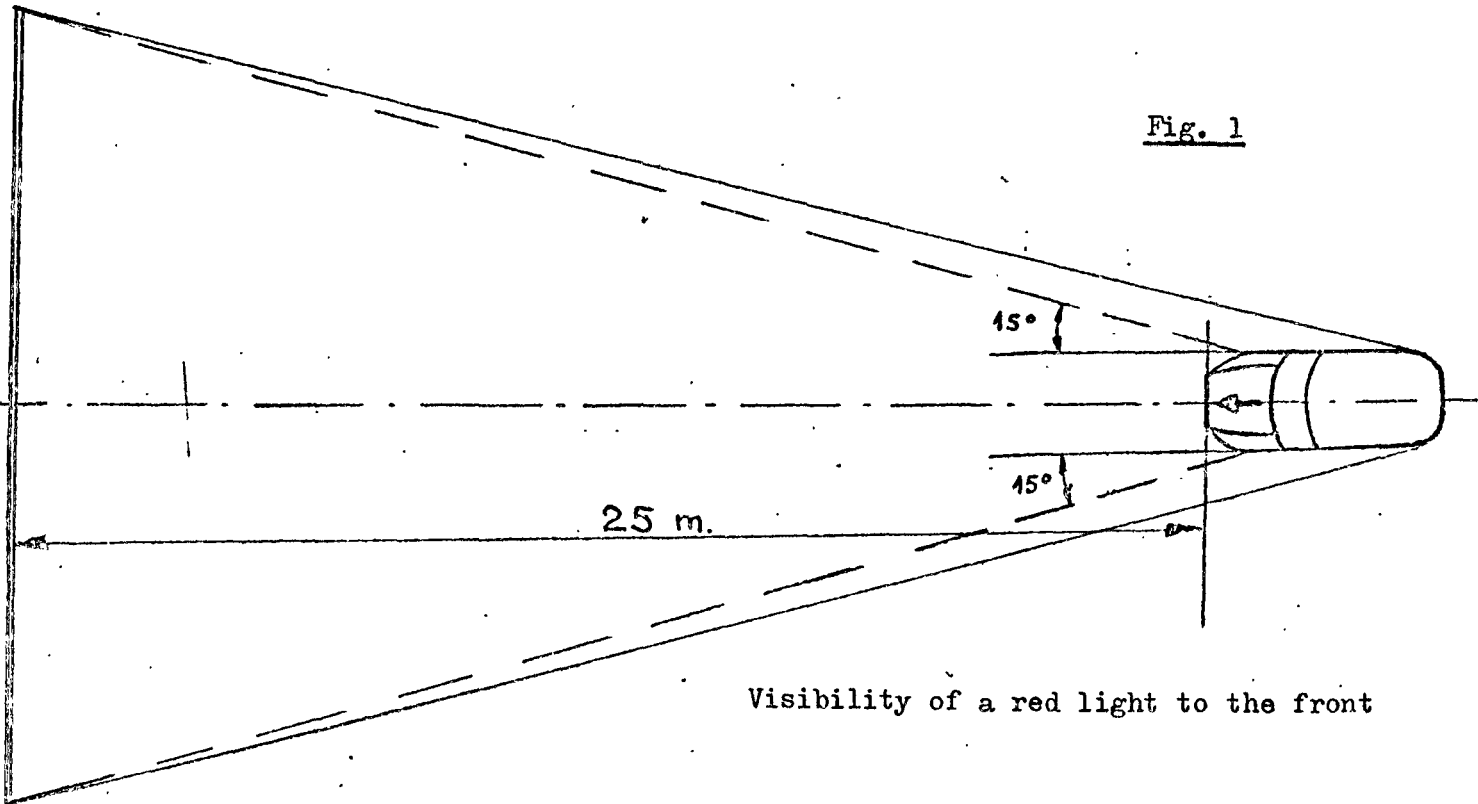

Visibility of a red light to the front

Fig. 2

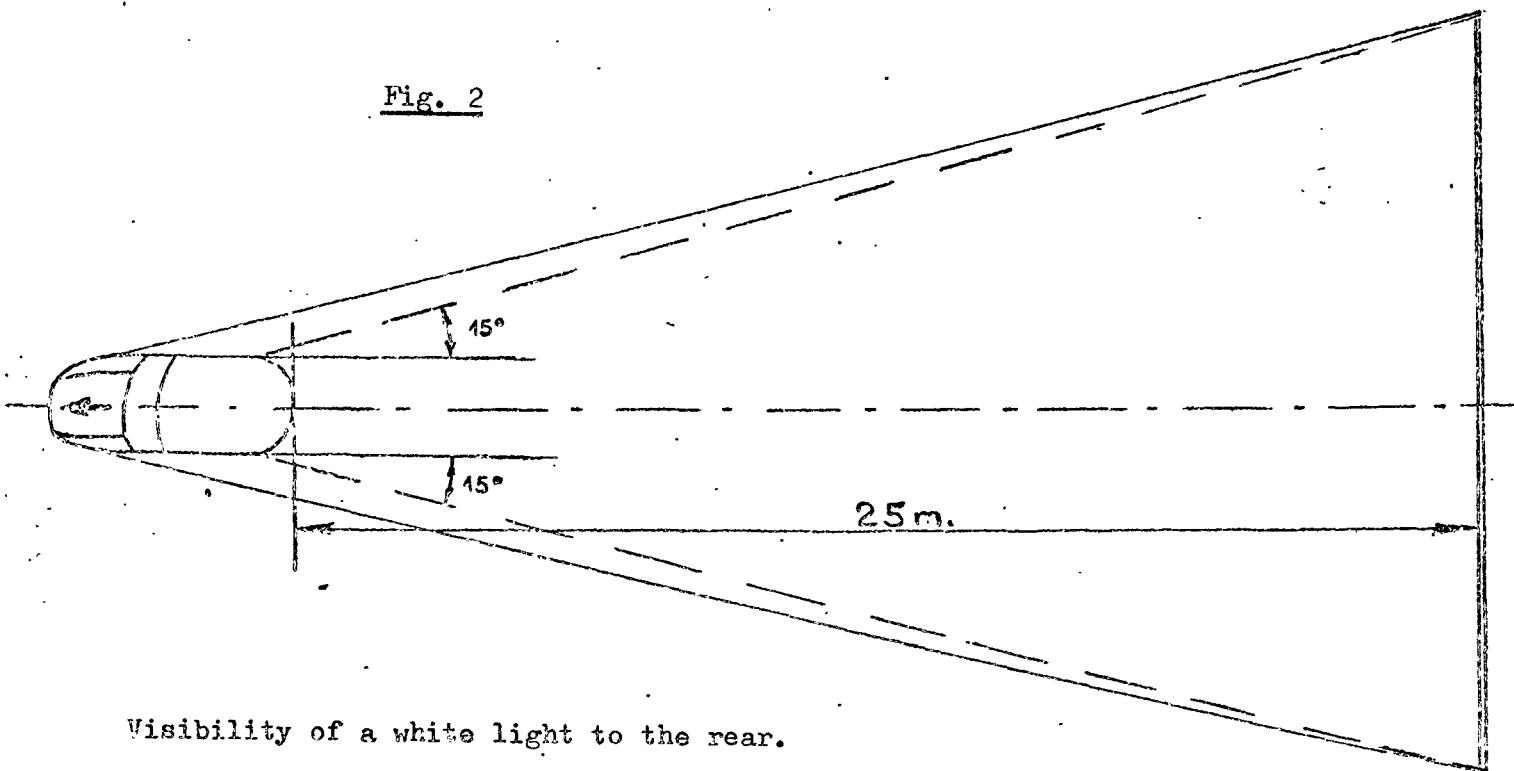

Visibility of a white light to the rear.

APPENDIX 3

Category 3

DIRECTION-INDICATOR LIGHT : GEOMETRICAL VISIBILITY

Arrangement A

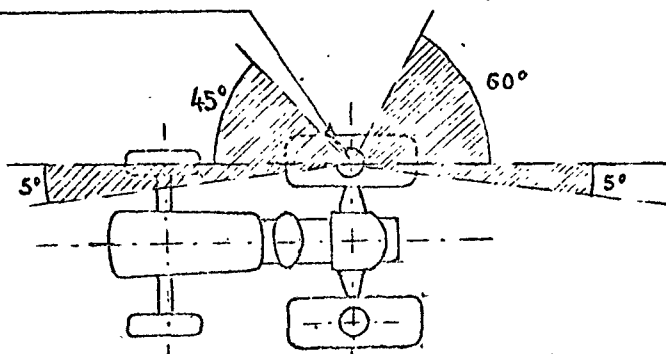

Category 4

Category 2

Arrangement B

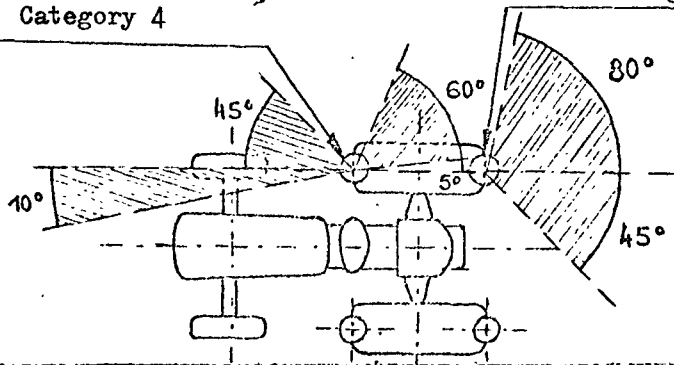

(*) The value 5° given for the dead rearward visibility angle of the front/side indicator is an upper limit, which may be increased to 10°, however, where it is a practical impossibility to adhere to the 5° limit.

Category 1

Category 2

Arrangement C

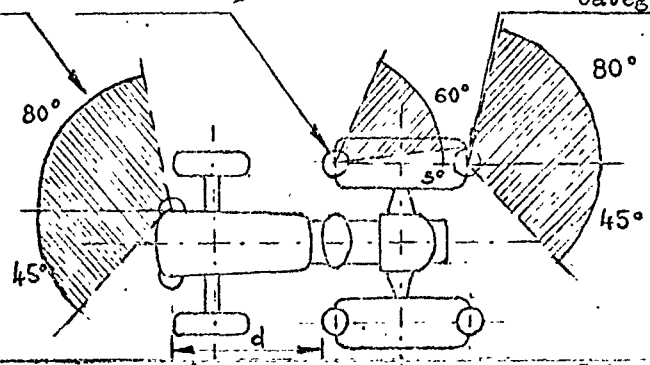

The value 5° given for the dead angle of rearward visibility of the side direction indicator is an upper limit which may be increased to 10°, however, where it is impossible to adhere to the 5° limit. The distance must not exceed 1,80 m.

Category 2

Category 1

Arrangement D

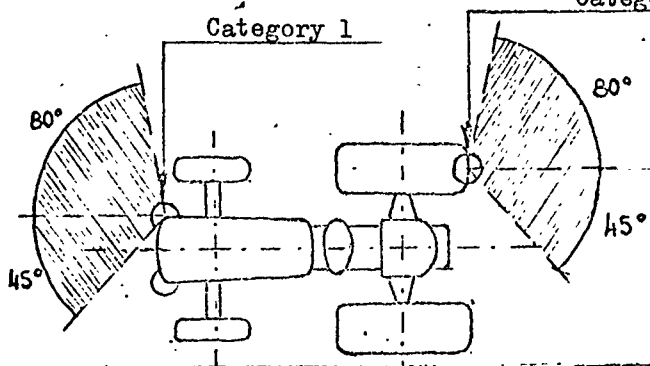

Category 1

Category 2

Arrangement E

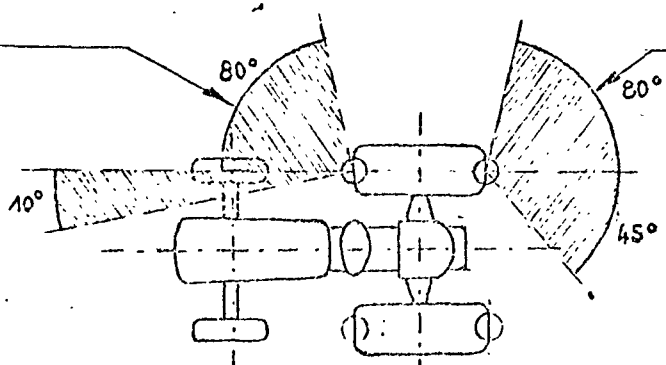

The value 10° given for the angle of inward visibility of the direction indicators may be reduced to 3° for tractors with a width overall not exceeding 1.40 m.

61

ANNEX II

Name of
administration

Annex to the EEC type-approval form for a tractor type with regard to the installation of lighting and light-signalling devices. (Articles 4, p.2 and 10 of the Council Directive of 4 March 1974 on the approximation of the laws of the Member States relating to the type approval of wheeled agricultural or forestry tractors, with a maximum design speed between 6 and 25 km/h.)

EEC type-approval N°

- 1. Make (trade name)
- 2. Type and commercial description
- 3. Manufacturer's name and address
- 4. If applicable, name and address of manufacturer's authorized representative
- 5. Lighting equipment installed on the tractor submitted for approval (1) (2)
- 5.1. Driving lights : yes/no (*)
- 5.2. Passing lights : yes/no (*)
- 5.3. Fog lights : yes/no (*)
- 5.4. Reversing lights : yes/no (*)
- 5.5. Front direction indicator : yes/no (*)
- 5.6. Rear direction indicator : yes/no (*)
- 5.7. Side direction indicator : yes/no (*)
- 5.8. Front-side direction indicator : yes/no (*)
- 5.9. Side direction indicator repeater : yes/no (*)
- 5.10. Hazard-warning signal : yes/no (*)
- 5.11. Stop-lights : yes/no (*)
- 5.12. Rear registration plate illuminating device : yes/no (*)

(1) Show for each device, on a separate form, the types of equipment duly identified as meeting the requirements for installation for the purposes of annex I.

(2) Annex the arrangement diagrams for the tractor, as shown under item 4.3. of annex I.

(*) Delete where inapplicable.

./.

Annex II

- 5.13. Front position lights : yes/no (*)
- 5.14. Rear position lights : yes/no (*)
- 5.15. Rear fog-light : yes/no (*)
- 5.16. Parking lights : yes/no (*)
- 5.17. End-outline marker lights : yes/no (*)
- 5.18. Reflex reflector rear, red, non triangular : yes/no (*)
- 5.19. Work light : yes/no (*)
- 6. Variations
- 7. Tractor submitted for approval on
- 8. Technical service conducting approval test
- 9. Date of report issued by that service
- 10. Number of report issued by that service
- 11. EEC type-approval with regard to the lighting and light-signalling devices is granted/refused (*)
- 12. Done at
- 13. Date
- 14. Signature

(*) Delete where inapplicable.

