

# COMMISSION OF THE EUROPEAN COMMUNITIES

COM (80) 369 final

Brussels, 26 June 1980

## PROPOSAL FOR A COUNCIL DIRECTIVE ON THE APPROXIMATION OF THE LAWS OF THE MEMBER STATES CONCERNING TOY SAFETY

(presented by the Commission to the Council)

COM (80) 369 final



1

4

PROPOSAL FOR A COUNCIL DIRECTIVE  
ON THE APPROXIMATION OF THE LAWS  
OF THE MEMBER STATES  
CONCERNING THE SAFETY OF TOYS

EXPLANATORY MEMORANDUM

This proposal for a Council Directive is intended to remove the technical barriers to trade and protect the health and safety of the consumer in the toy sector: in accordance with the applicable provisions of the Treaty, these two objectives were specifically included in the Council Resolutions of 21 May 1973<sup>1</sup> and 14 April 1975<sup>2</sup>.

This is not a mere coincidence. The problem of the movement of goods and that of the protection of the health and safety of the consumer are even more closely connected in this sector than in other sectors of the economy and of production. This is because the many barriers to trade in these goods in the Community derive exclusively from the disparities between the - often inadequate - laws adopted by the Member States concerning the safety of toys.

I. Disparities between the laws of the Member States. Reasons for these disparities and main features of the Community toy market

Laws on toys do not exist in all the Member States.

Those laws that are in force concern only the safety of toys and differ substantially as to scope, content and field of application:

---

<sup>1</sup> Council Resolution of 28 May 1969 drawing up a programme for the elimination of technical barriers to trade in industrial products which result from disparities between the provisions laid down by law, regulation or administrative action in Member States (OJ C 76, 17 June 1969, p. 1).

<sup>2</sup> Council Resolution of 14 April 1975 on a preliminary programme of the European Economic Community for a consumer protection and information policy (OJ C 92, 25 April 1975, p. 1).



- they cover - to varying degrees - only certain types of toys and certain types of risk presented thereby;
- the provided level of safety varies from one Member State to another and is often inadequate;
- protection - where there is any - is afforded sometimes by specific provisions relating exclusively to toys, and sometimes in the context of the general safety of goods or of certain types of goods; in the latter case, the same principles and safety criteria adopted for goods normally intended for adults are applied to toys;
- the systems, whether prescribed or authorized, for ensuring that toys comply with existing safety requirements (official inspections, in-house certification, penalties under administrative or criminal law) differ widely, are often ineffective owing to the lack of adequate structures (test laboratories, etc.) and in the end are applied preferentially to imported goods, with obvious detrimental effects on the free movement of goods;
- technical specifications and test methods, which are sometimes mandatory for certain toys, differ from one Member State to another.

During the last few years, moreover, there has been a proliferation of new regulations on this subject in the Community.

Faced with the constraints of international trade and of domestic production, and often under pressure from public opinion - which is very sensitive to the important, but partly emotional problem of child safety - the Netherlands and France have adopted widely differing regulations on toys since 1976, and other laws were recently adopted or are being prepared by Italy and Belgium. Meanwhile, the Agreement of 28 May 1969 providing for standstill and for notification to the Commission is often not applied.



This proliferation of divergent legislation, together with the upsurge of voluntary standardization at national and Community level, can be attributed both to the recent very rapid expansion of the Community toy market, which has now assumed truly international proportions, and to the inherent features of this market and of the competition from non-member countries that Community production must contend with: the legislative bodies of the Member States are thus faced with new and urgent problems which they tackle in different ways.

The principal reasons for the present disparities between the laws of the Member States relating to this sector are therefore as follows:

(a) Recent trends on the toy market

This market, which was previously marginal, seasonal and purely local, has undergone fundamental changes over the last 15 years owing to the rise in the standard of living, far-reaching changes in the child's family and school environment and a number of factors inherent in the modern consumer society.

The trend has been confirmed especially over the last few years: the number of toys increased from approximately 5 000 in 1955 to more than 60 000 in 1979. At the same time, production has increasingly shifted from craft level to industrial and technological level, small firms have combined to form medium-sized or large ones<sup>1</sup>, turnover has increased steadily<sup>2</sup> and international trade has developed. This expansion is still continuing.

---

<sup>1</sup>For example, there were 582 firms in France in 1965 and only 326 in 1976.

<sup>2</sup>For example, in France turnover increased from 355.244 million EUA in 1977 to 419.403 million EUA in 1978 (figures supplied by the French industry).



(b) Changes in the traditional features of the toy itself

The toy market is also developing qualitatively.

Besides the traditional toys - which nevertheless present variations and amazing technical improvements - increasing numbers of highly sophisticated toys are appearing on the market: electrical, mechanical and chemical toys and functional toys<sup>1</sup> that imitate the objects used by adults in their daily lives. The year 1977 marked the breakthrough of electronics in the toy industry, with the appearance of video games, remotely controlled and guided toys, etc.

Owing to their technical and technological features these toys, which are often expensive and of which sales are increasing considerably<sup>2</sup>, raise serious safety problems, which the legislator sometimes solves by resorting to the legal structures and concepts that exist at national level.

(c) Trading positions of the Member States on the market

To varying extents, depending on their standard of living, the Member States are large consumers of toys<sup>3</sup>. The Federal Republic of Germany, Italy, the United Kingdom and France, roughly in that order, are primarily producers and exporters of toys<sup>4</sup>, whereas in the other Member States the market is covered mainly by imports.

---

<sup>1</sup>For example, sewing machines, electric irons, cooking ovens and sets of utensils.

<sup>2</sup>In 1977, for example, 240 000 video games were sold in France; this figure almost doubled the following year.

<sup>3</sup>The value of imports of toys in the Member States in 1978 was, in decreasing order of importance, as follows (in thousand EUA):  
France: 294 926; Federal Republic of Germany: 280 296;  
United Kingdom: 169 920; Netherlands: 168 527;  
Belgium/Luxembourg: 145 114; Italy: 82 893; Denmark: 57 079;  
Ireland: 27 717.

These figures were taken from Nimex and include only headings 97.01 - 97.03 of the CCT, which cover only a part - albeit a major one - of the toy market. No exact data are available on the proportion of Member States' production intended for the domestic markets.

<sup>4</sup>The value of exports from the Member States to the Community and non-member countries in 1978 was, in decreasing order of importance as follows (in thousand EUA): Federal Republic of Germany: 338 261;  
Italy: 288 892; United Kingdom: 229 806; France: 96 172;  
Netherlands: 44 255; Belgium/Luxembourg: 32 110; Denmark: 13 394;  
Ireland: 5 231.



This situation is often reflected in the Member States' laws, which in some cases, since they do not necessarily have to take the exigencies of production into account, contain more stringent provisions on safety than those of exporting countries.

(d) Regulations adopted in the sector by the main toy producing and exporting and/or importing non-member countries

The United States and Japan, the world's main toy producing and exporting countries (followed by the four Member States mentioned under (c) above), have since 1969 adopted complex regulations, which are still being supplemented, laying down safety criteria for these goods. Non-member countries which are chiefly importers of toys, such as Canada, have adopted similar legislation.

The great volume<sup>1</sup> of toys that the Community exports to these countries has therefore increasingly to contend with technical barriers, while American and Japanese toys, which for some years have been achieving a significant penetration on the Community market<sup>2</sup>, are able to move freely on that market.

(e) Strong competition on the Community market from exports originating in new producing countries in the Far East

Exports to the Community from new producing countries in the Far East have been steadily increasing since 1977: for example, exports to France from Hong Kong doubled between 1977 and 1978<sup>3</sup>.

These toys<sup>4</sup>, which are generally less expensive owing to low labour costs in these countries but do not always exhibit the essential safety features, are competing keenly with Community production: the legislators in the Member States are consequently reacting variously, according to their country's position on the market<sup>5</sup>.

---

<sup>1</sup>Community exports to non-member countries in 1978: 640.722 million EUA.

<sup>2</sup>Community imports from non-member countries in 1978: 798.812 million EUA.

<sup>3</sup>Figure supplied by the French industry.

<sup>4</sup>Mainly textile toys, puppets and dolls, clockwork toys, parlour games and video games.

<sup>5</sup>See point (c) on page 4 of this Explanatory Memorandum.



II. Consequences of the disparities between the laws of the Member States on the movement of goods within the Community and the protection of the consumer

At this point it is possible to determine the consequences of the disparities between the laws of the Member States, as set out in section I of this Explanatory Memorandum, on the establishment and proper functioning of the common market in toys.

It certainly cannot be said that the free movement of goods has been achieved.

Technical barriers to trade are at the present time numerous and far-reaching. Proof of their existence is provided by the fact that frequent complaints are formally or informally lodged with the competent departments of the Commission, and -- perhaps even more conclusively -- by the innumerable steps taken at European and world level by the national and European industries, in order to reach inter-trade agreements that are likely to provide at least a partial solution to these problems.

These barriers to trade will also probably tend to increase as a result of new laws recently adopted by the Member States, the effect of which on the movement of toys within the Community obviously cannot yet be assessed.

As regards the protection of consumers against the hazards arising from toys, it must first of all be said that such protection is rarely effective and never complete.

It is true that the laws of some Member States, in line with the higher level of development of consumer rights in these countries, afford a greater degree of protection than those of other Member States; nevertheless, such protection -- which in any case cannot cover all hazards and all categories of toys -- can be rendered effective only if the free movement of goods within the common market is hindered by subjecting



7

goods originating in other Member States to systematic verifications of conformity before they are placed on the market in a given Member State. Such verifications are impossible in view of the number and variety of toys.

A survey of the laws of most of the Member States shows that provisions effectively protecting children against the many hazards that toys are liable to present are often completely lacking. This gap has been only partly filled by laws which were hastily adopted recently in certain Member States and of which the effectiveness as regards the protection of children has yet to be proven.

Statistics of accidents caused by the use of toys<sup>1</sup>, together with the experience of the everyday life of children, amply demonstrate this need for protection, which has been confirmed by inquiries conducted by other international organizations<sup>2</sup> and is often ignored or sacrificed to the needs of production.

Community consumers for their part are calling for genuine protective measures that are valid throughout the Community and for all toys, since it is especially in the countries and regions where individual income is lowest that the least expensive - and often most dangerous - toys are bought. Parents are baffled by the vast number of trade names and by the claims - sometimes unfounded - which for some time have been appearing on toys marketed in certain Member States and which, mainly with a view to promoting sales, promise or certify a degree of safety that in some cases is purely illusory; consumers are calling for such practices to be banned or at least restricted within legally acceptable limits.

---

<sup>1</sup>See the report on "Safety Requirements for Toys" published in September 1975 by the OECD Committee on Consumer Policy. The statistics given in this report were supplied mainly by the United Kingdom and the USA.

<sup>2</sup>Mainly the OECD (see the report referred to in footnote 1). The problem is also being tackled by ISO, which has set up an ad hoc working party under the Committee for Consumer Policy (COPOLCO).



III. Particular features and main points of the proposed system

In order to obviate the disadvantages described in section II, as regards both the movement of goods and the protection of the physical health of consumers, this proposal provides for an overall system for ensuring the safety of toys.

Under scrutiny, the toy sector is seen to differ structurally from the other sectors of production: from the safety standpoint, it poses problems that are fundamentally different in nature and magnitude from those raised by other industrial or consumer goods.

In the preparation of this proposal it has therefore been possible to draw only to a limited extent upon existing directives relating to other sectors, and it has been necessary to take as a basis the special features and aspects presented by toys since these are a decisive factor as regards the rules to be adopted.

The following are the main features of the toy sector:

- (a) toys are very widely-distributed consumer goods, and their distribution is bound to increase in line with the accelerated rise in the standard of living which the Community is required to promote in pursuance of Article 2 of the Treaty;
- (b) the number of toys is virtually unlimited: the figures<sup>1</sup> for the number of toys at present on the market (more than 60 000) are of no more than indicative value if we consider the enormous diversity of these goods, which can exhibit widely differing technical, aesthetic and functional features. With the possible exception of the food industry no other sector covers such a wide quantitative range;

---

<sup>1</sup>See section I, point (a), p.3.



- (c) toys are many-faceted products whose main characteristic is extreme mobility: any article or product used by adults in any walk of life may, if specially adapted in size, function or performance, become a toy and be sold as such; the already large category of functional toys will undoubtedly expand in view of the increasing development and precocity of children in modern society;
  
- (d) toys, like other products, can present hazards which are either due to the characteristics of their manufacture and composition or derive from a utilization that does not conform entirely to their function and operating instructions. Unlike other products, however, which present only the hazards inherent in the category to which they belong or, at most, a fairly narrow range of hazards, toys can present, to an extent that varies according to whatever category of objects to which they may belong, all imaginable hazards: hazards deriving from physical and mechanical properties, flammability hazards, chemical hazards, health hazards, explosion hazards, radioactivity hazards, etc.;
  
- (e) toys are designed exclusively for children, i.e., for a special category of users, who by definition do not exercise the same degree of care which can be expected from adult users of other products.

It is a universally accepted legal principle that, in the case of products that pose safety problems, the magnitude of the hazards and hence the degree of protection that must be afforded by the law-making body depend mainly on the extent to which the user is able to safeguard himself against such hazards; children using toys cannot be expected to display the necessary care to safeguard themselves, or can be expected to do so only to a limited extent.

The specific problems relating to the safety of toys therefore mainly result from the fact that this is a



sector in which the hazards are extremely varied but the consumers are scarcely conscious of them. This again is a basic feature which applies solely to toys and distinguishes them from all other consumer goods.

In order to take into account the features and requirements specific to the toy sector, it was necessary to include in the proposed system special provisions that differ somewhat from those of other directives on the free movement of goods and the safety of consumers, but are essential for the attainment of the objectives envisaged for this sector.

In particular:

1. In view of the actual and potential extent of the toy market, and especially its mobility, the scope of the Directive had to be determined on the basis of a wide definition of toys which is nevertheless rooted in the objectively discernible features of these goods. Exceptions have had to be precisely defined, and catch-all provisions included in order to cover goods which are on the borderline of this definition and which, although normally intended for adults, can in certain cases be marketed as toys<sup>2</sup>.
  
2. The general level of safety had to be legally defined<sup>3</sup> in relation not only to the criterion of proper use in accordance with the function of the product but also to the misuses to which children can normally be expected to subject them. This basic principle, which differs sharply from the concepts adopted in other directives, is unquestionably justified by the requirements set out in point (e) of this section.

---

<sup>1</sup>See Article 1 of the proposal for a Directive.

<sup>2</sup>See Annex II to the proposal for a Directive.

<sup>3</sup>See Article 2 of the proposal for a Directive.



3. Because of the number and, more particularly, the actual and potential diversity of the technical characteristics of toys, it was not possible to base the proposed safety system for these products exclusively on uniform technical standards in respect of design and composition.

From the practical standpoint it is impossible to define exhaustively and in advance the technical safety specifications to be applied to all toys that present a potential hazard for the user.

Apart from the drafting difficulties involved, an excessively complex system of standards might confine the highly diversified technique of toy manufacture within a rigid framework of standardization which would be difficult to update and which could prove inadequate and unnecessarily restrictive for the industry.

For these reasons, the mandatory common technical safety standards, laid down in Article 4 of the proposal and relating to the principal design and composition features of most toys, co-exist, in the system established by the Directive, with a general safety principle enunciated in Article 2 and applicable to all toys.

This principle, which is supplemented by general safety objectives<sup>1</sup> relating to the many different hazards associated with toys, constitutes the legal basis and starting-point for the technical standards and is also of considerable legal significance since it applies directly to toys which are not covered by those standards.

The safety system defined in the Directive is therefore essentially all-embracing: whilst being based on mandatory common standards, which are indispensable if the free movement of the goods in question is to be

---

<sup>1</sup> See Annex III to the draft Directive.



AL

achieved, it also defines the means that are necessary to ensure the safety of children in cases where there are as yet no precise technical specifications at Community level governing toys.

The indispensable common technical standards in this field will be gradually supplemented<sup>1</sup> by ad hoc directives, the drafting of which is provided for in this proposal.

4. For the reasons indicated in point (e) of this section, children are particularly vulnerable to potential hazards arising from a failure to use toys in accordance with their specific functions.

Although these hazards, since they relate exclusively to use, could not be eliminated by the application to toys of technical specifications governing design and composition, they could be avoided by indicating a minimum age for use or by warnings and suitable instructions for use<sup>2</sup>.

This proposal makes provisions in this respect which would apply directly to toys, particularly the more dangerous types<sup>3</sup>.

These provisions make it possible, in particular, to keep within objectively reasonable limits the general safety obligation devolving on those responsible for the marketing of toys and, at the same time, define the essential legal distinction between this obligation and those laid down in civil law, which apply to parents, supervisors, teachers and others responsible for children's activities.

---

<sup>1</sup>See Article 5 of the Directive.

<sup>2</sup>See Annex III, Section 1 of the draft Directive for the distinction between hazards associated with design and/or composition and hazards associated with use. The former hazards are also dealt with in point 5 below.

<sup>3</sup>See Article 7 and, in particular, Annex IV of the draft Directive.



5. The range of potential dangers presented by toys is extremely varied<sup>1</sup>.

The proposal identifies the various hazards according to their type and origin in a way which, without being legally exhaustive, is virtually complete: hazards arising from physical and mechanical properties, hazards due to electrical properties, ignition hazard, chemical hazards, explosion hazards, hazards due to the hygiene characteristics or radioactivity of the product.

The general safety objectives associated with each of these hazards are also defined: they are set out in the form of technical specifications in Annexes V and VI<sup>2</sup> to this proposal or will, where necessary, be set out in the ad hoc directives referred to in Article 5.

6. As regards official checks on the conformity of toys with the provisions of the Directive, an inspection conducted prior to marketing, although theoretically desirable from the safety standpoint, is not feasible because of the large number of products involved and the associated costs, which would be out of proportion to the frequently low value of the toys.

The arrangement provided for in this proposal is therefore one of non-systematic a posteriori verification: the checks, which will be performed on products on the market by the competent authorities of the Member States pursuant to national procedures, will be carried out, where necessary, at sales and storage points, by way of inspection in factories, etc.

In general, the numerous directives authorizing such checks do not contain a specific clause in this respect: as a matter of common interpretation,

<sup>1</sup>See point (d) of this section, page 9

<sup>2</sup>These annexes contain the common technical standards relating to the physical and mechanical properties (Annex V) and to the inflammability (Annex VI) of toys; they cover - with certain adaptations - the CEN (European Committee for Standardization) standards EN71-1 of 27.10.1978 and EN71-2 of 8.5.1978.



harmonization clauses, whether total or optional, which appear in these Directives, and the standard formula "Member States shall take all measures necessary...."<sup>1</sup> are normally understood as permitting Member States to perform these checks.

Checks, even if non-systematic, on the safety of toys are nevertheless particularly<sup>2</sup> necessary for the reasons indicated in points (d) and (e) of this section : were there to be no checks at all, or were checks to be performed only sporadically, the safety system set out in the Directive would become a dead letter.

That is why an express provision to this effect has been included.

This provision also requires Member States to send to the Commission a report on the results of the checks performed during the first three years of the application of the Directive. The obvious purpose of such a report is to ascertain whether, and if so to what extent, the safety system proposed here has in fact made it possible to achieve the objectives of free movement of goods and protection of the health and safety of children.

7. Considerable difficulties may be encountered in performing the official checks referred to in point 6 above owing to the quantity and variety of toys on the market: the most serious problem in this connection is that of costs, which will clearly be in proportion to the number of checks required and therefore excessively high.

In order to limit the number of these checks and to ensure that they are performed on the most dangerous toys, the following measures are provided for:

---

<sup>1</sup>See, for example, the wording employed in Article 3.1 of the draft Directive.

<sup>2</sup>See page 9.



(a) On the basis of a technical report drawn up by one of the bodies designated by the Member States, consumer associations can notify the supervisory authorities of any toys available on the market which were found to be particularly dangerous when used<sup>1</sup>.

In this way the consumers, who clearly have considerable direct experience in this field, are accorded an active, valuable, and indeed necessary, role in the implementation of the system. In certain Member States, moreover, consumer associations possess an organization for this purpose and have direct tests conducted on various consumer products, particularly toys, in order to check their safety or other essential features.

(b) In order to comply with the safety obligations devolving upon them, those responsible for marketing are, in practice, required to commission a test laboratory to verify the conformity of the product in question where they cannot perform this verification themselves.

The Directive provides<sup>2</sup> that in such cases they can obtain a certificate of conformity entitling them to affix to toys complying with the type that has passed the tests, a standard EEC symbol which is recognized as a presumption of conformity by the competent authorities in the Member States.

In this way the number of checks required is substantially reduced.

The abovementioned method (EEC symbol of conformity) is a very flexible procedure which can be applied to highly diversified products of low economic value such as toys. It incorporates, though in a greatly simplified manner, the essential elements of the "type-approval" methods

---

<sup>1</sup>See Article 12 of the draft Directive.

<sup>2</sup>See Article 4.3 and Annex VII of the draft Directive.



and of similar procedures laid down, in particular, in the Directives on measuring instruments<sup>1</sup> and pressure vessels<sup>2</sup>.

(c) Where the persons responsible for placing toys on the market are in a position to check the conformity of their products directly, they can affirm such conformity on their own responsibility according to a standard procedure laid down in the Directive<sup>3</sup>. This possibility was provided in view of the limited number of test laboratories in the Community: in no circumstances could these laboratories check the conformity of all toys placed on the market.

In this case, moreover, the declaration by the person responsible for marketing commits that person alone; it has tone only in private law and does not confer any presumption of conformity as regards official checks.

In particular, the use of this declaration for purposes of promotion and publicity is expressly forbidden<sup>4</sup>, and Member States are required to introduce any penalties that may be necessary in this connection; indeed, one of the basic principles of the Directive is that the safety of toys, which is a legal obligation on the person responsible for marketing them, must under no circumstances be commercially exploited.

This proposal also contains other provisions which are relatively new by comparison with existing Directives, in particular those concerning the withdrawal of dangerous products from the market<sup>5</sup> and the advertising of toys<sup>6</sup>; like the latter, these proposals are

---

<sup>1</sup>Council Directive 71/316/EEC of 26 June 1971 (OJ No L 202, 6.9.1971).

<sup>2</sup>Council Directive 76/767/EEC of 27 July 1976 (OJ No L 262, 27.9.1976).

<sup>3</sup>See Article 4.4 of the draft Directive.

<sup>4</sup>See Article 13(d) of the draft Directive.

<sup>5</sup>See Article 10 of the draft Directive.

<sup>6</sup>See Article 13 of the draft Directive.



designed, pursuant to the principles embodied in the Treaty, to bring about a common market in this important and very specialized sector of the economy.

It was thought necessary to include detailed technical provisions in this proposal for a Directive, on account of the specific nature of the field and special features of the proposed system which, among others, provides for the complete harmonization of Member States' legislations.

In view of the child's limited ability to foresee and avoid the dangers presented by toys, only by laying down specifications applicable at the time of its manufacture and, in any case, before it is marketed, can these dangers be eliminated.

To determine such specifications is a very delicate matter and, in addition to the usual technical standards applied, involves a more subjective evaluation as regards the standard of safety to be established in each case: in general, such an evaluation is founded on industrial, commercial or political considerations reflecting the degree of sensitivity of the individual Member States as regards the safety of children.

Consequently, the only solution was to submit these common technical standards to the Council for its approval by incorporating them in this Directive (Annexes V and VI) or in the Directives for which provision is made in Article 4(1). These standards are an essential complement to the principles and general safety objectives set out in Article 2 and Annex III, and are accordingly vital to the system established by the Directive.

This solution, adopted to meet the particular requirements of the proposed instrument, is in no way counter to the principle generally followed by the Commission as regards the delegation of powers with respect to the adoption of strictly technical harmonization measures. In this respect, Commission policy is clearly favourable to the broadest utilization of the possibilities provided for in the fourth indent of Article 155 of the Treaty.



78  
THE COUNCIL OF THE EUROPEAN COMMUNITIES,

Having regard to the Treaty establishing the European Economic Community,  
and in particular Article 100 thereof,

Having regard to the proposal from the Commission,

Having regard to the Opinion of the European Parliament,

Having regard to the Opinion of the Economic and Social Committee,

Whereas several Member States have mandatory rules governing the safety characteristics of toys, but these rules differ in their scope and content; whereas this situation produces major barriers and creates unequal conditions of competition within the Community, as well as failing to provide Community consumers, especially children, with adequate protection against the hazards arising from the products in question;

Whereas these obstacles to the establishment and functioning of the common market should be removed, and whereas for this purpose the marketing of and trade in toys should be made subject to uniform rules, applicable in all Member States, based on the objectives regarding protection of consumer health and safety as set out in the Council Resolution of 14 April 1975<sup>1</sup>;

Whereas total harmonization in this area is necessary, since children's health and safety cannot be allowed to remain subject to different standards of protection in the various Member States;

Whereas in view of the size and mobility of the toy market and the diversity of the products concerned, the scope of this Directive should be determined on the basis of a sufficiently broad definition of "toy", supplemented, to obviate differences of interpretation, by an illustrative list of the main types of products involved;

---

<sup>1</sup>OJ No C 92 of 25 April 1975.



Whereas products on the borderline of this definition should be expressly excluded from the scope of the Directive, but whereas for some of these the Directive's provisions should remain applicable if they are marketed as toys, whilst for others of a particularly dangerous kind steps prohibiting their marketing as toys should be taken directly by the Member States;

Whereas only toys that are safe should be placed on the market; whereas, therefore, those responsible for placing such products on the market are under a general obligation to ensure their safety; whereas the standard of safety of toys should be determined in relation to the criterion of the correct use of the product in question, but with allowance also made for foreseeable misuse by children, who generally do not show the same degree of care as the average adult user; whereas special rules should be laid down for toys intended for very young children;

Whereas toys may present different types of hazard, because of their differing properties, features and functions; whereas the most important and common types of hazard should be stated, and the general safety objectives in regard to such hazards should be set out;

Whereas hazards inherent in the use of toys can only be avoided by means of suitable warnings and instructions accompanying the toy; and whereas such warnings and instructions for general use or for use on particular types of toys should be specified and made mandatory;

Whereas hazards arising from the construction or composition of toys can only be eliminated if their construction and composition is subject to technical safety specifications; whereas such specifications should be incorporated, with the relevant testing methods, in common technical standards for toys applicable in all the Member States;



Whereas the common technical standards for the physical and mechanical properties and flammability of toys can be prescribed in this Directive; whereas standards in respect of other types of hazards in toys will be laid down in specific Directives on the basis of the general safety objectives with regard to the hazards concerned;

Whereas, to ensure that the Directive is properly applied by those responsible for placing toys on the market, it is essential that laboratories of assured impartiality be available in the Member States to verify on request the conformity of toys to the common technical standards and to issue certificates of conformity; whereas, to facilitate inspections by the Member States' authorities, parties obtaining such a certificate should be entitled to affix to toys complying with the tested samples the EEC symbol of conformity described in the Directive and recognized as evidence of conformity by the abovementioned authorities;

Whereas, in view of the shortage of test laboratories in most Member States, it would be desirable to allow those concerned who are able to verify the conformity of toys to the common standards directly to declare that conformity on their own responsibility according to a standard procedure laid down in the Directive, without such a statement carrying any legal implications in regard to the official inspections and provided it is not used for promotional or publicity purposes;

Whereas, to avoid freezing the ever-changing technology in the toy industry at the stage represented by the common technical standards, manufacturers should be allowed to make toys to technical specifications other than those required by the standards, provided that such specifications accord with the general objectives set out in the Directive and that the manufacturer establishes the safety of his technical innovations by obtaining a report on the toy concerned from a recognized laboratory;



Whereas the provisions of general law governing the responsibility of parents, supervisors and teachers are an essential complement to the safety measures provided for in the Directive, and whereas this law imposes the obligation, as regards the choice of toys and the supervision of children at play, in particular to observe the minimum age limits specified for certain toys and make sure that any necessary safety precautions recommended in the instructions are taken;

Whereas it would be of value -- and may even be a necessity -- for the operation of the system of toy safety set up by the Directive that checks should be carried out, not necessarily on a systematic basis, by the Member States' authorities on the safety of toys on their markets; whereas in view of the inevitable difficulties such checks will face because of the vast numbers of toys on sale, consumer associations should be enabled to play an active part by drawing the authorities' attention to toys needing checking, on the basis of a technical report prepared by one of the recognized laboratories;

Whereas cases might arise where a toy, although meeting the requirements of the provisions of Articles 4 to 7 of this Directive, in particular the common technical standards, nevertheless presents a hazard to the health and safety of users; whereas, therefore, a safeguard clause establishing a suitable procedure should be laid down for dealing with such cases;

Whereas, in line with the principles set out in the Council Resolution of 14 April 1975, any toys found to be dangerous should be withdrawn from the market without delay; whereas, whenever a Member State orders such a withdrawal, the other Member States and the Commission should be informed so that it is effective throughout the Community;

Whereas, in the conditions in which children grow up today, toy advertising, especially on television, is a powerful instrument of persuasion and encouragement to consumption of this product; whereas this instrument also affects the people, parents, teachers, etc., forming the family environment of children; whereas it is therefore vital, if toy safety is to be ensured, that advertising be subject, without prejudice to



national legislation on misleading advertising, to basic provisions aimed at protecting consumers against misleading information about the safety characteristics and performance of toys and ensuring that they are informed of the safety precautions and minimum age limits relating to the use of certain toys; whereas steps should be taken to guard against the exploitation of toy safety for sales promotion purposes;

Whereas the technical requirements set out in the Directives on toy safety will need to be adapted promptly to take account of advances in technology; whereas, to enable the necessary steps to be taken to this effect, a procedure should be set up providing for close cooperation between the Member States and the Commission through a Committee for the Directives on Toy Safety; whereas this procedure should also be applied in determining the sampling methods and the test methods relating to the common safety standards to be established by the Council Directives provided for in the third subparagraph of Article 4(1);

HAS ADOPTED THE FOLLOWING DIRECTIVE :



Article 1

Scope and definitions

1. A "toy" means any product manifestly intended for the use in play by children of not more than fourteen years of age, including writing, drawing and colouring materials and handicraft equipment marketed as instruments of play for such children.

In particular, the products listed as examples in Annex I shall be regarded as toys.

Products listed in Annex II shall not be regarded as toys.

2. "Functional toys" means any article which fulfils the same function as certain products, appliances or installations which are intended for adults and which often are scale models thereof.

"Functional parts of a toy" means any parts which could not be modified or eliminated without changing the specific function of the toy or modifying its basic features.

3. The terms "manufacturer" and "seller" mean respectively a manufacturer or seller established in the Community.

"Importer" means only an importer, established in the Community, of toys from non-member countries.



Article 2

General principle of safety  
and related provisions

1. Taking into account the use for which they are normally intended and the reasonably foreseeable misuse children can make of them, toys shall not endanger the safety or health of children, whether users or others, or any other person.

Special provisions and more stringent requirements shall apply to toys which, on account of their function, dimensions and characteristics, are likely to be given to children of less than 36 months. Examples of toys intended for such children appear, in particular, in points 1 to 11 of Annex I.

Minimum age limits for the use of certain toys shall be indicated by the manufacturer, importer or vendor in cases covered by the provisions of this Directive; in other cases the manufacturer, importer or vendor may indicate such limits in the light of the dangers involved and the presumed mental and physical ability of a child to cope with them.

The general safety objectives concerning the provisions in the preceding paragraphs are listed in Annex III.

2. Toys shall exhibit the technical safety characteristics and bear the particulars and warnings provided for in this Directive, in the condition in which they are marketed. The safety characteristics must be maintained over a period of time, in accordance with paragraph 1 and having regard to the normal rate of wear of each type of toy.



3. Where a toy has to be assembled, the finished toy as well as each one of its elements shall present the technical safety characteristics provided for in this Directive; if it is specifically stated that the toy must be assembled by an adult, only the finished toy need present these characteristics.

### Article 3

#### 1. TOTAL HARMONISATION CLAUSE

Member States shall take all necessary steps to ensure that toys cannot be placed on the market unless they comply with the provisions of this Directive and of the Directives provided for in Article 4.0.

#### 2. FREE CIRCULATION CLAUSE

Member States may not, for reasons related to safety, refuse, prohibit, restrict or hinder the placing on the market and free circulation within the Community of toys which comply, under the conditions provided for in Articles 4 to 7, with the provisions of Article 2.

### Article 4

#### Common Technical Standards

1. Toys, in order to comply with the requirements of Article 2, must be manufactured according to the common technical standards concerning:
  - a) risks arising from the "physical and mechanical properties" and the "flammability" of toys,
  - b) risks arising from the "chemical and toxicological properties" as well as from the "electrical properties" of toys,
  - c) risks, in particular those referred to in Annex III, other than those referred to under a) and b) above.

The common technical standards covering the risks mentioned in a) as well as the related testing methods are laid down in Annex V and VI of this Directive.



Council directives will establish the common technical standards concerning:

- the risks referred to under b) and c);
- those toys not covered by Annex V and VI which present specific risks, such as aquatic toys and children's craft.

The general safety objectives set out in Annex III shall apply to safety aspects which are not covered by the above mentioned standards.

2. Toys must furthermore bear the information and warnings prescribed by Article 6 and 7 of this Directive.
3. Member States shall take all necessary steps to enable any manufacturer, importer or vendor who wishes to verify the conformity of the toy with the standards referred to in paragraph 1 to have the appropriate tests carried out by one or more of the laboratories designated in accordance with the terms of Article 18 and to obtain a certificate of conformity with these standards.

The manufacturer, importer or vendor who has obtained such a certificate may affix the EEC symbol of conformity referred to in Annex VII only to toys identical with the tested sample.

Without prejudice to other methods of proof, the appearance on toys of the symbol referred to in the previous subparagraph shall be accepted by the competent authorities as a presumption of conformity to the common technical standards.

4. Without prejudice to the provisions of Article 13(d), the manufacturer, importer or vendor may also, on his own responsibility, affix the following statement to the toys: "DECLARED BY THE MANUFACTURER, IMPORTER AND/or VENDOR TO CONFORM TO THE MANDATORY COMMON STANDARDS", to be followed by a reference, using the initials set out in Annex VII, to the standards specified in paragraph 1 with



which the toy is declared to conform. The details specified in Article 6(1)(a) must also be given.

The Member States shall specify the penalties to be applied in the case of false declarations.

5. Any type of distinctive safety sign (marks, declarations, certificates, etc.) shall be prohibited. Conformity symbols or declarations other than those referred to in paragraphs 3 and 4 shall not be permitted.

## Article 5

Toys with technical specifications  
other than those provided for in the common technical standards

1. Toys may also be manufactured according to new technologies entirely or partially entailing technical safety specifications other than those provided for in the common technical standards referred to in Article 4(1), provided that these specifications meet the general safety objectives set out in Annex III.

For this purpose, the manufacturer, importer or vendor shall have the toy examined by a laboratory designated in accordance with Article 18, and shall obtain a technical report certifying that the toy complies with the conditions referred to in the previous subparagraph. The words "Report n° ..... of laboratory .....", together with the name of the laboratory which has prepared the report, must appear on the toy or its packaging; it may, where appropriate, be combined with the EEC symbol of conformity or the declaration provided for in Article 4(3) and (4).

When the checks provided for in Article 8 are carried out, the report shall be presented, upon request, to the competent authorities in the Member States.

2. The toys referred to in paragraph 1 must also bear the information and warnings prescribed by Articles 6 and 7.



3. The cases to which this Article applies shall be notified to the Commission for the possible application of the procedure referred to in Article 17.

### Article 6

#### Particulars to be given on the toy or its packaging

1. The following particulars shall be given on each toy or its packaging:

- a) the name and/or trade name and/or mark as well as the address of the manufacturer or the importer and/or vendor.

These particulars may be abbreviated insofar as the abbreviation makes it possible, in a general and evident manner, to identify the company.

- b) the minimum age for use of the toys in cases covered by Annex IV, 6b and 9b or in cases where the option provided for in the third subparagraph of Article 2(1) is exercised;

- c) the indications and warnings prescribed by Article 7 and Annex IV and by the Directives referred to in Article 4(1);

- d) where appropriate, the EEC symbol of conformity or the manufacturer's declaration provided for in Article 4(3) and (4) and/or the number of the technical report referred to in Article 5(1).

2. The particulars specified in paragraph 1 shall be given, in such a way as to draw the attention of users and buyers, as follows:

- in the case of those referred to in a), b) and d), on the toy or its packaging;

- in the case of those referred to in c), on the toy, the packaging or the instructions for use, in accordance, in particular, with Annex IV and with the Directives referred to in Article 4(1).



The lettering shall be at least 3 mm in height, easily legible and indelible, and shall contrast with the background of the toy or the packaging.

3. The particulars specified in paragraph 1 b) and c) shall also be given in summary form in all catalogues, folders and prospectuses. Samples and packaging of toys displayed to the public in shops, windows, etc. or used when offering the goods for sale shall give, as regards points b) and c) of paragraph 1, the same particulars as those which must be affixed to the toys offered for sale to the consumer.

Furthermore, any particulars, information, names or marks other than those provided for in this Directive, and any pictorial matter or other symbols appearing on toys and their packaging or in the catalogues, folders, etc. referred to in the previous subparagraph may not be such as to give rise to confusion with the information required under paragraph 1.

4. Subject to the provisions of Articles 30 - 37 of the Treaty, Member States may require that the particulars provided for in paragraph 1(b), (c) and (d) shall also be given in their own national language or languages.

#### Article 7

##### Warnings and details of precautions to be taken

Any toys likely to present dangers inherent in their use or which require special precautions must display a notice drawing attention to these dangers and stating the precautions to be taken in respect of use and whether supervision is necessary.

Annex IV prescribes the warnings and particulars to be given in respect of certain toys and categories of toys.



## Article 8

### Official inspection

1. The Member States shall ensure that products on the market are inspected to ascertain their conformity with the provisions of this Directive, and in particular with the common technical standards. The tests necessary to this end shall be carried out on the basis of the methods specified in this Directive as well as in the Directives provided for in Article 4(1) by the laboratories designated in accordance with Article 18.
2. In order to assess the safety of toys bearing the particulars specified in Article 5(1), the relevant authorities in the Member States may demand the technical report referred to in Article 5.
3. With a view to the possible application of the procedure referred to in Article 17, each Member State shall, three years after the date provided for in the second sub-paragraph of Article 20(1), forward to the other Member States and the Commission a report on the findings of the checks referred to in paragraph 1.

## Article 9

### Safeguard clause

1. Where a Member State has good grounds for considering that one or more toys, although complying with the provisions of Articles 4 to 7, in particular the common technical standards referred to in Article 4(1), represent a hazard to safety or health and therefore are not consistent with the general safety principle set out in Article 2, it may temporarily prohibit the marketing of these products in its territory or attach special conditions thereto. It shall immediately inform the other Member States and the Commission, stating in detail the grounds for its decision.



2. The Commission shall, within six weeks, consult the Member States concerned, following which it shall deliver its opinion without delay and take the appropriate steps.
3. If the Commission is of the opinion that technical amendments to this Directive are necessary, such amendments shall be adopted by either the Commission or the Council in accordance with the procedure laid down in Article 17. In that event, the Member State which has adopted safeguard measures may maintain them until entry into force of the amendments.

#### Article 10

##### Withdrawal of dangerous products from the market

Without prejudice to Community provisions on the withdrawal of products and, where no such provisions exist, to national legislation, the Member States shall take all necessary steps to ensure that their competent authorities promptly withdraw, or have withdrawn, from the market any toys which do not comply with the general safety principle enunciated in Article 2 and are therefore shown to be dangerous to the health and safety of consumers.

They shall inform the Commission and the other Member States of any market withdrawal measures as referred to in the previous paragraph.

#### Article 11

##### Protecting the rights of toy manufacturers, importers and vendors

Precise grounds shall be given for any individual measure taken under this Directive, in particular Articles 5, 8, 9 and 10, placing a restriction or ban on the introduction on the market or continued sale of toys or imposing any civil, administrative or other penalty. The parties concerned shall be notified of such measures together with details of their right of appeal and the time limit for the exercise of such rights.



## Article 12

### Consumer associations' right of initiative

Member States shall take the necessary steps to entitle consumer associations, upon submission of detailed grounds and with a view to the implementation of this Directive and of the Directives referred to in Article 4(1), to request the competent authorities of the Member States to verify the safety of certain toys on the market.

To this end, the associations may submit a technical report prepared by one of the bodies designated in accordance with the procedure described in Article 18.

## Article 13

### Advertising

Without prejudice to the Community Directives, and where no such Directives exist, to national legislation on misleading advertising, the Member States shall ensure that advertising of toys conforms to the following provisions:

- a) only toys conforming to the requirements of Article 2 may be advertised;
- b) advertisements must not mislead consumers concerning the capabilities needed to use the toy without danger and, having regard to the inexperience of children, must not give misleading information about the safety characteristics and performance of the toy;
- c) with regard to toys likely to present risks inherent in their use, the advertising must draw attention, if necessary by referring to the operating instructions, to the precautions to be observed by the user, and state whether supervision of the child while playing is necessary.



With respect to the toys referred to in Annex IV, 6(b) and 9(b), and in cases where the option provided for in the third subparagraph of Article 2(1) is applicable, express reference shall be made to the minimum age for use;

- d) all advertising or promotion of toys based on their safety or on the EEC symbol or the declaration provided for in Article 4 (3) and (4) shall be prohibited.

#### Article 14

##### Redress

1. Member States shall ensure that appropriate, effective, rapid and in-  
expensive means of redress shall be available, in the framework of national procedures, to any persons having suffered injury by using toys covered by this Directive.
2. In accordance with the legislation in force, Member States shall guarantee those concerned an appropriate right of appeal against measures  
as referred to in Article 11.

#### Article 15

##### Committee for the Directives on Toy Safety: powers

1. The amendments necessary for adapting to technical progress Annexes V and VI to this Directive and the Directives provided for in Article 4(1) shall be adopted in accordance with the procedure set out in Article 17.
2. The sampling methods, the methods for testing the common technical standards referred to in the third subparagraph of Article 4(1) and the amendments necessary for adapting these methods to technical progress shall be determined in accordance with the procedure set out in Article 17.



Article 16

Committee for the Directives on Toy Safety: establishment

1. A "Committee for the Directives on Toy Safety", hereinafter called "the Committee", is hereby set up. It shall consist of representatives of the Member States with a representative of the Commission as Chairman.
2. The Committee shall adopt its own rules of procedure.

Article 17

Committee for the Directives on Toy Safety: procedure

1. Where the procedure laid down in this Article is to be followed, matters shall be referred to the Committee by the Chairman, either on his own initiative or at the request of the representative of a Member State.
2. The representative of the Commission shall submit to the Committee a draft of the measures to be adopted. The Committee shall deliver its opinion on the draft within a time limit set by the Chairman depending on the urgency of the matter. Opinions shall be adopted by a majority of 41 votes, the votes of Member States being weighted as provided for in Article 148(2) of the Treaty. The Chairman shall not vote.
3. a) The Commission shall adopt the proposed measures when they are in accordance with the opinion of the Committee.

./.



- b) Where the proposed measures are not in accordance with the opinion of the Committee, or if no opinion is delivered, the Commission shall without delay propose to the Council the measures to be adopted. The Council shall act by a qualified majority.
- c) If, within three months of the proposal being submitted to it, the Council has not acted, the proposed measures shall be adopted by the Commission.

#### Article 18

##### Designation and notification of technical bodies provided for in the Directive

1. Each Member State shall designate the laboratories authorized to carry out the tests of conformity provided for in Articles 4(3) and 8 and draw up the technical reports provided for in Articles 5(2) and 12, and notify the other Member States and the Commission accordingly.
2. The laboratories referred to in paragraph 1 must fulfil the minimum conditions set out in Annex VIII.
3. The list of laboratories designated by each Member State shall be given adequate publicity at national level. It shall also be published, for information, in the Official Journal of the European Communities.
4. Each Member State shall inform the other Member States and the Commission without delay of any change concerning the laboratories referred to in paragraph 1. All such changes shall be publicized in accordance with paragraph 3.



Article 19

Information relating to accidents  
caused by toys

Subject to the application of the Community system for the rapid exchange of information on dangers arising from the use of consumer products and, in particular, with a view to the application of the procedure set out in Article 17, the Member States shall, at least every three years, communicate to the Commission any information relating to accidents in which toys were involved.

Article 20

Implementation

1. The Member States shall adopt and publish the provisions necessary to comply with this Directive and shall forthwith inform the Commission thereof.

They shall apply these provisions from 1 January 1983.

2. As soon as this Directive has been notified, Member States shall also ensure that the Commission is informed, in sufficient time for it to submit its comments, of any draft laws, regulations or administrative provisions which they intend to adopt in the field covered by this Directive.

Article 21

This Directive is addressed to the Member States.



## ILLUSTRATIVE LIST OF PRODUCTS TO BE REGARDED AS TOYS

(Article 1.1. 2nd indent)

1. Toys for babies and very young children (rattles, dummies etc.);
2. Crib toys (counting frames, mobiles, exercise bars, etc for cribs, baby walkers, playpens, prams and children's beds);
3. Games and toys to be assembled and/or for sense-training (blocks, cubes, rings, etc. to be stacked, assembled or fitted in, games with colours and figures, etc.);
4. Rocking animals and other rocking articles;
5. Bathtub toys (floating articles made of rubber or plastic, etc.);
6. Sand games and toys (shovels, buckets, barrows, etc.);
7. Pull and roll toys (rollers, carts, various vehicles to be pulled, etc.);
8. Soft toys, stuffed, made of plush, textiles, etc.;
9. Dolls and similar toys, also for very young children, and accessories (clothing, furniture, cribs, houses, etc.);
10. Miniatures (simple articles, cars, motorbikes, garages, etc.);
11. Musical toys;
12. Construction toys;
13. Parlour games, games calling for patience and thought, for children (cases containing games, cards and accessories, puzzles with patterns and consisting of no more than 500 pieces, etc.);
14. Building kits;
15. Toy weapons without projectiles;
16. Games and toys with projectiles (bows, rifles, etc.) and toy projectiles (darts for children, spears, boomerangs, etc.);
17. Mechanical and electrical toys (trains, car racing tracks, teleguided or radio-controlled cars and other articles, etc.);
18. Outdoor games (balls, balloons for children, hoops, pins, swings, slides, etc.);
19. Flying toys (kites, etc.);
20. Toy sports equipment;



- 21. Toys, in particular wheeled ones, intended to bear the weight of a child and to be propelled by the child (tricycles with or without pedals, scooters, cars with pedals, children's bicycles);
- 22. Sports toys requiring balance and skill (roller-skates, stilts, skate-boards, etc.);
- 23. Optical and acoustical toys (microscopes and accessories, children's viewfinders, kaleidoscopes, walkie-talkies, etc.);
- 24. Steam engines;
- 25. Imitation protective gear (glasses, helmets, etc.);
- 26. Panoplies (boxes, cases and sets for sewing, medicine, etc.);
- 27. Graphic games and toys (boxes of crayons, chalk, water colours, various paints for children, pencils, etc.);
- 28. Aquatic toys, within the meaning of the definition provided for in Annex IV.10, and toy crafts for children;
- 29. Functional toys within the meaning of Article 1.2 (sewing machines, various tool boxes, etc.);
- 30. Chemical games and toys, in particular those mentioned in Annex IV.9b).

10  
9  
8  
7  
6  
5  
4  
3  
2  
1

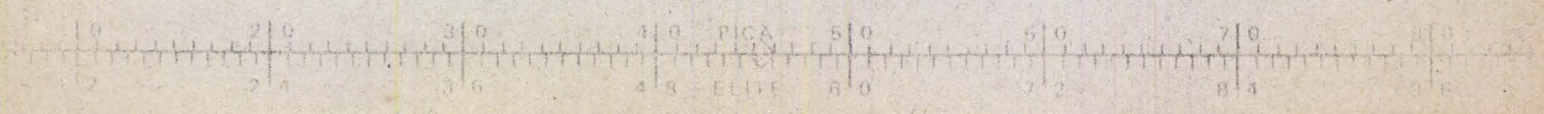



ANNEX II

PRODUCTS WHICH ARE NOT CONSIDERED AS TOYS FOR THE PURPOSE OF THIS DIRECTIVE  
(Article 1.1. 3rd indent)

1. Christmas decorations
2. Slings and catapults
3. Fireworks
4. Combustion engines for toys
5. Scaled-down models intended for adult collectors and manufactured according to scale in detail
6. Equipment intended to be used collectively in playgrounds
7. Sports equipment intended to be used for training purposes
8. Compressed-air weapons
9. Aquatic equipment intended to be used in deep water and flippers used for swimming
10. Folklore and decorative dolls and other similar articles for collectors
11. Practical jokes
12. Party novelties
13. Professional toys installed in public places (shopping centres, stations, etc)
14. Puzzles with more than 500 pieces or without pattern, intended for specialists
15. Video toys connected to television sets
16. Electric or electronic musical instruments for children
17. Electric toys, particularly functional ones, mains-operated and functioning at more than 24v

N.B.: - The articles referred to in points 1,2,7 and 12 are excluded from the scope of the Directive, unless they are offered for sale as toys or advertised as such: in that case, the provisions of the directive are to be applied.

- Member States take all necessary steps to ensure that the articles referred to in points 3,8 and 11 are not marketed as toys.

- The articles referred to in point 17 are temporarily excluded from the scope of the directive, subject to the directive concerning the electrical properties of toys, the preparation of which is provided for in Article 4.

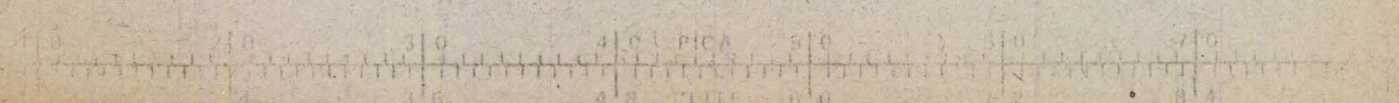



## GENERAL TOY SAFETY OBJECTIVES

(Article 2.1)

1. HAZARDS DUE TO MANUFACTURE OR COMPOSITION AND HAZARDS INHERENT TO THE USE

In accordance with Article 2, the health and safety of the child shall be protected

- a) against hazards due to the toy's manufacture and/or composition: the elimination of the hazards is reached by applying to the toy the technical safety specifications which are laid down in technical standards (Article 4);
- b) against hazards which are inherent to the use of the toy and cannot be eliminated by modifying the toy's manufacture and composition without altering its function or depriving it of its essential properties: such hazards are avoided or reduced through warnings and instructions for use and, in some cases, through an indication of the minimum age for use (Article 7).

2. HAZARDS OF A DIFFERENT NATURE

The hazards referred to in point 1 a) and b) take on - on the basis of the various properties which characterise the toys - different aspects which can be presented jointly and in a variable way by these products: in such cases, it is necessary to examine the conformity with Article 2 and to ensure it with regard to all safety aspects of the toy under consideration.

These risks of a different nature are mentioned in particular, along with the relevant general safety objectives in point 2.1 to 2.6.

The common technical standards in relation with these objectives are included in Annex V and VI, or will be established through the directives provided for in Article 4, paragraph 1.

./.



2.1 Physical and mechanical properties

In this connection, it is in particular necessary to eliminate or avoid

- the risks - covered by the common technical standards provided for in Annex V - of injuries, falls, burns, suffocation, etc. and of impairing the child's physical health in any way as a consequence of the toys' physical and mechanical characteristics;
- risks of drowning which can be caused by aquatic toys, children's crafts and other articles of this type, as well as those which involve the child's sight or hearing and can be caused by certain toys: it will be possible to prepare technical standards especially for these toys, in accordance with Article 4, paragraph 1.

2.2 Flammability

Toys may not constitute a dangerous flammable element in the child's environment.

Therefore, they must be

- either non-flammable: they should not burn if directly exposed to a flame;
- or made of materials which are not readily flammable or have technical specifications which make them virtually so (self-extinguishing): the flame goes out as soon as the heat source is removed;
- or made of materials which, if they do ignite, burn slowly and present a low rate of spread of the flame, or which are treated - subject to the general safety objectives and the common technical standards relating to the toy's chemical composition - in such a way as to delay the combustion process.

The toys' ignition hazards are subjected to the technical specifications and warnings provided for in Annex VI.

6  
5  
4  
3  
2  
1

./.

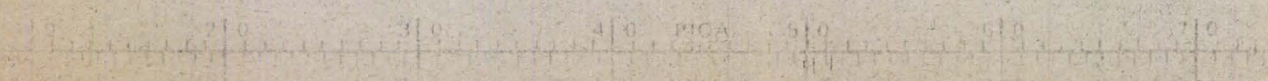



### 2.3 Chemical properties

Toys must be designed and produced in such a way as to avoid risks which may derive from the chemical properties of the materials, substances and preparations of which they are made.

This concerns in particular risks of acute and chronic poisoning, of corrosive or irritant action and carcinogenic risks which can arise as a consequence of ingestion, inhalation or contact with the skin, the mucous membranes and the eyes of toxic, harmful, corrosive or mutagenic elements or components which may be present in the toy.

Therefore, the general safety objectives below must be pursued.

- A. Toys which include in their composition substances and preparations which are regarded as dangerous within the meaning of directive 67/548/EEC (1) of 29 June 1967 may not release toxic elements through ingestion or contact in a quantity likely to present a danger to the child.

This rule applies in particular to the toys which are intended to be kept in contact with the skin or which comprise a coating of paint, lacquer, varnish or similar substances, to graphic toys, toys made of plastic, textiles or any other material which are likely to entail the hazards referred to in this paragraph, unless these toys by reason of their function, size and other demonstrable characteristics, obviously exclude any chance of ingestion or irritation through contact.

- B. Toys may not contain, as such, the dangerous substances and preparations referred to under A. at levels of concentration or in a form likely to harm the health of a child through

./.

---

(1) Council Directive on the approximation of the laws of the Member States relating to classification, packaging and labelling of dangerous substances (O.J. 161/1 of 16.8.67), and particularly Directive 79/831/EEC of 18 September 1979 (O.J. L 259/10, 15.10.79), Article 2.2, paragraphs f) to n).



contact or inhalation. If, however, it is not possible in the case of certain toys to use substances or preparations which exhibit such levels of concentration without thereby changing the basic function or characteristics of the toys, higher levels shall as an exception be permitted where this is absolutely vital, provided that precise indications are given regarding the dangers presented by these toys and the precautions which are to be followed.

The risks of accidentally ingesting such substances and preparations must always be subjected to a specific indication, whatever their level of concentration may be.

The above rules apply in particular to toys containing children's paints, specifically finger paints, glues and solvents, inks, cosmetics, detergents and other household products as well as chemical toys.

C. Toys may not include in their composition or contain as such the substances and preparations whose use is prohibited or limited by Community Directives (1). This prohibition is applicable according to the procedures provided for by these Directives.

D. Pending adoption of the directive provided for in Article 4, paragraph 1 and, in relation with chemical risks, - toys intended for children below 36 months of age and those intended to be put to the mouth or to contain foodstuffs must comply, as regards their composition, with Community directives (2) or, in their absence, with national regulations

./.

---

(1) In particular dir. 76/769/EEC of 27 July 1976 (O.J. L 262/201 of 27.9.76) and dir. 79/663/EEC of 24 July 1979 (O.J. L 197 of 3.8.79).

(2) In particular dir. 76/893/EEC of 23 November 1976 (O.J. L 340/19 of 9.12.76) and dir. 78/142/EEC of 30 January 1978 (O.J. L 44/15 of 15.2.78).

7  
6  
5  
4  
3  
2  
1

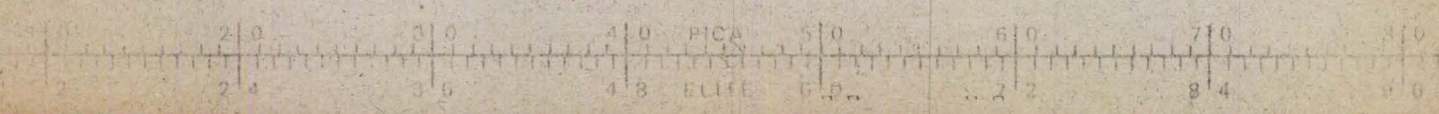



relating to materials coming into contact with foodstuffs. Furthermore, they may not contain, as such, the dangerous substances and preparations referred to in A, whatever their level of concentration may be;

- Community directives concerning the safety of consumer goods, such as the Directive relating to cosmetic products (1), are also applicable to toys containing such products or imitations of these products.

2.4 Risk of explosion

In this connection, the safety objectives below are to be pursued.

- a) toys must not be explosive or contain elements or parts likely to explode (e.g. aerosols);
- b) the risks of explosion and bursting caused by the overcompression of liquids or gases which permit the functioning of certain toys such as steam engines must be avoided (see Annex V, 3.9.2);
- c) toys may not contain as such and in any dangerous form or level of concentration the substances and preparations listed as potentially explosive in Article 2.2a) of Directive 67/548/EEC of 27 June 1967, and those which may explode on contact with flame or when subjected to shock or friction;
- d) toys, and in particular chemical games and toys must not contain substances or preparations which, when mixed, may cause an explosion.

./.

---

(1) Dir. 76/768/EEC of 27 July 1976 (O.J. L 262/169 of 27.9.76)

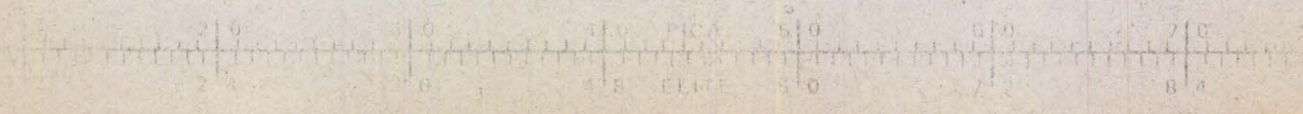



2.5 Electrical properties

Without prejudice to the exclusion provided for in Annex II, point 12, toys must be conceived and manufactured in such a way as to avoid risks due to their construction and inherent to their use, which may arise from their electrical properties.

This concerns particularly risks of burns caused by the toy overheating, and risks of electrical shocks arising from the power, the insulation of the toy, the resistance to moisture and rust of certain parts, etc.

2.6 Hygiene

Toys must be manufactured and offered for sale in such a state that any risk of infection, illness or irritation likely to arise from unsatisfactory conditions of hygiene and cleanliness is avoided.

This principle applies particularly to toys intended for children under three years of age, toys made of textiles or paper, those used for disguise or which contain padding.

2.7 Radioactivity

Toys must not contain radioactive elements or substances in forms or proportions likely to be detrimental to the child's health.

10  
9  
8  
7  
6  
5  
4  
3  
2  
1

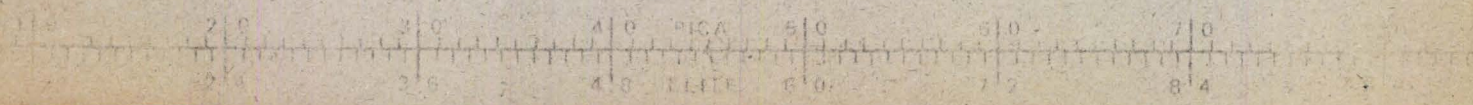



ANNEX IV

WARNINGS AND INDICATIONS ON THE INSTRUCTIONS FOR USE  
(Article 7, 2nd paragraph)

1. Toys which may not be intended for children under 36 months

Toys which might be dangerous for children under 36 months of age shall be marked 'NOT SUITABLE FOR CHILDREN UNDER 36 MONTHS OF AGE', followed by a brief indication, which may also appear in the instructions, of the risks calling for this restriction (e.g. flammability, toxicity, falls, etc.).

This provision does not apply to toys which, on account of their function, dimensions, characteristics or properties, are not likely to be given to children under 36 months of age.

2. Sharp points and cutting edges serving a functional purpose

Toys which incorporate cutting edges or points serving a functional purpose shall be accompanied by instructions or any other marking which shall draw attention to the potential hazards of such points and edges.

3. Suspended swings and rings, trapezes, ropes, etc. attached to a cross-beam

Such toys shall be accompanied by instructions which shall draw attention to the need to periodically carry out checks and assure the maintenance of their major posts (suspensions, fastenings, fixing to the ground, etc.) and which shall point out that in case of failure to make these checks, the toy may present dangers of falls or overturning.

Instructions must also be given concerning the correct way of assembling them and indicating those parts which can present dangers if it is not correctly assembled.

4. Functional Toys

Functional toys shall bear the marking 'WARNING: USE UNDER THE DIRECT SUPERVISION OF AN ADULT'.

./.

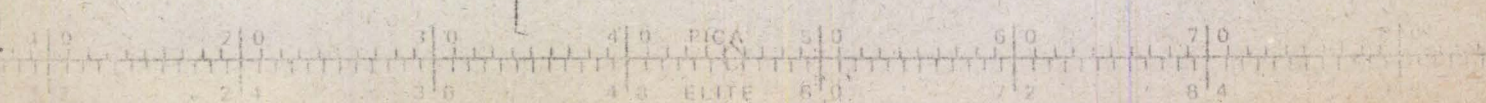



In addition, these toys shall be accompanied by directions giving working instructions, as well as the precautions to be taken by the user, with the warning that failure to take these precautions would expose the user to the hazards - to be pointed out - normally associated with the appliance of which the toy is a scale model or an imitation.

It will also be indicated that the toy must be kept out of the reach of very young children.

5. Steam engines and other steam toys - Fuels

- a) Such toys, or their packaging, shall bear the marking 'WARNING: USE ONLY UNDER THE SUPERVISION OF AN ADULT'.

They shall be accompanied by instructions or by a statement set out on the packaging explaining how the toy operates as well as the precautions to be taken by the user, with an indication that failure to take these precautions would expose the user to the hazards which are normally associated with the particular engine, which are described briefly (e.g. burns, fire hazard, explosions under high pressure).

It will also be indicated that the toy must be kept out of the reach of very young children.

- b) In addition, should any liquid or solid fuel be sold with the toy or separately, the attention of the user must be drawn to the hazards associated with the storage or use of the fuel. The marking 'FLAMMABLE' must appear on the packaging of the toy or the fuel.

This provision shall also apply to toys other than steam engines which involve the use of fuel.



6. Toys with projectiles or toy-projectiles

- a) Toys with projectiles whose kinetic energy does not exceed 0.5 J shall be accompanied by a marking, which may appear in the instructions for use, drawing attention to the hazards of using missiles other than those supplied by or recommended by the manufacturer, and to the danger of firing the projectiles at point-blank range.
  
- b) Pigeon shooting, ball-trap and similar games which use rifles or spring pistols having projectiles that have tips of rubber or some other elastic material, and whose kinetic energy exceeds 0.5 J shall bear the marking: 'WARNING: FOR CHILDREN OVER 8 YEARS OF AGE ONLY. TO BE USED UNDER THE SUPERVISION OF AN ADULT'. In addition, the instructions shall draw attention to the fact that rifles and pistols must be aimed solely at the target provided in the game and indicate that any other use of the toy could cause wounds.

It should also be noted that such games must be kept out of the reach of very young children.

- c) Toy projectiles (e.g. boomerangs) require instructions drawing the attention on the particular hazards inherent to the use of that toy.

7. Facsimile protective equipment and spectacles

Facsimile protective equipment, especially headgear (e.g. crash-helmets), shall bear the marking "WARNING: THIS TOY IS NOT PROTECTIVE EQUIPMENT". For facsimile spectacles this indication may be placed on the packaging.

8. Kites and other flying toys

Kites or other flying toys shall bear the marking: 'WARNING: DO NOT USE NEAR OVERHEAD POWER LINES. DANGER OF ELECTROCUTION'.

./.



9. Games and toys containing inherently dangerous substances, preparations or materials (e.g. solvents, acids, adhesives, etc.).

Chemical toys

- a. Subject to the provisions laid down in Community Directives on the classification, packaging, labelling of dangerous substances and preparations, the packaging or instructions for use of games or toys containing inherently dangerous substances, preparations or materials, shall bear a marking or warning of the dangerous properties of these substances, preparations and materials and of the precautions to be taken by the user in order to avoid the hazards which are associated with them and shall be listed in a concise way according to the type of toy, and namely the ingestion hazards. The instructions will also stress the necessity of keeping such toys out of the reach of very young children.
  
- b. In addition to the instructions provided for in a), chemical toys and games which contain the substances, preparations and materials mentioned above shall bear the following marking on their packaging: 'WARNING: FOR CHILDREN OVER 10 YEARS OF AGE ONLY. USE UNDER THE SUPERVISION OF AN ADULT'.

If the substances and preparations contained in such toys are likely to change or to lose, after a certain time, their specific safety properties, the instructions shall give the necessary indications or the expiry date of these substances.

In particular the following are considered: chemical toys and games, chemistry sets, plastic embedding sets, miniature work-shops for ceramics, enamelling, photography, and similar toys.



10. Aquatic toys

Aquatic toys and their packaging shall bear the marking:

'WARNING: USE ONLY IN SHALLOW WATER AND UNDER SUPERVISION'

Swimming accessories representing facsimiles of individual life-saving apparatus and their packaging shall bear the marking mentioned in the preceding paragraphs with the following addition:

'THIS TOY IS NOT A LIFE-SAVING APPARATUS'.

The markings above are to be applied for inflatable aquatic toys, at a point close to the air valve.

In addition, the instructions for use shall contain precise indications particularly on the maintenance and storage of the toy, and for inflatable toys, the procedure for inflating, as well as a reference to the warnings appearing on the toy and on its packaging, with the additional warning to the user that, in case of failure to take these precautions, the user runs the risk of drowning.

For the purpose of this provision, and subject to the directive provided for in article 4.1, 3rd paragraph, 2nd dash, concerning these toys, aquatic toys are inflatable or non-inflatable objects designed to be used by children as an article of play and only under the direct supervision of an adult, in shallow water and in particular facsimile swimming accessories for children, and facsimile personal life-saving apparatus as well as large rubber balls and other floating objects which can be gripped. Aquatic toys shall not be taken to include toys designed to be used in bathtubs, toy-craft for children and other floating articles capable of supporting a child entirely above the water, such as air-mattresses, rafts, etc.

./.



11. Toy skate-boards

These toys shall bear the marking: 'WARNING: USE ONLY WITH PROTECTIVE EQUIPMENT'.

In addition, the instructions for use shall remind the user that the toy must be used with extreme care as it requires much skill, and away from public thoroughfares, to avoid accidents which may result from falls or from collisions of the user and some third party. Indications on the protective equipment (helmets, gloves, knee-guards, elbow-guards, etc.) shall also be given.

12. Disguise costumes. Toys intended to be entered by a child. Beards, moustaches, wigs and masks.

In the cases provided for in Annex VI, these toys will bear the marking: 'WARNING: KEEP AWAY FROM FIRE'.



COMMON TECHNICAL STANDARDS AND METHODS OF TEST  
FOR MECHANICAL AND PHYSICAL PROPERTIES OF TOYS

52

1. FIELD OF APPLICATION

This annex sets out:

a) the general requirements for physical and mechanical properties and those concerning the materials used and the construction of the toys (§§ 2.1 to 2.2.9):

- Materials: sheets of flexible plastic, wood, glass and stuffing materials.
- Construction: edges, overlap joints, fastenings, metal points and wires, tubes and similar rigid components, folding mechanisms, hinges, driving mechanisms and springs.

b) The specific construction requirements for mechanical and physical properties, applicable to the following types of toys (§§ 3 to 3.14):

- Small toys and detachable components;
- Non-detachable components;
- Toys intended to be put to the mouth;
- Toys intended to be used in a cradle, cot or perambulator;
- Toys intended to be pulled along by the child;
- Toys which a child can enter;
- Toys intended to bear the weight of a child;
- Heavy immobile toys;
- Toys containing a heat source including steam engines;
- Toy projectiles and toys with projectiles;
- Non-projectile facsimile weapons.
- Facsimile protective equipment;
- Rattles;
- Kites and other flying toys.

./.



c) The methods of test for the requirements specified under a) and b) (§§ 4 to 4.16).

d) The requirements for mechanical and physical properties applicable to the packaging of toys (bags made of flexible plastics) and their methods of test (§ 5).

2. GENERAL REQUIREMENTS

2.1 MATERIALS

2.1.1 Flexible plastic sheeting

Sheets of flexible plastics without any backing (for example, used for making aprons), of an area greater than 100 mm shall have a minimum thickness of 0.038 mm.

2.1.2 Wood

Wood shall not display any insect holes and no knots shall be loose.

Bark may be used only in the manufacture of folklore toys (i.e. for decorative purposes). This requirement does not apply to cork.

The surface of wooden toys shall not be rough to such an extent that risk of injury from splinters may result.

2.1.3 Glass

Glass shall not be used in the construction of toys for children under 36 months with the exception of balls for rattles and eyes for dolls, animals, etc.

10  
9  
8  
7  
6  
5  
4  
3  
2  
1

./.

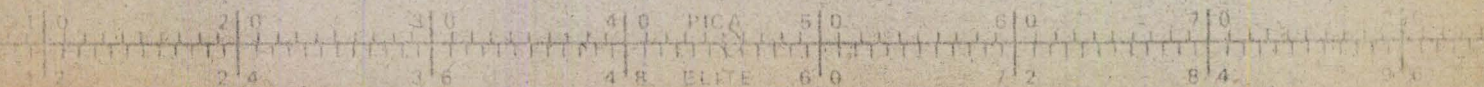



Glass may be used in the construction of toys for children over 36 months only where its use is necessary to the function of the toys (for example, optical toys).

Scientific kits and scale models also may contain small glass vessels. However, where such vessels are intended to be exposed to heat, only borosilicate glass shall be used.

Where glass is used, its edges shall be rounded and, if necessary, protected. This does not apply to microscope slides and cover slips.

2.1.4 Stuffing materials

Stuffing materials shall not contain any hard or sharp objects, such as scrap metal, nails, needles, and splinters of wood, glass or plastics.

If such materials consist of granules they must be enclosed in an internal casing, which is not the external covering and is sufficiently strong to prevent them escaping from the toy during its use.

2.2 CONSTRUCTION

2.2.1 Edges

The accessible edges of toys shall be designed so as to avoid risk of injury, and in particular, they must be free of burrs which are likely to cause injuries.

./.

10  
9  
8  
7  
6  
5  
4  
3  
2  
1

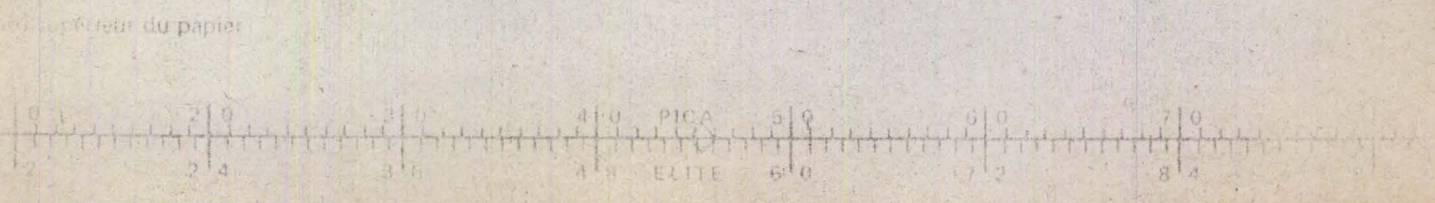



For metal sheets with a thickness of less than 0.5 mm, the following means are deemed to meet that requirement:

a) the edges may be folded, rolled or spiralled (see figures).

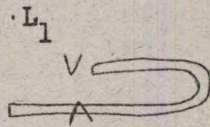

Folded edge, less than 270°

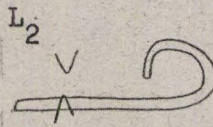

Rolled edge, between 270° and 360°

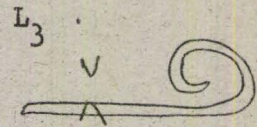

Spiralled edge, more than 360°

L1 = 0.5 mm maximum L2 = 1.5 mm maximum No limit specified for L3

b) The edges may be protected by a plastic coating or by paint.

Functional cutting edges are permitted only for toys intended for children over 36 months; in such a case, the attention of the users must be drawn to the dangers these edges present (see annex IV.2).

Within the meaning of the previous paragraph, functional cutting edges are the edges of pieces intended to be used as electrical conductors (i.e. wedges connecting the railroad tracks of electrical trains).

2.2.2 Overlap joints

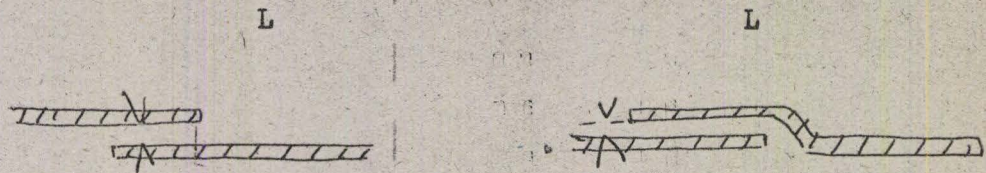

When the clearance L between the sheet metal and the underlying surface is greater than 0.7 mm, the edge of the sheet metal shall comply with 2.2.1.

10  
9  
8  
7  
6  
5  
4  
3  
2  
1

./.

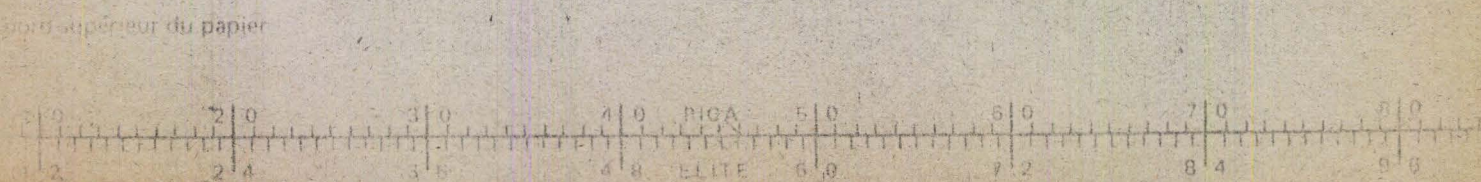



2.2.3 Fastenings

The pointed ends of screws, nails and similar fastenings used in the manufacture of toys shall not be accessible.

Accessible parts of fastenings shall be free from burrs.

If a fastening is intended to be countersunk, no part of the head shall protrude above the surface of the finished toy.

These requirements apply before and after any tests specified in this standard for the toy under consideration.

2.2.4 Metal points and wires

Toys shall not have accessible points sharp enough to inflict an injury.

This requirement does not apply to points which are essential for the functioning or design of toys intended for children over 36 months. The potential dangers presented by such points shall be drawn to the attention of users (see Annex IV.2.).

Joints which could become accessible shall be protected in an adequate way.

The wires forming part of the toy and which can become accessible shall have ends which are protected in an adequate way (e.g. curled or swollen into a ball or oval). Wires likely to be bent by the child shall not break when tested in accordance with § 4.1.

./.

10  
9  
8  
7  
6  
5  
4  
3  
2  
1

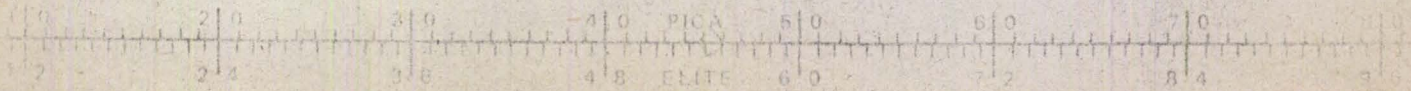







2.2.8 Driving mechanisms

Driving mechanisms (such as gears, belts, winding mechanisms, whether driven electrically, by friction or clockwork, but excluding such mechanisms when they form part of a construction toy or a toy referred to in §3.7) forming an integral part of a toy shall be made so that moving parts - likely to jam the fingers or otherwise injure a child - cannot become accessible.

When toys with such mechanisms are tested in accordance with § 4.3, the mechanism shall not become exposed.

The shape and dimensions of winder keys or starting handles shall be such that the clear space between the key or the handle and the body of the toy is less than 2 mm or greater than 12 mm.

If starting cords less than 1.5 mm in diameter are used for mechanisms in toys for children under 36 months, the recoil force of the mechanism shall not exceed 4.5 N.

2.2.9 Springs

Springs shall be protected if, during use of the toy, the spring might trap the fingers of a child or injure it in any way.

In the case of spiral springs, protection shall be provided if the gap between two consecutive spirals is greater than 3 mm, when the spring is at rest.

In the case of helix springs, protection shall be provided if the gap between two consecutive turns is greater than or equal to 3 mm, when the spring is subjected to a tensile force of 40 N.

10  
9  
8  
7  
6  
5  
4  
3  
2  
1

./.

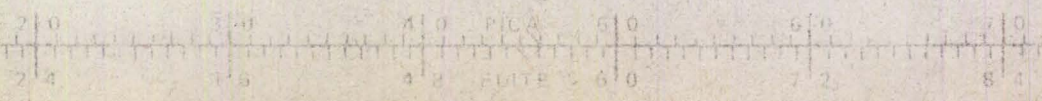



3. SPECIFIC CONSTRUCTION REQUIREMENTS APPLICABLE TO CERTAIN TYPES OF TOYS

3.1 Small toys and detachable components

The largest dimension of toys and of detachable components of toys intended for children under 36 months shall not be less than 32 mm; the test applicable to this provision is provided for in §4.16.

3.2 Non-detachable components

In the case of toys for children under 36 months to which components made from glass, metal, wood or other non-pliable materials are attached, these components shall either:

- be embedded so that the child cannot grab them with his teeth or fingers;
- or be fixed to the toy so that they cannot become detached or loosened when they are submitted to:
  - a force of 50 N when the largest accessible dimension is less than or equal to 6 mm;
  - a force of 90 N when the largest accessible dimension is greater than 6 mm.

For the application of the present provision, soft toys (dolls, animals, etc.) are considered as toys intended for children under 36 months.

3.3 Toys intended to be put to the mouth

Toys intended to be put to the mouth (e.g. whistles) and which contain reeds, balls or similar components shall be so constructed as to prevent these components escaping from the toy if they become detached, when a sucking pressure of 0.1 bar is applied throughout the toy, this sucking pressure being applied to the orifices likely to be put to the mouth.

./.

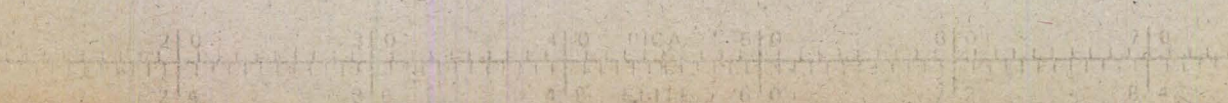



3.4 Toys for cradles, cots or perambulators

To avoid any danger of strangulation or wounds due to rebounding, the free length of cords of toys intended for cradles, cots and perambulators shall not exceed 300 mm. This requirement applies to elastic cords when they are subjected to a force of 25 N. The above requirement does not apply to elastic cords fixed on both sides of the cradle, cot or perambulator. Such elastic cords when subjected to a force of 25 N shall not exceed 750 mm in length and their length under these conditions shall not be more than 40 percent longer than their relaxed length.

3.5 Toys intended to be pulled along by the child

To avoid any danger of strangulation, cords of toys intended to be pulled along shall not include slip knots or fastenings likely to form a slip knot. Cords of such toys for children under 36 months shall be not less than 1.5 mm thick.

3.6 Toys which a child can enter

To avoid any risk of suffocation in the case of toys large enough to contain a child and having a door, lid or similar closing device, it shall be possible for a child to open the door, lid or similar device from the inside.

When the doors, lids and similar devices are closed, ventilation shall be ensured.

3.7 Toys intended to bear the weight of a child

3.7.1 Toys propelled by and intended to bear the weight of a child (e.g. tricycles, scooters, cars) shall comply with the following requirements:

./.



- a) the toy, when tested in accordance with § 4.4 and 4.5, shall not break and shall still comply with the requirements of this standard;
- b) the toy, when tested in accordance with § 4.6, shall not tip over. This requirement does not apply to toys with two aligned wheels (e.g. scooters, bicycles even when provided with stabilizers);
- c) mechanically propelled (e.g. chain driven) toys with a free wheeling facility shall have a braking device which shall be such that when the toy is tested in accordance with § 4.7, the toy shall not move.
- d) the driving chains shall have on the side where the leg of the child skims the chain, a protective element going from the crank-gear to the sprocket, and, on the other side, a protective element on the level of the crank-gear (see sketch);

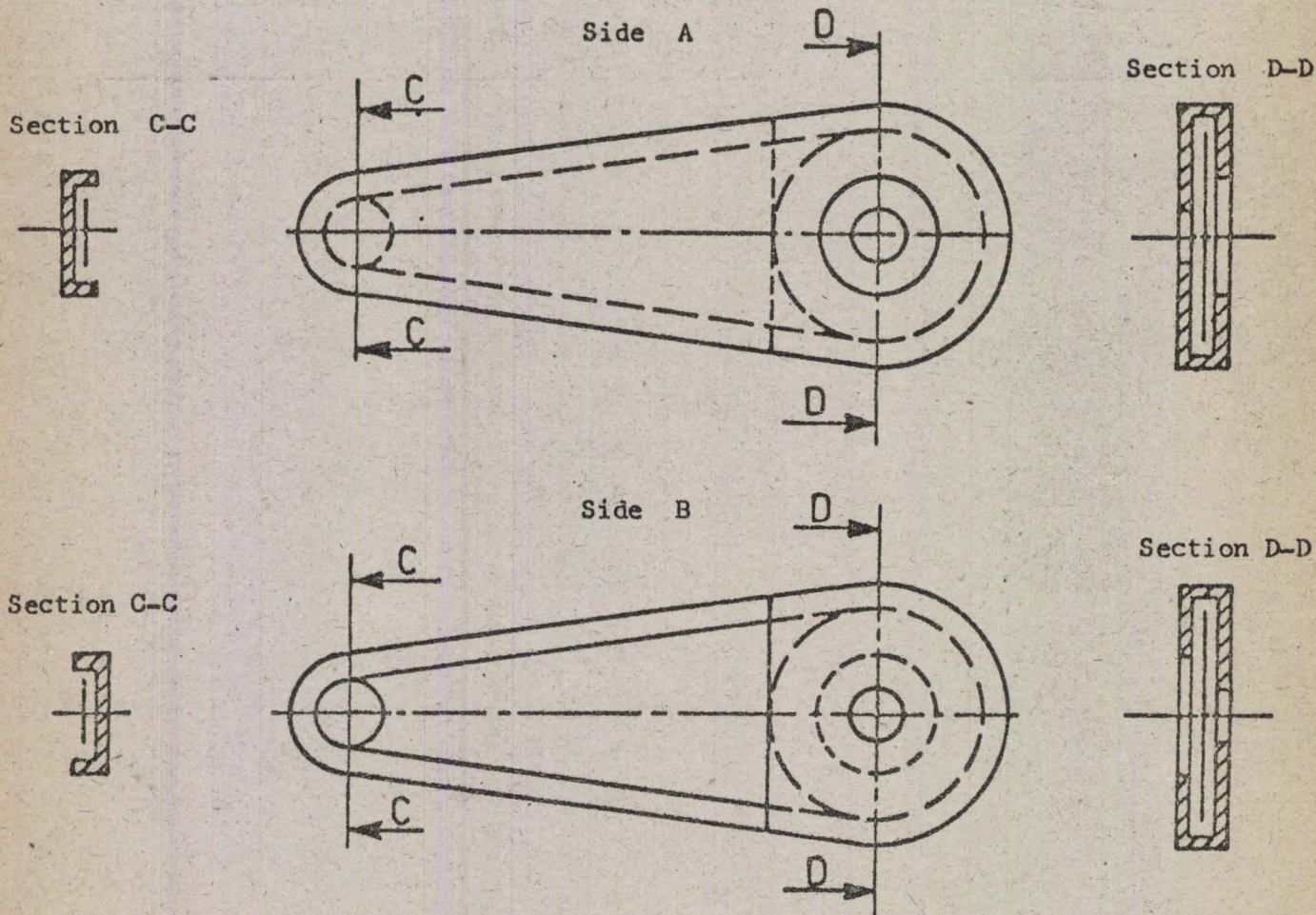

Side A = Side where the leg of the child skims the chain  
Side B = Side opposite to A



Both parts of the chainguard (side A + B) shall be fixed together so as to form one block which a child will remove with difficulty.

The part of the crank-gear on side A which is not covered by the chain-guard shall not have any slots in which the child can put its fingers;

- e) wheels propelled directly by pedals shall be solid, but slots or holes of a width of 5 mm or less may be made in them;
- f) spaces between wheels and the body or parts of the toy (e.g. mudguards) shall be less than 5 mm or more than 12 mm.

3.7.2 Toys not propelled by but intended to bear the weight of a child (e.g. rocking horses, garden slides, see-saws) but excluding swings shall comply with the following requirements:

- a) the toy, when tested in accordance with § 4.4, shall not break and shall still comply with the requirements of this standard;
- b) the toy, when tested in accordance with § 4.6, shall not tip over. This requirement does not apply to toys with a device for fixing them to the ground (for example: garden slides);
- c) for outdoor toys, means shall be provided to ensure that water that might otherwise accumulate inside the toy is constantly able to drain away.

### 3.7.3 Swings

Swings shall comply with the following requirements:

- a) swings, when tested in accordance with § 4.8, shall not break and shall still comply with the relevant requirements of this Annex;

./.



- b) the means of suspension (e.g. ropes, chains) shall have a minimum average diameter of 10 mm. Suspension hooks shall be wound over at least 540°;
- c) the following safety devices are considered appropriate to prevent the child from falling off the seat:
  - a protective bar situated between 200 mm and 300 mm above the seat,
  - a device to fasten the child to the seat;
- d) in accordance with Annex IV.3, the need for regular checks and upkeep of the suspension system shall be drawn to the attention of users.

3.8 Heavy immobile toys

Immobile toys weighing more than 5 kg and intended to rest on the floor but not to bear the weight of a child, shall not tip over when tested in accordance with § 4.9.

3.9 Toys containing a heat source

Toys containing a heat source shall not catch fire during continuous operation.

3.9.1 The rise in temperature of parts which are intended to be touched by the hand, for example handles, knobs, controls, grips, etc., shall not exceed the following values when tested in accordance with § 4.10:

metal .....	25 K
glass, subject to application of § 2.1.3 ..	30 K
plastics, wood .....	35 K

The rise in temperature of the other parts of the toy shall not exceed the following values:

metal .....	45 K
other materials .....	55 K

./.



### 3.9.2 Steam engines

Steam engines must comply with the following requirements:

- a) For the requirements concerning the rise in temperature of parts which are intended to be touched by the hand, the values of § 3.9.1 apply when the steam engine is tested in accordance with § 3.10.
- b) The furnace shall have a safety device to prevent the introduction of fingers when the toy is operating. The closure of the furnace shall have a handle.

If the engine operates with liquid fuel, the burner shall be so constructed that during the test specified in § 4.11.1 the liquid shall not escape except as drop by drop.

If the engine operates with solid fuel, the fuel shall not escape from the furnace during the test specified in § 4.11.1.

Liquid and solid fuel for steam engines, sold with the toy or separately, shall bear a warning on its packaging drawing attention to the hazards which stocking and using such fuels may present for a child (see Annex IV.5b)).

- c) The capacity of boilers shall not exceed 2000 cm<sup>3</sup>. The boiler shall be provided with at least one safety valve which cannot be adjusted by the user (e.g. a spring valve) made of rust resisting material. Weighted safety valves shall not be used.

Steam engines shall either be provided with a device which gives the user an indication of the water level in the boiler (e.g. a water level indicator), or they shall be designed in such a way as to prevent the boiler being filled above the level specified by the manufacturer (e.g.: an overflow).

./.



When tested in accordance with § 4.11.2 the service pressure shall not exceed 1.5 bar. The service pressure is the steam pressure produced within the boiler after starting the engine running on no load. The release pressure of the safety valve shall not exceed twice the service pressure. The bursting pressure of the boiler shall be at least three times the service pressure, without being less than twice the release pressure of the safety valve.

The dimensions of the fuel tank shall be such that, when the steam engine is tested in accordance with § 4.11.2 not more than 80 percent of the contents of the boiler shall evaporate.

The potential dangers presented by steam engines shall be drawn to the attention of users, according to Annex IV.5 a).

### 3.10 Toy projectiles and toys with projectiles

3.10.1 In the case of toys with projectiles where the kinetic energy is determined by the characteristics of the toy and not by the child, this kinetic energy when tested in accordance with § 4.12 shall not exceed 0.5 J.

In the case of these toys, the potential dangers of using other missiles than those accompanying the toy and of firing the projectile at point blank range shall be drawn to the attention of users (see Annex IV.6a)).

3.10.2 Pigeon-shooting, ball-traps and similar toys using spring-loaded guns and pistols with projectiles, the tip of which is made of rubber or another flexible material and having a kinetic energy which exceeds 0.5 J, carry the indications foreseen in Annex IV. 6b).



3.10.3 Projectiles in the form of arrows for spring loaded guns and pistols, cross-bows, long bows and pea-shooters shall not be made of metal.

Their ends shall be blunted and their heads protected by a flexible tip, the diameter of which is at least equal to the greater of the following two values:

- 20 mm or
- 3 times the maximum cross-sectional dimension of the body of the arrow.

The tip shall not become detached when subjected to a tensile force of 50 N.

3.10.4 The points of darts for children shall not be made of metal; points fitted with magnetic discs are permitted.

Toy projectiles (e.g. boomerangs) carry the indication foreseen in Annex IV.6c).

### 3.11 Non-projectile facsimile weapons

Non-projectile facsimile weapons (e.g. knives, swords, axes) shall not have functional edges or points which could inflict injuries.

### 3.12 Facsimile protective equipment

Transparent parts of facsimile protective equipment (e.g. spectacles, masks) shall not crack when tested in accordance with § 4.13.

Facsimile protective helmets (e.g. motorcycle helmets, industrial safety helmets) and spectacles shall bear a marking to draw attention to the fact that they offer no protection (see Annex IV.7).

./.



3.13 Rattles

The solid particles placed inside rattles for babies and other similar toys shall be smooth and rounded. Glass balls are permitted.

Seeds and materials, the dimensions of which increase by more than 5 per cent when tested in accordance with § 4.14, shall not be used.

When the toy is tested first in accordance with § 4.3 and then § 4.15, the casing containing the particles shall not break. The last indent of § 2.2.4 is applicable, where appropriate.

3.14 Kites and other flying toys

Strings longer than 3 m, for kites and other flying toys, shall be made of non-metallic material.

The potential danger of flying a kite near overhead power lines shall be drawn to the attention (see Annex IV.8).

4. METHODS OF TEST

Unless otherwise specified in Chapters 2 and 3, compliance with the requirements of this standard is checked by visual inspection and measurement of distances, gaps, pull forces etc., as appropriate.

4.1 Flexibility of wires (see § 2.2.4)

The wire is held firm by two metal cylinders each of diameter 10 mm. The wire is bent from the upright to one side through 60° and then bent in the opposite direction through 120° and finally returned to the upright position (one cycle). The test is carried out 30 times at a rate of one cycle per second, with a rest of 20 seconds after each 10 cycles.

Examine whether the wire breaks.

./.



4.2 Reaction of protective components to traction (see § 2.2.5)

The part to be tested is subjected to a tensile force determined by the weight of the toy or 60 N, whichever is greater.

Examine whether the part becomes detached from the toy.

4.3 Drop strength (see § 2.2.8, 2.2.4 and 3.13)

The toy is dropped five times from a height of  $85 \pm 5$  cm. on to a 4 mm thick steel plate, which has a 4 mm thick coating of Shore A hardness  $75 \pm 5$  and which is placed on a non-flexible horizontal surface.

Examine whether the mechanism has become exposed, or, for rattles, whether the casing has been damaged.

4.4 Static strength (see § 3.7.1 and 3.7.2)

The toy is loaded either on its standing or sitting surface, with a mass of 50 kg for 5 min.

After removing the load, examine whether any part of the toy is broken and whether the toy still complies with the relevant requirements of this Annex.

4.5 Dynamic strength (see § 3.7.1)

The wheeled toy propelled by the child is loaded with a mass of 50 kg, the centre of gravity of which is 150 mm above the surface on which the child sits or 400 mm above the surface on which the child stands. In both cases the experimental load shall be placed so that the forces which act at the positions correspond to the normal use of the toy. The toy is then driven three times against a 50 mm high non-resilient step at a speed of 2 m/s.

After removing the load, examine whether any part of the toy is broken and whether the toy still complies with the relevant requirements of this Annex.

./.



4.6 Stability (see § 3.7.1 and § 3.7.2)

The toy is loaded as in § 4.5 and placed in any position on a plane inclined at  $10^{\circ}$ .

Examine whether the toy tips over.

4.7 Braking (see § 3.7.1)

The toy, loaded as in § 4.5, is placed on a plane inclined at  $10^{\circ}$  with its longitudinal axis parallel to the incline. A force of 50 N is applied to the control of the braking device.

Examine whether the toy moves.

If the brake is operated by a handle, the force of 50 N is exerted at right angles to the axis of the handle, at the middle of the handle, and using the handle-bar as a support.

If the brake is operated by a pedal, the force of 50 N is applied in the operating direction producing the brake.

If the vehicle has several brakes each brake is tested separately.

4.8 Strength of swings (see § 3.7.3)

The toy is loaded uniformly for 1 h on its standing or sitting surface with a mass of 200 kg.

After removing the load, examine whether any part of the toy is broken and whether it still complies with the relevant requirements of this Annex.

4.9 Stability of heavy toys (see § 3.8)

The toy is placed in any position on its base on a plane inclined at  $5^{\circ}$ , whereby all moving parts are adjusted so as to produce the most unfavourable position for stability.

Examine whether the toy tips over.

./.



4.10 Temperature rises (see § 3.9.1 and 3.9.2 a))

In an ambient temperature of  $25^{\circ} \pm 3^{\circ}\text{C}$ , operate the toy in accordance with the instructions using the maximum quantity of fuel or, in the case of an electric toy, the maximum input, until equilibrium temperature is reached.

Measure the temperature of the parts and calculate the temperature rises.

Examine whether the toy ignites.

4.11 Steam engines

4.11.1 Burner (see § 3.9.2 b))

In the case of steam engines using liquid fuel, remove the burner, fill it in accordance with manufacturer's instructions, tip the burner through  $90^{\circ}$  in all positions with reference to the horizontal and check whether any fuel escapes.

In the case of steam engines using solid fuel, fill the furnace in accordance with the manufacturer's instructions, tip the engine through  $90^{\circ}$  in all positions with reference to the horizontal.

Check whether any fuel escapes.

4.11.2 Boiler (see § 3.9.2 c))

Fill the steam engine with water and fuel in accordance with the manufacturer's instructions. Attach a manometer to the boiler opening.

Operate the steam engine until it starts running on no load and measure the corresponding steam pressure (service pressure).

Continue operating the engine with the steam outlets blocked until the safety valve operates. The pressure at the time the valve operates is measured (= release pressure). ./.



With the steam outlet and safety valve simultaneously blocked, operate the steam engine until the internal pressure of the boiler reaches a pressure corresponding to the higher of the following values:

- three times the service pressure
- twice the release pressure.

Then operate the steam engine under no load conditions until all the fuel is spent and measure the volume of water remaining in the boiler.

4.12 Projectiles (see § 3.10.1)

Determine the kinetic energy of the projectile five times and calculate the average value.

4.13 Facsimile protective equipment (see § 3.12)

Separate the transparent material from the toy and place it in the apparatus as shown in the figure, so that it is supported along its periphery. The support is made of rigid material adapted to the sample.

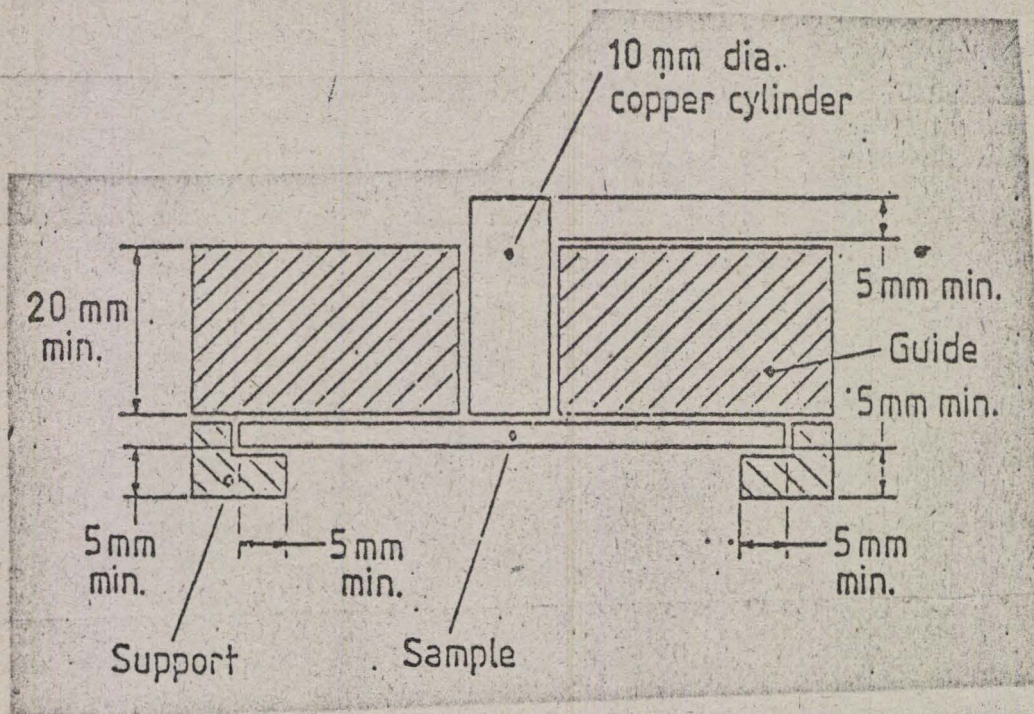

./.



The test is carried out at  $20 \pm 30^{\circ}\text{C}$ . Drop, in free fall, a mass of 1 kg from a height of 100 mm on to the top of the cylinder. Examine whether the material is cracked.

4.14 Filling materials for rattles (see § 3.13)

Measure the initial linear dimensions of the materials. Place them in water at a temperature of  $20 \pm 3^{\circ}\text{C}$  for 24 h.

Re-measure the dimensions.

4.15 Strength of rattles (see § 3.13 and 2.2.4)

Drop onto the rattle, placed on a horizontal steel surface, a metallic mass of 1 kg, distributed over an area of  $50\text{ cm}^2$ , from a height of 100 mm.

Examine whether the casing has broken.

4.16 Small toys and detachable elements (see § 3.1)

Place the toy (or the detachable elements) without pressing it in a cylinder of the dimensions indicated in the sketch (fig. 1).

If the toy fits in completely, in any position, it does not comply with the requirements of the standard.

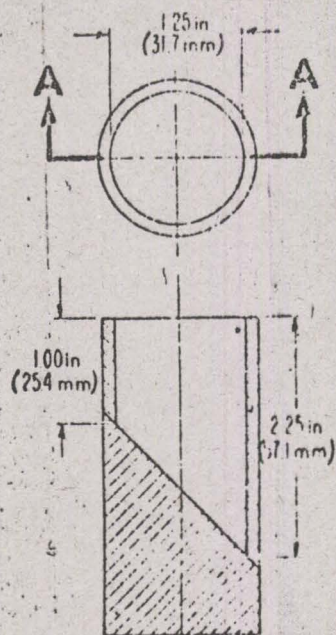

Fig. 1.



5. REQUIREMENTS AND METHODS OF TEST FOR TOYS' PACKAGING

Bags made of flexible plastics used for packaging, or necessary for the use of toys and with an opening perimeter greater than 380 mm, shall have a minimum thickness of 0.038 mm, and the means for closing the bag shall not be a drawstring or cord.

The thickness requirement is deemed to be met if the average plastics thickness, measured over an area of 100 mm x 100 mm, is not less than 0.038 mm.

This requirement does not apply to shrunk-on film packaging which is normally destroyed when the package is opened.



COMMON TECHNICAL STANDARDS AND METHODS OF TEST  
RELATING TO THE FLAMMABILITY OF TOYS

1. FIELD OF APPLICATION

This annex sets out:

- a) the general requirements relating to the flammability of toys and namely the categories of flammable materials which are forbidden for the manufacture of these products (§ 2);
- b) the specific requirements relating to the flammability of the following toys when they are submitted to a small source of ignition (§ 3).
  - Beards, moustaches, wigs and masks (§3.1)
  - Disguise costumes and elements of costumes (§3.2)
  - Toys intended to be entered by a child (§3.3)
  - Soft toys with pile fabrics (§3.4)
- c) the methods of test relating to the requirements described in a) and b) (§ 4).

2. GENERAL REQUIREMENTS

2.1 The following materials shall not be used in the manufacture of toys:

- Celluloid (cellulose nitrate) or materials with a similar behaviour in fire (except when used in varnish and paint): this interdiction does not apply to balls for table-tennis;
- Materials with a pile surface which produce a flash effect (1) on the approach of a flame, when tested in accordance with §4.3. This requirement does not apply to toys from which it is not possible, in view of their limited shape or dimensions, to obtain a specimen of at least 50 x 150 mm.

./.

---

(1) A rapid spread of flame over the surface of the article.



2.2 Furthermore, toys may not contain:

- a) flammable gases;
- b) substances or preparations as such which
  - may ignite when in contact with other substances (combustion-inducing substances and preparations) (1);
  - may become hot and spontaneously catch fire in contact with air, at an ambient temperature without any application of energy (2);
  - when in contact with water or damp air may evolve easily flammable gases in dangerous quantities (3).
- c) liquid or solid fuels or a part to be set alight, to be burnt or to give off smoke, unless these components are strictly essential to the function of the toy and provided that, in this case, the toy is manufactured in such a way as only to catch fire at the appointed spot and at no other.

3. SPECIFIC REQUIREMENTS APPLICABLE TO CERTAIN TYPES OF TOYS

3.1 Beards, moustaches, wigs and masks

Beards, moustaches, wigs and masks which are likely to be worn directly on the skin, when tested in accordance with § 4.2, shall not continue to flame, if ignition occurs, for more than 2 seconds after the source of ignition has been removed.

Toys which do not comply with this requirement must carry the warning provided for in Annex IV, 12: this provision cannot apply to masks which completely cover the head (e.g. hoods) or adhere to it strongly, which must always comply with the requirement set out in the first paragraphs.

./.

---

(1), (2), (3) See directive 67/548/EEC of 27 June 1967, art. 2 b) and art. 2 c), 1st and 4th dash. This article has been amended by art. 2.2. b), c) and d) of Directive 79/831/EEC of 18 September 1979 (O.J. L 259/10, 15.10.79)



### 3.2 Disguise costumes and elements of costumes

When disguise costumes or elements of costumes are tested in accordance with § 4.3, the rate of spread of the flames shall not be more than 50 mm/s (1).

Furthermore, if for such toys the rate of spread of the flame lies between 10 mm/s (2) and 50 mm/s, they shall bear the warning provided for in Annex IV. 12.

Costumes and elements of costumes made from thermosplastic materials (3) shall bear, whatever their rate of spread of the flame may be, the warning provided for in the previous paragraph.

Disguise costumes and elements of costumes made from PVC must be self-extinguishing.

### 3.3 Toys designed to be entered by a child

When toys designed to be entered by a child are tested in accordance with § 4.3 the rate of spread of the flame shall not be higher than 30 mm/s (4).

Furthermore, if for such toys the rate of spread of the flame lies between 10 mm/s (5) and 30 mm/s, they shall bear the warning provided for in Annex IV. 12.

./.

- 
- (1) i.e. the time taken for the flame to spread over the 500 mm test length shall not be less than 10 secs.
  - (2) i.e. the time taken for the flame to spread over the 500 mm test length shall not be less than 50 secs.
  - (3) Polyamide, polyester, certain modacrylics, etc.
  - (4) i.e. the time taken for the flame to spread over the 500 mm test length shall not be less than 17 secs.
  - (5) i.e. the time taken for the flame to spread over the 500 mm test length shall not be less than 50 secs.



Toys, made from PVC, designed to be entered by a child, shall be self-extinguishing.

Furthermore, the toys covered in the present paragraph shall allow easy exit, thus precluding the use of buttons, grips, etc.

3.4 Soft toys with a pile surface

When soft toys with a pile surface, or made of textiles are tested in accordance with § 4.4, the rate of spread of flame on the surface shall be not more than 50 mm/s.

The requirements of this paragraph do not apply to toys from which it is not possible, in view of their limited shape or dimensions, to obtain a specimen of at least 50 x 150 mm.

4. METHODS OF TEST

The following provisions apply to paragraphs 4.1 to 4.4:

- a) Each test is carried out on new articles as they are marketed or on samples obtained from new articles.
- b) The toys used for the tests shall be representative of one group of toys. Samples shall be taken so that they are representative of the whole toy.
- c) Before the flammability test,
  - toys made of textiles, with the exception of those which are not likely to be washed, such as toys made of paper, cardboard, etc., are subjected to the durability procedure provided for in § 4.5 or, if washing instructions were given by the manufacturer, they are washed 5 times in accordance with these instructions;

10	
9	
8	
7	
6	
5	
4	
3	
2	
1	

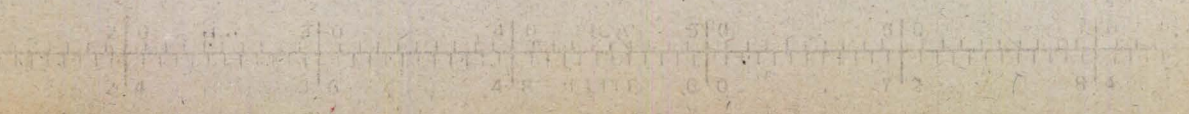



- the toys or samples shall be conditioned for at least seven hours in an atmosphere having a temperature of 20-25°C and a relative humidity of 50-65%.

- d) Wherever possible, the tests are carried out in a text cubicle for the purpose of safety of personnel and good test procedure (1).
- e) The test flame is obtained from a burner (2) operated with butane or propane gas and results from the mixture of the gas with the minimum of air to ensure its stability. The height of the flame is measured with the burner in the vertical position.

4.1 Test relating to the flash effect (see § 2.1, 2nd dash)

The test is carried out in accordance with Standard BS 4569. However, by way of derogation from this standard, the samples used for the test must be at least 50 x 150 mm.

4.2 Test relating to beards, moustaches, wigs and masks (see § 3.1)

Position the toy vertically or, if it contains pile elements or hair so that the element or hair hang vertically

Apply a 20 mm high test flame to the toy for 5 seconds so that the distance between the edge of the burner tube and the toy is approximately 5 mm with the burner at an angle of 45° and so that the flame makes contact at lease 20 mm above the lower edge of the toy.

Measure the period (in seconds) which elapses between the removal of the source of ignition and the time that the specimen ceases to flame.

---

(1) See for example the cubicles described in standards NF g 07-113 and DIN 50-050

(2) For indications consult for example standards NF G 07-100, DIN 50-051 and DB 5438



4.3 Test relating to disguise costumes and elements of costumes  
(see § 3.2) and to toys intended to be entered by a child  
(see § 3.3)

Obtain from the toy three samples with usable sizes of 600 mm x 80 mm. Each sample must consist of two cotton market threads 500 mm apart, the first marker being placed at least 50 mm from the lower part of the sample.

Place the sample on a U-type frame positioned at 45° to the horizontal.

With the burner in a vertical position, apply a 40 mm high test flame for 2 s to the lower part of the sample.

Measure the rate of spread of the flame between the two markets on each sample.

4.4 Test relating to soft toys with pile fabrics (see § 3.4)

Position the toy vertically. With the burner at an angle of 45°, apply a 20 mm high test flame to the surface of the article for 2 seconds, so that contact is made at least 20 mm above the lower ledge of the sample and that the distance between the edge of the burner and the surface of the test is approximately 5 mm.

After removal of the flame, measure the time taken for the flame to spread over the distance between the point of application of the flame and the upper edge of the toy.

4.5 Durability procedure

The procedure applied is the one provided for in British Standard BS 5651: 1978, in accordance with the following precisions:

- A) Disguise costumes and soft toys with a pile surface §§ 3.2 and 3.4):

./.



These toys are subjected to the domestic washing procedure provided for in chapter 6 (1) of the above-mentioned standard at a temperature of 50°C, unless they carry a label prescribing dry-cleaning: in this case, the procedure described in chapter 5 of the standard is to be applied.

In partial derogation of British Standard BS 5651, five complete cycles of washing or dry-cleaning are considered as sufficient.

B) Toys designed to be entered by a child (§ 3.3):

These toys are subjected to the water soaking procedure described in chapter 4 of the above-mentioned standard.

10  
9  
8  
7  
6  
5  
4  
3  
2  
1

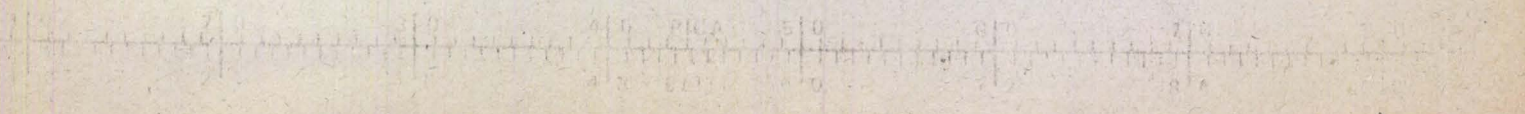



ANNEX VII

EEC SYMBOL OF CONFORMITY WITH THE COMMON TECHNICAL STANDARDS  
PROVIDED FOR IN ARTICLE 4.1

The EEC symbol of conformity consists in a capital epsilon 8 mm high, enclosed in an hexagon and accompanied by the following letters, at least 2 mm high, indicating the common technical standards according to which the toy has been tested and with which it was found to comply:

- M = physical and mechanical properties
- F = flammability
- T = toxicity
- E = electrical properties

Example of an EEC symbol of conformity for a toy which has passed the tests on physical and mechanical properties, flammability and electricity:





ANNEX VIII

CONDITIONS TO BE FULFILLED BY THE LABORATORIES  
(Article 18, paragraph 2)

The laboratories designated by the Member States must fulfill the following minimum conditions:

1. Availability of personnel as well as of the necessary means and equipment;
2. Technical competence of the personnel;
3. Independence, in carrying out the tests and preparing the technical reports provided for in this directive, of staff and technical personnel in relation to all circles, groups or persons directly or indirectly concerned with the field of toys;
4. Maintenance of professional secrecy by the personnel;
5. Submission to inspection at intervals by the competent authorities in the Member States.