

**KERNFORSCHUNGSZENTRUM
KARLSRUHE**

April 1977

KFK 2449

Laboratorium für Aerosolphysik und Filtertechnik

Iodine Filters in Nuclear Power Stations

J. G. Wilhelm

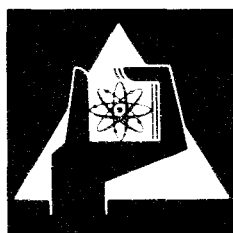

**GESELLSCHAFT
FÜR
KERNFORSCHUNG M.B.H.**

KARLSRUHE

Als Manuskript vervielfältigt

Für diesen Bericht behalten wir uns alle Rechte vor

**GESELLSCHAFT FÜR KERNFORSCHUNG M. B. H.
KARLSRUHE**

KERNFORSCHUNGSZENTRUM KARLSRUHE

KFK 2449 .

Laboratorium für Aerosolphysik und Filtertechnik

/ IODINE FILTERS IN NUCLEAR POWER
STATIONS */*

J.G. Wilhelm
"

Translated by Ralf Friese

= Report
prepared under Study Contract No. 075-74-5 PSTD,
Commission of the European Communities,
Directorate General for Social Affairs *=*

GESELLSCHAFT FÜR KERNFORSCHUNG MBH, KARLSRUHE
x

This document was reproduced as a manuscript.
All rights reserved for this document.

GESELLSCHAFT FÜR KERNFORSCHUNG MBH, KARLSRUHE

Foreword

In view of the special significance of radioactive iodine from the point of view of health protection, the Commission of the European Communities for many years has devoted particular attention to this component as contained in the effluents of nuclear facilities and to the problems arising from its elimination. A scientific symposium was held at Karlsruhe in December 1973 on the subject of "Iodine Filter Testing." As a consequence of the conclusions drawn from that symposium the Commission then launched a program of comparison of the techniques employed by different laboratories to measure the retention of iodine. It is hoped that the measuring techniques employed in this field can thus be harmonized and will lead to results which can be intercompared more meaningfully.

However, one of the major drawbacks felt by the symposium had been the absence of a complete description of the current state of the art in this special area of iodine filtration, a subject on which interest has become focused only after the advent of nuclear technology. In making available this publication the Commission intends to fill this gap and, in particular, make available a survey of aspects of particular interest to scientists and engineers engaged in practical work in nuclear power stations with new insights into the problems involved. It is hoped that this description of iodine filters and their problems in nuclear power stations, which has been written by an expert who himself has made important contributions to the development of filter technology in recent years, will find a positive reception and arouse new interest in this subject.

Dr. P. Recht

JODFILTER IN KERNKRAFTWERKEN

Zusammenfassung

Anhand errechneter und gemessener Abgaberraten von Kernkraftwerken wird die Bedeutung der Strahlenbelastung der Umgebung durch Spaltjod relativ zur Abgabe anderer Nuklide über den Luftpfad dargestellt. Die Freisetzungspfade für Spaltjod in leichtwassergekühlten Reaktoren und die Wirkung der verschiedenen Maßnahmen zur Reduktion der abgegebenen Aktivität werden angegeben. Beispiele für die Probenahme zur Fortluftüberwachung werden diskutiert und Hinweise für eine zweckmäßige Auslegung gegeben. Die einzelnen luftgetragenen Formen des Spaltjodes werden in Hinsicht auf die Abscheidung in Jod-Sorptionsfiltern und die Umgebungsbelastung diskutiert. Der Stand der Spaltjodabscheidung durch Jod-Sorptionsfilter wird für den bestimmungsgemäßen und den Störfall-Betrieb von Kernkraftwerken anhand der in der Literatur angegebenen Daten zur Abscheideleistung von verschiedenen Jod-Sorptionsmaterialien untersucht. Die Zweckmäßigkeit von Konzepten für Lüftung und Sicherheitseinschluß und ihre Auswirkung auf die Jodfilteranlagen wird diskutiert. Aufbau, Auslegung und Prüfung von Jod-Sorptionsfiltern werden im einzelnen behandelt; Empfehlungen zur Auslegung werden gegeben und Fehlerquellen angesprochen.

<u>TABLE OF CONTENTS</u>	<u>Page</u>
1. Iodine Release from Nuclear Power Stations	1
1.1. Relative Significance of Iodine Releases in the Environmental Impact of Nuclear Power Stations	1
1.2. Iodine Isotopes Important for Health Physics Considerations	7
1.3. Release Pathways	8
1.3.1. Release into the Reactor Coolant	8
1.3.2. Release Pathways in PWR Nuclear Power Stations	9
1.3.3. Release Pathways in BWR Nuclear Power Stations	11
1.4. Recorded and Licensed Discharges of ^{131}I with the Exhaust Air of Nuclear Power Stations	12
2. Airborne Radioiodine Species and their Significance in the Environmental Impact of Nuclear Power Stations	15
2.1. Iodine Compounds and Iodine Aerosols	15
2.2. Significance of Radioiodine Species with Respect to the Environmental Impact	17
3. Iodine Sorption Materials	22
3.1. Activated Carbon	22
3.1.1. Removal of Elemental Iodine by Activated Carbon	24
3.1.2. Removal of Methyl Iodide by Activated Carbon	24
3.1.3. Removal of Hypiodous Acid by Activated Carbon	26
3.1.4. Iodine Removal by Activated Carbon as a Function of Concentration	27
3.2. Status of Fission Product Iodine Removal by Activated Carbon under Normal Operating Conditions of Nuclear Power Stations	31

	<u>Page</u>
3.3. Status of Fission Product Iodine	32
Removal during Accidents	
3.3.1. Removal of Fission Product Iodine	33
by Activated Carbon at Elevated	
Temperatures	
3.3.2. Removal of Fission Product Iodine	35
by Activated Carbon under the	
Influence of High Radiation Dose	
Rates	
3.3.3. Inorganic Sorption Materials for	36
Iodine Removal at High Temperature	
and High Dose Rates	
3.3.4. Removal of Fission Product Iodine at	39
High Humidity of the Air and from	
Saturated and Superheated Steam	
4. Requirements to Be Fulfilled by Iodine Filter	44
Systems in Nuclear Power Stations	
4.1. Ventilation Concepts and Filters for Normal	44
Operation of a Nuclear Power Plant	
4.2. Containment Concept and Requirements to Be	47
Fulfilled by Standby Emergency Filter	
Systems for Cleanup of the Exhaust Air from	
the Annulus	
4.3. Requirements to Be Fulfilled by Iodine	51
Filter Systems in Normal and Post-Accident	
Operation of Nuclear Power Stations	
5. Design of Iodine Filter Systems	57
5.1. Individual Elements and Their Arrangements	57
5.2. Redundancy Requirements	59
5.3. Design and Structure of Iodine Sorption	60
Filters	
6. Surveillance of Iodine Filter Systems	72
6.1. Testing the Iodine Sorption Material	72
6.1.1. Scope of Test	72
6.1.2. Test Agents and Equipment	73
6.1.3. Establishing the Test Conditions	75
of Iodine Sorption Materials	

	<u>Page</u>
6.1.4. Measurement of other Properties of Activated Carbon	81
6.1.5. Removing Representative Activated Carbon Samples from Iodine Sorption Filters	82
6.2. In-Place Testing of Iodine Sorption Filters	83
6.2.1. Objectives	83
6.2.2. Test Agent	84
6.2.3. In-Place Testing of Iodine Sorption Filters with Radioactively Labeled Methyl Iodide	88
6.2.4. In-Place Testing of Iodine Sorption Filters with Freons	89
6.2.5. Validity of In-Place Tests of Iodine Sorption Filters with Respect to the Removal Efficiency under Emergency Conditions	92
7. Experience in Operating Iodine Filter Systems	93
7.1. The Occurrence of Mechanical Leaks	94
7.2. Poisoning of the Iodine Sorption Material	94
7.3. Fires in Iodine Sorption Filters	100
8. Conclusions and Recommendations	100
Illustrations	103- 110
Literature	111 - 118
Abstract	VIII

APPENDIX

I. Methods of Preparing Radioactively Labeled Methyl Iodide and Elemental Iodine	1
II. Test Apparatus for Measuring the Removal Efficiencies of Iodine Sorption Materials	4
III. Evaluation of the Removal Efficiency Tests of Iodine Sorption Materials	12
IV. In-Place Test of Iodine Sorption Filters with Radioactively Labeled Methyl Iodide	14
IV. 1. Transport of the Radioactive Test Agent	14
IV. 2. Test Setup and Test Performance	16
IV. 3. Calculating the Required Radioactivity of the Test Agent and the Penetration of the Iodine Sorption Filter	18
IV. 4. Safety Assessment, Preliminary Test	20

<u>List of Tables</u>		<u>Page</u>
Table I:	Calculated maximum dose equivalent rates at the site boundary of a nuclear power station due to the discharge of noble gases from 1000 MWe nuclear power stations.	2
Table II:	Calculated maximum dose equivalents at the site boundary of a nuclear power station due to the discharge of radioiodine from 1000 MWe nuclear power stations.	3
Table III:	Total stack release of long lived aerosol and gaseous radionuclides of a 660 MWe PWR nuclear power station in 1973.	6
Table IV:	Radiation exposure by a 660 MWe PWR nuclear power station at the point of maximum impact (data calculated on the basis of the measured stack release).	7
Table V:	Stack releases of gaseous ^{131}I of nuclear power stations.	13
Table VI:	Sampling stations to monitor stack release.	14
Table VII:	Iodine species released by different boiling water reactors.	20
Table VIII:	Removal efficiencies for ^{131}I as $\text{CH}_3^{131}\text{I}$ at high and intermediate radioactivity concentrations in the influent air.	30
Table IX:	Removal efficiencies of Norit RX-08-C activated carbon (immersion impregnated with 1% KI) for ^{131}I (as $\text{CH}_3^{131}\text{I}$) at different relative humidities of the air.	39, 40
Table X:	Typical accident conditions for atmosphere cleanup systems (from: USAEC Regulatory Guide 1.52).	53

VI

	<u>Page</u>
Table XI: Typical operating conditions and requirements to be met by iodine filters under normal operating conditions and accident conditions.	54
Table XII: Preliminary test conditions in the Euratom intercomparison tests of the removal efficiencies of activated carbon.	79
Table XIII: Laboratory test requirements for activated carbon for fission product iodine removal.	80
Table XIV: Summary of the physical properties to be measured on new activated carbon for fission product iodine removal.	81
Table XV: Removal efficiencies of iodine sorption filters initially and after the first six months of filter operation in a newly built power station.	96

VII

<u>List of Illustrations</u>	<u>Page</u>
Fig. 1: Ventilation concept of a modern pressurized water reactor.	103
Fig. 2: "Gasketless" deep bed iodine sorption filter of the vessel type with horizontal gas flow.	104
Fig. 3: Penetration of non-impregnated activated carbon by ^{131}I in the form of elemental iodine and methyl iodide.	105
Fig. 4: Penetration of activated carbon beds by ^{131}I (loaded as CH_3I) under various humidity conditions of activated carbon and air.	106
Fig. 5: Ventilation system of a modern German pressurized water reactor.	107
Fig. 6: Pleated-bed filter cell with activated carbon.	108
Fig. 7: Cartridge type filter cell with activated carbon.	109
Fig. 8: Filter wall with aerosol and iodine sorption filters.	110
 <u>APPENDIX</u>	
Fig. 9: Apparatus for the preparation of methyl iodide.	1
Fig. 10: Apparatus for the preparation of elemental iodine.	2
Fig. 11: Laboratory scale apparatus for testing iodine sorption material.	4
Fig. 12: Water vapor adsorption onto impregnated activated charcoal.	9
Fig. 13: Apparatus for testing iodine sorption material in steam-air mixtures under pressure and high temperature.	11
Fig. 14: Transport and feed systems for radioactive test agent.	14
Fig. 15: Iodine sampler.	17
Fig. 16: Setup for in-place test of an iodine sorption filter.	18

Abstract

On the basis of calculated and measured release rates of nuclear power stations the significance of the dose equivalent rate from fission product iodine is assessed in relation to that of other nuclides discharged through airborne pathways. The release pathways for fission product iodine in light water cooled reactors and the effectiveness of various measures taken to reduce the radioactivity released are indicated. Examples of sampling for exhaust air monitoring are discussed and references are made to optimum designs. The different airborne species of fission product iodine are discussed with respect to the removal in iodine sorption filters and the environmental impact. The status of fission product iodine removal by iodine sorption filters is investigated for operation under normal and emergency conditions of nuclear power stations on the basis of data mentioned in the literature on the removal efficiency of different iodine sorption materials. The usefulness of ventilation and containment concepts and their repercussions on iodine filter systems are discussed. The design, structure and testing of iodine sorption filters is treated in detail. Recommendations are given with respect to design, and sources of error are indicated.

1. Iodine Release from Nuclear Power Stations

1.1. Relative Significance of Iodine Releases in the Environmental Impact of Nuclear Power Stations

A comparison of the radiation exposure to be expected as a result of the emission of various radionuclides into the environment of nuclear power stations shows that the decisive radionuclide with respect to environmental impact is ^{131}I . This statement is largely correct, irrespective of the fact that the containment and ventilation systems concepts are characterized by major variations in different reactor plants and that the absolute and relative levels of discharges actually encountered in practice are influenced to a large degree by the concepts selected. Since most of the nuclear power stations presently in operation or under design are equipped with pressurized water reactors or boiling water reactors, the data referred to for comparison in Tables I and II are limited to these two designs. For the airborne exposure pathway only radioactive isotopes of the noble gases xenon and krypton and those of iodine are significant and, for this reason, are the only ones mentioned. The radiation exposure due to the discharge of radioactive aerosols is insignificant by comparison. The source from which the data compiled in Tables I and II were taken is a report by the U.S. Environmental Protection Agency /1/ which, among other data, was compiled on the basis of information distilled from a number of safety reports of recent American nuclear power stations. An annual average atmospheric dispersion factor of $\bar{\chi}/Q = 3.3 \times 10^{-7} \text{ s/m}^3$ for a river site, a stack height of 100 m and a local impact point at 0.8 km distance (site boundary of the nuclear power station) are probably representative also of a number of European nuclear power stations. +)

+) Note: The large number of additional parameters that have formed part of the basis of calculation of the dose equivalent rates in Table II cannot be repeated here. For further details, see /1/.

Table I: Calculated maximum dose equivalent rates at the site boundary of a nuclear power station due to the discharge of noble gases from 1000 MWe nuclear power stations

Pressurized water reactor			Boiling water reactor		
Systems reducing the radioactivity discharged	Source term /Ci/yr/	Whole body dose equivalent rate ^{a)} /mrem/yr/	Systems reducing the radioactivity released	Source term /Ci/yr/	Whole body dose equivalent rate ^{a)} /mrem/yr/
None	1.7 (5)	3.1	Delay line, 30 min, 100 m height, of stack ^{b)}	2.6 (6)	162
Activated carbon adsorption beds, 15 d Xe	2.6 (4)	0.33	Delayed release, 24 h, 100 m height of stack ^{b)}	3.0 (5)	3.9
Activated carbon adsorption beds, 45 d Xe	4.0 (3)	0.05	Activated carbon adsorption beds, 20 d Xe	4.3 (4)	2.4
Additional cover gas recycle	4.7 (2)	0.02	Activated carbon adsorption beds, 40 d Xe	2.7 (4)	2.2

a) Maximum individual dose rates at the impact point at a distance of 0.8 km.

b) \bar{X}/Q at 100 m stack height $3.3 \times 10^{-7} \text{ m}^3/\text{s}$, for vent release at 10 m height, $2.9 \times 10^{-6} \text{ m}^3/\text{s}$.

Note: 1.7 (5) = 1.7×10^5 , etc.

Table II: Calculated maximum dose equivalents at the site boundary of a nuclear power station due to the discharge of radioiodine from 1000 MWe nuclear power stations (assumption: all iodine is present in its elemental form)

Pressurized water reactor				Boiling water reactor			
Systems reducing the radioactivity discharged	¹³¹ I source term /Ci/yr/	¹³³ I source term /Ci/yr/	Thyroid dose rate due to radioiodine ^{c)} /mrem/yr/	Systems reducing the radioactivity discharged	¹³¹ I source term /Ci/yr/	¹³³ I source term /Ci/yr/	Thyroid dose rate due to radioiodine ^{c)} /mrem/yr/
None (except for gaseous waste treatment system) ^{d)}	0.76	0.31	284	Delay line, 30 min, 100 m stack height	15	88	685
Recirculation activated carbon filters in containment	0.52	0.28	197	Activated carbon adsorption beds for condenser air ejector	0.50	2.9	206
Steam generator blowdown vented to main condenser	0.24	0.11	91	Clean steam for all valves > 2.5" dia.	0.11	0.64	45
Auxiliary building and containment purge through shallow bed activated carbon filters (DF 10)	0.088	0.05	33	Turbine building exhaust air through shallow bed iodine filters (DF 10)	0.022	0.13	9
Steam jet air ejector activated carbon adsorber	0.043	0.022	16	Turbine building exhaust air through deep bed activated carbon filters (DF 100)	0.013	0.074	5.3

Continued on page 4

Table II, continued

Pressurized water reactor				Boiling water reactor			
Systems reducing the radioactivity discharged	¹³¹ I source term /Ci/yr/	¹³³ I source term /Ci/yr/	Thyroid dose rate due to radioiodine ^{c)} /mrem/yr/	Systems reducing the radioactivity discharged	¹³¹ I source term /Ci/yr/	¹³³ I source term /Ci/yr/	Thyroid dose rate due to radioiodine ^{c)} /mrem/yr/
Auxiliary building and containment purge through deep bed activated carbon filters (DF 100)	0.027	0.016	10	Radwaste building and reactor building vented through shallow bed activated carbon filters (DF 10)	0.005	0.028	2.0
Clean steam for all valves > 2.5" dia.	0.011	0.0065	4.2	Turbine gland seal with clean steam	0.002	0.011	0.8
Turbine gland seal with clean steam	0.0105	0.006	4.0				

c) Maximum individual thyroid dose equivalent rate.

All exposure pathways are taken into account, the uptake being calculated for the "average individual."

Milk is supplied by cows grazing in the environment of a nuclear power station uniformly distributed up to a maximum of 80 km distance.

d) Assumption: radioiodine from primary system gases (shutdown degasification, shim bleed) is effectively removed by gaseous waste treatment system.

The data in Table II indicate relatively high thyroid dose rates in the absence of special retention systems. For instance, in the United States, under Appendix I of 10 CFR Part 50, a dose limit of 15 mrem/a at the boundary of the nuclear power station site is the valid level. Under the assumptions underlying Table II this level can be reached in a PWR nuclear power station by the installation of iodine filter systems for internal recirculation air treatment in the containment and exhaust air treatment for the containment and the auxiliary systems building, plus the additional measures indicated. In BWR nuclear power stations, according to the data from Table II, even the exhaust air from the turbine building would have to be released through iodine filters (or a stack of sufficient height).

By comparison, the effort necessary to reduce the release of noble gases is small. In BWR nuclear power stations the mere installation of an activated carbon adsorption bed with a retention time of 20 d for Xe is sufficient to clean up the exhaust gas of the condenser air ejector and fall below the permissible limit of 5 mrem/a for the whole body dose equivalent rate. Frequently, a retention time of ≥ 40 d(Xe) is chosen. In PWR nuclear power stations, this dose limit according to Table I is underrun even without additional measures being taken.

The activity discharges in aerosols, iodine and noble gases actually measured by means of β -spectrometry in the stack release of a modern PWR nuclear power station (660 MWe) are shown in Table III.

The ventilation concept of this nuclear power station is outlined in Fig. 1.

A comparable measurement of the radioiodine in the different exhaust air lines and sections of rooms under normal reactor operating conditions for one week showed the maximum amount of ^{131}I in the exhaust air of the equipment compartment, as was to be expected. The decontamination factor of the iodine filter treating the exhaust air from the equipment compartments, a 50 cm deep activated carbon bed with a residence time of 2 s, in this period of measurement indicated a DF = 85,700 relative to the mixture of iodine species occurring in the exhaust air /3/.

Table III: Total stack release of long lived aerosol and gaseous radionuclides of a 660 MWe PWR nuclear power station in 1973 /2/

Nuclide	Release in mCi				
	1st quarter	2nd quarter	3rd quarter	4th quarter	1973 total
Mn- 54		0.018	0.907	0.038	0.963
Co- 58	0.007	0.057	3.74	0.248	4.052
Co- 60	0.001	0.035	1.10	0.086	1.222
Nb- 95			0.230	0.005	0.235
Zn- 95			0.064		0.064
Ru-103			0.171		0.171
Ru-106	0.021				0.021
Ag-110 m			0.124	0.011	0.135
I-131 aerosol				0.04	0.04
I-131 gaseous	13.9	26.3	2.51 +)	6.75	49.46
Cs-134	0.002	0.075	0.164	0.002	0.243
Cs-137	0.006	0.267	0.423	0.015	0.711
Ce-141			0.054		0.054
Ce-144			0.048		0.048
Sb-124			0.236	0.013	0.249
Total release, noble gas radioactivity:			2600 Ci (delayed release through delay tanks)		
Total release of aerosol radioactivity excluding ^{131}I			: 8.2 mCi		
Total release of aerosol radioactivity, ^{131}I only			: 0.04 mCi		
Total release of gaseous iodine radioactivity, ^{131}I			: 49.46 mCi		

+) No measurement in the 4 weeks of refueling.

Table III shows that the long lived aerosol radioactivity released with the exhaust air reached approximately 1/6 of the gaseous ^{131}I radioactivity. From the data shown in Table III no conclusion can be drawn as to the distribution of ^{131}I in gaseous and particulate species because, by the end of the collection time, part of the iodine originally collected on the aerosol filter has probably been desorbed and removed in the activated carbon filter downstream.

For the environmental burden at the most adverse point of impact the levels shown in Table IV were calculated:

Table IV: Radiation exposure by a 660 MWe PWR nuclear power station at the point of maximum impact (data calculated on the basis of the measured stack release)

Type of radiation exposure	mrem/a
Whole body dose equivalent rate due to γ -radiation from radioactive noble gases	0.05
Skin dose equivalent rate due to β -radiation from radioactive noble gases	0.01
Thyroid dose equivalent rate of infants	0.5
Whole body dose equivalent rate due to radioactive aerosols	1.4×10^{-3}

Additional data on iodine discharge with the stack release can be found in Table V.

1.2. Iodine Isotopes Important for Health Physics Considerations

^{131}I ($T_{1/2}$: 8.04 d) is the most important iodine isotope safetywise and determining the radiation exposure of the plant crews and the environment during normal operation and accidents in nuclear power stations.

^{133}I ($T_{1/2}$: 21 h) must also be specially taken into account in calculating the radiation exposure; only the uptake by inhalation is of practical importance.

^{132}I ($T_{1/2}$: 2.4 h), ^{134}I ($T_{1/2}$: 52 min) and ^{135}I ($T_{1/2}$: 6.6 h) are of minor relevance because of their relatively short halflives. In calculating the load of iodine filters due to the decay heat of the fission product iodine removed, also the contribution made by these radioisotopes must be taken into account in the case of reactor accidents which give rise to a spontaneous release of major fractions of the fission product iodine inventory from the fuel.

^{129}I ($T_{1/2}$: 1.6×10^7 a) and ^{127}I (non-radioactive) make up most of the mass of fission product iodine in the fuel elements of a reactor which has been operated over long periods of time. The bulk of these iodine isotopes must be taken into account in calculating the amount of iodine sorption material needed. ^{129}I is of importance for radiation protection purposes only in reprocessing plants and their environments.

1.3. Release Pathways

1.3.1. Release into the Reactor Coolant

The core of a 1000 MWe reactor, after reaching its radioactive equilibrium, contains approximately 7.5×10^7 Ci of ^{131}I and 1.7×10^8 Ci of ^{133}I . Part of the fission product iodine inventory gets into the primary coolant due to defects in the fuel element claddings.

The coolant is expected to contain up to 1% of the iodine inventory in the gap between the pellets and the fuel cladding. In normal operation, coolant activities due to radioiodine reach maximum levels of a few Ci/m^3 .

The specific ^{131}I activity of the primary coolant of the pressurized water reactor whose quarterly data are indicated in Table III, in the period under review and in normal operation under full load conditions, turned out to be 0.1 Ci to 0.2 Ci of $^{131}\text{I}/\text{m}^3$.

Primary coolant purification greatly influences the iodine fraction in the coolant because the decontamination factors of the ion exchangers may be very high.

Accordingly, increasing the bypass flow of primary coolant through the coolant purification system is an effective way of reducing the activity at a given release rate of the reactor core.

1.3.2. Release Pathways in PWR Nuclear Power Stations

Three release pathways must be distinguished. Radionuclides will be discharged with

- (1) the offgas of the primary circuit,
- (2) the offgas of the secondary circuit,
- (3) the exhaust air of the building ventilation.

Offgas of the Primary Coolant System

The offgas of the primary coolant system is fed to an offgas treatment system. The offgas system of the primary coolant system may be connected to the gas spaces of the volume control surge tank, the scrubber, coolant storage system, boric acid storage tank, pressurizer relief tank and the liquid effluent evaporator and drain tank. To reduce the activity discharged into the exhaust air from the offgas system, decay tanks have been installed or the release is made through activated carbon beds.

Offgas of the Secondary Coolant System

Primary coolant together with the radioactivity contained in it may get into the secondary coolant through leakages of the steam generators. Iodine together with the gases removed from the turbine condenser may be released. Moreover, part of the steam generator bottom liquid is continuously withdrawn to remove the solids precipitated during evaporation. The coolant withdrawn is relieved into a flash tank, part of the radioactivity of iodine may be released with the offgas of the flash tank, the other fraction remains in the residual water and passes into the liquid waste treatment system.

When the safety valves of the secondary circuit are actuated, and in case of a blowdown of the secondary circuit due to an incident (connected with the failure of the turbine condenser to act as a heat sink), considerable environmental exposure may result, especially if the steam is released above the roof of the turbine building.

Exhaust Air

Primary circuit leakages, above all, give rise to contamination of the room air in the equipment compartments ⁺⁾ Internal recirculating air filters and exhaust air filters are capable of drastically reducing the levels of airborne radioactivity. In addition, a major fraction of the iodine released is found together with the condensate in the recirculation air coolers of the equipment compartments. Depending on the ratio of volumetric flow rates through recirculation air coolers and recirculation air filters and the amount of water condensed, this fraction may by far exceed the iodine radioactivity removed by internal recirculating air filters. The storage pool for used fuel elements may give rise to contamination of the air in the operating compartments. Moreover, the air of the annular rooms and of rooms of the auxiliary systems building may become contaminated.

The anticipated reduction in the discharge of iodine brought about by systems installed to reduce the radioactivity released by a PWR nuclear power station can be taken from Table II.

In the surveillance period of the exhaust air radioactivity of a PWR nuclear power station on which the data in Table III are based, the iodine radioactivity released per unit time in various sections of the containment was measured over a period of one week under normal operating conditions at full load.

The ratio of the radioactivity released from equipment compartments, operating compartments, annular rooms and auxiliary systems building turned out to be 1 : 0.2 : 0.05 : 0.09. The iodine filter reduced the radioiodine released

⁺⁾ also denoted "plant compartments".

with the exhaust air from the equipment compartment by a DF of 85,700 and, hence, made it the smallest source of stack release. Of course, figures like those quoted in this paper are very much dependent on design and structural details as well as the ventilation concept and, for this reason, cannot easily be extrapolated.

1.3.3. Release Pathways in BWR Nuclear Power Stations

Two release pathways must be taken into account:

- (1) through the steam circuit,
- (2) through the exhaust air.

Steam Circuit

In boiling water reactors the contaminated steam is directly passed to the turbine; approximately 1 % of the radioiodine of the evaporated cooling water passes into the steam. This value is largely dependent on the degree of water-steam separation achieved in the steam drier. Gaseous radioactivity is continuously withdrawn with the condenser air ejector and, in more recent boiling water reactor designs, released through activated carbon adsorption beds. These practically act as iodine filters with extremely high removal efficiency, which allows the residual amount of radioiodine passing through the carbon beds to be neglected.

Exhaust Air

Leakages in the steam circuit allow radioactivity to enter the atmosphere of the containment and the reactor building, respectively, and to be discharged via the stack together with the exhaust air through filters or unfiltered.

The amount of radioactivity released depends on a multitude of factors, such as the level of coolant contamination, the design of valves in the steam circuit, the availability of systems to reduce the release, the mode of operation of the ventilation systems (fresh air, recirculation air modes), and the number of purges and the filter concept, respectively.

Further coolant leakages must be expected in the turbine building and the auxiliary systems building. A turbine gland seal exhaust system and a valve seal leak-off system equipped with condenser and filters can greatly reduce the discharge radioactivity. In most cases, the turbine gland

seals are bled with non-radioactive process steam which is removed via a gland seal steam condenser. The gaseous radio-nuclides are discharged through a delay line via the roof of the turbine building or the stack.

1.4. Recorded and Licensed Discharges of ^{131}I with the Exhaust Air of Nuclear Power Stations

For purposes of comparison, Table V lists measured results from the monitoring of stack release. The data refer exclusively to nuclear power stations which have been in operation for a number of years.

The iodine discharges of a few German reactors were compared with the discharge rates referred to in the licenses. The radioiodine in these nuclear power stations was sampled from a partial stream of the exhaust air passed to the stack and was collected on activated carbon filters (iodine samplers). The iodine retained in the iodine samplers over a period of seven days was measured by γ -spectrometry.

The iodine fraction in the stack release retained on an aerosol filter upstream of the activated carbon filter was less than 3% of the gaseous iodine.

Some of the data in Table V were taken from /2/, others were calculated from data listed in /4/.

The release levels of boiling water reactors show major differences which are probably due, above all, to the different treatment of the condenser air ejector offgas.

This offgas is passed through activated carbon beds only in the nuclear power station listed under No. 3 and in this way practically all iodine is removed. The low release levels of pressurized water reactors are probably due largely to the continuous filtration of iodine and aerosols in the exhaust air from the equipment compartments.

The licensed discharge levels have been greatly reduced over the years; in the pressurized water reactor listed under No. 5 the ratio of the licensed release rate to the measured one is only 24 : 5.6.

Table V: Stack releases of gaseous ^{131}I from nuclear power stations

Cons. No.	Type	Power MWe	Commissioning date	Continuous iodine filtration	Activated carbon bed adsorption	^{131}I release rates				Licensed release rate $\mu\text{Ci/h}$
						1972		1973		
						$\mu\text{Ci/h}$	mCi/yr	$\mu\text{Ci/h}$	mCi/yr	
1	BWR	645	1969	no	no	-	-	23-1800 ⁺⁾	-	-
2	BWR	572	1971	no	no	-	-	160-1080 ⁺⁾	-	-
3	BWR	252	1966	no	yes	22	195	218	1910	2500
4	PWR	345	1969	yes	no	0.7	6	0.57	5	1700 ⁺⁺⁾
5	PWR	660	1972	yes	no	4.9	43	5.6	49	24

⁺⁾ Minimum and maximum levels measured over a period of approximately 2 months.

⁺⁺⁾ 14 $\mu\text{Ci/h}$ in the grazing period.

A factor which remains doubtful is the type of sampling conducted to measure the activity of the ^{131}I contained in the exhaust air. More accurate data were available only for sampling points in the nuclear power stations listed in Table V under No. 3 to 5 and are shown in Table VI. The list shows variations which are likely to have a profound influence on the measured result.

Table VI: Sampling stations to monitor stack release

Sampling tube			Iodine sampler			
Nuclear power station, cons. No.	Length	Dia-	Material	Bulk volume of activated carbon	Vol-umetric flow rate of air	Residence time
	[m]	[cm]				
3	55	2	C-steel	59.4	1940	0.031
4	10	2.5	VA-type steel	189	417	0.45
5	1.6	2	Teflon	320	417	0.75

Some of the iodine samplers are connected to the stack by very long sampling tubes whose adsorption and plate-out efficiency (tube factor) is either unknown or not known accurately enough. Both effects in the sampling tubes have not been taken into account in the data indicated. In one case, the amount of activated carbon used for sampling is much too small to ensure even approximately complete iodine removal and there is no information about the removal efficiency of the activated carbon used.

A more reliable measurement of radioactivity will be possible only as a result of a more standardized design of the sampling stations, which includes the use of a sufficient amount of activated carbon of a known high removal efficiency, also relative to organic iodine compounds. A design is suggested which gives rise to an overall residence time of 0.4 s. To check the completeness of removal, the activated carbon should be subdivided into two consecutive beds which can be measured separately /5/.

There is a marked dependence of the tube factor on the iodine species and, hence, on the composition of the iodine mixture in the exhaust air, and also on changes in the sorption properties of the tube surfaces, for instance, due to oxidation and deposition (dust, oil). Therefore, the tubes should be as short as possible and should be made of a material with low adsorption capability, such as teflon. If the tubes are longer, the tube factor should be controlled from time to time by measuring the specific iodine radioactivity of the exhaust air right at the point of intake and comparing it with the radioactivity removed by the iodine sampler after passage through the tube. This is necessary in particular in the first year of operation in which it is not likely that an adsorption-desorption equilibrium is reached on the tube surface.

Measured data indicating the true environmental impact exist only for the first two of the nuclear power stations listed in Table V, because only in these cases so much radioiodine had been released with the exhaust air that the limits of detection of the measuring techniques had been exceeded.

The results of measurements of the local radioiodine concentrations [47] can be summarized as follows: The airborne radioiodine concentration in the environment of the nuclear power station listed as No. 1 in Table V was much higher than had been calculated in the diffusion model of the USAEC [67]. For the nuclear power station listed as No. 2, lower levels were found than those calculated. However, when additional measurements made at different sites are taken into account, the conclusion may be drawn that the predictions by the diffusion model are not too conservative but may rather lead to calculated values which are on the low side.

2. Airborne Radioiodine Species and their Significance in the Environmental Impact of Nuclear Power Stations

2.1. Iodine Compounds and Iodine Aerosols

Since iodine is a chemically very reactive element, the formation of iodine compounds must be assumed when iodine is released in its elemental form and finds suitable reaction

partners. Thus, the reaction between iodine and the methane always present in the air in small quantities gives rise to methyl iodide $\angle 77$. A particularly effective reaction must be expected if there is a large excess of methane over iodine and if organic compounds are split up in radicals in strong radiation fields $\angle 87$.

Usually the fraction of airborne organic compounds is on the order of a few mg/m^3 and may rise by several orders of magnitude in the room air of nuclear facilities as a result of vapors of lubricants and solvents. In the exhaust air filters of the plant compartments of one nuclear power station solvent contents of more than 11 % of the weight of activated carbon were found, which indicated a very high fraction ($\gg 10 \text{ mg}/\text{m}^3$) of solvent vapors $\angle 97$. In addition to the reaction between elemental iodine and organic compounds occurring as vapors in the gas phase, the iodine, following adsorption onto surfaces, may react with the organic substances existing there practically all the time, e.g., oil and grease films, paint coats, and the iodine compounds formed may be desorbed again $\angle 107$.

The simplest organic iodine compound is methyl iodide (CH_3I), to which reference has been made above. It was identified as early as in 1963 as a reaction product in the room air following the release of elemental iodine and subsequently has been detected in the room and exhaust air and the offgases of reactors $\angle 11, 127$. Also higher alkyl iodides have been detected.

Since iodine undergoes hydrolysis in aqueous solutions, reacting to hypiodous acid according to the formula

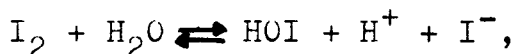

and since hypiodous acid dissociates only to a very small extent and, according to most recent studies, can occur also in the vapor phase, it is quite possible that the generation of elemental iodine in aqueous solutions gives rise to the release of gaseous hypiodous acid from the solution. Although direct proof of the existence of hypiodous acid as a vaporous component has not yet been produced,

there are several reactions which seem to indicate that this component is present in the offgas and the exhaust air [13, 14, 15].

Another inorganic gaseous iodine compound is hydrogen iodide (HI), which in practice must be expected to occur only under reducing conditions. Fission product iodine may also occur in a particulate form. The particles may consist either of iodine compounds with very low vapor pressures (e.g., metal iodides) or of other materials which have adsorbed iodine. Also droplet aerosols may contain iodine or absorb it, which process may contribute significantly to the transport of airborne radioiodine onto the surface of the earth [4].

Given the extremely low mass concentrations of fission product iodine in the room air and the exhaust air of nuclear power stations ($\ll \mu\text{g}/\text{m}^3$ in normal operation) and the relatively high partial vapor pressures, fission product iodine both in its elemental form and as methyl iodide occurs practically only as a vapor. This is probably true also of a number of higher alkyl iodides.

By far not all the radioiodine compounds existing as vapors in the room air and the exhaust air of nuclear power stations have already been identified. In a number of measurements gaseous iodine compounds have been found which are difficult to separate and whose chemical nature is still unknown.

Because of the high reactivity of iodine, especially in the presence of radiation induced radicals, a broad spectrum of iodine compounds must be expected which, however, will probably include only a very small fraction of the total amount of iodine released [16].

2.2. Significance of Radioiodine Species with Respect to the Environmental Impact

The question that arises first and foremost in this context is that of the necessity for further identification of the species of fission product iodine occurring in the room air and the exhaust air of nuclear power stations. Since they determine the transport, filtering and plate-out properties,

a more detailed identification would in principle be welcome. However, with the high decontamination factors that can practically be achieved with deep bed filters used on fission product iodine mixtures under normal operating conditions, this appears to be necessary only for more realistic assumptions in the licensing procedure on the adsorption and plate-out behavior of fission product iodine species on pasture and crop plants. The reason is that the iodine uptake by ingestion, because of enrichment through the pasture-cow-milk pathway, can by far exceed the uptake through inhalation and must be taken into account accordingly in calculating the environmental impact.

The permissible ^{131}I emission of a specific nuclear power station is 14 $\mu\text{Ci/h}$, for instance, during the grazing period while, for the rest of the year, 1700 $\mu\text{Ci/h}$ is the limit (see Table V, No. 4). By taking into account the milk pathway, the permissible iodine emission was reduced by a factor of 121.

Such restrictions are based on the assumption usually made in the licensing procedure that all the iodine released is present in its elemental form and for this reason is deposited on green plants with a comparatively high deposition velocity. When taking into account the pasture-cow-milk pathway, the iodine emission may therefore well become the limiting factor in the construction of several nuclear power units on one site or in one area, even if the nuclear power stations are assumed to be equipped with large numbers of iodine filters with high removal efficiencies.

The application levels for new nuclear power stations in the Federal Republic of Germany, as far as the release of ^{131}I is concerned, are in the range between 0.2 and 1 Ci of $^{131}\text{I/a}$. Thyroid dose rates for infants have been calculated to be up to 90 mrem/a $\angle 177$ for reactor sites in the Upper Rhine valley, for existing and planned reactor sites, taking into account potential overlapping of different sources of emission and under the assumption that all plants planned in this region are in operation. These are levels which would

practically make it impossible to build more nuclear generating units on one common site or in an entire region.

Unfortunately, no sufficient documentation is as yet available about the composition of fission product iodine mixtures at the point of emission, and there is practically no information at all about the composition at the point of impact. Some data may be taken from a study referred to above, which was published in 1975 by the U.S. Nuclear Regulatory Commission [47]. For the nuclear power stations listed under No. 1 and 2 in Table V, selective iodine species samplers were used to produce data about the composition of the iodine mixture released into the environment with the exhaust air and exhaust gas. The iodine samplers consisted of several aerosol filters, one layer of chromosorb-P impregnated with cadmium iodide for the removal of elemental iodine, one layer of aluminum oxide impregnated with 4-iodophenol for the removal of HOI, the silver form of the Linde 13 X type molecular sieve for the removal of methyl iodide, and impregnated activated carbon for the removal of other highly volatile components. However, the paucity of data in the literature gives rise to the assumption that the components of the iodine mixture are removed but unsatisfactorily in the different stages of the samplers [157].

The fractions quoted for organic iodine in Table VII, with one exception, are between 35 and 88 %. The exhaust air coming from the reactor containment contained comparatively more elemental iodine than the offgas of the turbine condenser. This is true also for measurements carried out in another BWR nuclear power station (not listed here).

If nuclear power stations were completely equipped with deep bed filters to remove radioiodine from all the exhaust air and gas, the occurrence of elemental iodine in the gaseous releases of the stations would be practically impossible. If this can be proved to be true and if, in addition, it can be excluded with sufficient certainty that the residual amount of iodine, which has penetrated through the filters and is therefore difficult to remove, is converted into easily adsorbed iodine on the transport to the point of impact, a much lower deposition velocity for the airborne fission product iodine can be used compared with elemental iodine. As a consequence, the contribution of the airborne pathway to the

Table VII: Iodine species released by different boiling water reactors +)

^{131}I as	Measuring point: end of offgas delay line of turbine condenser				Measuring point: ventilation duct, exhaust air	
	Reactor No. 1 ++)		Reactor No. 2 ++)		Reactor No. 2 ++)	
	Percent of total iodine 1st meas- urement	2nd meas- urement	Percent of total iodine 1st meas- urement	2nd meas- urement	Percent of total iodine 1st meas- urement	2nd meas- urement
Particles +++)	< 0.1	< 0.2	< 0.1	~ 0.04	12.0	10.3
I_2	0.06-0.1	10.5	22.0	21.7	57.9	29.3
HOI	12.5	22.9	21.8	43.1	12.6	21.7
Organic iodine	87.5	66.4	56.2	35.2	17.5	38.7

+) For more detailed information about reactors, see Table V.

++) Consecutive numbering as in Table V.

+++) This may also be elemental iodine in some cases.

calculated thyroid dose is probably at least one order of magnitude lower, and the restrictions imposed upon the construction of several nuclear power stations on one site because of the release of ^{131}I could be dropped.

The installation of deep bed iodine filters in modern nuclear power stations (one example is shown in Fig. 2) must be regarded as a decisive step towards reducing the environmental impact which, however, can exercise its full impact on the licensing procedure only if the iodine species emitted and their transport and removal behavior are known. Studies on the identification of the iodine species emitted, the elucidation of their transport and removal behavior and their significance for the pasture-cow-milk pathway are urgently recommended. As a first step in this field the usefulness of discriminating iodine samplers should be proved. It is suggested that this proof be produced by indicating a separation factor $\angle 187$ to describe the selectivity of the iodine collector for a combination of the most favorable and the most adverse conditions of removal of the different types of iodine (within the range of parameters to be expected in the exhaust air to be studied). When the existence of a suitable unit for selective iodine determination can be assumed, measuring programs should be carried out to measure the composition of the fission product iodine mixture at the point of emission and, if possible, also at the point of impact.

The direct correlation between the source strength of the fission product iodine mixture, its composition at the point of emission and its deposition onto green plants and the concentration in milk, respectively, will be possible only in a relatively small number of cases by the detection techniques now available, because the limits of detection at the point of impact will practically never be reached when most of the exhaust air is filtered. The author does not expect that a sufficient increase in sensitivity of the methods of detection will be achieved within a foreseeable period of time, especially if one takes into account the extremely low iodine emissions of modern nuclear power

stations. For this reason, it will be necessary to additionally clarify the behavior of iodine compounds on their transport pathways in a number of laboratory experiments using identified penetrating iodine compounds at extremely low bulk concentrations, but suitable specific activities.

In view of the siting problems already existing and the further advancement of nuclear energy, the author thinks these studies should be carried out with high priority and with the necessary expenditure in terms of manpower and finance.

3. Iodine Sorption Materials

3.1. Activated Carbon

Nuclear power stations now almost exclusively use impregnated activated carbon for the removal of radioiodine. Impregnation has turned out to be necessary in order to be able to remove organic iodine species, such as methyl iodide, under high humidity conditions. This is done by means of isotopic exchange or the generation of solid chemical compounds. Fig.3 shows the penetration of an unimpregnated type of activated carbon relative to ^{131}I present as elemental iodine (bottom curve) and methyl iodide (top curve). The plot shows the penetration as a function of the bed depth and the residence time, respectively. While ^{131}I in the form of methyl iodide was practically not retained at all, the curve for the I_2 penetration shows a steep drop with the bed depth. The penetration down to a bed depth of approximately 2 cm is described by a straight line on the semi-logarithmic plot which levels off after falling below some 0.1 %. This gives rise to the conclusion that elemental iodine (straight section of the curve) had been contaminated by one or more iodine compounds which, after removal of the elemental iodine, determined the removal behavior of the residual radioactivity and could not be filtered out with the activated carbon available. This may be a matter of methyl iodide or other iodine compounds produced in small fractions during the preparation of elemental iodine or in the test apparatus.

At the author's laboratory several hundreds of such removal profiles have been compiled, most of which were produced with a mixture of $\text{CH}_3^{131}\text{I}$ and $\text{CH}_3^{127}\text{I}$ as the test agent in experiments in which deep filter beds consisting of various kinds of activated carbon or inorganic iodine sorption materials had to be tested. Within the framework of these studies, the type and concentration of the test agent (elemental iodine and methyl iodide, respectively), loading of the iodine sorption material, humidity of the air, temperature, air velocity and duration of the experiment were varied over a broad range. In all cases the removal profile was found to flatten out and the removal efficiency of the sorption material was found to decrease after a large (approximately 99.9-99.99 %), mostly not very different fraction of the test agent had been removed. Flattening of the curve occurred at various concentrations of the test agent in the sorption bed. The following conclusions can be drawn from all these experiments:

1. There is no fixed concentration limit for the removal performance of impregnated activated carbon in the areas of low and very low concentrations.
2. The curve of the removal profile is determined by penetrating iodine compounds after the larger fraction of the test agent has been removed, these iodine compounds being produced in the preparation of the test agent or generated on the transport route or in the activated carbon itself. The percentage fraction of the penetrating compounds is particularly high whenever the preparation of the test agent is done in the carrier-free technique.
3. An extrapolation of the linear section of the curve of the removal profile to greater depths of the filter bed (beyond a decontamination factor of approximately 10^3 to 10^5) as a rule gives rise to removal factors which cannot be achieved in practice or in the laboratory because of the unavoidable occurrence of penetrating iodine compounds.

3.1.1. Removal of Elemental Iodine by Activated Carbon

Elemental iodine is bound to activated carbon by adsorption and chemisorption. Because of the strong adsorptive binding of elemental iodine, the high porosity, the advantageous porous structure and the extremely large inner surface of the activated carbon used (approximately 800 - 1000 m²/g according to BET), an important removal mechanism is constituted by the very physical process of adsorption, even in humid air.

Functional groups on the surface of the activated carbon e.g., phenolic and other alcoholic hydroxyl groups, may react with the iodine and create chemical bonds. The importance of the potassium content and the "pH level" of activated carbon will be referred to below.

The evaluation of the trapping of elemental radioiodine on activated carbon with a specific removal efficiency or decontamination factor independent of the sweeping time is based on an irreversible adsorption, which can be assumed to exist under conditions of relatively low loading of the activated carbon with the very firmly adsorbed iodine in the low and intermediate temperature ranges. This is true under conditions usually existing in normal operation in the exhaust air and exhaust gas systems of nuclear power stations. By conversion of the iodine bound to activated carbon into more highly volatile iodine compounds, e.g., under high dose rates of ionizing radiation and by temperature increases, iodine already trapped may be desorbed, which makes the real removal efficiency dependent on the sweeping time.

3.1.2. Removal of Methyl Iodide by Activated Carbon

The adsorption of methyl iodide on activated carbon is greatly impaired by the simultaneous adsorption of water vapor from moist air. If the humidity of the air is low, the water uptake is relatively small because of the generally hydrophobic nature of activated carbon, but it greatly increases in the range of intermediate humidity levels of the air, because capillary condensation occurs in micropores and, as the partial pressure of water vapor increases, also larger pores are filled with water. The number of hydrophilic

centers on the surface of the activated carbon (e.g., OH-groups) has a major influence on the adsorption of water vapor.

It depends on the base material, the method of preparation and, if applicable, on the impregnation of the activated carbon. Unimpregnated activated carbon does not produce any meaningful removal performance at relative humidities of the air >30 % and at room temperature; as the exposure time rises, at least part of the methyl iodide is desorbed again. For this reason, the performance of activated carbon must be improved by the necessary types of impregnation for proper removal of methyl iodide by chemisorption and isotopic exchange, respectively [19, 20, 21]. The types of activated carbon now used in the iodine filters of nuclear power stations are impregnated with iodine salts ($K^{127}I$) and I_2 or triethylene diamine. Also mixtures of the two impregnations are known. The percentage fraction of the impregnating agent is between 0.5 and 5 wt. %.

In the removal of ^{131}I loaded as $CH_3^{131}I$ by KI-impregnated activated carbon the following exchange process occurs which, correspondingly, also applies to other iodine isotopes:

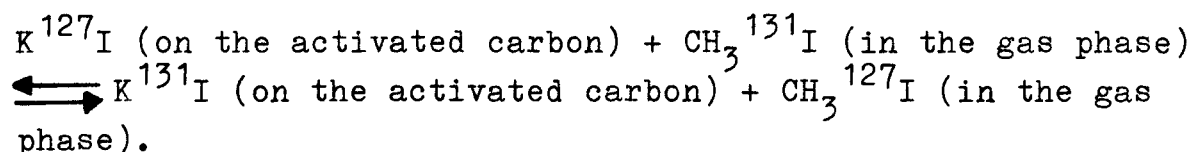

Accordingly, radioactive methyl iodide enters the activated carbon bed and leaves it again as inactive methyl iodide.

A small fraction of the methyl iodide may be decomposed on the activated carbon by hydrolysis, the iodine bearing hydrolysis products are adsorbed.

The steps determining the rate of the isotopic exchange are given by the diffusion of the active methyl iodide to a point of the surface of the activated carbon capable of exchange, and the desorption of the inactive CH_3I molecule from this point. The decontamination factor that can be achieved by isotopic exchange is determined by the ratio between inactive ^{127}I and ^{131}I on the surface of the activated carbon. As a result of the relatively large quantities of ^{127}I on the surface of the activated carbon which compare

with extremely small quantities of adsorbed ^{131}I (as methyl iodide), the exchange equilibrium as mentioned above is shifted to the far right-hand side. If the residence time of the contaminated air in the activated carbon bed is sufficiently long, a large fraction of ^{131}I from $\text{CH}_3^{131}\text{I}$ can be exchanged and, consequently, a high decontamination factor can be achieved.

One impregnating agent for the removal of methyl iodide by the generation of solid compounds is triethylene diamine (TEDA):

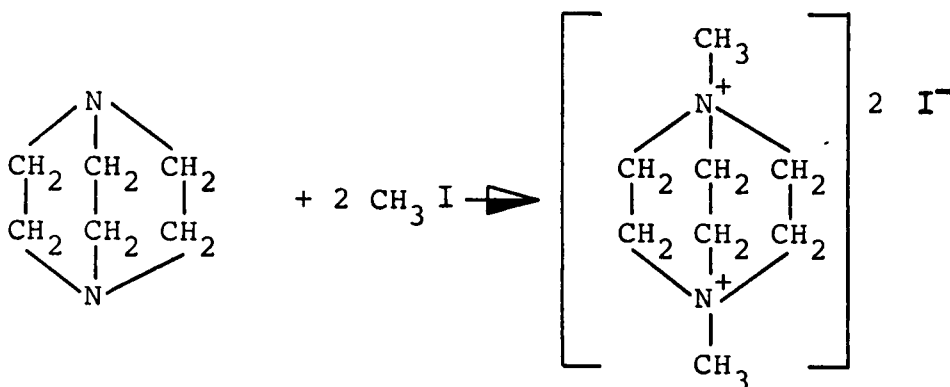

The removal effect is due to the conversion of methyl iodide into a quaternary ammonium salt bound to carbon.

The reactions formulated for methyl iodide to some extent also apply to other organic iodine compounds, e.g., higher alkyl halides.

Iodine impregnated activated carbon should be loaded only up to a maximum of 100 μg of $\text{CH}_3\text{I}/\text{g}$ of carbon, TEDA impregnated activated carbon only up to 1 mg of $\text{CH}_3\text{I}/\text{g}$ of carbon. Higher loading may be permissible, but it requires additional experiments to back up the measured results.

3.1.3. Removal of Hypoiodous Acid by Activated Carbon

One question which is still largely open is that of the removal of hypoiodous acid by means of activated carbon. Even the preparation of radioactively labeled hypoiodous acid and its transformation into the vapor phase with the separation of elemental iodine presents major difficulties. According to the author's laboratory experience it is not

certain that satisfactory yields can be achieved. So far, only two laboratories have made available measured results from sorption materials. Nothing is known about the reproducibility of the measured results. Kabat [227] in 1974 published measured data which indicate a removal behavior of hypiodous acid less favorable than that of methyl iodide. Above all, the fraction of iodine radioactivity desorbed again from the activated carbon bed per unit time is rather high, reaching levels of up to 0.04 %/h in laboratory experiments (with a test bed of 6 cm depth, at room temperature, 50 % r.h., a face velocity of 22 cm/s and a concentration of carrier-free HOI of 10^{-1} $\mu\text{Ci } ^{131}\text{I}/\text{m}^3$ of air).

Activated carbon impregnated with iodine salt on TEDA, according to Kabat, retains hypiodous acid more efficiently than others. The mechanism of trapping hypiodous acid vapor on activated carbon has not yet been verified. One possible explanation would be the decomposition of the adsorbed HOI molecules on the surface of the activated carbon, disproportionation of HOI to other oxidation stages and salt formation. Since obviously the percentage fraction of hypiodous acid in the exhaust gas can reach quite significant levels (see Table VII), the actual problem continues to exist, even if there is removal by deeper activated carbon beds, because of the relatively high desorption rate. With respect to the environmental contamination level it must be assumed that desorbing hypiodous acid, while on the route from the filter through the stack and into the atmosphere up to the point of impact, decomposes. This will give rise to the formation of easily adsorbed iodine and, hence, might result in an increased exposure through the pasture-cow-milk pathway. Further investigations are urgently recommended.

3.1.4. Iodine Removal by Activated Carbon as a Function of Concentration

As early as in 1965 information was quoted in the literature on the dependence on concentration of the removal efficiency of iodine sorption material in the low

concentration region $\angle 237$. In 1972, that is, at a time when much more experience and better experimental and preparative techniques were available, a study was published in which a reduction of the removal efficiencies of several consecutive layers of iodine sorption material to radioactively labeled methyl iodide was found $\angle 247$.

If this decrease of the removal efficiency were due exclusively to the existence of low concentrations, it would be necessary, because of the very low, but very different and highly variable fission product iodine concentrations in the exhaust air of a nuclear power station, to discontinue quoting a fixed (minimum) removal efficiency of an iodine filter. The repercussions this would have upon licensing procedures already under way and on operating licenses already granted can hardly be estimated.

In the light of experimental experience including the assessment of removal profiles down to 9.4×10^{-7} $\mu\text{g CH}_3\text{I}/\text{m}^3$ $\angle 257$, a bulk concentration dependence of the removal efficiency in the range of very low concentrations is excluded by the author.

The so-called concentration effects are attributed to the presence of other iodine compounds difficult to remove, which remain either after the more easily removed iodine forms have been filtered out and then determine the removal behavior of the residual amount of iodine, or are generated in the sorption material in the course of the removal reactions. The problem of removing very low iodine concentrations has other constraints also in the natural airborne iodine concentration. This may be on the order of approximately 10^{-3} $\mu\text{g}/\text{m}^3$ in Germany $\angle 267$. Lower iodine concentrations therefore usually will be found not in the filter influent but only after passage through part of the activated carbon bed and in the exhaust air of the iodine filter, respectively. J.L. Kovach and J.R. Hunt $\angle 277$ in 1974 published data at the 13th AEC Air Cleaning Conference which indicated that in the presence of fission product iodine removal efficiencies were measured in the region of

natural iodine concentrations of the air which did not differ from the results in the mg/m^3 range. At the same conference, a paper was published [28] in which an increase in the removal performance was found with decreasing radioactivity concentration in air of the methyl iodide used as a test substance. The radioactivity concentration level beyond which a major decrease of the removal performance of KI-impregnated activated carbon was found was stated to be 10^{-6} Ci/m^3 for an activated carbon bed $1/2$ " deep. In deeper beds the concentration limit at which a certain removal efficiency was still attainable moved upward. The experiments were carried out at a low relative humidity of the air of 25 %. Radioactivity concentrations of 10^{-6} Ci/m^3 and more will rarely be reached in the exhaust air of nuclear power stations in normal operation but, on the other hand, can easily be set in laboratory experiments. A number of other results of the paper referred to above contradict the present state of the art which, however, is based primarily on removal experiments at higher humidities of the air. The removal efficiency was independent of the type and grain size of the activated carbon in the range of radioactivity concentrations studied between $2.3 \times 10^{-9} \text{ Ci/m}^3$ and $1.6 \times 10^{-4} \text{ Ci/m}^3$, but was dependent on the radioactivity concentration in the untreated air, the face velocity, relative humidity and the bed depth. It is evident from the data of the unabbreviated original study [29] that the total radioactivity used in the intercomparison tests had been too low to allow activated carbon of different types to be tested. The limit of detection of the activity occurring on the clean air side had been underrun in each individual experiment; in the grain size studies the activities measured were slightly above the limit of detection. Unfortunately, the study quoted does not include any indication of the bulk concentration of methyl iodide, which is important for adsorption events. Experiments carried out at the author's laboratory showed no change in the removal efficiency of impregnated activated carbon in the region of activity concentrations $>10^{-6} \text{ Ci/m}^3$. Even at very high activity

concentrations of the intake air there was no reduction in the removal efficiency of activated carbon beds 2.5 to 10 cm deep.

Table VIII shows the respective values obtained at high relative humidities of the air (98 - 100 %), in contrast to Bellamy /287.

Table VIII: Removal efficiencies for ^{131}I as $\text{CH}_3^{131}\text{I}$ at high and intermediate radioactivity concentrations in the influent air

1 % KI-impregnated activated carbon pellets, diameter 0.8 mm, loaded with 1 ± 0.2 Ci and 3 ± 0.6 mCi/g of carbon, respectively, (mixed with a total of 20 ± 4 μg of $\text{CH}_3^{127}\text{I}$), filtered laboratory air, 30°C , 98 - 100 % r.h., face velocity 25 cm/s.

Bed depth [cm]	Residence time [s]	Radioactivity concentration	
		112 Ci $\text{CH}_3^{131}\text{I}/\text{m}^3$	0.33 Ci $\text{CH}_3^{131}\text{I}/\text{m}^3$
		Removal efficiency in %	
2.5	0.1	50.8	50.2
5.0	0.2	78.5	77.3
7.5	0.3	92.0	88.8
10.0	0.4	97.5	94.5

With respect to the variation of the radioactivity concentration, the differences in removal efficiencies as shown in Table VIII are on the order of the experimental error. At the high radioactivity concentrations very small activated carbon beds (dia. 6 mm) had to be used in order to prevent the total amount of radioactivity used from becoming too large.

Since medium to high humidities of the air must be assumed in the exhaust air of nuclear power stations, for which the removal efficiencies are lower than those at 25 % r.h., and

since the physical adsorption of methyl iodide does not present a major removal mechanism in the range of high humidities, the author does not regard the results shown in the work by Bellamy as a basic objection against the measured data now generally used for the design of iodine filters.

3.2. Status of Fission Product Iodine Removal by Activated Carbon under Normal Operating Conditions of Nuclear Power Stations

Elemental iodine can be removed by activated carbon so efficiently that no problems must be expected under the conditions existing in the exhaust air of nuclear power stations in normal operation. This assumes that no temperatures occur in the exhaust air at which there would be major desorption of radioiodine from the iodine filter. Also methyl iodide can be removed sufficiently well under the conditions mentioned above by means of activated carbon with a suitable impregnation.

Opinion on the removal of fission product iodine at very low concentrations has not yet reached a firm consensus. The present procedure of extrapolating laboratory data obtained generally at higher bulk and radioactivity concentrations when compared with exhaust air filtration is justified only if these data are on the safe side, that is to say, exclude major drops below or above the range of concentration selected for testing in the laboratory. In the light of the experimental experience referred to above, which includes the measurement of removal profiles at extremely low and high radioactivities and bulk concentrations, the author is convinced that a drop in the removal efficiency as a result of concentration effects can be excluded, unless the activated carbon is loaded with excessive amounts of iodine and methyl iodide, respectively. This must in no way be expected to occur with iodine filters in the normal operation of nuclear power stations. As mentioned above, the lower concentration limit is given by the natural iodine content of the filter intake air, so the extremely low bulk concentrations of fission product iodine practically have no

impact.

In the author's opinion, the removal of elemental iodine and methyl iodide can thus be regarded as having been solved for normal conditions of nuclear power plant operation. The removal efficiency of activated carbon relative to these iodine compounds is sufficiently well known and easy to measure. EURATOM intercomparison tests will be able in the long run to bring about a harmonization of the test methods so as to make the results of tests carried out by the participating laboratories generally valid. Even now intercomparison tests show relatively good agreement of the results achieved by European and overseas laboratories.

The questions remaining open on the iodine removal with activated carbon from the exhaust air of a nuclear power station during normal operation are due to the existence of more penetrating iodine compounds, which also includes hypiodous acid, and above all the poisoning and aging of activated carbon. This latter point will be referred to separately.

3.3. Status of Fission Product Iodine Removal during Accidents

Under conditions of a loss-of-coolant accident higher exhaust air temperatures must be expected as a result of the release of coolant into the atmosphere of the reactor containment and the reactor building, respectively. In a pressurized water reactor containment a maximum of approximately 150° C must be assumed. In certain high temperature reactors there may be temperatures of a few hundred ° C inside the reactor building for short periods of time.

Depending upon the extent of the accident, the humidity of the air will increase greatly in the containment of water cooled reactors and the dew point may be underrun so that condensation will start. Spray systems in addition can be used to spray large amounts of water as droplets into the pressurized containment or the compartments of a pressure suppression system. If major amounts of the fission product

iodine and other fission product inventories are released from the reactor core as the accident goes on, the filters are likely to be heated by the decay heat of the radioisotopes removed, and also they will accumulate higher iodine loadings. The impact of radiation upon the iodine to be removed, the activated carbon and airborne pollutants may give rise to the formation of iodine compounds difficult to remove. The high temperature and perhaps also fires will give rise to major releases of filter pollutants. Almost all these events aggravate the removal of radioiodine. For this reason, modern reactors have iodine filters for operation in accident situations which are removed from the direct exposure to the atmosphere of the primary containment and are connected only to the annulus surrounding the primary containment and separated from it, and to some other secondary containment, respectively. The influence of different accident conditions on iodine removal will be outlined below.

3.3.1. Removal of Fission Product Iodine by Activated Carbon at Elevated Temperatures

If air is used as the sweep gas, higher temperatures give rise to such events as -

desorption of fission product iodine; increase in the oxidation rate of activated carbon up to the point of ignition; oxidation of the impregnation, e.g., from KI to elemental iodine; desorption of the iodine and TEDA impregnating agents; ignition of desorbing TEDA vapors (above approximately 190° C); reaction between organic compounds adsorbed and elemental iodine to produce easily desorbed iodine compounds.

The ignition temperatures of activated carbons vary greatly and depend on a multitude of boundary conditions. Below 200° C ignition of activated carbon in air is relatively infrequent.

Because of the desorption behavior, operating temperatures of 120° C are regarded as the upper temperature limit for the use of activated carbon in the Federal Republic of Germany, unless the iodine desorption by the respective

batch of activated carbon had been examined at higher temperatures.

The results of a large number of studies indicate that elevated temperatures may cause major desorption both of the fission product iodine already collected on the activated carbon and of the impregnation. As a result of the high vapor pressure of iodine at elevated temperatures an activated carbon bed can no longer be regarded as a filter with a removal efficiency defined so as to be almost independent of the sweeping time, but must rather be regarded as an adsorption bed with relatively long retention times for fission product iodine. The desorption of fission product iodine and iodine impregnation differs greatly in activated carbon made from different materials. Activated carbon made of coconut shells as a rule will retain iodine much better at elevated temperatures than will activated carbon based on hard coal, wood or petroleum.

Apart from the basic material, the extent of desorption depends on the type and batch of activated carbon, the impregnation, depth of the filter bed, iodine loading and such parameters as temperature, humidity of the air, air velocity and desorption time. Evans ³⁰⁷ in testing desorption on activated carbon made of coconut shells found desorption levels of 12.82 and 0.023 %, respectively, in two different batches of activated carbon of the same type, although they had been made by the same manufacturer (test conditions: loading with elemental iodine for 10 minutes; four hours of desorption at 180° C in air of < 1 % r.h.).

Experiments with KI-impregnated peat based activated carbon exposed to $\text{CH}_3^{131}\text{I}$ ³¹⁷ showed a desorption of 0.2 % at 150° C and 35 % at 200° C after twelve days of sweeping with dry air. One percent of release by desorption was exceeded at 200° C after 24 hours and at 150° C after 18 days of desorption time (linear air velocity 25 cm/s; depth of bed 10 cm). Extensive data material can be found in reference ³²⁷.

Impregnation of activated carbon with an aqueous KOH-I_2

solution was able to greatly improve iodine retention at elevated temperatures. An atomic ratio of $I/K < 1$ led to positive results. The pH-level of the aqueous extract of the activated carbon should be high. The action of KOH-impregnation can be explained by the following reaction:

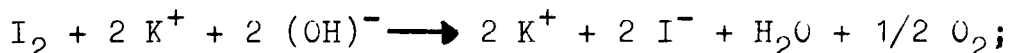

In this way, easily desorbing elemental iodine is transformed into the iodide ions of a salt with a negligible vapor pressure. Under alkaline conditions also other iodine salts, such as iodates, periodates and hypiodites, may be produced on a small scale, but they are probably not stable on the surface of the activated carbon at elevated temperatures. The decisive factor in the changed desorption behavior is the transformation of elemental iodine into the iodide ion.

The good iodine retention at elevated temperature of most types of activated carbon made of coconut shells according to Evans is due to the high content of K^+ and the pH level, which is in the alkaline region. Activated carbon of different origins can be improved by impregnation with $KOH-I_2$ and then exhibit correspondingly lower desorption rates. However, the increased content of K-salts greatly lowers the ignition temperature of activated carbon, for instance, from 475 to 330° C.

3.3.2 Removal of Fission Product Iodine by Activated Carbon under the Influence of High Radiation Dose Rates

Following the removal of major amounts of fission product iodine in an accident, the iodine sorption materials and the materials adsorbed are exposed to a high dose rate of the radiation generated by the radioactive decay of the fission product iodine trapped. Additional radiation exposure may result as a consequence of the γ -radiation of aerosols collected in the aerosol filter upstream of the sorption section of the iodine filter. Moreover, there may be radiation exposure due to radioactive noble gas isotopes passing the iodine filter and in this way becoming temporarily adsorbed on the surface of the activated

carbon.

In the experiments by Evans 337, about which we will report below, pre-irradiation of unloaded activated carbon had no major impact upon its performance in the subsequent removal test.

The simultaneous presence of iodine, activated carbon and water vapor (moist air) produces organic iodine compounds of which methyl iodide (CH_3I), ethyl iodide ($\text{C}_2\text{H}_5\text{I}$), diiodomethane (CH_2I_2) and vinyl iodide ($\text{C}_2\text{H}_3\text{I}$) have been identified so far. The reaction occurs through the formation of radicals. Conversion of the iodine already collected on the activated carbon into volatile iodine compounds will cause desorption. This will be enhanced by high humidity of the air. For instance, at a γ -dose rate of 1.5×10^7 rad/h (^{60}Co source) over a period of 5 hours, penetrations of activated carbon beds for ^{131}I were found to be between 0.3 and 0.003 %, while the control experiments excluding radiation in most cases indicated penetrations < 0.001 %. These were the other test conditions:

Loading with 0.7 mg of I_2 per gram of carbon, loading time 1 hour, moist air of approximately 75 % r.h. and 80°C as the carrier and sweep gas, respectively, face velocity 28 cm/s, 2.5 cm depth of bed of the activated carbon tested, 1 hour of loading time, 4 hours of sweep time.

Impregnated carbon exhibited a much lower penetration than non-impregnated carbon; the lowest desorption rate was measured on a TEDA-impregnated coconut shell type of activated carbon. Activated carbon aged in filter operation showed greatly increased desorption rates. Lorenz et al. 347 investigated the penetration of activated carbon beds when loaded with a mixture of ^{127}I - ^{132}I of high specific activity (mostly approximately 50 Ci of ^{132}I /g of carbon) and found desorption rates comparable with the levels indicated by Evans.

3.3.3. Inorganic Sorption Materials for Iodine Removal at High Temperature and High Dose Rates

It has been shown in the previous sections that the use of activated carbon under these conditions is bound to give

rise both to the desorption of iodine and to the formation and subsequent desorption of iodine compounds difficult to remove. Since there is also a fire hazard, experiments have been going on for some time on the development of non-burnable, temperature and radiation resistant inorganic iodine sorption materials. Silver or silver plated copper wire remove elemental iodine with high removal efficiencies on their fresh metal surfaces, but they fail in the presence of iodine as methyl iodide. If the silver is chemically bound in molecular sieves, for instance the Linde molecular sieve of the 13 X (LMS 13 X-Ag) type, and activated in this way it is a suitable reaction partner also for removing iodine in the form of methyl iodide [35]. I_2 and alkyl halides, such as CH_3I , will be transformed into silver iodide.

The silver forms of molecular sieves (silver zeolites) can be used as iodine sorption materials also at higher humidities of the air and, in dry gases, at very high temperatures. Excellent removal efficiencies have been measured in dry air up to $650^\circ C$ [36].

Silver zeolites are very costly because high silver contents are necessary to achieve good removal efficiencies and it is mainly the silver in the outermost layer which reacts during the usual short residence times.

Metal kations other than Ag^+ in zeolites give rise to lower removal efficiencies and fail practically completely in the removal of methyl iodide from humid air.

The impact of radiation on silver zeolites turned out to be insignificant in experiments with an integrated dose of up to 10^8 rad, as far as the removal efficiency in the subsequent methyl iodide removal test is concerned [24]; however, in a removal experiment at high γ -dose rates there was also desorption [33], and there is a lack of sufficient data on the behavior under irradiation of the silver iodide imbedded in the molecular sieve. Other non-burnable materials which can be used to remove iodine and methyl iodide are produced on the basis of silicic acid and aluminum oxide and impregnated with silver nitrate. One example is the AC-6120 iodine sorption material developed jointly by Gesellschaft

für Kernforschung and Bayer, Leverkusen /37, 38/. This material will attain relatively high removal efficiencies with relatively small amounts of silver and, in addition, lends itself to application in the NO_x -bearing exhaust gases of a reprocessing plant. Another material, for instance, is the NACAR GX 135 sorption material, a silver nitrate impregnated alumino silicate.

Silver nitrate reacts with elemental iodine according to the following formula /39, 40/:

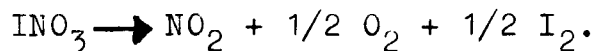
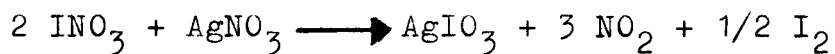
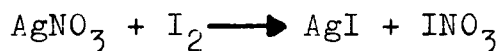

The iodine is bound as silver iodide and silver iodate.

Methyl iodide and other alkyl halides react with the silver nitrate impregnation according to /41, 42/:

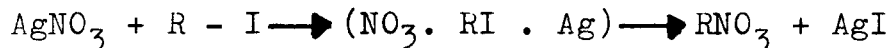

also giving rise to silver iodide.

The end products of the reactions of iodine or methyl iodide with silver and silver nitrate, respectively, are stable and hardly soluble, which makes them useful for storage.

The limits to the use of silver nitrate impregnated iodine sorption materials are constituted by the solubility in water of the impregnation and the decomposition of silver nitrate at higher temperatures. For instance, if AC 6120 is exposed to hot air for prolonged periods of time, an upper temperature limit of 250°C should not be exceeded /43/; higher temperatures are permissible for short periods of time /44/.

As can be assumed in the light of pre-irradiation studies, the influence of γ -radiation on the removal efficiency of AC 6120 is very slight /45/. Iodine penetration in the loading and desorption test under irradiation approximately corresponds to that of impregnated activated carbon on a coconut base /46/.

3.3.4 Removal of Fission Product Iodine at High Humidity of the Air and from Saturated and Superheated Steam

Brief reference has already been made in Section 3.1.2. to the influence of the adsorption of water vapor upon the removal of methyl iodide. In Table IX the removal efficiencies are listed which were obtained with KI-impregnated activated carbon for ^{131}I loaded as $\text{CH}_3^{131}\text{I}$ at room temperature, as a function of the relative humidity of air. At the time it was exposed to methyl iodide, the activated carbon was in equilibrium with the water vapor content of the air.

Table IX: Removal efficiencies of Norit RX-C8-C activated carbon (immersion impregnated with 1 % KI) for ^{131}I (as $\text{CH}_3^{131}\text{I}$) at different relative humidities of air

Activated carbon : extruded, pellet diameter 0.8 mm, 1 % KI-impregnated.

Carrier gas: humid air 30° C, prefiltered by a HEPA filter.

Conditioning (carrier gas only): ≥ 22 h.

Loading (test agent + carrier gas): 1 h.

Additional sweep time (carrier gas only): ≥ 20 h.

Test medium: 70 ± 10 μg $\text{CH}_3^{127}\text{I}$ per gram of carbon, mixed with approximately 10 μCi $\text{CH}_3^{131}\text{I}$ per gram of carbon (loading calculated for 10 cm bed depth).

Pressure drop: Approximately 90 mm of water at a face velocity of the air of 25 cm/s, room temperature and atmospheric pressure (measured over a test bed of 10 cm length).

Relative humidity of the air % /7	Removal efficiencies (η) in %			
	Bed depth in cm			
	2.5	5.0	7.5	10.0
	Residence time in s			
	0.1	0.2	0.3	0.4
25	99.62	99.9997	> 99.9999 ^{+))}	> 99.9999 ^{+))}
40	99.37	99.9983	99.9999	> 99.9999 ^{+))}
55	98.8	99.942	99.9981	99.9999
70	96.1	99.914	99.9974	99.9998
85	95.6	99.79	99.9947	99.9997
95	85.7	98.6	99.87	99.988
98 - 100	80.4	97.2	99.5	99.92

^{+))} Penetrated radioactivity below detection limit.

It can be seen from the data listed in Table IX that a bed depth of approximately 7.5 cm must be chosen for $\geq 99\%$ removal of ^{131}I as $\text{CH}_3^{131}\text{I}$ with the very high, that is, unfavorable relative humidity of the air of 98 - 100 %, while only 2.5 cm bed depth is sufficient for a relative humidity of 40 %. The removal of elemental iodine is much better over the whole range of relative humidities of the air. An assumption which is on the safe side is that of a removal higher by one order of magnitude; in practice, removal efficiencies for elemental iodine of $>99.99\%$ may be expected at 5 cm bed depth and humidities of the air of $<100\%$. Various types of TEDA-impregnated activated carbon show an excellent removal capability for I_2 and methyl iodide in moist air.

Data from removal experiments with pre-humidified or dry activated carbon as the sorption materials and humid or dry air as the carrier gases for methyl iodide are shown in Fig. 4. The curves indicate that the penetration of the activated carbon after pre-humidification (the water vapor adsorption equilibrium on the carbon had been established for 98-100 % r.h. and 30°C) relative to radioiodine in

dry air ($\ll 30\%$ r.h.) and moist air (98 - 100 % r.h.) is practically the same up to the point at which low penetration is reached (0.01 %), but then the removal profile obtained in moist air bends off earlier. The latter fact proves the existence of more strongly penetrating iodine components in moist air.

If dry activated carbon is exposed to methyl iodide in humid air for short periods of time (to prevent larger quantities of water from being adsorbed by the activated carbon), much lower penetrations result, but the curve also shows a bend once the largest part of the activity (approximately 99.98 %) has been removed. The conversion of approximately 0.02 % of the methyl iodide into a compound difficult to remove must be assumed to take place in a reaction with the water vapor of the air.

Experiments using dry activated carbon and dry air (not indicated in Fig. 4) also resulted in a high removal efficiency. Compared with the exposure to moist air, the curve showed a bend at a lower point so that, on the whole, a lower penetration through the respective bed depth of activated carbon was obtained.

In the light of the curves shown in Fig. 4, the following information can be presented on the removal efficiency of iodine filters:

- Water vapor adsorption onto the activated carbon will result in increased penetration.
- A filter pre-humidified by adsorbed water will remove radioiodine added as methyl iodide with a reduced removal efficiency even from dry air.
- If a dry activated carbon filter is exposed to radioactive methyl iodide in moist air, an initially high removal efficiency may be expected which decreases only as the amount of water adsorbed by the activated carbon increases.
- Most adverse to high removal efficiencies is loading with radioactive methyl iodide of pre-humidified activated carbon in the presence of a high relative humidity of the air.

From other removal experiments not referred to in detail in this report it is evident that

- activated carbon whose macro-pores were filled by condensed water (e.g., because the temperature in the activated carbon had fallen below the dew point) loses its capability to remove fission iodine as methyl iodide to a satisfactory degree.

Also molecular sieves of the silver type showed an increase in penetration as the relative humidity of the air increased $\angle 32, 36, 477$. The penetration of AC 6120 rises so rapidly above approximately 70 % r.h. that a limitation of the maximum relative humidity of the air to 70 % is probably advisable $\angle 257$.

Carrying out iodine removal tests at elevated temperatures, gas humidities and pressures with humidities controlled sufficiently accurately is extremely difficult. For this reason, only very few experiments have ever been performed. What is missing, above all, is data on iodine removal on sorption materials during the prolonged action of saturated and superheated steam at elevated temperatures. It may be assumed that even below 100 % r.h. there is a considerable transport of impregnating agent, perhaps as a consequence of chemical reactions in the activated carbon, which can give rise to a reduction in removal efficiency and to increased desorption.

Reference is made to the iodine desorption at higher temperatures occurring already in dry air (Section 3.3.1.).

Some data on the behavior of impregnated activated carbon in air-steam mixtures at elevated temperatures and pressures can be taken from the work by Adams et al. $\angle 47, 48, 497$. However, only experiments of relatively short duration were carried out which lasted for a total of approximately 5 hours for loading and desorption. The factor studied was the removal of ^{131}I (as methyl iodide) in air-steam mixtures up to 100 % r.h. at temperatures up to 138°C and pressures ≤ 3.7 ata. Suitable types of impregnated activated carbon, such as the BC-727 type with iodine impregnation, showed good removal

efficiencies, e.g., 99.1 % for a bed of BC-727 5 cm deep, at a linear gas velocity of 21 cm/s and 89 % r.h. At even higher humidities of the air, the removal efficiencies were not too bad; as 100 % r.h. was approached, the removal efficiencies decreased. Control of the humidity of the air was unable to prevent occasional condensation in the activated carbon at humidities of the air as high as this. For this reason, some of the values measured show considerable scattering.

If the activated carbon was wetted by condensing steam, the removal efficiency decreased sharply. Flooding with condensing steam brought about a major loss in impregnation of the activated carbon due to washing out. Such conditions should on all account be avoided in practice, or their effects should be limited by preheating of the moist air, even if it is unavoidable that the temperatures in the activated carbon briefly fall below the dew point when a cold iodine filter is exposed to warm moist air.

More data on the influence of saturated steam on different iodine sorption materials can be taken from a study referred to above [247]. While, following a short-time exposure of AgX-zeolite to saturated steam at 139°C, the removal efficiencies measured were still high, e.g., 99.49 % at 5 cm bed depth and a face velocity of 26 cm/s, 5 hours of a preliminary treatment with saturated steam gave rise to a pronounced decrease of removal efficiency, both with different silver zeolites and KI-I₂-impregnated activated carbon. For AgX-zeolite there was a removal efficiency of only 66.22 % (depth of bed 5 cm, linear gas velocity 23 cm/s).

The author examined the removal efficiency of LMS 13 X-Ag after aging by exposing it to large quantities of superheated steam at 235 and 510°C for periods of 16 and 32 h, finding a decrease of the removal efficiency from 99.76 % (before aging) to 73.85 % (after 32 h of exposure to superheated steam of 235°C and 30 ata) and to 0.91 %, respectively (after 16 h of exposure to superheated steam of 510°C, 140 ata) [367]. The loss of removal efficiency

was due to a partial destruction of the lattice structure of the molecular sieve; in addition, the binder was attacked by the steam. After even longer periods of exposure the structure of the molecular sieves was destroyed altogether.

It should be investigated whether the use of harder zeolites with a higher Si/Al ratio than that of type X and the use of different binders could produce an iodine sorption material based on zeolite which would be more resistant to water vapor. However, zeolites with a lower content of aluminum show lower ion exchange capacities, which means that the attainable Ag content and hence the removal efficiency will be lower from the outset.

With respect to loading of iodine filters under accident conditions the author thinks that additional experiments with accurately controlled humidity of the gas and extending over a longer period of time are urgently needed. A combination of high humidity of the gas and high temperature is probably most difficult to control in the case of prolonged exposure periods of the iodine adsorption materials.

4. Requirements to Be Fulfilled by Iodine Filter Systems in Nuclear Power Stations

4.1. Ventilation Concepts and Filters for Normal Operation of a Nuclear Power Plant

The emission of fission product iodine in normal plant operation can be reduced considerably by the installation of filter systems, the use of clean sealing steam in valves and turbine bearings, degassing of condensers through an activated carbon adsorber, and by means of operational measures. Table II indicates calculated values describing the effects of the different systems and measures. It should be added that a number of more recent reactors are equipped with gland seal suction systems with iodine filters (not referred to in Table II) whose impact on the iodine release is probably comparable to that of the use of clean sealing steam, considering that these systems act on the same potential leaks.

The ventilation concept largely determines the design of filter systems for normal operation of a nuclear power plant. Ventilation concepts may be geared to two basically different ventilation principles, namely fresh air and recirculation air operation. The application of the fresh air principle is in general more capable of preventing the internal spread of contamination than is the recirculation air principle. However, relatively large amounts of air must be discharged to the outside. If the whole amount of exhaust air were to be filtered continuously, the expenditure involved in the filter systems would be very high. For this reason, when using the fresh air principle, usually a filter system is installed which is operated only whenever airborne activity occurs or before potentially contaminated rooms are entered, while otherwise it is bypassed (standby filter system). Since, in addition, the removal of heat from those areas of the containment which contain plant components carrying coolant at high temperature can be coped with only by using very large amounts of air, ventilation concepts are frequently found which are a mixture of the recirculation air and fresh air systems. The heat in these systems is mostly removed through the recirculation air coolers.

To reduce radioactivity releases, additional measures and systems are mostly applied when the fresh air principle is used, such as the assessment of potential points of leakage by means of a gland seal suction system equipped with iodine filters. To restrict the dimensions of the exhaust air filters it is also possible to run the exhaust air of single groups of rooms separately so that, if need be, the filters can be connected to specific groups of rooms and in this way the filtration of large amounts of exhaust air is avoided.

In the Federal Republic of Germany, the fresh air principle has been applied only in boiling water reactors. However, the most recent development even with boiling water reactors has led to the application of the recirculation air principle throughout.

It will not be attempted at this point to compare the different pros and cons of fresh air and recirculation air systems. However, a few points should be mentioned which are of importance with respect to iodine filtration.

Very frequently, the same standby filter systems must be available for a multitude of plant requirements, for instance, in a specific type of boiling water reactor, to clean the air from the foundation of the annulus, the control rod drive room, the drywell, the reactor operating console and, in addition, from other rooms and groups of rooms of the reactor building in which there may be coolant leakages. The reliability of the iodine filters of such a system in case of a reactor accident is therefore very limited; pre-loading by pollutants stored before the filter is needed because of an accident is a condition which cannot be excluded. For this reason it should be requested that also the relatively large standby exhaust air filters used for fresh air operation be designed so as to be redundant. This requirement is raised also with respect to the availability of the nuclear power plant.

Since filter systems operated discontinuously need an excitation signal to start operation, measurement of the radioiodine concentration in the exhaust air is a process requiring much attention. To the author, the technique employed in some plants of continuously monitoring only the noble gas concentration in the exhaust air is not sufficient to generate an excitation signal to start up the iodine filters, because the concentrations of noble gases and radioiodine in the exhaust air may show great relative variations. Major differences must be expected, for instance, between steam and water leakages of the coolant. For this reason, continuous iodine monitoring with alarm actuation should be provided for. Since the investment for continuous monitoring of low airborne activity concentrations of iodine besides noble gases is high, it should be seen whether one should not aim instead at continuous exhaust air filtration, that is to say, less sophistication for the measurement and more for the filtration.

Moreover, with a standby exhaust air filtration system the continuous release of unfiltered radioiodine must be assumed below the concentration limit which, when exceeded, actuates the exhaust air filters. Since there is no iodine filtration, also the elemental radioiodine, which can be removed relatively easily, is not removed from the exhaust air and may reach relatively large fractions of the total iodine in the exhaust air. For this reason, the author doubts that major easing for the release rates of fission product iodine, which is expected to result from an adequate consideration of the composition of the fission product iodine mixture in the air discharged (with respect to the importance of the pasture-cow-milk pathway), will really be applicable also for plants releasing mainly unfiltered exhaust air.

The recirculation air principle which is used, for instance, in all German pressurized water reactors allows the use of comparatively small filters with high removal efficiencies for the exhaust air of the plant compartments. In addition, recirculation air filters will be installed in plant compartments and operating compartments which are connected in a bypass to the recirculation coolers and in this way clean only part of the air stream to be cooled. The recirculation air filters of the operating room used for iodine removal may be employed also as exhaust air filters in certain ventilation concepts. Recirculation air filters are not required to reach the high removal efficiencies of exhaust air filters and for this reason can be designed less expensively. When they are occasionally used as exhaust air filters, for instance during refueling, this aspect ceases to be valid. Fig. 5 is a flowsheet of one of the most modern ventilation systems of German pressurized water reactors. The ventilation concept applied corresponds to the recirculation air principle.

4.2. Containment Concept and Requirements to Be Fulfilled by Standby Emergency Filter Systems for Cleanup of the Exhaust Air from the Annulus

The containment concept is of decisive importance in the

control of iodine releases as a result of accidents and for the requirements to be met by emergency filters. There is no other engineered safeguard, whether containment spray system, internal recirculation air filter, ice condenser or other pressure suppression systems with a decontaminating effect, which can so drastically reduce external radioactivity releases as the change from a single to a double containment. In a first approximation, it is of no importance whether the external containment is provided only by a sheet metal sealing barrier, the reactor building or a secondary containment made of concrete which acts as radiological shielding at the same time and offers good protection from external mechanical impacts. It is decisive in all these cases to ensure that the leakages of the primary, pressurized containment, depending upon the degree of mixing with the atmosphere in the annulus and the volumetric flow of the exhaust air from the annulus, will be diluted and delayed and can then be discharged through the exhaust stack usually after having been cleaned by an emergency filter system. The uncontrolled release of activity into the environment at low emission heights is prevented by a slight negative pressure in the annulus, annular rooms or reactor building. Through the external containment, therefore, only leakage from the environment into the annulus is possible.

The iodine filters used to clean the exhaust air from the space between the inner containment and the additional outer containment (annulus, for short) will be loaded only by the leak rate of the inner containment. This is very low if the sealing systems work satisfactorily, e.g., at levels $<0.25 \text{ \%}/\text{d}$ of the total volume of the inner containment. For this reason, the amounts of water and steam and the radionuclides which can reach the emergency filter units in the annulus are relatively small when compared with the single containment with direct filtration of the exhaust air.

Heating of the wall of the inner pressurized containment due to a loss-of-coolant accident heats the atmosphere in the annulus quickly. The relative humidity of the air, which can

easily reach 100 % during normal plant operation in an unheated and unvented annulus, will be reduced by the rising temperature within very short periods of time under the assumption that no major quantities of steam enter the annulus from the inner containment. This will generally be the case if the permissible leak rates are not exceeded. For this reason, the exhaust air filters of the annulus will be loaded only with low to medium radioactivities, and maximum temperatures in the range below 150° C will occur. In the decisive phase of filter operation the humidity of the air is below 100 % r.h. (increased pressure and increased temperature in the inner containment). Only when the temperatures of the inner containment and, hence, also of the annulus decrease, 100 % relative humidity of the air can be perhaps be reached again or even exceeded. This hazard may be met, for instance, by equipping the emergency iodine filter system with demisters and heaters.

The types of impregnated activated carbon now available are sufficient to control the conditions described above in the exhaust air of the annulus following a loss-of-coolant accident. However, it must be taken into account that studies in recent years have indicated the possibility of very rapid poisoning of the iodine filters as a result of the adsorption of filter pollutants. Therefore it is necessary, in the author's opinion, to build the emergency filter systems for the exhaust air of the annulus, which are needed to control the consequences of an accident, independent of the other exhaust air filter systems and to use them only under accident conditions. Otherwise it will not be possible to guarantee a satisfactory removal performance of the emergency iodine filters even when providing extra margins above and beyond the design quantity of activated carbon.

The demand for a special and separate emergency filter system, which must not be used while the plant is run in normal operation, has been fulfilled already in all German PWR nuclear power stations. Moreover, in this country the emergency iodine filters used on the exhaust air from the

annulus are only "gasketless" filters with large bed depths and long residence times, respectively, which attain the required removal efficiencies (in most cases 99.9 %) both for elemental iodine and for methyl iodide even at relative humidities of the air of 98 - 100 %.

In the author's opinion, the design of the emergency filter system for the annulus should cover also those operating conditions which may occur when there is an increased leakage of the inner containment above the assumed maximum level. Otherwise, if the permissible leak rate of the inner containment were exceeded, this would include the hazard of the second and last barrier protecting the environment of the reactor, namely the emergency exhaust air filter of the annulus, also failing at a crucial moment when it would be urgently needed because of the higher leakage. This might give rise to a chain of failures absolutely forbidden in other sections of the reactor safety philosophy. As a contribution to the discussion, the author proposes to use as a basis for designing the emergency filter system for the annulus the assumed maximum leak rate multiplied by a factor of five. Reference is also made to the higher volumetric flow rate which would have to be accommodated by the emergency filter system of the annulus as a result of the sudden expansion of the inner reactor containment following a loss-of-coolant accident.

While in earlier designs the relatively narrow annulus was not filled with plant components, modern nuclear power stations more and more have components installed in larger annular rooms which themselves can release water, steam and heat and, under incident conditions, even radioactivity. The emergency filter system for the annular rooms must be designed so as to take such impacts into account. This aspect may gain decisive importance when the whole reactor building constitutes the secondary containment.

The principle of double containment with the space in between the two containments being exvented through filter systems, above and beyond the decisive advantages mentioned

above, also offers a high degree of freedom in selecting the time at which the exhaust air filter systems of the inner containment should be used after accidents. Accordingly, events such as condensation, washout, sedimentation, collection on surfaces as a result of adsorption and chemisorption, and radioactive decay of shortlived radionuclides may become effective to reduce the airborne radioactivity and the water vapor and filter pollutant concentrations in the inner containment. In this way it is possible, even after major accidents, to wait for conditions which can be safely controlled with the components for the exhaust air filter systems presently available for the inner containment.

In the author's opinion, the necessary expenditure for suitable facilities in the inner containment should be made to prevent that a premature startup of exhaust air operation is enforced because of a lack of control of such events as pressure buildup, hydrogen generation, etc.

4.3. Requirements to Be Fulfilled by Iodine Filter Systems in Normal and Post-Accident Operation of Nuclear Power Stations

Fixing the operating conditions of and the requirements to be met by iodine filters must take into account the specific plant conditions, as is evident from Sections 4.1. and 4.2.. For this reason, only a few limit values and ranges can be referred to here which apply to a number of iodine filters in light water cooled nuclear power stations. The data in Table XI mainly apply to German nuclear power plants.

Typical accident conditions which must be controlled by the filter systems of American light water cooled reactors were indicated in the USAEC Regulatory Guide No. 1.52 (June 1973) (Table X), both for recirculation air filter systems in the containment (primary air cleanup systems) and for systems installed outside the containment and therefore subjected to less extreme conditions (secondary air cleanup systems). This includes, for instance, the exhaust air and

recirculation air filters for annuli and the control room and the emergency standby filter systems of boiling water reactors.

Table X: Typical accident conditions for atmosphere cleanup systems (from: USAEC Regulatory Guide 1.52)

Environmental conditions	Primary atmosphere cleanup system	Secondary atmosphere cleanup system
Pressure surge	result of initial blowdown	generally less than in a primary system
Maximum pressure	4 ata (60 psi)	approx. 1 ata
Maximum temperature of influent	136° C (280 °F)	81° C (180 °F)
Relative humidity of influent	100 % + condensing moisture	100 %
Average radiation level: airborne radioactive materials	10 ⁶ rads/hr a)	10 ⁵ rads/hr a)
For iodine buildup on adsorber	10 ⁹ rads a)	10 ⁹ rads a)
Average airborne iodine concentration for I ₂	10 ⁻¹ g/m ³	10 ⁻² g/m ³
For CH ₃ I and particulate iodine	10 ⁻² g/m ³	10 ⁻³ g/m ³
Required removal efficiencies b)		
I ₂	90 %	95 %; 99 % c)
CH ₃ I	30 %	95 %; 99 % c)

a) This value is based on the source term specified in Regulatory Guide 1.3 or 1.4, as applicable.

b) The removal efficiencies to be proved for sorption material in laboratory experiments are higher (see Table XIII).

c) At a maximum relative humidity of the air of 70%; removal efficiencies of 95 % refer to 2" depth of bed, those of 99 % to depths of bed \geq 4".

Table XI: Typical operating conditions and requirements to be met by iodine filters under normal operating conditions and accident conditions

Environmental operating conditions and requirements	Filter systems for normal operation	Filter systems for accidents (emergency filters for the exhaust air from the annulus or exhaust air filters from the inner containment)
<u>Filter supply air</u> Temperature Humidity of the air Condensate generation Pressure Fission product iodine concentration <u>Loading of ^{131}I</u>	$< 80\text{ }^{\circ}\text{C}$ frequently $\leq 50\text{ }^{\circ}\text{C}$ $\leq 100\%$ r.h. frequently $\leq 70\%$ r.h. yes, in specific cases; small quantities 1 ata $< 10^{-8}\text{ g/m}^3$ $< 10^{-2}\text{ Ci }^{131}\text{I/h}$	$\leq 120\text{ }^{\circ}\text{C}$ $\leq 100\%$ r.h. yes, occasionally, large quantities +) occasionally > 1 ata possible $< 10^{-2}\text{ g/m}^3$ $< 10^5\text{ Ci }^{131}\text{I}$ on the whole
<u>Required removal efficiencies</u> I_2 ^{131}I as $\text{CH}_3^{131}\text{I}$	99 - 99.9 % 90 - 99.9 %	99 - 99.9 % 90 - 99.9 %

+) Approximately 10 - 100 kg of condensate can be produced in the activated carbon of an iodine filter because the temperature drops below the dew point in the initial phase of filter operation.

A comparison of the conditions of emergency filter systems outside the containment (secondary atmosphere cleanup systems and filters for annulus or inner containment exhaust air) given in Tables X and XI shows similar values if one starts on the upper iodine release level limits in Table XI.

The high removal efficiencies required in Table XI are achieved in the Federal Republic of Germany by the use of deep bed filters (depth of bed up to 60 cm).

The assumptions about the radioactivity concentration in the inner containment vary over a broad range because of the different technical designs of reactors and the resultant accident assumptions. In USAEC Regulatory Guides 1.3 and 1.4, a release of 25 % of the equilibrium iodine activity of the reactor core at full power is assumed in a loss-of-coolant accident. The calculation assumes that this radioactivity is available immediately for a leakage of the inner containment. This value probably constitutes an upper limit of the releases assumed. Since the effect of systems reducing the radioactivity, such as spray systems and recirculation air filters, can be assessed in very different ways, even the most adverse assumptions underlying the release of fission product iodine from the reactor core will still allow a wide range of actual loading of the emergency filters, which also includes low activity levels. Because of the difficulty to proof, for instance, the removal efficiency of spray systems is not taken into account in the Federal Republic of Germany in calculating the iodine concentration in the containment.

Different assumptions have been made in various countries about the physical and chemical composition of the fission product iodine mixture in the containment following a loss-of-coolant accident. In the United States, a mixture consisting of 91 % I_2 , 4 % CH_3I , and 5 % particulate iodine is assumed (487), while in the Federal Republic of Germany 85 % I_2 , 10 % CH_3I and 5 % particulate iodine is assumed. Because of the uncertainties still existing with respect to the reaction and removal behavior of fission iodine in the

post-accident atmosphere of the containment and also the annulus, and because of the concentration of iodine, water vapor and organic compounds, which will vary over an extremely broad range, the author thinks it appropriate to use for the total removal efficiency relative to fission product iodine of emergency filters no higher value than that which can be assumed for the fraction occurring as methyl iodide.

One particular difficulty associated with the use of filters in accident situations is due to the possibility of the temperature falling below the dew point. Since, as a rule, emergency filters will be at room temperature before being used, the temperature in the filter and in the iodine sorption material, respectively, may well be below the dew point for a start-up phase, even if droplet separators and preheaters are used, because the dew point temperature of the incoming air - steam mixture is above the temperature of the filter.

In the footnote on Table XI, limit values were indicated for the amount of condensate produced in the activated carbon of a filter at room temperature which had been calculated for some iodine filters under post-accident conditions for a sudden generation of air - steam mixtures of higher temperatures. So far, only insufficient experimental data are available to allow an estimate to be made of the effect of the transient condensate production upon the removal efficiency. Accordingly, this point is still associated with major uncertainties.

Iodine filters in gas cooled reactors are subject to conditions which deviate greatly from those mentioned in Tables IX and X. Because of the very different types of gas cooled reactors it is not possible to give any general information here. Data pertaining to iodine filters in Magnox reactors, for instance, are 24 bar of CO₂ and 250° C, for AGR's 50 bar of CO₂ and 200° C 497 and for HTR's He and temperatures up to 600° C 507.

5. Design of Iodine Filter Systems

5.1 Individual Elements and Their Arrangements

Iodine filters must be able to remove both particulate and gaseous iodine from the gas stream to be cleaned. The removal efficiency relative to particles of the iodine sorption filter is low. The requirement mentioned above therefore makes it necessary to have a design consisting of at least one aerosol filter and one iodine sorption filter. Since iodine adsorbed onto particles can be desorbed again and since particulate iodine, such as the metal iodides, may be transformed into elemental iodine by means of an oxidation process and, hence, be changed into the gaseous form, this aerosol filter must be installed upstream of the iodine sorption filter. In order to ensure sufficiently high removal efficiencies, a high efficiency particulate filter (class S aerosol filter, HEPA filter) should be used at this point.

Another purpose of this aerosol filter is the protection of the downstream iodine sorption filter from dust accumulation which could give rise to plugging and to a loss of removal efficiency.

Abrasion of the sorption material produces dust in the iodine sorption filter. This applies in particular to the filling process. The dust may become contaminated by radioactive iodine and may be removed with the filter exhaust air. For maximum overall removal efficiency the iodine sorption filter should therefore be followed by another aerosol filter. Since the relatively large carbon dust particles are easily removed, a simpler filter will do at this point. However, in most filter systems a HEPA filter is found also at this point.

In order to extend the service life of HEPA filters (in Germany, class S aerosol filters), simple prefilters may be used for dust removal. An iodine filter therefore may consist of the following filter stages: prefilter and HEPA filter to remove aerosols, iodine sorption filter to remove gaseous iodine, and an aerosol filter to remove dust from the iodine sorption filter.

If extremely high relative humidities of the air must be expected in the influent of filters, systems should be installed for reduction. In the simplest case this can be a heater. Heating by only 10° C will already reduce the relative humidity of the air from 100 % to ≤ 70 % in the temperature range below 100° C. This will greatly reduce the amount of water adsorbed in the iodine sorption material. It should be indicated that the removal efficiency of aerosol filters can sharply drop as soon as approximately 85 % r.h. is exceeded.

If condensation cannot safely be excluded in the atmosphere to be filtered, a moisture separator and mist eliminator should be installed upstream of the heater. In this installation it should be taken into account that the removal efficiency of most demisters drops sharply below a specific drop size limit, which is a function mainly of the type of demister and the face velocity of the gas.

If a temperature drop below the dew point and, hence, condensation in the filter must be safely prevented even during start-ups, or if very large quantities of steam are produced, the filter influent may be passed through a condenser which should be followed by a demister and a heater. Such systems are installed, for instance, in the gland seal suction systems in which the amount of steam released by leaks may by far exceed the amount of air leaking in at the same time. The condensation process in this case greatly reduces the volumetric flow rate of the filter influent.

Additional pre-cleaning steps should be envisaged in the presence of highly corrosive components in the filter influent. For instance, to clean the exhaust air from the containment of a sodium cooled reactor, sand bed filters are installed upstream of the HEPA filters, because the glass fibers usually making up the fiber mat of the HEPA filters are attacked by sodium aerosols and their reaction products.

In principle, all filter components should be installed upstream (on the negative pressure side) of the fan of the

atmosphere cleanup system in order to safely prevent contamination of the area of installation by leakages.

5.2. Redundancy Requirements

Iodine filter systems for continuous filtration of the exhaust air during normal operation are mostly equipped with two complete filter trains so that exhaust air operation can be maintained also while the filters are being replaced. Also most emergency standby gas treatment systems are equipped with two filter trains. The redundancy of the fans for emergency air cleaning systems is $2 \times 100 \%$. In order to have some redundancy left also during repair work on one fan, an installation providing for $4 \times 50 \%$ should be preferred.

On account of the low probability of occurrence of major accidents, redundancy is frequently required only for the fans in the emergency exhaust air cleaning systems for the annulus or the annular rooms. This design should be discussed anew in the light of more recent findings about the effects of different air pollutions and their role as filter poisons. Because of the increased temperatures occurring in the area of the annulus in major reactor accidents, an increased release of solvents from paints and plastics and of vapors from lubricant films etc., perhaps even the occurrence of combustible products, must be taken into account. The iodine sorption filters are loaded with the compounds released and, as is known from experience in filter operation, may rapidly lose removal efficiency.

Moreover, even if the low design leakage of the inner containment is preserved, a considerable radiation exposure of the annulus due to the hard γ -radiation of the radio-nuclides released in the inner containment must be envisaged which could give rise to radiation induced chemical reactions and the respective reaction products in the annulus. Reference should also be made again to the possibility of major steam leaks from the plant components in the annular rooms. In the author's opinion, therefore, a redundant design also of the emergency exhaust air filters for the annular rooms should be required. Measures allowing the

replacement of filters and sorption materials after accidents should be discussed. In order to be able to take a filter train out of exhaust air operation after it has been poisoned or in the case of iodine desorption, there must be facilities for removal of the decay heat of the trapped radionuclides. A relatively simple solution is the change-over from once-through exhaust air operation to the recirculation mode.

5.3. Design and Structure of Iodine Sorption Filters

In principle, two types of activated carbon filters must be distinguished: the "gasketless" deep bed vessel type filters and the cell type filters. Fig. 2 is a drawing of a deep bed vessel type filter with horizontal gas flow, Fig. 6 and 7 show filter cells.

Deep bed vessel type filters in principle consist of a casing (vessel) whose upstream and downstream sides are made of wire mesh and perforated metal screens with round or slotted holes. Vessel type filters are permanently installed in the exhaust gas duct and filled with the iodine sorption material. For this reason, vessel type filters include systems which allow the iodine sorption material to be filled and discharged in situ, and upstream and downstream exhaust duct connections. A typical characteristic of vessel type filters is the possibility of accommodating large amounts of activated charcoal in a simple geometric arrangement which, compared with cell type filters, provides larger depths of bed and, hence, also higher pressure drops (usually < 300 mm of water at design flow).

In vessel type filters, the need to use seals or gaskets to separate the upstream from the downstream sides can be eliminated completely by proper design measures. Cell type filters for fission product iodine sorption are designed for complete exchange, including the case and the sorption material. The filter cells are clamped against a mounting frame equipped with sealing faces or sealing lips. The filter cell is sealed relative to the mounting frame by means of a face seal or gasket. The filter cells may be

arranged in individual filter housings, in a multiple single-filter array, or in banks in a single filter housing. A filter cell of the international standard dimensions of 610 x 610 x 292 mm contains a maximum of some 70 l of iodine sorption material. The bed depth is usually between 2.5 and 5.0 cm. The sorption material can be arranged in the filter cell in flat, parallel or V-shaped layers (Fig. 6, pleated bed cells) or may be used in annular layers in cartridges which are screwed into the filter cells (Fig. 7). Usually, the pressure drop of activated carbon filter cells at design flow rates is small (< 40 mm of water). There are only very few filter cell designs which can be re-used after replacement of the activated charcoal and the gaskets.

Out of the multitude of other filter designs the wall type filter directly loaded with iodine sorption material (Fig. 8) should be mentioned, which can offer the advantages of vessel type filters while requiring relatively little space, which means that it can be used preferably where large volume flows must be filtered [51, 52].

In principle, care should be taken in the design of iodine sorption filter systems, wherever possible, to have vertical air flow only in the downstream direction or horizontal air flow. The number of gaskets and seals and the lengths of sealing areas should be minimized. Unavoidable sealing areas should be covered, if possible, by a layer of sorption material. Bolts, screws etc. penetrating the layer of iodine sorption material in the flow direction should be avoided. Subsequent sagging of the sorption material must not result in leakages. A uniform air velocity of the air must be ensured over the entire exposure area of the filter. In the design, construction and choice of materials such effects as temperature, ionizing radiation, corrosive media, humidity and, occasionally, the occurrence of vibrations, pressures and pressure shocks must be taken into account. When selecting gaskets and sealing elements, in particular their aging and radiation resistance must be checked. There must be facilities for sampling the iodine sorption material,

leak testing the filters and indication of the differential pressure over the layer of sorption material.

The iodine sorption filters should show the name of the manufacturer, the dates of fabrication (impregnation) of the iodine sorption material and of filling of the filter unit, the penetration of radioactive iodine as methyl iodide and elemental iodine and, in addition, the maximum permissible levels of volumetric flow rate, temperature, differential pressure and relative humidity of the gas. Vessel type filters should indicate the permissible grain size fraction of the iodine sorption material.

Presently, iodine sorption filters used to clean the exhaust air and recirculation air of nuclear power stations almost exclusively employ impregnated activated carbon. Only in special cases, such as coolant gas cleaning or recirculation and exhaust air filtration of the reactor building of gas cooled reactors, inorganic silver or silver nitrate bearing iodine sorption materials are used because of the high temperature requirements.

The removal efficiency of an iodine filter relative to a specific iodine compound can be indicated by the decontamination factor DF:

$$DF = \frac{c_0}{c} ; \quad (1)$$

where c_0 = concentration of the iodine compound in the filter influent

c = concentration of the iodine compound in the filter effluent.

The removal performance is frequently expressed in terms of the removal efficiency η , which can be calculated from the decontamination factor in accordance with (2). The removal efficiency is usually indicated in %.

$$\eta = \left(1 - \frac{1}{DF}\right) \cdot 100; \quad \text{[\%]} \quad (2)$$

Frequently, the penetration D of a filter is indicated instead of the decontamination factor and the removal

efficiency. D can be calculated from η according to (3):

$$D = 100 - \eta ; \quad \text{(\%)} \quad (3)$$

The reduction in the concentration of gaseous elemental iodine, methyl iodide and various other iodine compounds in the sorption material bed of an iodine filter can be expressed in a first approximation under the assumption of irreversible adsorption and chemisorption, respectively, by a simple exponential equation of the form of

$$c = c_0 \cdot e^{-K''x} ; \quad (4)$$

where x = depth of the iodine sorption bed
 K'' = constant.

If the linear gas velocity of the gas mixture to be filtered is constant, a specific bed depth x of the iodine sorption material corresponds to a certain residence time t of the gas mixture in the iodine sorption bed.

$$t = \frac{V}{\dot{v}} ; \quad (5)$$

where V = bulk volume of the iodine sorption material

\dot{v} = volumetric flow rate of the gas mixture to be filtered.

For the practical application of (4) it is useful to substitute the corresponding residence time t for the bed depth x . In this way, (5) and (6) is obtained as

$$c = c_0 \cdot e^{-K't} ; \quad (5)$$

$$\frac{c_0}{c} = e^{K't} = DF ;$$

$$\frac{\log DF}{t} = K \quad (6)$$

K is a constant (K -factor or performance index) which is a function of the iodine compound to be removed, of the type,

batch and condition of the respective iodine sorption material, and the removal conditions such as velocity, relative humidity and temperature of the gas mixture to be filtered. t is usually indicated in seconds. Equation (6) can be used to calculate the residence time and bed depth, respectively, necessary to achieve a specific decontamination factor.

The functions describing the dependence of K on the different parameters cannot yet be taken from the literature. One basic difficulty consists in the fact that the different batches of the same type of iodine sorption material made by the same manufacturer may turn out to perform very differently and therefore make it impossible, even if the most important parameters are fixed, to indicate a binding K - factor without experimental tests of the respective batch of iodine sorption material. This is true in particular of activated carbon.

With respect to the pronounced variations in removal conditions frequently found in practical filter operation and the large number of parameters influencing K , it seems to be necessary, at first sight, to determine K -factors for a multitude of combinations of the different parameters. However, the number of measurements can be reduced to a very large extent.

Usually, an iodine filter is designed for certain decontamination factors for elemental iodine and methyl iodide. Since, as a rule, iodine present as methyl iodide is removed at least two orders of magnitude less efficiently than elemental iodine, and since the fraction of methyl iodide and other iodine compounds of a similar removal behavior may dominate in the filter influent, it is useful, in order to achieve a satisfactory degree of safety, to design iodine filters for the removal of methyl iodide under the most adverse operating conditions. These are characterized, above all, by the maximum attainable relative humidity of the influent and the amount of water adsorbed in the iodine sorption material in equilibrium with that humidity, at the lowest temperature of the filter influent to be expected (low reaction rate) and maximum loading with methyl

iodide.

If higher temperatures are reached in the filter influent, an additional removal and desorption test is necessary at the maximum relative gas humidity possible in that case.

Since minor differences in the face velocity of the gas at the same residence time have only a minor influence on the removal efficiency, the decontamination factors determined for a certain residence time may be used also for iodine sorption beds of slightly different depths, but with the same bulk volume of carbon.

The results of removal efficiency tests with higher methyl iodide loadings may be regarded as conservative with respect to the removal at lower loadings.

In the author's opinion, a broad range of filter operating conditions can be covered safely enough without additional tests, if the K-factors of the iodine sorption material encountered are known at 70 and 98 - 100 % r.h., approximately 30° C, a face velocity of the gas of approximately 25 cm/s, and a methyl iodide loading of approximately 100 μ g per g of sorption material. The Euratom intercomparison tests presently carried out to test iodine sorption material already supply a valuable set of data (valuable, because they are measured by different laboratories under identical conditions). For the iodine sorption materials mainly used in the Euratom area the range of variation in K-factors should be determined under the conditions mentioned above and minimum values should be indicated below which the level should not drop even in the light of unavoidable fluctuations in the fabrication process. Only in this way will manufacturers of iodine filters be able to arrive at safe designs.

Below, a number of guidelines and guide values recommended by the author for the design of iodine sorption filters in nuclear power stations will be repeated whose application is intended to result in most reliable iodine sorption filters at reasonable technical expenditure:

Removal Efficiency

Iodine sorption filters for exhaust air cleaning must be designed for removal efficiencies of at least 99 % relative to radioiodine as methyl iodide. Recirculation air filters should achieve a removal efficiency of at least 95 % relative to radioiodine as methyl iodide.

Loading Capacity

With respect to the loading capacity of iodine sorption filters, a gaseous fission product iodine mixture consisting of 90 % elemental iodine and 10 % methyl iodide should be used as a basis for light water cooled reactors. For gas cooled reactors, 100 % methyl iodide must be assumed.

When using KI-impregnated activated carbon, loadings in excess of 0.1 mg of methyl iodide and 1 mg of elemental iodine per gram of carbon should be avoided.

If other impregnating agents and sorption materials are used, or if the residence times are very long, these levels may be exceeded, but sufficient loading capacity must then be proved by removal efficiency tests.

Relative Humidity of the Incoming Air

If no higher levels are to be expected, the design of iodine sorption filters should be based on 70 % relative humidity of the incoming air. In principle, it must be assumed that the iodine sorption material is in an adsorption-desorption equilibrium with a content of water vapor in the filter influent which corresponds to the maximum possible relative humidity. The effect of systems installed to reduce the relative and absolute humidities, respectively, of the influent (e.g., heaters, coolers followed by downstream demisters and heaters) should be taken into account in fixing the maximum level of relative humidity of the influent. In this case, 10 % should be added to the maximum relative humidity of the influent set by these systems.

Temperature Drop below the Dew Point and Condensation

Inside the filter train a temperature drop of the incoming air below the dew point should be avoided. At least the generation of condensate should be limited to an extent which ensures that a permissible amount of water loaded to the sorption material is not exceeded. The permissible amount of water should be tested experimentally.

Operating Temperature

Without additional tests, (proof of desorption and ignition behavior) impregnated activated carbon should be used only at temperatures up to a maximum of 120° C. However, inorganic-base iodine sorption materials may be used at higher temperatures. These upper temperature levels must be fixed separately for each material.

Combination of Humidity of the Air and Operating Temperature

An adverse factor with respect to the removal efficiency of iodine sorption materials relative to methyl iodide is the combination of maximum relative humidity of the air and the lowest operating temperature. The required amount of sorption material and the residence time, respectively, must be determined with these conditions in mind.

Bed Depth

For emergency filters a bed depth of the iodine sorption material of at least 20 cm must be provided. This applies also if the desired removal efficiency could be achieved with a lower bed depth.

Air Velocity

Face velocities of the air between 25 and 50 cm/s are recommended for iodine sorption filters.

Aging Margin

The aging margin should be at least two thirds of the "design quantity" of iodine sorption material. In testing the fresh iodine sorption material with radioactively labeled methyl iodide the required overall removal efficiency of the iodine

sorption filter must be achieved with a bed depth corresponding to the design quantity. Tests of the used iodine sorption material (from control filters or the original filters) will always be carried out at a bed depth which corresponds to the actual bed depth of the respective iodine sorption filter.

Removal Efficiency of Impregnated Activated Carbon

In the fresh condition the impregnated activated carbon used in iodine sorption filters should attain a K-factor of at least 5 in a test with radioactive methyl iodide at 98 - 100 % relative humidity of the air, 30° C and the anticipated face velocity of the air. For different iodine sorption materials, the test conditions and the minimum value of the K-factor must be fixed under conditions required by the use of the respective iodine sorption material.

In concluding this chapter, reference is made to a manual on the design, construction and testing of nuclear filter systems [537], from which a multitude of data can be taken, especially for systems with filter cells (adsorber cells).

The status of the design and construction of nuclear filter systems has been critically reviewed elsewhere [547]. A brief survey will be made here of the faulty design examples referred to in that report and elsewhere. However, this list cannot claim to be complete:

- Faulty design of filter casings as a result of less stringent requirements imposed upon systems in conventional air conditioning and ventilation technologies. This may give rise to insufficient mechanical stability and to major leakages.
- Use of structural materials of low thermal and mechanical stability and insufficient resistance to radiation.
- Sealing of sealing edges and areas with caulking compounds, mastic or paint. Spot welded metal sheet constructions are frequently sealed only by paint.

Because of insufficient mechanical properties shorter service life must be expected; this type of sealing offers but little resistance to temperature and radiation.

- Insufficient clamping devices for filter cells. Up to 4 filter cells in one filter wall are clamped by the same corner bolt. There is no individual compression for the gasket of each filter cell, which is urgently recommended.
- No sufficient gasket compression can be exerted on the face gasket of the filter cell. Minor irregularities in the gasket and the mounting frame cannot be equalized and will result in leakages.
- Filter cell is clamped by an insufficient number of unevenly distributed bolts.
- Clamping device is too weak for heavy iodine sorption filter cells.
- Filter cells are positioned too close side by side. Installation and removal is greatly aggravated.
- Insufficient space above and below deep bed filters of the vessel type for easy and contamination-free replacement of the iodine sorption material.
- HEPA filters upstream of the iodine sorption filter are missing.
- Ports for injecting and removing test agents are missing or installed in the wrong places.
- Filter systems constructed so compact that a uniform distribution of the test agent in the influent and effluent air cannot be achieved.
- No possibility of taking representative samples of the iodine sorption material.
- The upstream and downstream sides of filters are interconnected by drainage lines which cannot be closed.

This may cause leakages.

- Pan drains for the water removed by moisture separators or filters are too small; insufficient number of drainage lines.
- No moisture separators are provided, although major underrunning of dew point temperature in filter influent is anticipated.
- Air flow across the area of the filters is non-uniform.
- Doors of filter chamber are not large enough; compression force of door insufficient.
- Absence of double pin or slip pin hinges which would allow satisfactory compression force of the door to be achieved.
- Insufficient number of door locks; no uniform compression force provided.
- Doors cannot simply be locked, only bolted. This complicates inspection and replacement of filters.
- Door gaskets are too hard for sealing purposes and are not made of closed-cell neoprene sponge.
- Door gaskets are not molded in one piece. This may cause leakages, especially in the corners.
- Illumination levels in man-entry filter housings are insufficient.
- Electrical conduits and other lines penetrate through filter walls.
- Leaks exist between the upstream and downstream sides of filters as a result of unsealed bolts, screws, etc.
- Use of ventilation ducts bent at right angles. This gives rise to unnecessarily high pressure drops.

- No vibration isolation between fan and floor.
- No flexible connection between fan and ventilation duct.
- Elastomer connections installed so close to the filter that an excessive radiation dose may be reached.
- Connecting lines to instruments are made of materials with insufficient resistance to temperature and radiation, such as a number of plastics.
- No measurement of differential pressure or other instrumentation.
- Insufficient space; systems impede replacement and testing of filters.
- No physical separation and shielding between redundant filter units to control emergency conditions.
- Filter cells and iodine sorption material insufficiently packed; rendered useless on transport and storage.
- Insufficient information on filter casings.

6. Surveillance of Iodine Filter Systems

6.1. Testing the Iodine Sorption Material

6.1.1. Scope of Test

As has been demonstrated in previous chapters, the removal efficiency of iodine sorption filters is a function of the design, the operating conditions, the quality and the actual condition of the iodine sorption material. In addition to a small number of inorganic iodine sorption materials there is a broad range of types of impregnated activated carbon. The market is supplied with different types of impregnated activated carbon of different removal efficiencies by a number of manufacturers.

In principle, the removal efficiency of each of the different types of activated carbon must be proved by suitable tests. However, since different batches of impregnated activated carbon of the same type made by the same manufacturer may greatly vary in removal efficiency [557], there is the additional need to test each individual production batch. In addition, it should be known whether, after some storage time, a specific batch tested still has the removal efficiency measured on the fresh material, or what change it has undergone meanwhile. Data published in the literature indicate that the removal efficiency may decrease as the storage time increases, even when the product is stored in plastic bags sealed airtight. Under these conditions, for instance, a decrease of removal efficiency within 33 months from 99.85 to 99.12 % was measured in a test of activated carbon samples with radioactively labeled methyl iodide at 98 - 100 % r.h. [557].

L.R. Taylor and R. Taylor studied steady state aging of both plain and impregnated batches of activated carbon and found that the most important contribution to aging is made by processes occurring in the activated carbon, while the contribution by changes in impregnation is considered to be

relatively slight /567. One potential cause of steady state aging of activated carbon is said to be the migration of sulfur within the carbon to the active centers of the surface.

On the whole, steady state aging is a relatively slow process. When activated carbon is stored in dry rooms at room temperature and in an airtight enclosure, a storage time of approximately up to 1 year is not likely to require another test of the removal efficiency of that activated carbon, according to the author's experience.

In iodine filters, the iodine sorption material is exposed to a number of additional influences while in use, which also reduce the removal efficiency. This subject will be dealt with in more detail in the next chapter. The effect of this dynamic type of aging may be much more serious than that of steady state aging and may very quickly result in major losses of removal efficiency and, hence, in a decrease below the minimum removal efficiency to be attained by the respective iodine filter.

In the light of these findings there is an obvious need to test samples of the original batches of iodine sorption material used in iodine filters -

- (1) before the use in iodine filters (random sample of production batch);
- (2) before the use, after prolonged storage time following the test, of iodine sorption material already tested (random sample of the quantity stored);
- (3) at regular intervals over the period of operation of iodine filters (representative samples of the iodine sorption material right from the filter or samples exposed in the bypass under the same conditions).

6.1.2. Test Agents and Equipment

In practically all laboratories working on this aspect, iodine sorption materials are presently tested for their

removal efficiencies with radioactively labeled methyl iodide as the test agent. Methyl iodide is regarded also as a model substance for other organic iodine compounds. In a few specific cases radioactively labeled elemental iodine is used. The use of gaseous hypoiodous acid as the test agent so far has been limited to a very few tests and, because of the uncertainties with respect to the significance of this compound and the difficulties associated with its preparation, will hardly ever be applied on a broader basis. The techniques of preparing radioactively labeled methyl iodide and iodine are described in Section I of the Annex.

Various laboratories use test equipment to determine the removal efficiencies of iodine sorption materials relative to radioactively labeled methyl iodide or elemental iodine which may differ greatly in design and equipment, but always allows tests to be carried out at high humidities of the air or gas and at different flow rates. The parameter most difficult to set and to measure is the relative humidity of the carrier gas. This is true in particular when measurements must be carried out in the range of high relative humidities of the air ($\geq 95\%$ r.h.). Intercomparison tests performed through Euratom nevertheless showed a rather satisfactory agreement among the results measured by the participating laboratories.

Descriptions of the test equipment used by the different laboratories may be taken from the Proceedings of the Euratom Seminar on Iodine Filter Testing, volume I, document V/559/74 (March 1974). The intercomparison tests carried out so far do not indicate any special superiority of a specific method or arrangement. A test apparatus developed at the author's laboratory, which allows a relatively large variation of the test conditions, will be described in Section II of the Annex.

6.1.3. Establishing the Test Conditions of Iodine Sorption Materials

The test conditions are a function of the anticipated operating conditions of the iodine sorption material in the filter unit. Accordingly, tests must be carried out under the simulated most adverse operating conditions of the respective iodine sorption filter. Moreover, standard tests are needed to compare the removal efficiencies of different batches and types of iodine sorption materials.

The most adverse conditions for iodine removal by solid iodine sorption materials are represented by a combination of

- (1) maximum flow rate of the carrier gas, that is, minimum residence time;
- (2) maximum water loading (adsorption, condensation) of the iodine sorption material before the exposure to fission product iodine;
- (3) maximum relative humidity of the atmosphere to be filtered;
- (4) maximum pressure of the atmosphere;
- (5) maximum loading with large quantities of fission product iodine species as methyl iodide;
- (6) maximum loading with fission product iodine radioactivity;
- (7) maximum dose rate and, as a consequence, radiation dose including external radiation;
- (8) maximum service time;
- (9) maximum pre-loading with filter pollutants.

With respect to the removal behavior, measurements carried out by the author have shown that the

- (10) lowest operating temperature (in the range between room temperature and approximately 100° C)

must be regarded as the most adverse temperature.

As far as the desorption behavior of iodine already trapped is concerned, the

- (11) maximum operating temperature (with impregnated activated carbon, this is significant above approximately 120° C)

must be regarded as the critical condition.

The conditions referred to under (1) - (5) and (9) and (10), respectively, may be realized within broad ranges in the batch tests of iodine sorption materials.

The conditions listed under (6) and (7) can be established only at extreme expenditure, especially in measurements of emergency filters. The (high) radioactivity loading mentioned under (6) influences the removal mainly by the increase in temperature in the iodine sorption material and, to a lesser extent, the radiation induced desorption due to the formation of compounds of iodine already trapped. As a consequence, the effect of the radioactivity loading can be simulated in part by taking into account the maximum possible increase in temperature in the iodine sorption material. Moreover, if the fraction of impregnating agent was sufficiently high (several percent), no major direct influence of high radioactivity loads upon the removal efficiency was observed, even in iodine impregnated activated carbon removing radioactive iodine by means of isotope exchange reactions [25, 347].

The removal efficiency of iodine sorption materials under external radiation of very high dose rates ($> 10^6$ rad/h) can be tested only in expensive irradiation facilities and test rigs. Again, the effect is due to the increase in temperature and the formation of compounds with subsequent desorption of iodine already removed. In the author's opinion, one qualification test should be carried out for each specific type of iodine sorption material on an average batch. The dose rate, the dose and the humidity of the

carrier gas should be so high that all the conditions to be expected in practice are anticipated.

The maximum period of operation referred to under (8) cannot be simulated in the batch tests. However, it depends to a large extent on the maximum attainable pre-loading with pollutants listed under (9). Again, a qualification test should be discussed, on the basis of which a sufficient aging margin is added to the required minimum quantity (design quantity) of iodine sorption material. This point is referred to in more detail in Section 7.2.

In the author's opinion, the desorption behavior at elevated temperatures ($> 120^{\circ}$ C) mentioned under (10) should also be investigated by a qualification test.

Summing up, the batch test for each production batch of iodine sorption material should be carried out with a material preconditioned with respect to the adsorption of water vapor, a maximum relative humidity of the gas, maximum loading with radioactively labeled methyl iodide, and at a mean carrier gas velocity to be expected.

The carrier gas pressure needs to be taken into account specially only if there are major deviations from atmospheric pressure. The test temperature recommended by the author is room temperature, unless temperatures $> 100^{\circ}$ C must be expected. The radioactivity level of the test agent is best determined in the light of the detection sensitivity of the separation factor anticipated. The duration of the experiment is a function of the time required for pre-conditioning, loading and sweeping. As a rule, it will not exceed 24 hours in a batch test.

In addition to these removal tests carried out under partly simulated operating conditions of iodine sorption filters, standard tests are felt to be necessary under test conditions uniformly agreed upon which, on the one hand, will allow a comparison to be made of the capabilities of different iodine sorption materials and batches and, on the other hand, will also conservatively cover operating

conditions expected to occur frequently. This aspect was taken into account in the preliminary establishment of the conditions for the Euratom intercomparison tests. Moreover, the permissible variations of the test parameters were narrowed down so much that, on the one hand, as many laboratories as possible can participate with the test equipment available to them and, on the other hand, comparable test results can be expected. Some of the conditions presently observed in these intercomparison tests are shown in Table XII.

Each test of an activated carbon batch should record the following data, in addition to the test conditions listed in Table XII: type, number of production batch, grain size distribution, fabrication date (time of impregnation of the activated carbon), type and quantity of the impregnating agent, water content of the activated carbon as supplied (in percent of the dry weight of the activated carbon), water uptake during the test, differential pressure over the activated carbon test bed.

Table XIII lists the removal efficiencies and conditions achieved and set, respectively, in laboratory tests of activated carbon batches according to USAEC Regulatory Guide 1.52 (June 1973).

No exact comparison can be made with the requirements imposed upon the removal efficiency of activated carbon in other countries, because the removal efficiencies specified are not explicitly tied to specific residence times, and no information can be given about the face velocity of the incoming air stream. If the stay time recommended in Regulatory Guide 1.52 of 0.25 s per 5.1 cm of bed depth is used as a basis (corresponding to a linear velocity of the air of 20.3 cm/s), the K-factors indicated in brackets can be calculated. High performance types of impregnated activated carbon have K-factors > 10 at 95 % r.h., a grain size fraction of 8 - 14 mesh (Tyler) and a linear air velocity of 25 cm/s.

Table XII: Preliminary test conditions in the Euratom intercomparison tests of the removal efficiencies of activated carbon

Activated Carbon Test Bed

Volume of activated carbon: $> 25 \text{ cm}^3$; bed depth: 5 - 20 cm
(in individual beds, if possible, of 5 cm depth);

Test bed diameter: 1.8 - 5.0 cm ¹⁾.

Test Agent

Chemical form: mixture of $\text{CH}_3^{127}\text{I}$ and $\text{CH}_3^{131}\text{I}$;

Radioactivity concentration in the carrier gas: as required (determined by the sensitivity of detection desired);

Mass concentration in carrier gas: depending on desired loading, volumetric flow rate and loading time;

Loading of the activated carbon with the test agent:
approximately 50 - 100 $\mu\text{g/g}$.

Carrier Gas for Test Agent

Wet air, prefiltered by class S aerosol filter (HEPA filter);

Relative humidity of gas: 95 % and 98 - 100 %, respectively;

Temperature (at the same time temperature of test bed):
room temperature up to a maximum of 30°C ; temperature must be kept constant for the duration of the experiment;

Residence time in test bed: $\geq 0.2 \text{ s}$;

Face velocity of air: approximately 25 cm/s.

Duration of Test

Pre-humidification of the activated carbon by sweeping with wet air (conditioning): $\geq 16 \text{ h}$.

Loading with test agent: 10 - 60 min;

Subsequent sweeping with carrier gas containing no test agent: 1 - 2 h.

1) To avoid excessive channeling around the test bed, the diameter of the test bed should at least be 12 times the largest grain diameter.

Table XIII: Laboratory test requirements for activated carbon for fission product iodine removal (quoted from USAEC Regulatory Guide 1.52, June 1973)

Activated carbon, bed depth [cm]	Iodine filter used in	Removal efficiency assigned [%]	Laboratory test requirements for a representative sample
5.1	Recirculating air filtration system in primary containment	I ₂ : 90 CH ₃ I +) : 30	Test initially, and yearly thereafter, under 95 % relative humidity, maximum design temperature and design face velocity for an elemental iodine penetration of < 1 % and < 10 % for methyl iodide, (K ≥ 4) ⁺⁺).
5.1	Air filtration system outside of primary containment, r.h. ≤ 70 %	I ₂ : 95 CH ₃ I +) : 95	Test with methyl iodide ⁺ initially, and yearly thereafter, under 70 % relative humidity, maximum design temperature and design face velocity for a penetration of < 1 %, (K ≥ 8) ⁺⁺).
10.2 15.2 20.3 38.1	" " " " } }	I ₂ : 99 CH ₃ I +) : 99	Test with methyl iodide in 2 inch (5.1 cm) increments initially and semi-annually thereafter for the 4 inch (10.2 cm) bed, every eight months for the 6 inch (15.2 cm) bed, and annually for the 8 inch (20.3 cm) and 15 inch (38.1 cm) beds under 70 % relative humidity, maximum design temperature, and design face velocity for a penetration of < 0.175 %, (K ≥ 5.52) ⁺⁺).

+) Removal efficiency and penetration, respectively for ¹³¹I loaded as CH₃¹³¹I.

++) Data calculated by the author; for the assumptions, see page 78, last chapter.

6.1.4 Measurement of other Properties of Activated Carbon

Measurements of the particle size distribution, surface area, pore size and distribution, porosity, hardness, impregnated content, etc. are carried out mainly by the manufacturers of iodine sorption materials and, in some cases, by the filter manufacturers.

In USAEC Regulatory Guide 1.52 (published in June 1973) the determination and indication of the physical properties listed in Table XIV is demanded for each production batch of new activated carbon to be used in filters for the removal of fission product iodine.

Table XIV: Summary of the physical properties to be measured on new activated carbon for fission product iodine removal (excerpt from USAEC Regulatory Guide 1.52, June 1973)

Property	Tested on batch of	
	Base carbon	Finished sorption material
Particle size distribution	-	yes
Hardness	yes	-
Ignition temperature	-	yes
Surface	yes	-
Removal efficiency for elemental iodine	-	yes ¹⁾
Removal efficiency for methyl iodide	-	yes
Retention	-	yes ¹⁾
Moisture content	-	yes
Ash content	yes ¹⁾	-
Bulk density	-	yes
Impregnant content	-	yes
Impregnant leachout	-	yes ¹⁾

¹⁾ One qualification test for a specific type of activated charcoal.

6.1.5 Removing Representative Activated Carbon Samples from Iodine Sorption Filters

If no special facilities are installed in iodine sorption filters, it is not possible in most cases to take representative samples of activated carbon for laboratory tests. Experience has shown that the less volatile fraction of filter pollutants initially can be removed already by the first layer of the activated carbon bed and will migrate into the depth of the bed only slowly. As a rule, there will be an uneven distribution of the pollutant in the filter bed. For a representative sample, the carbon for testing must be taken uniformly over the whole depth of the bed. Direct sampling from the iodine filter may result in leaks. This applies in particular when whole carbon filter cells must be removed for sampling. Leaktight fitting of the newly installed carbon filter cells can be guaranteed only by an in-place leak test, which means considerable additional test expenditure. Also in deep bed filters of the vessel type difficulties are bound to arise because usually the designs do not allow carbon samples to be taken which would represent the entire bed depth of the iodine filter.

One possibility of obtaining representative carbon samples without intruding into the iodine filters proper is the exposure of samples in the bypass. In the Federal Republic of Germany, for instance, at least two carbon samples, so-called "control filters," are required to be installed parallel to each iodine sorption filter in bypass sections which can be closed separately. The depth of the activated carbon bed in the control filter corresponds to that of the actual iodine filter; the activated carbon comes from the original batch loaded in the iodine sorption filter. Sufficiently large inner diameters and the avoidance of narrow radii of curvature of the tubes connecting the control filters with the air ducts, and the use of valves of large cross sections will help to keep the pressure drops in the tubing system of the control filters negligibly small. In this way, the loading of a control filter may be

representative of the loading of the main iodine sorption filter. The control filter is designed so that the carbon layer can be separated into at least two consecutive beds whose removal efficiencies can be measured individually. Therefore, it is possible to determine the increase in poisoning of the activated carbon as a function of time.

One drawback associated with the use of control filters lies in the increased probability for leaks. The leak tightness of a control filter must meet the same criteria as that of the main iodine sorption filter. Since every additional bypass will increase the leak risk, their number and, hence, the number of activated carbon samples available must be minimized. In order to avoid leakages in the carbon layer of the control filter, vertical installation and downstream flow direction are recommended.

Activated carbon samples already tested must not be returned to the control filter because, as a result of the laboratory test (conditioning) they may be no longer representative of the activated carbon in the iodine sorption filter. Thus, the number of test samples available is fixed from the outset, and it cannot be guaranteed that the number of samples planned is sufficient for control over the entire service life of the filter.

6.2. In-Place Testing of Iodine Sorption Filters

6.2.1. Objectives

The removal efficiency that can be achieved by an iodine sorption filter is a function of the removal efficiency of the sorption material under the actual operating conditions encountered and of the leak tightness of the iodine sorption filter installed. Both parameters can be assessed in an in-place test. Leaks are defined as connections between the contaminated and the clean air sides of the iodine sorption filter which give rise to a loss of removal efficiency. This includes the formation of channels in the carbon layer, bypassing of a sagged carbon layer by the gases to be cleaned through uncovered perforated metal sheets and mesh

grids, respectively, insufficient sealing between carbon compartments or cartridges and the rest of the filter cell and, in the case of filter banks, between the filter bank and the wall of the filter chamber; when using carbon filter cells, above all, leakages between face gaskets and mounting frames. Finally, leaking may be expected through bypass and drainage lines with faulty dampers and valves, respectively, through valves not closed, and through the walls of the filter chamber itself to the extent that this establishes a connection between the contaminated and the clean air sides of the iodine sorption filter.

6.2.2. Test Agent

If the in-place test is to provide information both on the true removal efficiency of the iodine sorption material and the leak tightness of the filter, the test agent to be used for the test should meet the following requirements, if possible:

- (1) In view of the high removal efficiencies to be proved, even minute quantities of the test agent should be detected by means of a simple, very sensitive detection technique in a quantitative way and with good reproducibility.
- (2) The removal efficiency of the iodine sorption filter should not be impaired by the test agent.
- (3) The test agent should be useful for enrichment in collection systems ready for immediate measurement by simple devices. This is necessary because filter systems for large volumetric flow rates in most cases will allow only a very low concentration of the test agent to be attained in the exhaust air.
- (4) The test agent should be retained under test conditions practically completely and for long periods of time by intact iodine sorption filters so as to allow sensitive leak detection. Major changes in the desorption behavior of fission product iodine on the iodine sorption material should be recognized without any

additional tests.

- (5) The test agent should allow information to be gathered about the actual status of the iodine sorption material; if the iodine sorption material has been spent, this ought to be proved directly by exposing the filters to the test agent during the in-place test.
- (6) Chemically and physically the test agent should behave largely like the iodine species that determines the penetration of the iodine sorption filter.
- (7) The test agent should have a low boiling point for easy evaporation and in order to prevent it from condensing during the test; it should be adsorbed only a little on the surfaces of the structural materials of the iodine filters including the aerosol filters and ventilation ducts.
- (8) The test agent should not occur as a natural contaminant in the materials used for sampling or as an impregnation of the activated charcoal of the iodine sorption filter.
- (9) Handling of the test agent should involve little technical expenditure. In addition, the test agent should be cheap.
- (10) The use of the test agent should cause no major contamination of the personnel and of the environment of the reactor facility.

The test agents used so far were radioactively labeled elemental iodine and methyl iodide, inactive elemental iodine and various types of freon. None of these test agents meets all the criteria mentioned above, but radioactively labeled methyl iodide comes relatively close to being an ideal test agent.

Methyl iodide labeled with ^{131}I meets all the requirements listed above except for (9). Because of the small quantities (on the order of magnitude of mg) needed in a test carried out in situ the partial vapor pressure at

room temperature is sufficient for rapid and complete evaporation, although the boiling point under atmospheric pressure is at 42.3° C. The expenditure involved in preparing and handling, however, is quite considerable, which makes the substance rather sensitive to cost. If the necessary precautions are taken and highly sensitive measuring techniques are used, also the requirement referred to under (10) above can be met without any limitations. By using a solid state detector it was possible at the author's laboratory, for instance, to increase the sensitivity of detection of ^{131}I by more than a factor of 10. The activity of the test agent used for the in-place test was reduced by a corresponding margin.

With respect to the potential environmental burden caused by radioactively labeled test agents the use of methyl iodide instead of elemental iodine offers the decisive advantage that the ingestion dose which, in the Federal Republic of Germany, must always be estimated taking into account the pasture-cow-milk pathway, is at least two orders of magnitude lower.

Since present nuclear iodine sorption filters only use impregnated carbon suitable for methyl iodide removal, the author can conceive of no arguments that would favor the application of elemental radioactively labeled iodine in in-place tests.

Non-radioactive elemental iodine as a test agent is of no use for filter systems using iodine or iodine salt impregnated types of activated carbon. Moreover, contamination of the samples by natural iodine from the environment is practically unavoidable. Hence, the only test agents other than methyl iodide remaining from the list mentioned above are the freons.

Leak testing iodine sorption filters with freons is a standard testing technique in the United States 577. In principle, the freon test differs from the methyl iodide test in that the test agent is retained on the activated

carbon only by adsorption and penetrates through the activated carbon layer after a time which is a function of the properties of the freon used, the condition of the activated carbon and the volumetric flow rate. By contrast, the ^{131}I used as a test agent in the form of $\text{CH}_3^{131}\text{I}$ is bound to the impregnation of the activated carbon relatively firmly by isotopic exchange or the formation of compounds. Only freons with high boiling points show a retention time sufficiently long for leak tests to be conducted on activated carbon beds of lower depths. On the other hand, the desorption of freons is a process which may take weeks and aggravates the execution of in-place tests because of the increase in the freon background.

Since there is no simple technique of enriching the freons on samplers, the freon concentration must be made high enough in the filter influent to allow a direct measurement to be made of the upstream and downstream concentrations.

For this reason, the iodine sorption filters are exposed to major quantities of test agent during the test. The expenditure involved in concentration measurement in situ during the test is quite considerable, e.g., operation of two gas chromatographs, while in the test using radioactive methyl iodide the measurement of the sample can be done in the laboratory. The sensitivity and reproducibility of freon tests is lower than that of the test using radioactive methyl iodide. Of the requirements listed above, (1) is met only partly, (2) to an unknown extent, (3) - (6) are satisfied not at all, (7) partly, and (8) - (10) are met completely. The freon test must be regarded as a pure leak test; it does not convey any information about the real removal efficiency of the activated carbon in the iodine sorption filter. Its particular advantage lies in the fact that the test agent is not radioactive and does not require expensive precautionary measures to be taken.

The test agents used are tetrachloro difluoro ethane (R-112) or trichloro monofluoro methane (R-11). R-112 melts at 26°C

and boils only at 92.8° C. It must be evaporated by heating. R-112 is retained relatively well by the activated carbon and penetrates through an iodine sorption filter with a bed depth of 2.5 cm too quickly during the test only if the fresh activated carbon has absorbed more water than approximately 30 % of its own weight. The very long period of desorption (on the order of weeks) aggravates the execution of in-place tests.

R-11 already boils at 23.8° C. For vaporization it must be heated slightly. R-11 can be used to test iodine sorption filters with a bed depth of 2.5 cm and new activated carbon up to a water content of approximately 12 % of the weight of the activated carbon itself; at higher water contents of the activated carbon, R-11 will penetrate so quickly that the result of the leak test is no longer unambiguous $\angle 587$.

6.2.3. In-Place Testing of Iodine Sorption Filters with Radioactively Labeled Methyl Iodide

In-place tests of iodine sorption filters with radioactively labeled methyl iodide (for the preparation, see Section I, Annex) are based on measurements of the concentration of the test agent in the influent and effluent of an iodine sorption filter. Small aliquots of the influent and the effluent are sampled at the same time and passed through iodine samplers equipped with impregnated activated carbon. The radioactivity trapped in the iodine samplers is measured. The test method is described in more detail in Section IV of the Annex.

The test agent for the in-place test may be prepared in a portable system (e.g., a glove box) at the point of test and may be introduced immediately $\angle 597$ or it may be produced in a laboratory and brought to the point of use in a shielded transport vessel. The author favors the latter technique, because the hazards associated with the preparation of radioactive material can be brought under control more efficiently when working in a radiochemical laboratory with the proper facilities. At the author's

laboratory, a transport container system for the test agent has been developed which satisfies all the safety requirements and allows accurately dosed aliquots of the test agent to be fed out of the total quantity stored (see Fig. 14, Annex). In this way it is possible to produce in one step the test agent for the preliminary tests and the main tests of several iodine sorption filters. Depending upon the sensitivity of detection that must be achieved and the volumetric flow rate at which the respective iodine sorption filters must be tested, a total activity of up to approximately 10 mCi of $\text{CH}_3^{131}\text{I}$ must be used.

When a well shielded solid state detector is used, an activity of 5 mCi will be needed, for instance, to test an iodine sorption filter for a volumetric flow rate of 30,000 m^3/h and for a leak or a penetration of $\geq 0.01\%$. The environmental burden brought about by the introduction of radioactive material into the exhaust air stream can be reduced to practically insignificant levels by a preliminary test of the iodine sorption filter (see Section IV.4, Annex).

6.2.4. In-Place Testing of Iodine Sorption Filters with Freons

In-place tests with freons can be used and evaluated only to detect mechanical leaks between the upstream and downstream sides of iodine sorption filters. Performing the freon test, a freon concentration as constant as possible is produced in the filter influent and the upstream and downstream concentrations of freon are measured by means of gas chromatographs and electron capture detectors or by means of halogen detectors. The ratio between the upstream and downstream freon concentrations, extrapolated to the beginning of the test, indicates the penetration, which is a measure for the size of the mechanical leak.

If a gas chromatograph with an electron capture detector is used, an extremely high sensitivity of detection to alkyl halides can be achieved. For freon-11 (CCl_2F) and freon-112

($\text{CCl}_2\text{F}-\text{CCl}_2\text{F}$) lower limits of detection are indicated in the literature of 0.0003 and 0.001 ppm, respectively [607]. During the test, samples of the influent and, at intervals of one minute each, several samples of the effluent must be taken from the filter system and injected into the gas chromatograph. The freon peak detected after separation in the separation column of the gas chromatograph is registered by a recorder. From the integral of the peak area the amount of freon in the sample and from this the concentration in the gas flow is calculated.

Since the freon in addition to the transport through leakage paths can penetrate through the activated carbon bed of the iodine sorption filter within a matter of minutes, it is necessary to take at least 3 consecutive air samples downstream of the filter within the shortest possible intervals immediately after the onset of the freon injection. The leak rate at the onset of injection (T_0) is determined by extrapolation to T_0 of the measured concentrations at various times. In this way the fraction of freon passing through the iodine sorption filter as a result of a mechanical leak can be separated by calculation from the fraction of freon already desorbing from the activated charcoal at the time the sample is taken. For sampling and recording one gas chromatogram a minimum time of approximately 1 minute is needed.

Depending upon the leak tightness, a difference in concentrations of 100 \rightarrow 10,000 can be expected between freon concentrations upstream and downstream of the iodine sorption filter. Therefore, a sufficiently high freon concentration must be established in the filter influent. The upstream air samples must be diluted before the measurement because of the sensitivity and the insufficient linearity of the detector in the region of high concentrations. This may turn out to be one additional source of error.

By using measuring equipment such as halogen detectors, which allow a continuous measurement to be made of freon

concentrations upstream and downstream of the filter, most of the disadvantages referred to above can be removed. However, the sensitivity of detection of these instruments is much lower than that of an arrangement of a gas chromatograph and an electron capture detector. For instance, ranges of detection between 20 and 1000 ppm and 0.02 - 1 ppm of freon-11 are indicated for halogen detectors if different measuring principles are applied (measurement of ultraviolet absorption and conductivity, respectively).

Measuring the freon concentration requires the use of measuring instruments calibrated with great accuracy. Subsequent calibration before performing the in-place test appears to be necessary because of uncontrollable effects during transport. It might be advisable to use standard calibration mixtures which can be carried along in pressurized cylinders. More recently, calibrating samples have been offered commercially which consist of a saturated adsorption bed and will release reproducible quantities of freon at a specific temperature and flow rate of the carrier gas 617.

Freon-11 may be introduced into the influent air of the filter from a pressurized cylinder through a needle valve while being heated slightly. In this way it is easy to achieve a uniform concentration in the influent air of the filter. Freon-112 would have to be heated much more strongly and would partly condense again in the feed line to the ventilation duct. For this reason, the precipitation of a "solid" film of freon-112 on the inside of a cooler is suggested which is kept at a constant temperature by a liquid during the test and is swept by a uniform flow of carrier gas 607. In the same reference, information is given about the release rate of freon-112 as a function of the cooler temperature and the air flow. At 18° C cooler temperature and a volumetric flow rate of 5 l of air per minute, approximately 1.8 g of freon-112 is released per minute as a gas when the saturation condition has been reached.

The use of highly volatile freon-12 (CCl_2F_2 , boiling point -29.8°C) cannot be recommended because of the short retention time and the lower sensitivity of detection (0.03 ppm when using an electron capture detector).

Since the retention time of the freons adsorbed onto the activated carbon is a function of the pre-loading of the activated carbon with water, solvents and other substances, the freon leak test is recommended only for iodine sorption filters with new activated carbon and longer residence times, respectively. Iodine sorption filters with inorganic iodine sorption materials cannot be tested with freons.

6.2.5. Validity of In-Place Tests of Iodine Sorption Filters with Respect to the Removal Efficiency under Emergency Conditions

Usually, in-place tests can be carried out only under normal operating conditions of the iodine filter systems to be checked. The penetration measured with radioactively labeled methyl iodide as a test agent in the in-place test can be regarded as sufficiently conservative for the removal efficiency of the iodine sorption filter relative to a fission iodine mixture of unknown composition, if the most adverse operating conditions do not differ greatly from the test conditions. To assess the penetration to be expected, above all, the influence of the relative humidity of the air must be taken into account, which may be much higher under reactor accident conditions. Extrapolation of the penetration measured in in-place tests to higher humidities of the air is associated with major uncertainties for the following reasons:

- (1) The activated carbon is frequently not in an adsorption-desorption equilibrium with the water vapor contained in the influent air while the iodine filter is tested. (For this reason, no accurate correlation is possible between the humidity of the air, which is easy to measure in an in-place test, and the penetration).

- (2) The same dependence should not be expected between the humidity of the air and the penetration of the activated carbon in use as that found in laboratory experiments with new activated carbon.
- (3) The penetration determined by the in-place test is the sum total of the leak rate due to mechanical leaks and the sorption properties of the activated carbon, and the contributions made by the different effects cannot be defined without additional laboratory tests of an activated carbon sample from the iodine sorption filter or the control filter in the bypass.

However, considerable aging and poisoning of the activated carbon can be detected also by the in-place test with radioactively labeled methyl iodide under normal operating conditions. But accurate information about the penetration of the iodine sorption filter under emergency conditions and the status of the activated carbon, respectively, can be generated only by the additional laboratory test referred to above of representative activated carbon samples taken from the iodine sorption filter or the control filter.

The combination of various effects upon an iodine filter occurring after major accidents may give rise to loads whose consequences cannot be seen either from the result of the in-place test or the laboratory test. For this reason, a type test of emergency iodine filters under simulated post-accident conditions appears to be necessary as a supplement. A technical filter test installation equipped with the necessary instruments in which temperature, pressure and humidity of the air, the amount of condensate produced and mechanical stresses can be simulated is described in the literature /627.

7. Experience in Operating Iodine Filter Systems

The relatively large number of data published in the literature on the removal efficiencies of iodine sorption filters contains only some information about the removal

efficiency of filters relative to the real fission product iodine mixture released by fuel elements during normal reactor operation or in an accident. This contrasts with an abundance of data on the leak rate and the removal efficiency of iodine sorption filters relative to test agents such as, above all, radioactively labeled methyl iodide.

7.1. The Occurrence of Mechanical Leaks

The occurrence of leakages in the use of activated carbon filter cells is the subject of frequent reports [63, 64]. Various causes of the occurrence of mechanical leaks and possible leakage pathways have been referred to already in Section 5.3 and Section 6.2.1. From more recent publications, for instance, the references quoted under [65] to [67], it can be seen that there are filter designs which have not shown any leaks in practice. In general it can be said that iodine sorption filters properly designed as gasketless deep bed filters of the vessel type have produced excellent results in operation, also as far as their mechanical leak tightness is concerned.

At the end it should be mentioned that filter systems have repeatedly been caused to leak as a result of the malfunction of bypass valves which by error had not been closed after maintenance work or had become defective. Also badly designed control filters have often caused mechanical leaks.

7.2. Poisoning of the Iodine Sorption Material

The most topical problem today, as far as reliable observation of the required removal efficiency of iodine sorption filters is concerned, is caused by the extremely rapid decrease of removal efficiencies frequently experienced as a result of the adsorption of such filter pollutants as solvents and oil vapors in the iodine sorption material [63, 65, 68, 69]. This effect has probably long been underrated in its consequences. This applies in particular to the operation of iodine sorption

filters in newly built nuclear power stations where large quantities of organic solvent vapors from paints and plastics and other organic materials can be released into the room air and finally cover the surface of the activated carbon. When studying activated carbon samples from exhaust air filters of plant compartments, the author's laboratory found solvent inventories of up to 12 % of the weight of the carbon sample after six months of operation of the iodine sorption filters [97].

Table XV compares the removal efficiencies measured for new activated carbon samples with those found for the same batches after use in the control filters located in the bypass to the iodine sorption filters. The samples from the control filters can be regarded here as being representative of the activated carbon in the iodine sorption filters, because the batch of activated carbon, the bed depth, the period of operation and the composition of the filter influent air are identical and the number of air changes referred to the volume of the activated carbon charge agrees sufficiently well.

Table XV: Removal efficiencies of iodine sorption filters initially and after the first six months of filter operation in a newly built nuclear power station ¹⁾

No.	Iodine sorption filter for cleanup of	Residence time at nominal flow ∠ s 7	Removal efficiency on startup ∠ % 7	Removal efficiency after 6 months of operation ∠ % 7
1	Exhaust air of plant compartment	1.0	> 99.994	82.8
2	"	1.0	> 99.994	77.9
3	Exhaust air of annular room	1.0	99.994	97.7
4	Recirculation air of plant compartment	0.4	> 99.99 ²⁾	28.9
5	"	0.4	> 99.99 ²⁾	73.9

1) Determined in a laboratory test under simulated operating conditions with respect to temperature, relative humidity and face velocity of the air. Test agent: $\text{CH}_3^{131}\text{I} + \text{CH}_3^{127}\text{I}$.

2) Estimated from measurements on batches of activated carbon of the same type.

Except for example No. 3 (emergency standby filter for the annular room exhaust air loaded initially only by test runs and the diffusion of pollutants), all the activated carbon samples showed high contents of solvents. In the iodine sorption filter listed under No. 1, solvent loadings of 11.5 and 6.8 %, respectively, were measured in

the first and second halves of the activated carbon layers. The value averaged over the whole bed depth amounted to 9.2 %. In example No. 2, the following levels were measured as listed in the respective sequence: 9.9; 9,7 and 9.8 %. Gas chromatographic analyses detected o-, m-, p-xylene, toluene and fractions of the petroleum-gasoline fraction.

The release of solvents from paint coats and plastics is most pronounced in the first few months of operation, provided that the paint work has been finished.

Measurements of activated carbon samples from iodine sorption filters in older nuclear power stations showed clearly lower solvent contents and correspondingly longer filter service lives.

To prevent avoidable solvent loading of iodine sorption filters the author makes the following recommendations with respect to the construction phase of a nuclear power station:

- The test runs of the fans of iodine filter systems should be carried out before loading the iodine sorption filters with activated carbon.
- The iodine sorption filters should be loaded with activated carbon as late as possible after termination of the paint work on the containment and the annular rooms.

After start-up of the nuclear station,

- solvents should be used sparingly in rooms ventilated through iodine sorption filters;
- the exhaust air of rooms in which paint work is carried out should not be passed through iodine sorption filters, if possible and permissible.

A problem to be studied with high priority is whether the paint coats in rooms of the containment and the annulus can be made of materials containing only a minimum amount of solvents.

Such typical solvent constituents as toluene, xylene and ethyl acetate are not retained for a sufficiently long time (several months) by activated carbon prefilters of dimensions whose use in nuclear power stations is still meaningful.

However, since also less volatile pollutants, (e.g., components of the petroleum-gasoline fraction) occur in the influent air of the filters, it is nevertheless meaningful to protect the iodine sorption filters by suitable activated carbon prefilters. Studies carried out to this effect on multi-stage iodine sorption filters in older reactor systems indicated a marked decrease of the removal efficiency of the first activated carbon filter bank in the flow direction, whereas the second filter bank over the same period of service life as a rule achieved higher removal efficiencies. Corresponding results were found also in measurements of the removal efficiencies of successive layers of deep activated carbon beds /657.

The problem of the pollutant loading of iodine sorption filters is a complex one; it is dependent upon the pollutant concentration in the specific influent air and its development as a function of time, the adsorption behavior of the different pollutants on the iodine sorption material, and the design and operating conditions of the iodine sorption filter. For this reason, only very general recommendations can be made above and beyond the measures quoted above; presently, sufficient information is not yet available about the optimization of measures of process technology. On the basis of experimental work, the author recommends the following measures for better control of the pollutant load:

- Increasing the amount of activated carbon by a margin of at least $2/3$ of the design quantity to create additional capacity to offset the loading by highly volatile pollutants with relatively short penetration times (e.g., typical paint solvents).

- Breakdown of the bulk quantity of activated carbon into two successive layers, the first of which should be replaced within shorter intervals (expected interval: several months), whereas the second layer in the direction of flow can stay in use over prolonged periods of operation (anticipated time: \geq one year). In this way, the pollutants with longer retention times can be removed with the first layer of activated carbon from time to time and no longer contribute much to the loading of the second layer.
- Periodic heating out of the adsorbed highly volatile filter pollutants, e.g., by means of an air heater which would have to be installed between the two layers of activated carbon.

Since preliminary studies have indicated that the solvent retention of activated carbon is not greatly impaired by the usual (low) iodine salt impregnation, it appears to be meaningful to use activated carbon impregnated in this way also for the first activated carbon layer of a two stage filter. This means that a higher overall removal efficiency can be expected over both filter stages also with respect to organic iodine compounds.

Finally, it should be indicated that various iodine filter systems have shown loadings of the activated carbon with water as a result of a temperature drop in the influent air and in the activated carbon, respectively, below the dew point. In some cases, this resulted in a practically complete loss of removal efficiency relative to radioactively labeled methyl iodide. It was found in various cases that exhaust air with a relatively large amount of moisture, for instance from the suction system above the fuel element storage pool, was fed to the iodine filter system through unheated ventilation ducts not thermally insulated. In one extreme case, uninsulated ventilation ducts extended over a distance of more than 50 meters between two buildings, running right through the outside atmosphere.

Also as a result of the influence of NO_2 forming under the impact of intensive gamma radiation in the air, a major decrease of the removal efficiency of iodine sorption filters was observed [707]. In this case a reaction between the NO_2 and the activated carbon must be assumed in which NO and CO are formed and which leads to a loss of activated centers on the surface of the carbon. Reference has already been made to other factors causing the activated carbon to age.

7.3. Fires in Iodine Sorption Filters

Fires in iodine sorption filters have so far been reported in only a few cases. In a list recently published [717] of problems in nuclear air cleaning systems in the period between 1966 and 1974, only two fires of iodine sorption systems are mentioned. In one case, the cause was careless handling of a welding torch on a filter casing, in the other case it was a short circuit in the electric heater of the iodine filter.

Since there have been no major accidents so far involving high releases of activities in nuclear power stations, an assessment of the probability of filter fires arising out of the consequences of accidents can be made only by theoretical approaches.

8. Conclusions and Recommendations

In the compilation of this report a number of open questions were detected which cannot be answered sufficiently well by the literature available so far and which make additional studies very necessary.

For instance, the iodine species emitted by nuclear power stations should be identified by measurements in the vent and stack releases so that more realistic weighting of the total discharge is possible with respect to the pasture-cow-milk pathway. Inadequately conservative assumptions, which may seriously impede the development

of nuclear power, could perhaps be revised as a consequence.

The performance of simple techniques and simple equipment to be used for the identification and classification, respectively, of the percentage fractions of different species of fission product iodine mixtures in the exhaust air should be clarified in intercomparison tests (see Section 2.2., pages 17 - 19).

The techniques and equipment to be selected as a consequence should be used for a very broad measurement program. This should allow a correlation to be made between the results of qualitative and quantitative measurements of iodine releases and the level of milk contamination they cause under the given set of boundary conditions. Since the number of nuclear power stations in operation on sites satisfying these criteria (dairy farm at a suitable distance and location) is small, a centralized coordinated measurement program on an international basis is recommended. In the long run, the behavior of the penetrating iodine compounds to be identified should be clarified on the transport pathway into the environment of nuclear power stations.

As far as the behavior of iodine sorption materials under a prolonged impact of steam-air mixtures at elevated temperatures and high humidity of the gas is concerned, sufficient data are not yet available (pages 41-44). This also applies to the influence of high dose rates of radiation upon iodine already sorbed on iodine sorption materials. With respect to the removal by inorganic iodine sorption materials there is a lack, in particular, of information about the desorption behavior of the fission product iodine trapped as silver salts under the impact of high dose rates of radiation over prolonged exposure times (page 37). These qualification tests of iodine sorption materials can be carried out in only a small number of laboratories equipped with the necessary technical facilities. To avoid unnecessary expenditures

on test facilities it would be meaningful to agree on a division of labor and carry out tests on a commission basis.

It is also proposed to harmonize the test requirements and test methods as far as possible on an international level in order to be able, as a consequence, to set up a central data bank covering the results measured on iodine sorption materials and filters; this data bank should be available for design and comparison purposes. Recommendations on the delineation and establishment of standard test conditions for comparing the removal efficiencies of different batches and types of iodine sorption materials are listed on pages 97 - 100. Moreover, pages 73 - 78 list recommendations about the total scope of the tests to be carried out on iodine sorption materials and on designing the tests for the most adverse operating conditions to be simulated for the respective iodine filter systems.

Since the loading of iodine sorption materials with pollutants and poisons can give rise to a very rapid decrease of removal efficiency, studies on their removal or decomposition upstream of the nuclear iodine filter should be intensified. The development of paints with low solvent contents appears to be an urgent requirement. Measures aimed at improved control of poisoning are listed on pages 97 - 100. In this connection, reference is made to the necessity of installing standby emergency filters separate from other exhaust air filter systems and to operate them only under reactor accident conditions (pages 48 - 50). Also the requirement of sufficient filter redundancy (pages 59 - 60) is mentioned.

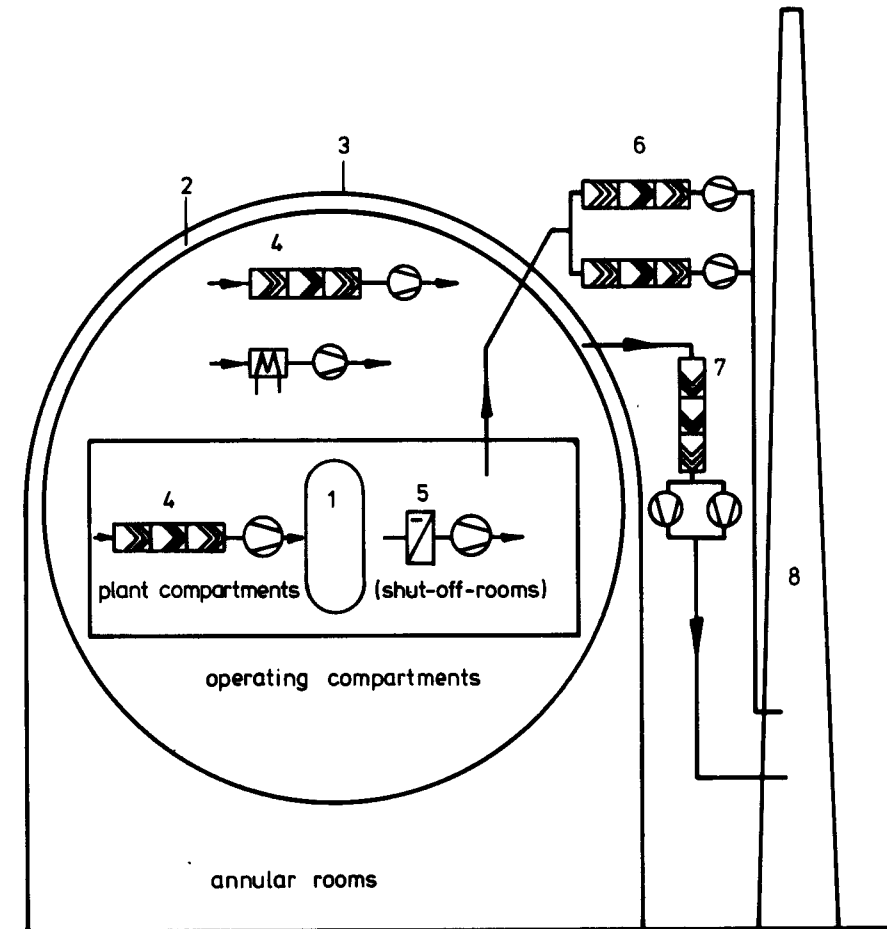
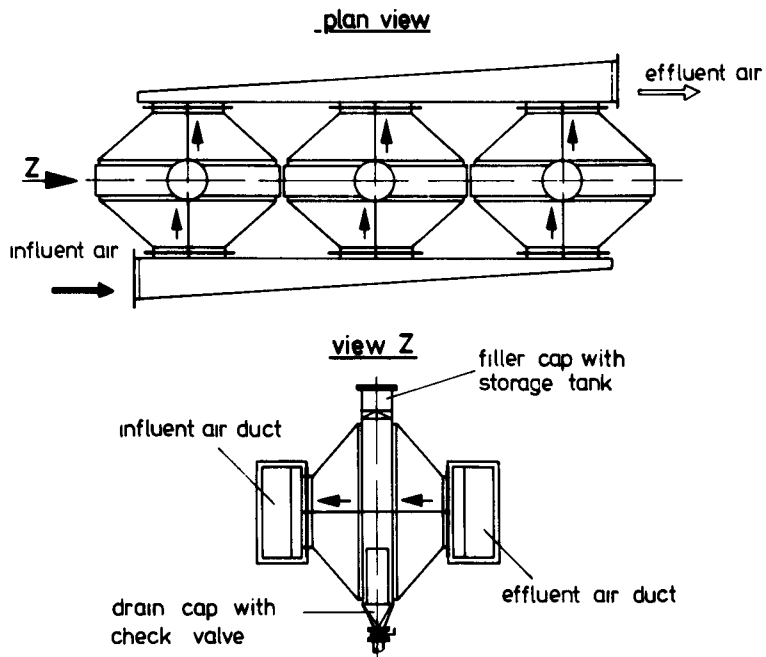

Fig: 1

Ventilation concept of a modern PWR
(simplified diagram)

- | | | | |
|---|---|---|---|
| 1 | Reactor vessel | 6 | Plant compartments purge system with exhaust air filters |
| 2 | Containment | 7 | Annular rooms purge system with emergency standby filters for exhaust air |
| 3 | Concrete shield | 8 | Stack |
| 4 | Internal recirculation air filter system | | |
| 5 | Internal recirculation air cooling system | | |

Note: The meaning of plant compartments and equipment compartments is identical



Example of the installation of vessel type filters

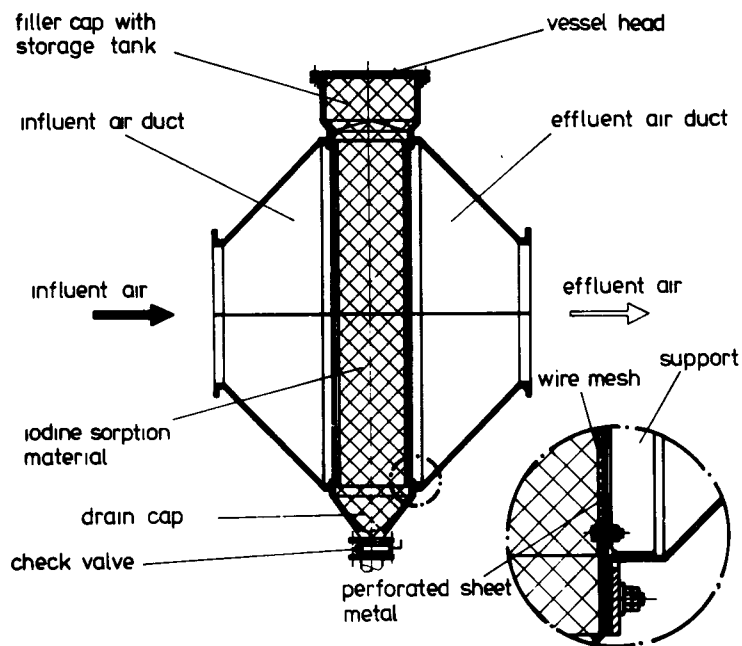

Fig.:2 "Gasketless" deep bed iodine sorption filter of the vessel type with horizontal gas flow (from [52]).

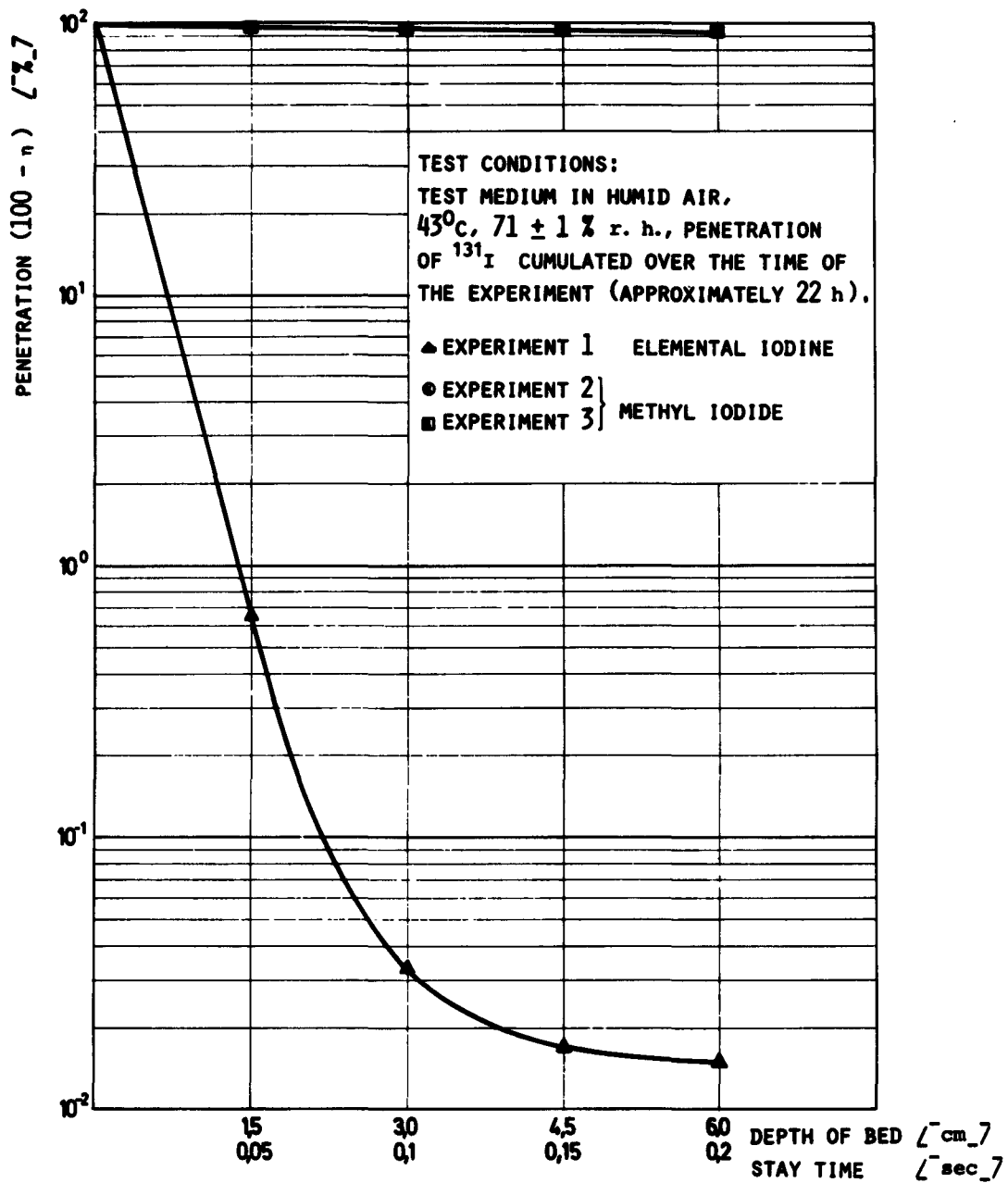

Fig. 3: PENETRATION OF NON-IMPREGNATED ACTIVATED CHARCOAL
 BY ^{131}I IN THE FORM OF ELEMENTAL IODINE AND METHYL
 IODIDE

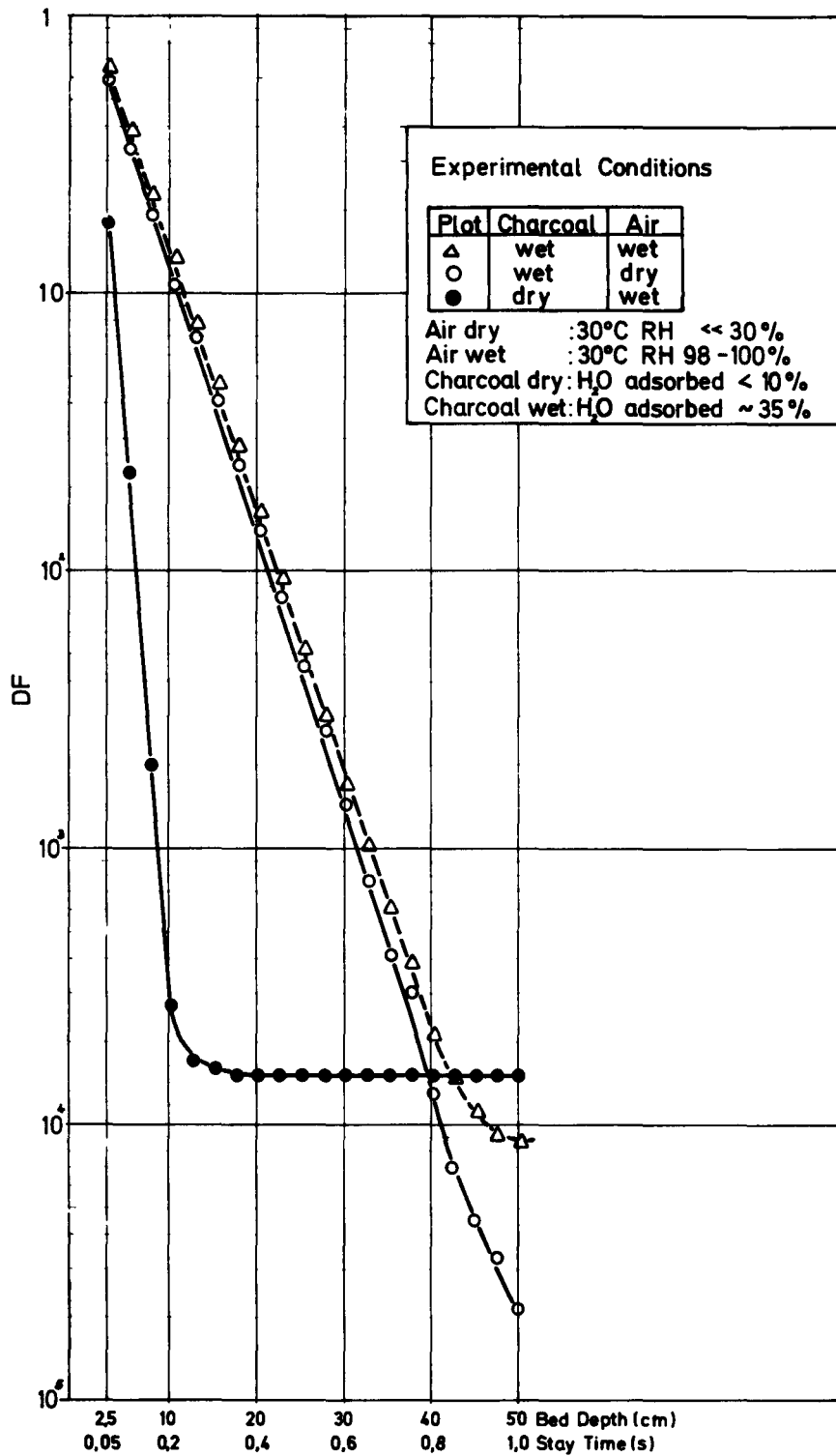

Fig. 4: Penetration of activated carbon beds by ^{131}I (loaded as CH_3I) under various humidity conditions of activated carbon and air

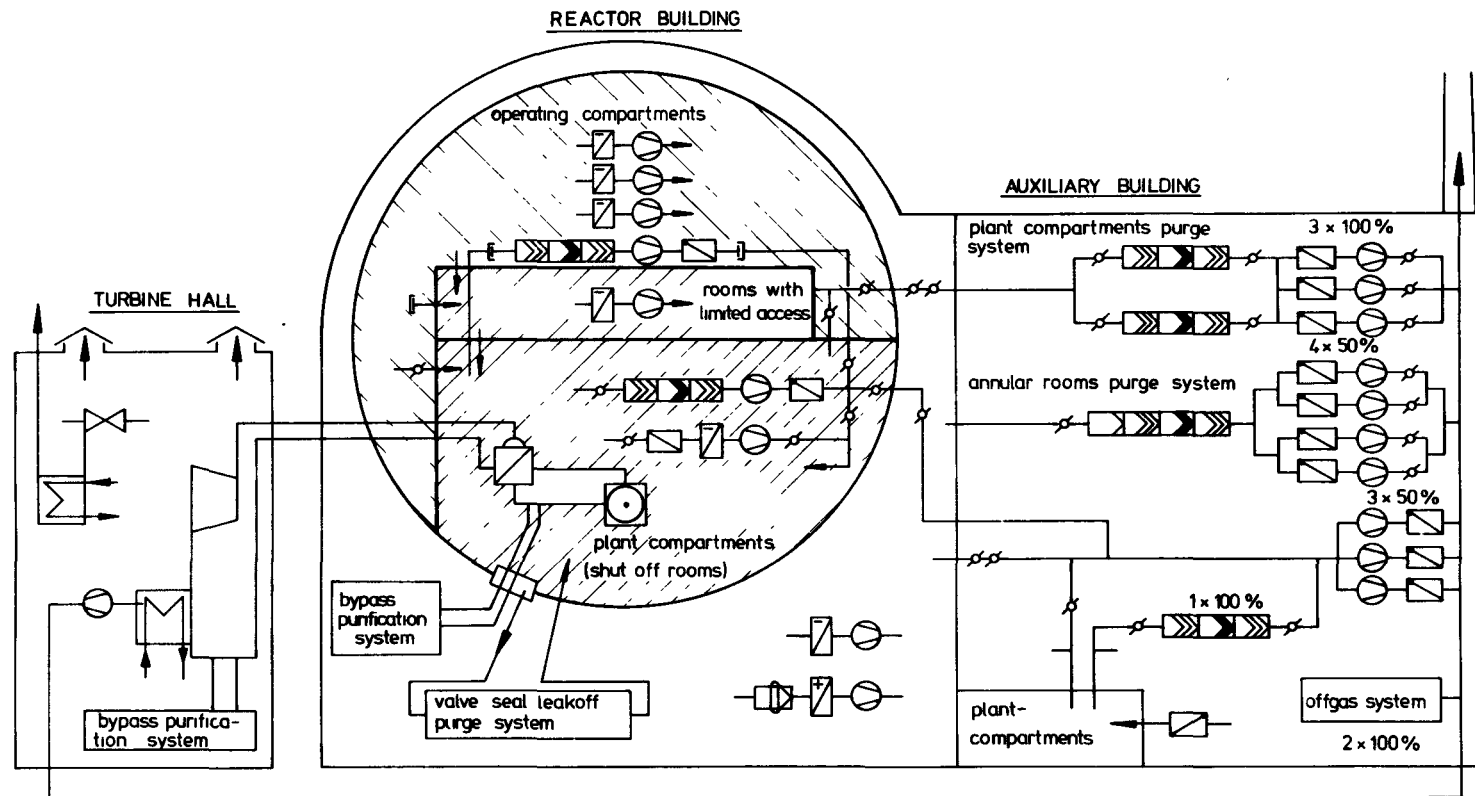
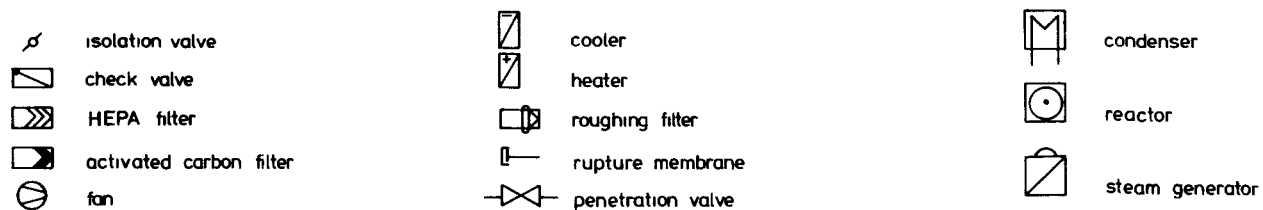

Fig.: 5 Ventilation system of a modern German PWR.



Note: The meaning of plant compartments and equipment compartments is identical

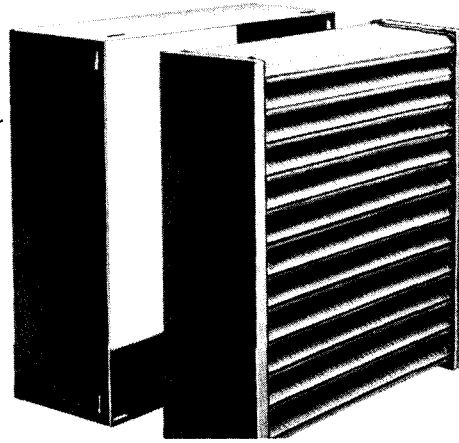

Fig. 6: Pleated-bed carbon filter cell with activated carbon

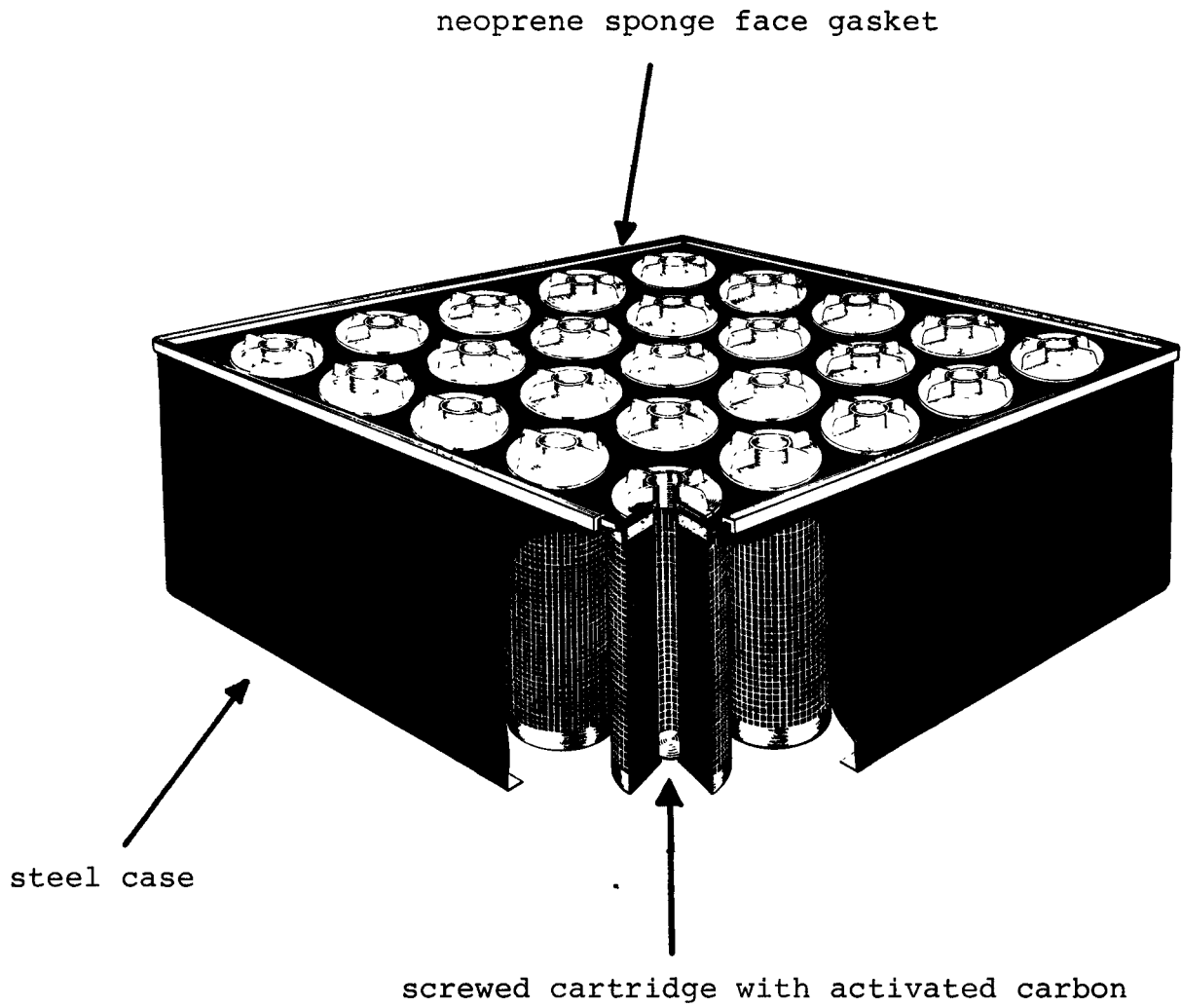
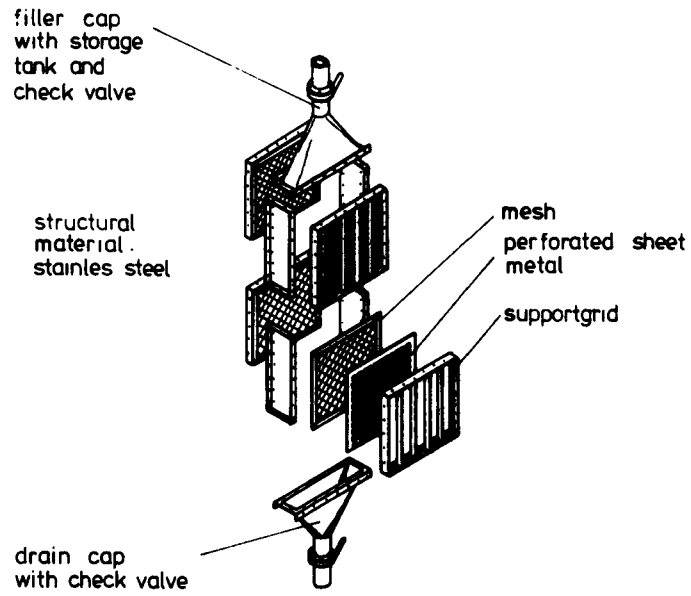

Fig. 7: Cartridge type filter cell with activated carbon



Components of an iodine sorption filter.

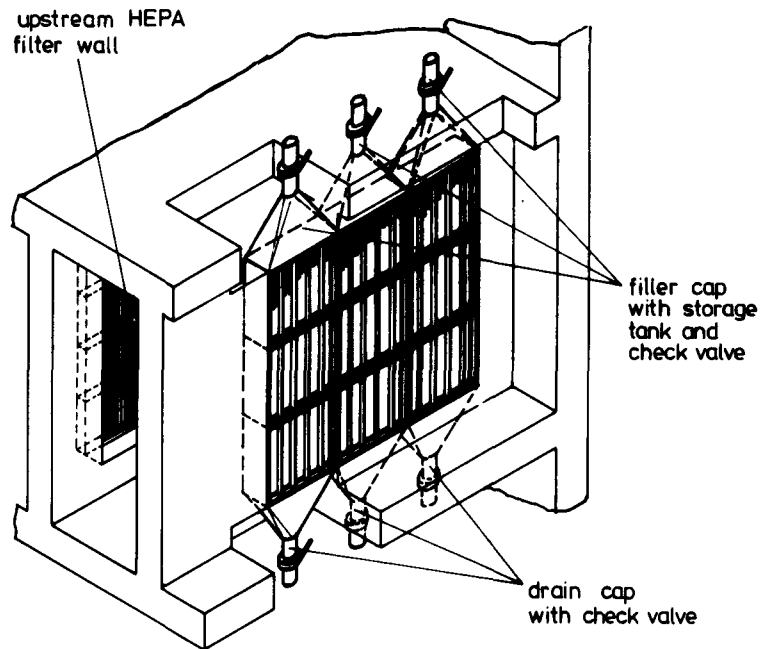

Fig:8 Filter wall with aerosol and iodine sorption filter (from [527])

Literature

- /1/ U.S. Environmental Protection Agency "Environmental Analysis of the Uranium Fuel Cycle, Part II Nuclear Power Reactors," EPA-520/9-73-003-C (Nov. 1973).
- /2/ I. Winkelmann, Bestimmung von Einzelnucliden in Aerosol- und Jodfilterproben aus der Abluft der Kernkraftwerke Gundremmingen, Obrigheim, Würgassen und Stade, Bericht STH-9/74 (August 1974).
- /3/ Private communication by Dr. Kausz, KWU.
- /4/ B.H. Weiss et al., Detailed Measurement of ^{131}I in Air, Vegetation and Milk around Three Operating Reactor Sites, NUREG-75/021 (March 1975).
- /5/ J.G. Wilhelm, Jodüberwachung, in "Raum- und Abluftüberwachung auf Radioaktivität," KFK 1899 (Nov. 1973).
- /6/ USAEC Regulatory Guide 1.42, Revision 1, May 1974.
- /7/ D.M. Golden, R. Walsh, S.W. Benson, The Thermochemistry of the Gas Phase Equilibrium $\text{I}_2 + \text{CH}_4 \rightleftharpoons \text{CH}_3\text{I} + \text{HI}$ and the Heat of Formation of the Methyl Radical.
J. Am. Chem.Soc., p. 87, 4053 (1965).
- /8/ J.F. Kircher, R.H. Barnes, Methyl iodide Formation under Postulated Nuclear Reactor Accident Conditions, Symposium on the Treatment of Airborne Radioactive Wastes, IAEA, Vienna, p.137 (1968).
- /9/ J. Furrer, R. Kaempffer, Alterung und Vergiftung von Jod-Sorptionsmaterialien, in KFK 2195, p. 113 (1975).
- /10/ R.C. Bennet, R. Slusher, R.E. Adams, Reaction of Iodine Vapour with Organic Paint Coatings, ORNL-TM-2760 (1970).

- /11/ D.H.F. Atkins and A.E.J. Eggleton, Iodine Compounds Formed on Release of Carrier Free Iodine-131, AERE-M-1211 (1963).
- /12/ J.J. Hillary, The Behaviour of Iodine Species in the Windscale AGR, EURATOM Seminar on Iodine Filter Testing, Doc.V/559/74, p. 25 (1974).
- /13/ F.O. Cartan, H.R. Beard, F.A. Duce, J.H. Keller, Evidence for the Existence of Hypoiodous Acid as a Volatile Iodine Species Produced in Water-Air Mixtures, CONF-680821, p.343 (Dec. 1968).
- /14/ J.H. Keller, F.A. Duce, D.T. Pence, W.J. Maeck, Hypoiodous Acid: An Airborne Inorganic Iodine Species in Steam-Air Mixtures, CONF-700816, p.467 (1970).
- /15/ J.H. Keller, T.R. Thomas, D.T. Pence, W.J. Maeck, An Evaluation of Materials and Techniques Used for Monitoring Airborne Radioiodine Species, CONF-720823, p.322 (1972).
- /16/ A.K. Postma, R.W. Zavadoski, Review of Organic Iodide Formation under Accident Conditions in Water-Cooled Reactors, WASH-1233, (Oct. 1972).
- /17/ P. Handge, F.O. Hoffman, Die zukünftige Strahlenbelastung in der Oberrheinischen Tiefebene durch Aktivitätsemission aus Kernkraftwerken und kerntechnischen Anlagen, in: Strahlenschutz und Umweltschutz, Jahrestagung 1974 des Fachverbandes für Strahlenschutz e.V. in Helgoland, in the press.
- /18/ H. Deuber, Entwicklung von diskriminierenden Jodsammlern, in KFK 2195, p.117 (1975).

- /19/ D.A. Collins, L.R. Taylor, R. Taylor, The Development of Impregnated Charcoals for Trapping Methyl Iodide at High Humidity, CONF-660904, p. 159 (Jan. 1967) and UKAEA Report TRG 1300(W) (1967).
- /20/ G.W. Parker, G.E. Creek and A. Ferelli, Retention of Methyl Iodide by Impregnated Carbons under Ambient Conditions, CONF-660904 (Jan. 1966), p.199.
- /21/ R.D. Collins, Trapping Radioiodine, Nucleonics 23 (6), 55 (1965).
- /22/ M.J. Kabat, Testing and Evaluation of Adsorbers for Gaseous Penetrative Forms of Radioiodine, CONF-740807, p. 765 (1975).
- /23/ F. Billard, J. Caron, G. Chevalier, J. Vandermeersch, The Influence of Physical Parameters on the Adsorption of Iodine-131 by Activated Charcoals. CONF-650407, p. 814 (April 1965).
- /24/ D.T. Pence, F.A. Duce, W.J. Maeck, Developments in the Removal of Airborne Iodine Species with Metal-Substituted Zeolites, CONF-720823, p. 417 (1973).
- /25/ J.G. Wilhelm, Behaviour of Iodine Sorption Materials, EURATOM Seminar on Iodine Filter Testing, vol. II, Doc.V/559/74, p. 77 (1974).
- /26/ C.E. Junge, Air Chemistry and Radioactivity, Academic Press, New York (1963).
- /27/ J.L. Kovach, J.R. Hunt, Iodine Fission Product Mass Transfer in Adsorbent Media, CONF-740807, vol. II, p. 736 (March 1975).
- /28/ R.R. Bellamy, Elemental Iodine and Methyl Iodide Adsorption on Activated Charcoal at Low Concentrations, CONF-740807, vol. II, p. 683 (March 1975).

- /29/ R.R. Bellamy, The Adsorption of Elemental Iodine and Methyl Iodide on Activated Charcoal from Flowing Air Streams at Low Inlet Concentrations, Ph. D. Thesis, The Ohio State University, 1973.
- /30/ A.G. Evans, Effect of Alkali Metal Content of Carbon on Retention of Iodine at High Temperatures, CONF-740807, vol. II. p. 43 (March 1975).
- /31/ H. Schüttelkopf, J.G. Wilhelm, Jodfilterprogramm, in KFK 1365 (1970), p. 110.
- /32/ J. Caron, J. Vandermeersch, A. Charamathieu, M.F. Thal, Piégeage de l'iode et de l'iodure de méthyle à température élevée, Actes du Congrès Saclay, Diffusion des Produits de Fission, p. 285 (1969).
- /33/ A.G. Evans, Effect of Intense Gamma Radiation on Radioiodine Retention by Activated Carbon, CONF-720823, vol. I, p. 401 (January 1973).
- /34/ R.A. Lorenz, W.J. Martin, H. Nagao, The Behaviour of Highly Radioactive Iodine on Charcoal, CONF-740807, vol. II, p. 707 (March 1975).
- /35/ W.J. Maeck, D.T. Pence, J.H. Keller, A Highly Efficient Inorganic Adsorber for Airborne Iodine Species, CONF-68-0821, p. 185 (1968).
- /36/ J.G. Wilhelm, Trapping of Fission Product Iodine with Silver Impregnated Molecular Sieves, Actes du Congrès Saclay, Diffusion des Produits de Fission, p. 265 (1969).
- /37/ J.G. Wilhelm, H. Schüttelkopf, An Inorganic Adsorber Material for Off-Gas Cleaning in Fuel Reprocessing Plants, CONF-720823, p. 540 (1972).
- /38/ J. Furrer, J.G. Wilhelm, Jodfilterung aus der Abluft von Wiederaufarbeitungsanlagen, EURATOM Seminar on Iodine Filter Testing, Doc.V/559/74, p. 185 (1974).

- /39/ K.C. Patil, C.N.R. Rao, J.W. Lacksonen, C.E. Dryden, The Silver Nitrate-Iodine Reaction, J. Inorg. Nucl. Chem., p. 407 (1967).
- /40/ W.C. Schmidt, Treatment of Gaseous Effluents, TID-7534, p. 371 (1957).
- /41/ G.D. Parfitt, A.L. Smith, A.G. Walton, J. Phys. Chem. 69, p. 661 (1965).
- /42/ J.G. Wilhelm, H.-G. Dillmann, K. Gerlach, H. Schüttelkopf, Jodfilterprogramm, in KFK 1565, p. 191 (1972).
- /43/ J.G. Wilhelm et al., Filterprogramm, in KFK 1973, p. 88 (1974).
- /44/ J. Furrer, R. Kaempfer, Verhalten von AC 6120 bei hoher Temperatur, in KFK 2165, p. 4 (1975).
- /45/ H. Schüttelkopf, J.G. Wilhelm, Jodfilterprogramm, KFK 1565, p. 176 (1972).
- /46/ R. Kaempfer, J.G. Wilhelm, Jahresbericht des Laboratoriums für Filtertechnik, KFK 2165, p. 3 (1975).
- /47/ D.T. Pence, F.A. Duce, W.S. Maeck, A Study of the Adsorption Properties of Metal Zeolites for Airborne Iodine Species, CONF-700816, p. 581 (1970).
- /48/ USAEC Regulatory Guides 1.3 and 1.4, Revision 2, June 1974.
- /49/ F.H. Passant, The Design of Iodine Trapping Plants in the U.K. for CEGB Gas-Cooled Reactor Use, EURATOM Seminar on Iodine Filter Testing, Doc. V/559/74, p. 149 (1974).
- /50/ M. Belval, J. Miribel, Utilisation de zéolithes argentées pour le piégeage à haute température de l'iode, reference as under /497, p. 199.

- /51/ J.E. Edwards, T.N. Hickey, Economic Comparison of an Improved Nuclear Filter System Considering Space, Operation, Testing and Maintenance Costs, CONF-740807, vol. II, p. 985 (1975).
- /52/ D. Sinhuber, M. Neumann, H. Stiehl, Gas-Sorptionsfilterwand zur Spaltjod-Abscheidung aus der Abluft von Kernkraftwerken, report of a colloquy at the NUCLEX, Basle, 1975.
- /53/ C.A. Burchsted, A.B. Fuller, Design, Construction and Testing of High-Efficiency Air Filtration Systems for Nuclear Application, ORNL-NSIC-65 (1970).
- /54/ R.W. Zavadoski, H. Gilbert, A.B. Fuller, C.A. Burchsted, Engineered Safety Features Air Cleaning Systems for Commercial Light-Water-Cooled Nuclear Power Plants. A Review of Current Design and Construction Practices, WASH-1234 (June 1974).
- /55/ J.G. Wilhelm, K. Gerlach, Ergebnisse und Erfahrungen aus der Untersuchung von Jodfiltern, EURATOM Seminar on Iodine Filter Testing, Doc.V/559/74, p.465 (1974).
- /56/ L.R. Taylor, R. Taylor, The Ageing of Impregnated Charcoals, EURATOM Seminar on Iodine Filter Testing, Doc V/559/74, p. 121 (1974).
- /57/ ANSI B 79.1; see also D.R. Muhlbaier, Standardized Nondestructive Test of Carbon Beds for Reactor Confinement Application, USAEC Report DP-1082 (1967).
- /58/ K.L. Schreiber, J.L. Kovach, The Evaluation of Field Test Equipment for Halide and DOP-Testing, CONF-740807, vol. II, p. 901 (1975).
- /59/ EURATOM Seminar on Iodine Filter Testing, Doc V/559/74, see Session III "Test Methods for the Performance of Iodine Sorption Systems," p. 211 - 353.

- /60/ G. Messoro et al., Testing Methods for Iodine Filters of Nuclear Plants, EURATOM Seminar on Iodine Filter Testing, Doc. V/559/74, p. 271 (1974).
- /61/ Chand, Ramesh, Improved Permeation Devices, Ecology Board, Inc., Division of Tracor Instruments, Chatsworth, California, USA.
- /62/ H.G. Dillmann, F. Brüderle, J.G. Wilhelm, Der technische Filterprüfstand in Karlsruhe, EURATOM Seminar on Iodine Filter Testing, Doc. V/559/74, p. 353 (1974).
- /63/ J.J. Hillary, L.R. Taylor, Experience at Windscale of Full Scale Iodine Sorption Plant Testing with Methyl Iodide, reference as under /627, p. 361.
- /64/ M. Stead, Experience in Testing Iodine Sorption Plants Associated with CEGB Gas Cooled Reactors, reference as under /627, p. 391.
- /65/ J.G. Wilhelm, K. Gerlach, Ergebnisse und Erfahrungen aus der Untersuchung von Jodfiltern, reference as under /627, p. 465.
- /66/ H.J. Strauss, G. Staschik and K. Winter, Jodfilter für Kernkraftwerke, reference as under /627, p. 163.
- /67/ F.H. Passant, The Design of Iodine Trapping Plants in the U. K. for CEGB Gas-Cooled Reactor Use, reference as under /627, p. 149.
- /68/ J.J. Clifton, Operating Experience of the SGHWR Iodine Sorption System, reference as under /627, p. 405.
- /69/ R.J. Davis and R.D. Ackley, Long Term Effects on Radioiodine Trapping by Charcoal, CONF-720823, vol. I, p.469 (January 1973).

- /70/ A.G. Evans, Effect of Service on Retention of Iodine by Activated Carbon, CONF-700816, p. 539 (1970).
- /71/ D.W. Moeller, Problems in Nuclear Air-Cleaning Systems, Nuclear Safety, vol. 16, No. 4, p. 469 (August 1975).

APPENDIX

I. Methods of Preparing Radioactively Labeled Methyl Iodide and Elemental Iodine

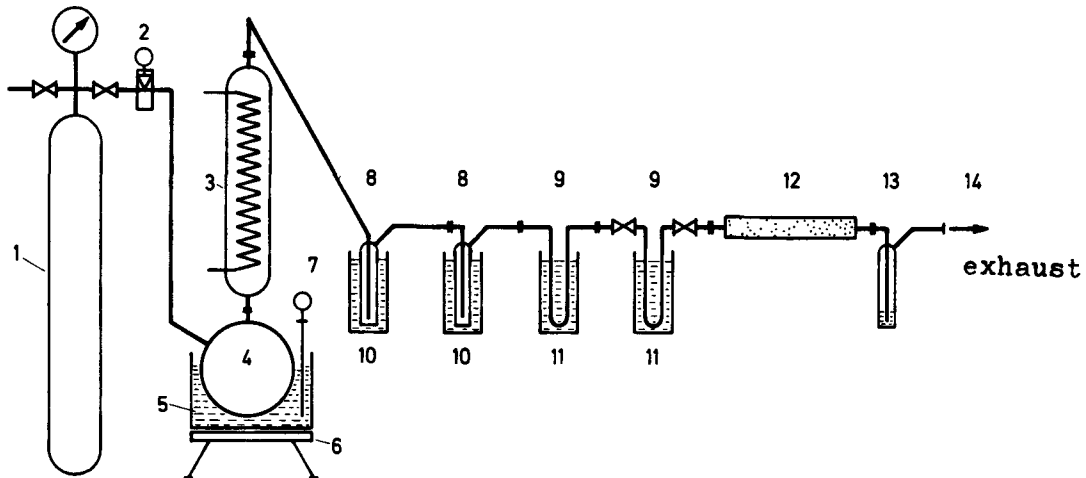

Fig. 9: Apparatus for the preparation of methyl iodide.

- | | |
|--------------------------------------|--|
| 1 Helium pressure cylinder | 8 Water traps |
| 2 Flowmeter | 9 U-tubes |
| 3 Reflux cooler | 10 Dewar flask with CO ₂ /acetone |
| 4 Reaction flask | 11 Dewar flask with liquid N ₂ |
| 5 Water bath | 12 Activated carbon filter |
| 6 Heating plate and magnetic stirrer | 13 Bubble counter |
| 7 Thermometer | 14 To stack |

Fig. 9 shows the flowsheet of an apparatus in which radioactive methyl iodide can be prepared by a reaction of potassium iodide with dimethyl sulfate according to the formula:



The ¹³¹I activity is brought into the reaction flask as K¹³¹I in an aqueous solution to which K¹²⁷I is added as a carrier. A minimum amount of water, a large surplus of fresh dimethyl sulfate and solid, dehydrated CaCO₃ should be used at room temperature or only slightly elevated

temperature. For good yields (80 - 95 %), good stirring is necessary. The evaporated methyl iodide is swept out of the reaction flask by the helium stream, most of the water vapor carried along is removed in the water traps (or, alternatively, by a drying agent such as magnesium perchlorate), and the methyl iodide is trapped in a U-tube cooled by liquid nitrogen. For maximum purity the methyl iodide should be distilled again at a slightly higher temperature and finally condensed in the second U-tube.

Elemental radioactive iodine can be produced by the oxidation of KI, for instance, by the following reaction:

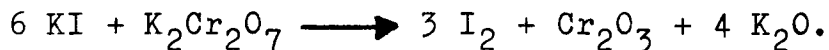

The apparatus required is shown in Fig. 10.

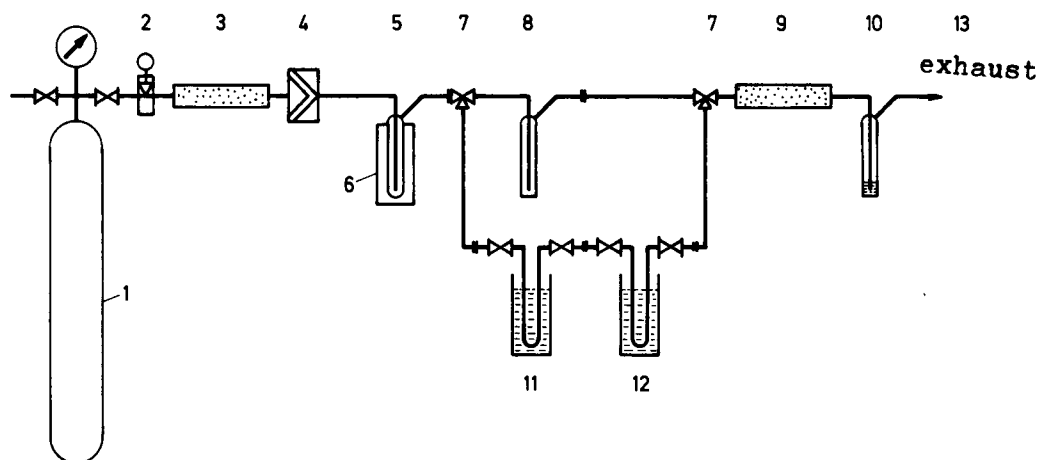

Fig. 10: Apparatus for the preparation of elemental iodine.

- | | |
|---------------------------------------|---|
| 1 Pressure cylinder,
synthetic air | 8 Water trap |
| 2 Flowmeter | 9 Activated carbon filter |
| 3 Drying agent | 10 Bubble counter |
| 4 HEPA filter | 11 Dewar vessel with ice/salt |
| 5 Reaction flask | 12 Dewar vessel with liquid
nitrogen |
| 6 Oven | 13 To exhaust stack. |
| 7 Three-way valve | |

The oxidation of KI with $K_2Cr_2O_7$ furnishes relatively pure elemental iodine, but is rather cumbersome to handle because of the high temperature required for the salt melt reaction (approx. $450^\circ C$). A method of preparing large quantities of elemental radioactively labeled iodine which can be operated continuously is the oxidation of iodine ions with iron-III sulfate in a solution acidified with sulfuric acid (method according to Duflos).

Since these are conventional methods of preparation, no further details will be given here. It should merely be pointed out that the preparation of elemental iodine sufficiently pure is possible only if the work is carried out in glassware completely free from grease and requires another distillation step for the desired end product. When the elemental iodine has been prepared, the "highly volatile fraction," which always occurs in a small amount, should be removed from the sample (U-tube) by short purging right before the introduction into the test apparatus.

II. Test Apparatus for Measuring the Removal Efficiencies of Iodine Sorption Materials

An example of a test apparatus which allows the test conditions to be varied within relatively broad limits is that developed by the Gesellschaft für Kernforschung of Karlsruhe, Federal Republic of Germany, for testing iodine sorption materials under normal pressure.

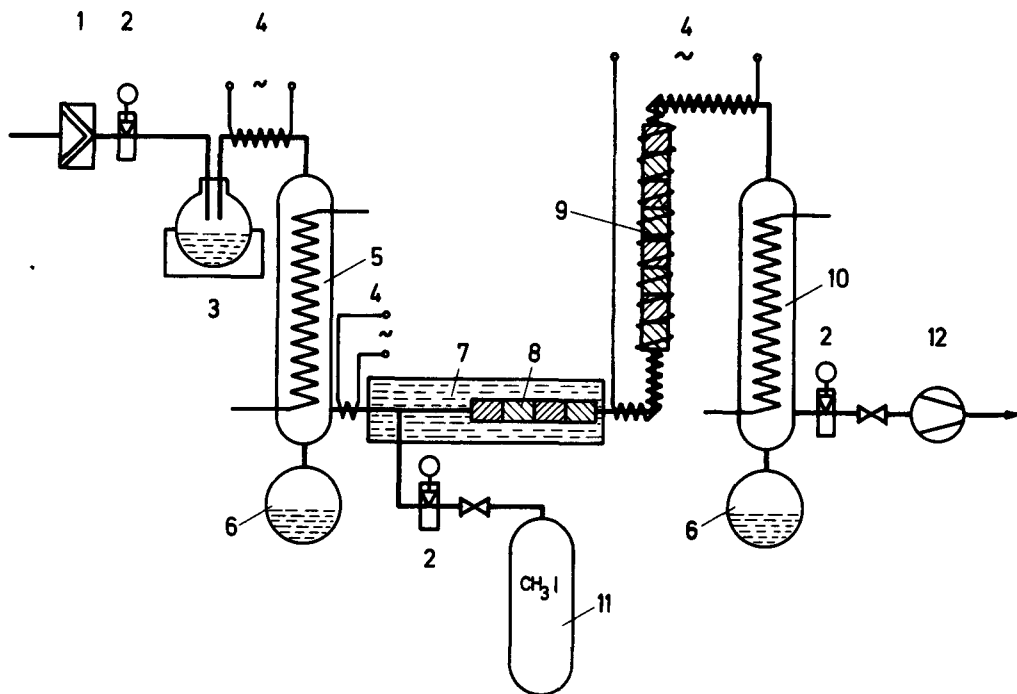

Fig. 11: Laboratory scale apparatus for testing iodine sorption material.

- | | |
|--------------------|---|
| 1 HEPA filter | 7 Thermostat |
| 2 Flowmeter | 8 Test beds of iodine sorption material |
| 3 Evaporator | 9 Safety beds |
| 4 Heater | 10 Cooler |
| 5 Dew point cooler | 11 Pressurized cylinder with test agent |
| 6 Condensate | 12 Pump |

This apparatus, which uses moist air, allows measurements to be carried out in the range between 5 - 100 % r.h. at temperatures of the carrier gas (usually air) between 10 and 80° C and a flow of up to 1.8 m³/h.

The iodine sorption material is loaded on test beds with a diameter of 2.5 cm. Several test beds can be loaded in series up to a bed depth of 50 cm. The iodine sorption material required per test bed is weighed in after the bulk density has been determined accurately. In this way, variations in diameter of the glass tubes used to prepare the test beds do not affect the residence time which must be observed accurately. By vibrating the iodine sorption material with a tamping volumeter reproducible packing densities are achieved and leaks are avoided. The test beds are retained in the glass tubes by wire mesh out of stainless steel for low iodine adsorption; also the springs are made of stainless steel. Abraded material is removed from the test beds with a vacuum cleaner after the vibration step.

The operation of the moist air apparatus shown in Fig. 11 will be briefly described below. Laboratory air is sucked in through a HEPA filter (1). A flowmeter (2) is used to determine the volumetric flow rate. Afterwards, steam from a steam generator (3) is added to the air. The mixture of air and steam is run into a so-called dew point cooler (5) through a heated tube (4) to avoid condensation; the dew point cooler is double walled and has a very closely wound cooling coil. The annulus between the walls is insulated to the outside, and the cooling coils are flushed with the coolant from a cryomat (not shown) counter current to the moist air.

The cryomat regulates the temperature of the coolant within an accuracy of $\pm 0.03^{\circ}$ C. The temperature of the moist air is set to the theoretical level in the dew point cooler and kept constant within $\pm 0.1^{\circ}$ C. The excess water vapor condenses in the dew point cooler and is collected in a flask (6), measured and withdrawn from the flask at

regular intervals. The moist air, now with the dew point set accurately, is removed from the cooler by a weakly heated double walled tube and, as it passes through a long glass tube (7) tempered by a bath thermostat, raised to a given temperature. The bath thermostat is operated at its set level within a margin of $\pm 0.03^{\circ}$ C.

The relative humidity of the air (or any other carrier gas mixture) results from the difference between the dew point temperature set in the dew point cooler and the temperature of the moist air set in the thermostat tube (7). If, for instance, the temperatures of the moist air and the dew point temperature are identical, the relative humidity of the air is 100 %. This assumes that there is no pressure drop between the dew point cooler and the test bed which, at the same time, would result in a reduction of the water vapor partial pressure and in this way decrease the relative humidity of the air. In order to offset this effect, the dew point temperature may be raised slightly.

In order to remove any droplet aerosols remaining in the offgas of the dew point cooler, a roughing filter made of glass fibers (not shown) is installed in the thermostat tube. This will be needed mainly for tests with very high relative humidity of the air. Otherwise, the droplet aerosols occurring in very small quantities would be evaporated as a result of the reheating of the moist air in the tube between the dew point cooler and the test beds (8).

The gaseous $\text{CH}_3^{127}\text{I} + \text{CH}_3^{131}\text{I}$ - mixture used as a test agent will be stored in a stainless steel cylinder (11) pressurized with dried and cleaned air. It will be added to the moist air by means of a flowmeter (2) far enough upstream of the test bed to allow a uniform concentration to be achieved over the tube cross section.

Elemental radioactive iodine as a test agent can be added to the moist air right from the U-tube used in the preparation process. The concentration of elemental iodine is then set via the temperature of the U-tube and the

volumetric flow rate of the carrier gas through the U-tube. The decrease of the ^{131}I radioactivity in the U-tube can be monitored and the iodine concentration in the moist air can be calculated from the release rate.

When using the I_2 generation method according to Duflos, the concentration of iodine in the gas stream is controlled by the dripping rate of the iodide solution into the reaction vessel. The helium used as a carrier gas ensures continuous removal of the gaseous elemental iodine and is directly fed into the moist air of the test apparatus. In this case the pressure cylinder (11) has been replaced by an apparatus for the preparation of elemental iodine.

After passing through the test beds, the mixture of moist air and the test agent is sucked through a heated tube section and through heated safety beds (9) consisting of an iodine sorption material whose removal efficiency is known. Heating reduces the relative humidity of the air below 30 % when it reaches the safety beds. The fraction of the test agent not retained in the test beds is removed by some out of at least eight successive safety beds, as is known from experience. By measuring the radioactivity in the safety beds it is possible to verify the completeness of the removal of the test agent after every experiment. The exhaust air from the safety beds is dehumidified (10), measured and released by means of a membrane pump (12) into the exhaust air of the isotope hood containing the apparatus.

The volumetric flow rate \dot{V}_{TB} of the moist air through the test beds determines the residence time. Since a measurement of \dot{V}_{TB} will be difficult in the presence of extremely high relative humidity of the air, and since the various operating conditions would require a very tedious calibration of the flowmeter, the volumetric flow rate \dot{V}_{L} of the incoming laboratory air (measured downstream of the HEPA filter (1)), which corresponds to \dot{V}_{TB} , is calculated according to the following formula:

$$\dot{V}_L = \frac{\dot{V}_{TB} \cdot T_L \cdot \left(P_L - \frac{\varphi_{TB} \cdot P_{S, TB}}{100} \right)}{T_B \cdot \left(P_L - \frac{\varphi_L \cdot P_{S, L}}{100} \right)} ;$$

where

- T_L = temperature of the laboratory air in $^{\circ}\text{K}$
 T_B = temperature of the moist air in the test bed in $^{\circ}\text{K}$
 P_L = pressure of the laboratory air in mb
 φ_{TB} = relative humidity of the air in the test bed in %
 φ_L = relative humidity of the laboratory air in %
 $P_{S, TB}$ = saturation pressure of the water vapor at T_B in mb
 $P_{S, L}$ = saturation pressure of the water vapor at T_L in mb

The temperature is continuously measured and recorded at all important points of the apparatus (e.g., in the dew point cooler and in the test and safety beds); all heating sections are controlled by contact thermometers and thyristor controllers. The relative humidity of the air is controlled by measuring the temperature of the test bed and the dew point temperature by means of a special unit (operated in the continuous mode). The control system for the moist air equipment operates to an accuracy of approximately $\pm 1\%$ r.h.; the system can be operated unmanned at night and for this reason allows continuous experiments to be performed over several days without requiring additional personnel expenditure.

It is decisive for the reproducibility of removal experiments that the iodine sorption material be in an adsorption-desorption equilibrium with the incoming moist air (see Section 3.3.4.).

Fig. 12 shows the dependence on sweep time and bed depth of the amount of water adsorbed onto the impregnated activated carbon.

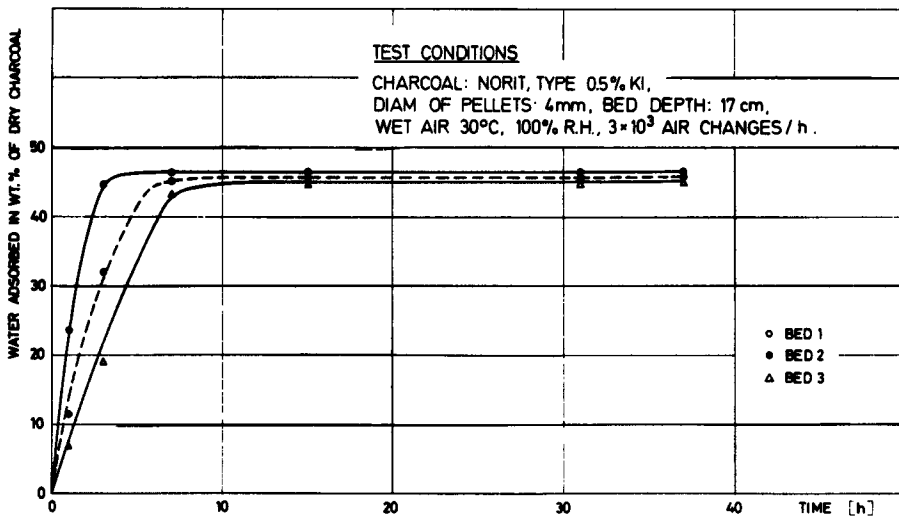

Fig. 12: Water vapor adsorption onto impregnated activated carbon.

Since most studies were carried out for iodine sorption filters with a bed depth of 50 cm, a pre-humidification (conditioning) time of ≥ 20 h was used for activated carbon beds of large depths in order to be on the safe side. As a result of the pressure drop along the test bed there is a decrease of the relative humidity of the air with increasing bed depth under isothermal test conditions. With larger bed depths, this effect results in decreasing amounts of adsorbed water in successive parts of the bed and is clearly evident on Fig. 12.

Fig. 13 shows the design of an apparatus allowing iodine sorption materials to be tested in steam-air mixtures under higher pressures and at high temperatures. Under these conditions the control and setting of temperature, pressure and relative humidity is possible only at a reduced accuracy so that there will be much greater variations of the test results than with the apparatus

shown in Fig. 11. For this reason, the measurement of removal efficiencies at elevated pressures and elevated temperatures, in the author's opinion, is not a suitable standard technique to determine the removal efficiency of iodine sorption materials.

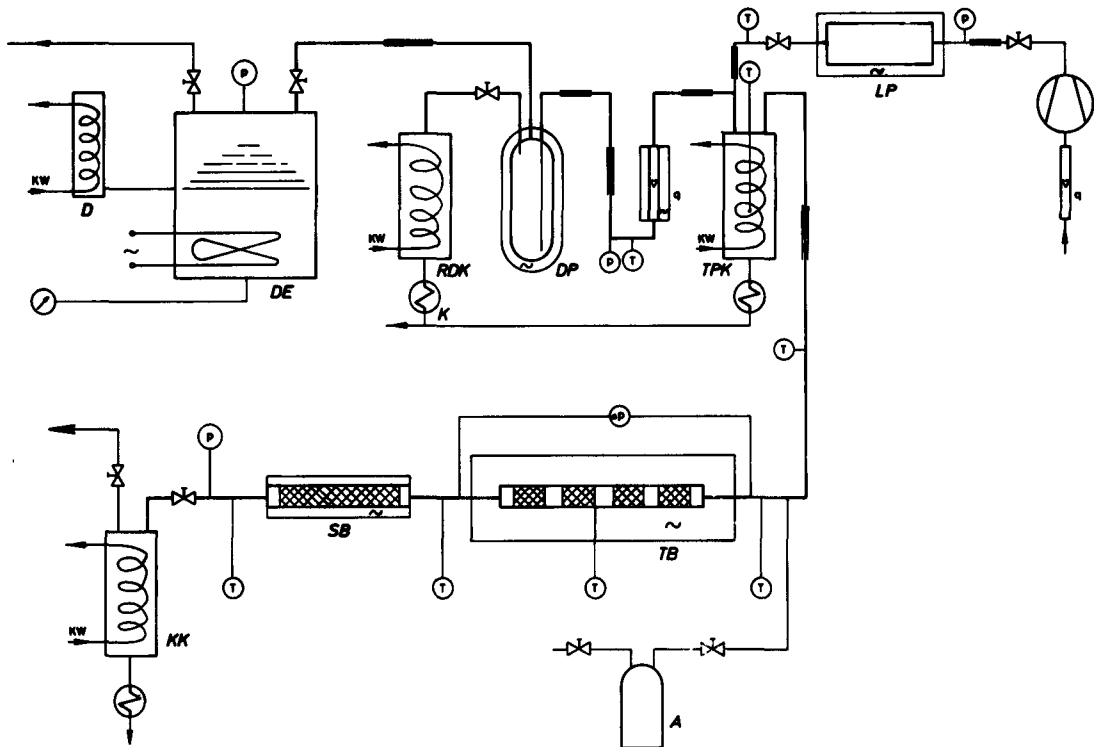

Fig. 13: Apparatus for testing iodine sorption material in steam-air mixtures under pressure and high temperature.

D	Distiller	KK	Condensate cooler
DE	Steam generator	SB	Safety bed
RDK	Reflux steam cooler	TB	Test bed
DP	Steam buffer	A	Pressurized cylinder with radioactive test agent
TPK	Dew point cooler	K	Condensate separator
LP	Air buffer	KW	Cooling water or coolant

III. Evaluation of the Removal Efficiency Tests of Iodine Sorption Materials

In the text below, the evaluation technique usually applied at the author's laboratory will be described. The type of evaluation applied by different laboratories differs mainly in the expenditure involved in measuring gear and data processing equipment.

For evaluation, the iodine sorption material of each individual test and safety bed is transferred into a special plastic bowl and carefully mixed so that a uniform distribution of the radioactivity in the sample is ensured. The radioactivity of each individual bed is determined by measuring the photopeak of the 0.36 MeV gamma line by means of a NaI(Tl) scintillation detector and multi-channel analyzer. Because of the very different radioactivities of the individual samples several measuring positions at different distances from the detector are provided for. The measured results are corrected in a computer program with the geometry factor, the decay time and the background count rate and evaluated both with respect to the individual removal efficiency of each test bed (differential removal efficiency) and the overall removal efficiency as a function of the bed depth (integral removal efficiency). The removal efficiencies in a very simple way result from the ratio of the radioactivity trapped in the test bed considered and the total radioactivity of all test beds and safety beds of the experiment. This evaluation furnishes much more information, and is much more accurate, than any determination of the removal efficiency of a test bed not subdivided by measuring the concentrations of the test agent in partial streams of influent and effluent air by means of iodine samplers. In the latter technique flow variations in the partial streams will influence the measurement badly; also, the radioactivity in the samples will be lower, thus causing larger statistical errors.

The computer program is also used to calculate the differential and integral penetration of the test beds and

the K-factors. For each removal efficiency test a removal profile is drawn (logarithm of the penetration versus bed depth). Leaks in the test beds, errors in the performance of the test, and impurities in the test agent in most cases can easily be recognized from the differential removal efficiencies and the removal profile.

To determine the removal efficiency of a specific iodine sorption material two individual tests are carried out.

The data for the penetrations determined in the individual tests are averaged. The percentage errors in the individual values relative to the mean value are a function of the overall removal efficiency (η) achieved. With a removal efficiency between 99 and 99.9 % in general a deviation of the individual values of the penetrations ($100 - \eta$) from the mean value on the order of ± 30 % is not exceeded. If the deviations are > 50 %, the removal efficiency tests are repeated.

In addition to the removal efficiency, the water adsorption of the iodine sorption material (in % of the dry weight), the loading with the test agent (in μg of test agent per g of carbon) and the pressure drop over the entire depth of the test bed (for a face velocity of the air of 25 cm/s) is determined and recorded for each experiment.

IV. In-Place Test of Iodine Sorption Filters with Radioactively Labeled Methyl Iodide

The following chapters describe the details of the technique presently employed by the author; similar methods can be seen from the literature [597].

IV. 1. Transport of the Radioactive Test Agent

Fig. 14 shows a transport container with the tank for the test agent. This system allows the test agent to be transported practically without any safety problems.

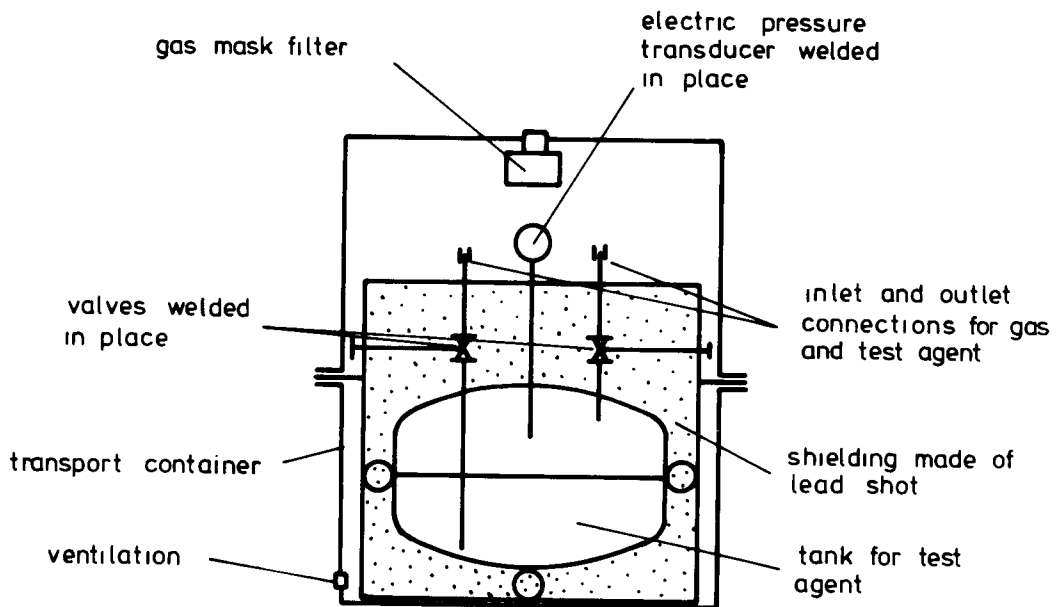

Fig.:14 Transport and feed system for radioactive test agent.

The tank containing the test agent in principle consists of a pressure vessel made of stainless steel and shielded with lead. It is evacuated before being filled and kept under a negative pressure during storage and transport of the test agent. The transport container is continuously exvented through an iodine filter built in; for this reason, no pressure can build up in the interior.

Before being opened the transport container is flushed with pressurized air through the built-in iodine filter. If radioactivity has leaked into the transport container as a result of some mechanical damage to the tank containing the test agent, flushing will transport it to the iodine filter with impregnated activated carbon and retain it there. The activated carbon filter is unshielded; any radioactivity it contains is easy to detect. Even before the transport container is opened, leaking of the tank containing the test agent can therefore be determined and contamination of the environment can be safely prevented. Only after transport to the iodine filter to be tested the atmosphere in the tank containing the test agent will be pressurized with air by means of a small membrane pump. At least two hours should be planned for the test agent and the air pumped in to mix.

The amount of test agent withdrawn can be measured by the pressure relief in the tank with a pressure transducer welded in (electric pressure measurement, no connection carrying radioactivity between the interior of the tank containing the test agent and the measuring instrument). The radioactivity released is calculated by the following formula:

$$A_2 = A_1 \cdot \frac{P_1 - P_2}{P_1} ;$$

where

A_2 = radioactivity of test agent released

A_1 = total radioactivity in the tank at the beginning of the release of test agent

P_1 = pressure in the tank at the beginning of the release of test agent

P_2 = pressure in the tank at the end of the release of test agent.

After one pressurization of the tank, equal reductions of pressure in a sequence of withdrawal periods will correspond to the release of the same quantities of radioactive test agent. Hence, a very easy withdrawal of aliquots is possible.

IV. 2. Test Setup and Test Performance

Fig. 15 shows an iodine sampler for in-place tests. The setup for in-place testing of iodine sorption filters is shown in Fig. 16. The test agent is fed into the air duct upstream of the iodine sorption filter (if possible, a minimum of 10 ventilation duct diameters upstream of the two iodine samplers for the unfiltered air and of the branching of bypass ducts whose valves must also be inspected for leak tightness). Partial streams of unfiltered and filtered air are passed through the iodine samplers (sampling ports of filtered air, if possible, 10 ventilation duct diameters downstream of the iodine sorption filter and the point of discharge of a bypass duct, respectively). The individual activated carbon beds of the iodine samplers are measured by means of an assembly consisting of a solid state detector and a multichannel analyzer.

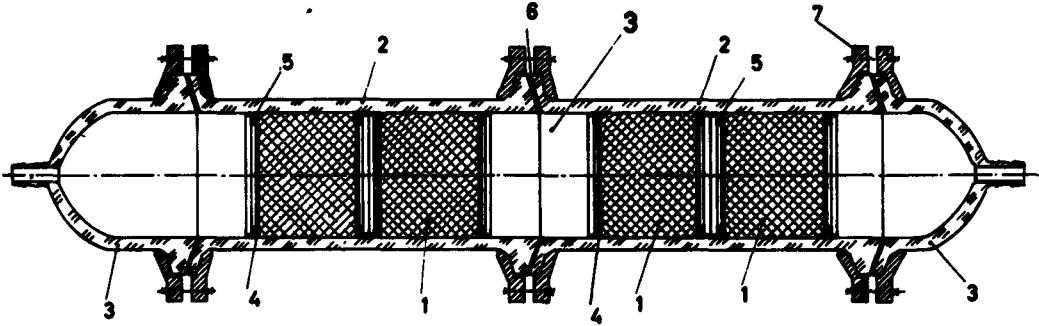

Fig. 15: Iodine sampler.

1. Activated carbon bed
2. Glass or metal tube (stainless steel)
3. Terminal piece for hose connection
4. Wire mesh
5. Spring
6. Gasket
7. Tensioning flange

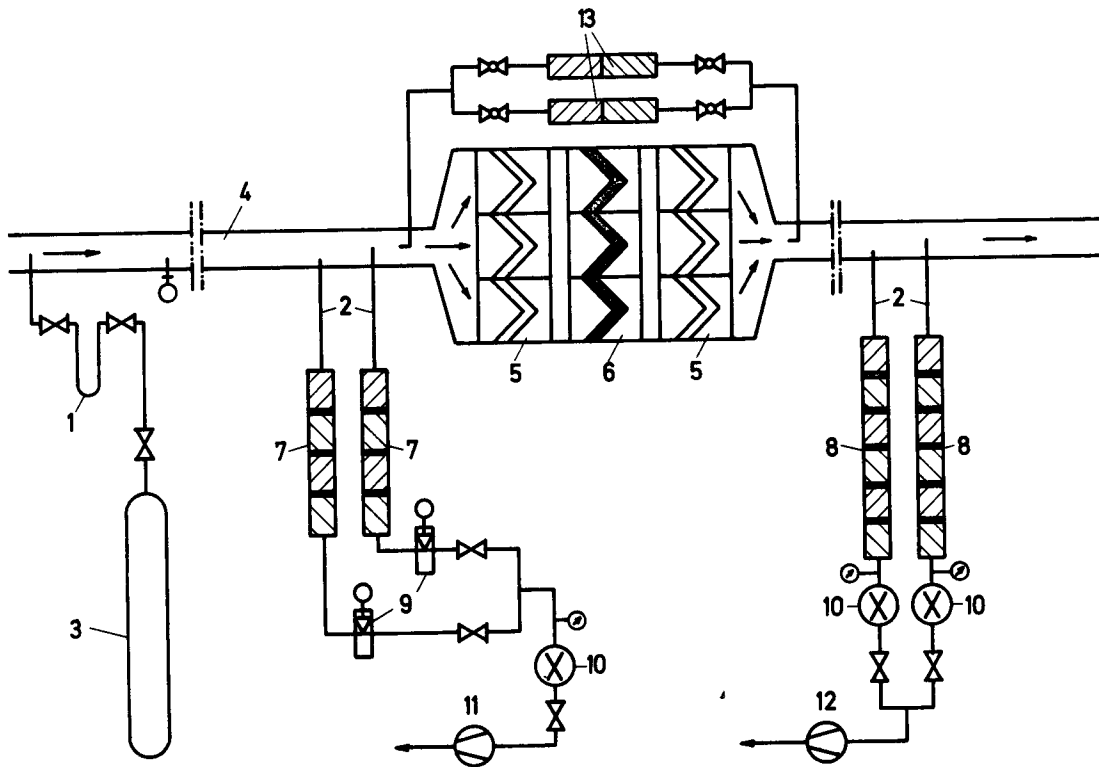

Fig. 16: Setup for the in-place test of an iodine sorption filter.

1 Tank containing methyl iodide	7 Iodine sampler for unfiltered air
2 Sampling tubes	8 Iodine sampler for filtered air
3 Compressed air cylinder or pump	9 Flowmeter
4 Ventilation duct	10 Dry gas meter
5 HEPA filter	11 Pump for sampling unfiltered air
6 Activated carbon filter cells	12 Radial blower for sampling filtered air

IV. 3. Calculating the Required Radioactivity of the Test Agent and the Penetration of the Iodine Sorption Filter

The radioactivity of the test agent to be used in the in-place test must be fixed on the basis of the size of the mechanical leak to be detected. The smallest mechanical leak to be detected, L_{\min} , expressed in % penetration, in

our measurements is mostly determined by a value which corresponds to the quotient of

$$L_{\min} = \frac{\text{maximum permissible penetration of iodine sorption filter}}{100}$$

The radioactivity of the test agent to be used can be calculated from the formula:

$$A_2 = \frac{V_I \cdot 100 \cdot A_B}{V_{Rn} \cdot L_{\min}};$$

where A_2 = radioactivity of the test agent to be used (Ci)

A_B = radioactivity of the first activated carbon bed of an iodine sampler in the unfiltered air (Ci)

V_I = volumetric flow rate through the iodine sorption filter during the test (m^3/h)

V_{Rn} = partial stream through an iodine sampler for the filtered air (m^3/h).

When using a shielded solid state detector, 1×10^{-10} Ci ^{131}I was measured without any difficulties in an activated carbon bed of an iodine sampler. The radioactivity of the test agent to be used for this purpose for most iodine filter systems is in the range between 1 and 10 mCi.

Usually, 150 l/h of unfiltered air and 6 m^3/h of filtered air are drawn through the respective iodine samplers. From the ratio between the radioactivities of the iodine samplers in the unfiltered air and the filtered air the decontamination factors are calculated and the mean value is formed according to the relation of

$$DF = \frac{ZR_{Rh} \cdot V_{Rn}}{ZR_{Rn} \cdot V_{Rh}} ;$$

- where DF = decontamination factor
- ZR_{Rh} = net count rate of an iodine sampler for unfiltered air (cpm)
- ZR_{Rn} = net count rate of an iodine sampler for filtered air (cpm)
- V_{Rh} = partial stream through an iodine sampler for unfiltered air (m^3/h).

The penetration D of the iodine sorption filter is calculated from the mean decontamination factor according to

$$D = \frac{100}{DF} ;$$

IV. 4. Safety Assessment, Preliminary Test

If major leaks occur, the radioactivity of the test agent used could contaminate the environment. For this reason, a preliminary test is carried out with lower radioactivity (≤ 1 mCi) of the test agent. The radioactivity trapped in an iodine sampler for the filtered air during the preliminary test is measured with a portable, battery operated single channel analyzer or by means of a shielded NaI(Tl) scintillation detector and multichannel analyzer. The lower limit of detection in the preliminary test is fixed at 1 % penetration of the radioactivity fed in. Since optical inspection and measurement of the pressure drop across the iodine sorption filters will safely exclude any leak that would result in a penetration of >10 %, the release of ^{131}I activities through the stack in the course of a preliminary test cannot exceed 10 % of a maximum of 1 mCi. In the case of a penetration that high there would be no main test.

If the preliminary test did not reveal any measurable radioactivity on the filtered air side, that is to say, if the penetration was proved to be $< 1\%$, the main test is carried out in which, under the most adverse assumptions, a maximum of 1% of the radioactivity loaded can pass through the iodine sorption filter. If 5 mCi are used for the main test, this is ≤ 0.05 mCi. In the very improbable case of the penetration of the iodine sorption filter precisely corresponding to the limit of detection of the preliminary test, a total of 0.15 mCi resulting from the preliminary test and the main test would be discharged through the exhaust stack. Since methyl iodide is practically not adsorbed on grass, a relatively low dose ingestion factor for ^{131}I can be applied to calculate the environmental exposure. In the case of stack release it appears that the maximum dose equivalent to the thyroid of a man at the point of impact would be on the order of μrem or even lower under the most adverse assumptions with respect to the in-place test. An estimate of the maximum environmental burden taking into account the short term meteorological distribution factor and the inhalation and ingestion doses is carried out before any in-place test and is made available to the supervisory authorities.

For valuable discussions and for correcting the manuscript of this report I should like to thank Dr. Deuber.

