

COMMISSION OF THE EUROPEAN COMMUNITIES

MINES SAFETY COMMISSION

## THIRD REPORT

on

specifications and testing conditions relating  
to fire-resistant fluids used for power transmission



Luxembourg, 10th October 1967

(This Report cancels the second Report dated 16th October 1964)



**COMMISSION OF THE EUROPEAN COMMUNITIES**

**MINES SAFETY COMMISSION**

## **THIRD REPORT**

on

specifications and testing conditions relating  
to fire-resistant fluids used for power transmission



**Luxembourg, 10th October 1967**

**(This Report cancels the second Report dated 16th October 1964)**



## C O N T E N T S

	<u>Page</u>
<b>PREFACE TO THE THIRD REPORT</b>	<b>5</b>
<b>PREFACE TO THE SECOND REPORT</b>	<b>7</b>
<b><u>INTRODUCTION TO THE SECOND REPORT</u></b>	<b>9</b>
<b><u>PART I - GENERAL REMARKS</u></b>	<b>11</b>
- Classification	13
- Flammability criteria	13
- Health criteria	14
- Technical criteria	14
<b><u>PART II - SPECIFICATIONS AND TEST CONDITIONS</u></b>	<b>17</b>
- Conditions of approval	19
- Description, classification and operating temperatures	19
- Specifications and test conditions	20
- Flammability criteria	20
- Health criteria	21
- Technical criteria	21
- Tolerances in the determination of individual characteristics	24
- List of analysis methods	26
- Test during practical operations	27
- Withdrawal of approval	27
<b><u>PART III - DESCRIPTION OF TEST PROCEDURES</u></b>	<b>29</b>
- Determination of ignitability of fluid atomized under pressure (Annex I)	31
- Flame-propagation test in a mixture of the fluid with coal-dust (Annex II)	39
- Draft of an auto-ignition test (Annex III)	47
- Determination of flow temperature (Annex IV)	55
- Determination of kinematic viscosity (Annex V)	63
- Determination of vapour pressure (Annex VI)	69
- Determination of pH value (Annex VII)	77
- Determination of shear strength (Annex VIII)	79
- Determination of anti-corrosion action (Annex IX)	83
- Determination of the resistance to ageing of fluids containing no water (Annex X (A))	85
- Determination of the resistance to ageing of water-containing fluids (Annex X (B))	93
- Determination of the resistance to swelling of packings and seals (Annex XI)	101
- Determination of protection against wear (Annex XII)	103

	<u>Page</u>
- Determination of tendency to foam formation (Annex XIII)	113
- Determination of emulsion stability (Annex XIV)	117
- Determination of toxicity of fire-resistant hydraulic fluids miscible with water, groups A and C (Annex XVII)	119
- Determination of toxicity of fire-resistant hydraulic fluids not miscible with water, group D (Annex XVIII)	123

A P P E N D I X

MEMBERS of the Group of Experts

129

## PREFACE TO THE THIRD REPORT

Having been finally adopted by the Mines Safety Commission on 16 October 1964, the Second Report on specifications and testing conditions relating to fire-resistant fluids used for power transmission was issued to the mining authorities and collieries, and also to oil and chemical firms and to manufacturers of mining machinery, in Community and selected non-Community countries.

The Commission then instructed the Working Party responsible to devote itself in particular to the following points :

### 1. Adjustment of the criteria to advances in technology

After the specifications and testing conditions set forth in the Second Report had been applied in practice for a time, some of them should be reviewed to allow for technological progress achieved meantime.

### 2. Comparison of test results

If, even though the testing conditions have been meticulously adhered to, there are still differences of opinion as to the merits of a particular fluid - if for instance it is authorized in one country and banned in another - the research centres should examine the reasons for these different results.

The extent to which the Second Report's recommendations have been followed has in fact varied a good deal, in the case not only of the member countries' mining authorities but also of the manufacturers of the fluids and of the machinery in which they are used. So far, official regulations making the employment of the Report's specifications and conditions obligatory have been promulgated in only a few countries; in others the authorities have provisionally recommended collieries to use only such fire-resistant fluids as are in line with the Report's specifications.

Now, nearly three years after the Report appeared, it is clear that the requirements laid down in it have been of considerable value in influencing developments with respect to fire-resistant fluids and the machinery for which they are needed.

Thus there are a number of Group A, C and D fire-resistant fluids which do correspond to the Report's specifications, and several manufacturers have made

changes in the design of their machines to allow for the technological characteristics of such fluids.

Moreover, it is becoming evident that the collieries' experience is being turned to account in other industries, with the necessary adaptations for their own particular purposes.

In the meantime, the conclusions drawn from the practical implementation of the Report have enabled a number of improvements to be made, which are taken into account in the present edition.

Fuller data have also recently been secured concerning the importance of anti-corrosion and anti-wear properties, but the findings are not yet sufficiently detailed and conclusive to serve as a basis for recasting the testing conditions. Particulars of progress to date in this connection can be obtained from the specialized research establishments listed in the present volume (1).

I hope very much that the new Third Report will play its due part in raising safety standards in the mines, and on behalf of the Mines Safety Commission I extend sincere thanks to all those who assisted in the studies and in the preparation of the final document.

Luxembourg, 10 October 1967

A. COPPÉ,  
Chairman of the Mines Safety Commission,  
Member of the Commission of  
the European Communities

---

(1) See p. 19.



P R E F A C E  
to the Second Report

The present report on Specifications and Testing Conditions relating to fire-resistant fluids used for power transmission does not represent only the efforts - continued over a period of six years - of a group of specialists (engineers and medical experts) who are daily occupied with these problems in the coalmining industry and in its research stations; it is also the fruit of the continuous collaboration between numerous experts from the oil and chemical industries (manufacturers of these substances), from the coalmining industry (the users) and the machinery manufacturers (who make the machines for which these fluids are intended).

The objective was an ambitious one: namely to ensure that the underground use of fire-resistant fluids for power transmission should be subject, in all Community countries, to the production of a certificate witnessing that they had been examined by means of the same series of tests.

It was consequently not enough simply to lay down criteria of non-flammability. Other criteria had to be laid down, as a guarantee that the liquids do possess the technical characteristics called for by the use for which they are intended, and finally, other criteria again ensuring that these two requirements are met without attendant risk to the health of the workers.

In addition, it was necessary to describe precisely the methods to be used for determining that the fluids proposed for underground use do indeed fulfil the requirements laid down.

It is this which explains the meticulous detail in which the report has been prepared.

Adopting this report at its Plenary Session of October 16, 1964, the Mines Safety Commission gave expression to its conviction that it is a piece of work which can contribute greatly to the furtherance of safety in mines, and hoped that it would be widely distributed.

In the name of the Mines Safety Commission, I thank all the experts who participated in the preparation of this report.

Luxembourg, October 16, 1964

Paul FINET  
Member of the High Authority,  
Chairman of the Mines Safety  
Commission

I N T R O D U C T I O N  
to the Second Report

The Conference of Safety in Coal Mines summoned on September 6, 1956 by the Council of Ministers at the request of the High Authority of the E.C.S.C., immediately after the Marcinelle disaster, adopted the following recommendation in its final report, Chapter II, "Technical Research", in Recommendation 36 - M (page 150 of the Conference Report):

"Research should be continued with the object of developing incombustible fluids to be used in place of inflammable oils for mechanical purposes, e.g., in hydraulic equipment, couplings, tub-decking plant, props, etc."

The Mines Safety Commission which was set up as a result of this Conference and at the suggestion of the High Authority, by the decision of the Council of Ministers on July 9, 1957, with a view to reducing the dangers attendant on the use of combustible fluids in the coal industry, instructed its Working Party on Mine Fires and Underground Combustion to work out the criteria for fire-resistant fluids and for the appropriate tests.

On November 23, 1958, the Working Party decided in the light of the exigencies of safety in mines to entrust the study of this problem to a Committee of Experts.

On December 20, 1960, the Working Party were able to submit to the Mines Safety Commission an information report (published on November 28, 1960) regarding the first conclusions which the Committee of Experts had reached since the beginning of its work.

Having examined this report, the Mines Safety Commission agreed to make it available to all interested bodies for their information, in order to keep them in touch with developments in this field and with work in progress in the Committee of Experts.

In the circular of February 24, 1961 (Doc. 1159/1/61) this information report on the establishment of criteria for fire-resistant fluids used for power transmission and for tests to be carried out was made available to representatives of the coal mining industry, the oil and chemical industries and the mechanical engineering industry in the Community countries. In addition, the text of this report was included in the 2nd Report of the Mines Safety Commission published in June 1961.

Since then the Committee of Experts has re-studied more closely the problems relating to the definition of technical criteria of inflammability and the technological criteria. Comparative tests, carried out in the laboratories of the Technischer Ueberwachungsverein (Essen), at the Versuchsgrubengesellschaft (Dortmund), at the Institut National des Mines (Pâturages) and at the Houillères du Nord et du Pas-de-Calais (Sin-le-Noble), have made it possible to verify the proposed criteria and to test new experimental apparatus and methods. The Committee of Experts has carefully examined the proposals and suggestions submitted by representatives of the industries consulted. In particular, it has had discussions regarding the solution of various questions with representatives of the oil industry, the chemical industry and the mechanical engineering industry, as also the coal mining industry. It has also sought to take full account of the most recent American information in this field.

Examination of the health criteria received its particular attention. The Committee of Experts was able to call upon the advice of medical experts from the Federal Republic of Germany, France and Belgium.

The Committee of Experts is of the opinion that this 2nd report, which contains the most recent information relating to the definition of criteria for fire-resistant fluids used for power-transmission, provides in its present form information which will be useful not only to the coal mining industry but to the above-mentioned industries as well.

It hopes hereby to have contributed towards increasing mine safety.

However, it does not consider that its task is complete. At a suitable time this 2nd report should be re-examined with a view to revising it in the light of the latest technical developments. In this connection, it hopes to be able to take advantage, in the future as in the past, of suggestions and proposals of practical value.

The Committee of Experts wishes to thank all those who have assisted in drawing up its report.

x  
x x

(An appendix to this report gives a list of names of members of the Group of Experts.)

**PART I - GENERAL REMARKS**



## 1. CLASSIFICATION

Available fire-resistant fluids used for power transmission can be divided into the following categories in respect of their utilization:

- A - Emulsions of the oil-in-water type containing a maximum of 20 % combustible matter. Temperatures of use between + 5° and 65° C.
- B - Emulsions of the oil-in-water type containing a maximum of 60 % combustible matter. Temperatures of use between + 5° and 65° C.
- C - Aqueous solutions containing a minimum of 40 % water. Temperatures of use between - 20° and + 65° C.
- D - Fluids containing no water. Temperatures of use between - 20° and + 150° C.

## 2. FLAMMABILITY CRITERIA

The flammability of the fluids is determined by tests a) and b); the result of test c) does not constitute a criterium for rejection, and it is used at present only for research purposes.

### a) Determination of ignitability of fluid atomized under pressure

The fluid to be tested is atomized under a pressure of 70 kg/cm<sup>2</sup>; an oxy-acetylene flame of precisely defined characteristics is then directed on to the jet.

Operating conditions are described in Annex I.

### b) Determination of flame propagation in a mixture of the fluid with coal dust

By this test the propagation of a flame is measured on a mixture of 75 % by vol. of coal dust and 25 % by vol. of fluid, a test piece 250 mm long, 20 mm broad and 2 mm thick being held in a Bunsen-burner flame of 1,000° C temperature to heat the extreme end of the test piece.

Test conditions are described in Annex II.

### c) Determination of auto-ignition

Hydraulic couplings are protected against overloads by a fusible plug, which melts at approximately 140° C. When a fusible plug melts, the pressure of the fluid generally produces a ragged outlet orifice which favours oxidation of the jet accompanied by the formation of peroxides. If the fluid used is flammable, the peroxides undergo auto-ignition at 120° C. Hydraulic couplings can therefore constitute a potential source of fire. This danger is the greater, the smaller the diameter of the fusible plug. A diameter of as little as 10 mm is already large enough to reduce the risk. A device has been developed which makes it possible to test whether the fluid used in the coupling can ignite under the conditions which may arise when a fusible plug melts in unfavourable conditions.

The present draft test procedures and the layout of the apparatus are described in Annex III.

### 3. HEALTH CRITERIA

Fire-resistant fluids must be covered by a toxicological test report.

The report must contain data obtained from animal experiments on: acute toxicity, tendency to irritate the skin and the mucous membranes and toxic effects of the aerosols and products of thermal decomposition.

The execution of this test and the subsequent presentation for approval are described in Annexes XVII and XVIII.

Although the prime purpose of the medical investigation is the determination of toxic irritant effects, no final clearance can be granted to the substance tested; since it is impossible, on the basis of data from the animal experiments, to exclude the possibility of the initiation of allergic dermatoses, the occurrence of acne-type skin changes or other toxic effects. As a rule, such deleterious effects occur only after a fairly long period of contact between irritant and subject. Consequently, even if the mining health criteria are fulfilled, a hydraulic fluid can be cleared only for a given introductory period; only after this practical test can a decision be reached as to a final clearance.

### 4. TECHNICAL CRITERIA

#### a) Determination of flow temperature

The flow temperature at which the product again reaches a certain degree of fluidity, once it has passed from the solid state, must lie sufficiently below the lower temperature at the place of use. The flow temperature is determined in accordance with the French Standard NFT 60-122 of June 1956.

The device used and the method of operation are described in Annex IV.

#### b) Determination of viscosity

The fire-resistant fluids must be capable of being pumped in devices with hydraulic control at surrounding temperatures which vary, according to the place of use, between - 20° C and + 50° C. The viscosity must be measured in accordance with the table on the following page.

The viscosity is determined by means of a viscosimeter and the appropriate thermostats, which are described in Annex V.



Data for viscosity measurements

Temperatures	- 20° C	0° C	+ 20° C	+ 50° C	+ 100° C
Groups	-	-	A	A	-
	-	-	B	B	-
	C	C	C	C	-
	D	D	D	D	D

c) Determination of vapour pressure

The fire-resistant fluids free from water for use in hydraulic couplings must not exhibit at a temperature of 200° C a higher vapour pressure than that of normal mineral oils at 140° C.

Fluids containing water are not at present being subjected to this test.

The vapour pressure should be determined by means of the vapour-pressure device described in Annex VI.

d) Determination of pH value

The pH value of fire-resistant fluids of groups A and C serves as an index of the danger arising on contact with the skin. For fluids of groups B and D, the neutralization index must be determined.

The measurement of the pH value must be carried out by the method described in Annex VII. The neutralization index must be determined by conventional methods (e.g., ASTM).

e) Determination of shear strength

The determination of shear strength, as an index of resistance to mechanical stresses, is indispensable for fluids intended for hydraulic transmissions, with the exception of group A fluids, which have a viscosity of less than 10 centistokes at 20° C.

The measurement must be carried out by the method described in Annex VIII.

f) Determination of the anti-corrosion action

The anti-corrosion action of the fire-resistant fluids is to be determined by the method described in Annex IX for those metals and alloys used in the construction of mining equipment which may contain the fluids listed above, particularly: steel, cadmium-plated copper, zinc, aluminium, brass (70/30).

g) Determination of the ageing of fluids

The methods for determining the resistance to ageing of

- a) fluids containing no water (Group D) are described in Annex X (A)
- b) water-containing fluids (Groups A, B and C) in Annex X (B).

In determining ageing, the test is carried out at 95° C in the presence of copper and iron as catalysts, oxygen being led into the fluid continuously.

#### h) Determination of the behaviour of packings and seals

In order to avoid losses of fire-resistant fluids through packings and seals, changes in the packing or seal material should be as small as possible. The method is to be applied to all fluids at 70° C, and additionally at 150° C for fluids of group D.

The method for determining swelling of packings and seals, and variations in the Shore hardness, is described in Annex XI.

#### i) Determination of protection against wear

It is necessary to avoid abnormal wear of the material. Protection against wear is determined with the 4-ball machine, applying the method of progressive loading.

The method of determination is described in Annex XII.

#### k) Determination of tendency to foam formation

Fire-resistant fluids should have the lowest possible tendency to form foam. The method of determination is described in Annex XIII.

#### l) Determination of emulsion stability

Emulsion stability is determined only for groups A and B. It is determined by the method described in Annex XIV.

#### m) Miscibility and compatibility

For economic reasons it should be possible:

- a) to mix, on the basis of miscibility, fresh, unused products of similar composition but of different origin, especially for groups C and D;
- b) to mix, on the basis of compatibility, a new product with a similar product of the same group which has already been in use, but is of different origin.

No method of testing for fulfilment of these requirements was available at the time of publication of the present report.

#### n) Determination of water content

At the time of publication of the present report, no method could be laid down.

#### o) Determination of surface tension

The surface tension of the fire-resistant fluids should be of the same order of magnitude as that of mineral oils.

The determination is to be carried out in accordance with standard ASTM D 977.50 T or AFNOR - T. 73.060.

**PART II - SPECIFICATIONS AND TEST CONDITIONS**



GENERAL REMARKS

Article 1 - Conditions of approval

1) Fire-resistant fluids for hydraulic power transmission and hydraulic control, before being used in mine workings, must be given a certificate of approval indicating that they have passed the following series of tests:

- a) laboratory tests, described below  
(Articles 3 to 7 inclusive and Part III of the report)
- b) long-duration tests in normal use (Article 8)

2) The series of tests is placed under the control of a competent authority. At present the organizations authorised as such are as follows:

<u>Germany</u>	<ul style="list-style-type: none"> <li>- Technischer Ueberwachungsverein, Essen/Ruhr (Senior specialist institute)</li> <li>- Versuchsgrubengesellschaft m.b.H., Dortmund</li> <li>- Hygiene-Institut des Ruhrgebiets, Gelsenkirchen</li> <li>- Pharmakologisches Institut der Universität Hamburg, Hamburg</li> </ul>
<u>Belgium</u>	<ul style="list-style-type: none"> <li>- Institut National des Mines, Pâturages/Hainaut</li> </ul>
<u>France</u>	<ul style="list-style-type: none"> <li>- Laboratoire des Lubrifiants des Houillères du Bassin du Nord/Pas-de-Calais, Sin-le-Noble (Nord)</li> </ul>
<u>Luxembourg</u>	-
<u>Italy</u>	-
<u>Holland</u>	<ul style="list-style-type: none"> <li>- Centraal Laboratorium van de Staatsmijnen, Geleen</li> </ul>

3) Approval of the use of these fluids in mine working is dependent on production of the certificate mentioned in para. 1).

Article 2 - Description, classification and operating temperatures

1) Fire-resistant fluids for hydraulic power transmission and hydraulic control are labelled by the initials HS (Hydraulikflüssigkeit, schwer entflammbar):

German Federal Republic .....	HS
Belgium .....	T H I
France .....	T H I
Luxembourg .....	T H I
Italy .....	
Holland .....	

- 2) Four ranges of viscosities have been provisionally laid down, covering the entire range of possible applications:

HS 1 .....	1 to 1.5 Centistokes	at + 50° C
HS 2 .....	11 to 14	" at + 50° C
HS 4 .....	20 to 40	" at + 50° C
HS 8 .....	50 to 70	" at + 50° C

- 3) The categories of fire-resistant fluids at present available can be classified on the basis of their use in the following groups:

- A - Emulsions of the oil-in-water type, containing a maximum of 20 % combustible matter.  
Temperatures of use between + 5° and + 65° C.
- B - Emulsions of the water-in-oil type, containing a maximum of 60 % combustible matter.  
Temperatures of use between + 5° and + 65° C.
- C - Aqueous solutions containing a minimum of 40 % water.  
Temperatures of use between - 20° and + 65° C.
- D - Fluids containing no water.  
Temperatures of use between - 20° and + 150° C.

- 4) The full marking of a fire-resistant fluid for hydraulic power transmission and hydraulic control will therefore be one of the following:

HS 1-A,  
HS 2-A, HS 2-C, HS 2-D,  
HS 4-B, HS 4-C, HS 4-D,  
HS 8-B, HS 8-C, HS 8-D.

- 5) Fluids in groups B, C and D are examined as delivered. Group A fluids are examined after dilution according to the manufacturer's instructions.

#### SPECIFICATIONS AND TEST CONDITIONS

Articles 3 to 6 show the results which should be obtained in the laboratory tests described in the next article 7 and in Part III of the report.

#### Article 3 - Flammability criteria

- 1) Ignitability of fluid atomized under pressure (Annex I)

The fluids must be given the rating "1" or "2" noted in paragraph 4 on page 32, in five consecutive tests.

Rating "2" may also be given if individual flame peaks reach the screen when the burner is 1.20 m from the spraynozzle.

- 2) Flame propagation in a mixture of the fluid with coal dust (Annex II)

The flame should not spread markedly beyond the zone of effect of the Bunsen-burner flame. The average over five measurements must not exceed 7 cm, measured from the extreme end of the test piece.

Two series of tests are carried out on each fluid, one on the fresh, unused fluid, the other on the fluid recovered after the shearing test.

### 3) Auto-ignition (Annex III)

No ignition should take place when the fluid under test is forced out. This test applies only to group D fluids, especially those to be used in hydraulic couplings or installations working at high temperature (above 120° C).

It must be considered solely as a research test procedure at present.

### Article 4 - Health criteria

- 1) a) The toxicity tests applied to water-containing substances are carried out according to the techniques described in Annex XVII. Substances containing no water are examined in accordance with the techniques described in Annex XVIII.
- b) Substances given a rating of 10 in individual tests or a rating of 50 in a test series should be rejected.
- 2) The Toxicological Institute charged with performing the tests can communicate direct with the suppliers of the hydraulic fluids, to facilitate its work.
- 3) The Toxicological Institute charged with the performing of the tests is the sole institute responsible for assessing the test results. Its findings are to be transmitted to the senior specialist institute. The suppliers of the fluid may request a copy of the findings from the senior specialist institute.

### Article 5 - Technical criteria

#### 1) Flow temperature (Annex IV and standard AFNOR T 60-122)

The flow temperature is determined before and after the shearing test. The flow temperature of the new fluid serves only for purposes of identification. The permissible limit values for the modification of the flow temperature after the shearing test are shown in Table 2.

#### 2) Viscosities (Annex V)

These must correspond with the figures set out in Table I:

TABLE I

Series	Group	Kinetic viscosity in centistokes at				
		- 20° C	± 0° C	+ 20° C	+ 50° C	+ 100° C
HS 1	A	No determinations				
HS 2	A			/ 50	11/14	
	C	/ 1 800	/ 170	/ 50	11/14	
	D	/ 1 800	/ 170	/ 50	11/14	
HS 4	B			/ 190	20/40	
	C	/ 5 000	/ 800	/ 190	20/40	
	D	/ 5 000	/ 800	/ 190	20/40	7 6
HS 8	B			/ 360	50/70	
	C	/ 12 000	/ 1 800	/ 360	50/70	
	D	/ 12 000	/ 1 800	/ 360	50/70	7 10

The figures shown for - 20° and ± 0° C serve as provisional limit values.

### 3) Vapour pressure (Annex VI)

At the present time this test is restricted to fluids containing no water. The vapour pressure of such a fluid at a temperature of 200° must not exceed that of mineral oils. It must, in any case, be below 0.5 kg/cm<sup>2</sup>.

### 4) pH value (Annex VII)

The pH value must be less than or equal to 10.

This measurement is carried out only on groups A and C fluids. For groups B and D fluids, the neutralization index must be determined.

### 5) Shear strength (Annex VIII)

The characteristics to be determined on the recovered liquid are listed in Table II. The variations from the values given by the same fluid before the shear test must not exceed the limits shown in Table II.

TABLE II

Characteristics measured	Fluid groups tested			
	A (1)	B	C	D
Kinetic viscosities at:				
- 20° C	-	-	/ + 40 %	/ + 15 %
+ 0° C	-	-	+ 40 %	+ 15 %
+ 20° C	/ + 10 %	/ + 10 %	/ + 35 %	/ + 10 %
+ 50° C	/ + 10 %	/ + 10 %	/ + 30 %	/ + 5 %
Flow temperature	/ + 30° C	/ + 30° C	/ + 30° C	/ + 30° C
pH	/ + 0.5	-	/ + 1	-
Neutralization value (mg/KOH/gm)	-	/ + 0.5	-	/ + 0.5
Water content %	/ - 15 %	/ - 5 %	/ - 8 %	-

(1) Excepting fluids HS 1 - A.

### 6) Anti-corrosion action (Annex IX)

There should be no appreciable corrosion of metals or alloys used in the construction of the different machines; the reduction in weight must not exceed 10 mg per sample for metals of specific weight above 7 g/cc and 5 mg per sample for metals of specific weight below 7 g/cc. The same requirement applies to metals used in the preparation of metallic coverings.

In normal circumstances it should not be possible to observe any deposit on the samples; the increase in weight must not exceed 5 mg per sample.

The metal surfaces immersed in the liquid must not show any appreciable change in colour; if the colour does change, the reasons must be investigated. The surfaces not touched by the liquid must not show appreciable colour change or corrosion either.



7) Ageing (Annex X-A and X-B)

Fire-resistant fluids should normally exhibit a resistance to deterioration and oxidation as close as possible to that of petroleum-based lubricants. The permissible variations during the tests are as follows:

a) Fluids of groups B and D. Test duration 600 hours.

Increase in neutralization value  $\leq$  2 mg KOH/gm for groups B and D fluids.

Increase in constituents insoluble in benzene  $\leq$  2 % for group D fluids.

b) Fluids of groups A (excepting fluids HS 1-A) and C. Test duration: 200 hours. After this period the pH should not be  $\leq$  4.

c) The metal spirals should not become fouled or corroded to any marked extent.

8) Behaviour of packings and seals (Annex XI)

No appreciable deterioration must be observable in the material used in packings or seals, in particular there must be no shrinkage, no hardening or modification of the surface (cracks). The maximum permissible variations are:

a) Swelling: 4 % of the volume of the test piece.

b) Shore hardness:  $\pm$  5.

c) Shrinkage: 2 % of the volume of the test piece.

9) Protection against wear (Annex XII)

The minimum values given in Table III are permissible for average Hertz loadings, the value 100 being given to the average Hertz loading for a pure paraffin-based oil, with a viscosity of  $50 \pm 1$  centistokes at  $+ 50^{\circ}$  C, used as a reference fluid.

The minimum values for seizing load are also given in Table III.

TABLE III

	Reference oil	Group			
		A (1)	B	C	D
Average Hertz loading	100 %	85 %	95 %	100 %	100 %
Seizing load	160 kg	90 kg	130 kg	130 kg	150 kg
(1) Excepting fluids HS 1 - A.					

10) Tendency to foam formation (Annex XIII)

Fire-resistant fluids must not form a greater volume of foam than that occurring with petroleum products.

11) Emulsion stability (Annex XIV)

This test is carried out only on groups A and B. The following limit values must be observed:

a) Group A - Occurrence of creamy foam  $\leq$  5 mm after 1000 hours at  $+ 20^{\circ}$  C or at  $+ 40^{\circ}$  C.

b) Group B - Occurrence of creamy foam  $\leq$  5 mm after 600 hours at + 20° C or at + 40° C.

c) Separation of water and oil is not allowed.

12) Miscibility and compatibility (Annex XV, not finished at the time of publication)

Basically, fire-resistant fluids of the groups C and D should be mutually miscible in the fresh, unused state. Furthermore there should be compatibility within groups A, B, C and D, between a used fluid and newly-added fresh fluid of the same group.

13) Water content (Annex XVI, not finished at the time of publication)

For the moment, this test is envisaged only for checking purposes.

14) Density (standard method)

The density is used for purposes of identification. It should as far as possible be below 1.5.

15) Ash content (standard method)

Ash content is used for identification purposes. The following values should not be exceeded:

Group A .....	4 %,	determined on the concentrated flammable product;
Group B .....	1.5 %,	determined on the fluid as ready for use;
Groups C and D .....	2 %,	determined on the fluid as ready for use.

16) Surface tension (standard method)

The figure for surface tension must not exceed 38 dynes/cm at 20° C.

Article 6 - Tolerances in the determination of individual characteristics

Methods:

M 1 - Annex I	- <u>Spray ignition over a flame:</u> no tolerances.
M 2 - Annex II	- <u>Flame propagation:</u> $\pm$ 5 mm of the propagation path of the flame.
M 3 - Annex III	- <u>Auto-ignition:</u> no tolerances.
M 4 - Annex IV	- <u>Flow temperature:</u> $\pm$ 3° C.
M 5 - Annex V	- <u>Viscosities:</u> $\pm$ 5 %.
M 6 - Annex VI	- <u>Vapour pressure:</u> $\pm$ 10 %.

- M 7 - Annex VII - pH value:  
± 0.1 pH.
- M 8 - Annex VIII - Shear strength:  
the variations in the characteristics are to be taken as "measurement tolerances already deducted".
- M 9 - Annex IX - Anti-corrosion action:  
no tolerances.
- M 10 - Annex X - Ageing:  
the variations in the characteristics are to be taken as "measurement tolerances already deducted".
- M 11 - Annex XI - Behaviour of packings and seals:  
max. ± 25 % of measured value.
- M 12 - Annex XII - Protection against wear:  
± 10 %.
- M 13 - Annex XIII - Foam formation:  
± 25 %.
- M 14 - Annex XIV - Emulsion stability:  
± 50 % of the height of the separated layer.
- M 15 - Annex XV - Miscibility and compatibility:  
no tolerances.
- M 16 - Annex XVI - Water content:  
not yet laid down.
- M 17 - Annex XVII - Ash content:  
± 20 %.
- M 18 - Annex XVIII - Surface tension:  
± 2 dynes/cm.

## Article 7 - List of analysis methods

T e s t s	Method described in annex:	Standards and documents for individual countries				
		Germany	Belgium	France	Netherlands	U.S.A.
3.1. Spray ignition	I					
3.2. Flame propagation	II					
3.3. Auto-ignition	III					
5.1. Flow temperature	IV			T 60-122		
5.2. Viscosity	V	DIN 53015 E				
5.3. Vapour pressure	VI					
5.4. Measurement of pH value	VII					
5.5. Shear strength	VIII					
5.6. Anti-corrosion action	IX					
5.7. Ageing: of fluids containing no water of fluids containing water	X (A)	DIN 51587			NEN 3024	ASTMD 943.54
	X (B)					
5.8. Behaviour of packings and seals	XI	DIN 53521 E				
5.9. Protection against wear	XII					
5.10. Tendency to foam formation	XIII					ASTMD 892.58 T
5.11. Emulsion stability	XIV					
5.12. Miscibility and compatibility	XV (1)					
5.13. Water content	XVI (1)					
5.14. Density		DIN 51757	NBN 52011 52015 and 52044	T 60.101	N. 907	
5.15. Ash content		DIN 51575	NBN 52044	T 60.111	N. 907	
5.16. Surface tension				T 73.060		ASTMD 977.50 T
4.1. Toxicological test: - fluids containing water (A+C) - fluids containing no water (D)	XVII XVIII					
(1) Method not laid down at time of publication, but under consideration.						

**Article 8 - Test during practical operations**

- 1) These tests are carried out in a mine working at the request of the specialist institute, with the authorization of the competent authorities.

The conditions for carrying out the tests shall be agreed between the above-mentioned bodies.

- 2) The supplier of the test fluid shall be allowed to be present at the tests, only if this is agreed beforehand. In such a case, the responsible institute must be informed.
- 3) These tests must be at least 6 months in duration.

**Article 9 - Withdrawal of approval**

At the request of the specialist institute, the permitting authority may withdraw the approval for the fluid to be used in mine workings.

x  
x x



**PART III - DESCRIPTION OF TEST PROCEDURES**





DETERMINATION OF IGNITABILITY OF FLUID ATOMIZED UNDER PRESSURE1. PRINCIPLE

The flame of an oxy-acetylene torch is directed on to an atomized jet of the fluid under test. The effects of the flame on the jet are observed.

2. APPARATUS

- a) A container for the test fluid, with a minimum capacity of 1 litre.  
 b) Pressure device for the spray jet (Scheme A or B on p. -a- following).

SCHEME A: A cylinder of compressed nitrogen with a pressure-reducing valve set to  $70 \pm 3$  kg/sq.cm. This cylinder is linked by a high-pressure hose to a fluid container which can be heated electrically, from which a closeable, heat-insulated pipe leads to the spray nozzle. The temperature of the test fluid can be measured by means of copperconstantan thermo-elements in the tank and immediately in front of the atomising spray nozzle.

SCHEME B: A pressure device, consisting of a pressure pump connected to the spray nozzle via a pipe to which are connected the pressure gauge for checking purposes and a pressure regulator, which forces excess fluid back into the tank.

The pressure regulator is set at  $70 \pm 3$  kg/sq.cm. The spray nozzle is connected directly to a valve.

- c) A test spray nozzle as shown in the drawing (see p. -b- following).

This consists of a hard steel disc with a 0.4 mm diameter discharge orifice in the centre; the edges of this orifice are sharp. The disc must present a smooth surface of 10 mm diameter to the test fluid; the plate with the 0.4 mm orifice is 1.6 mm thick. To ensure maximum security against blockage of the jet, a / 0.4 mm mesh sieve (144 meshes per sq.cm), with a minimum diameter of 10 mm, must be fitted upstream of the jet. The distance between the jet and the sieve should be about 20 mm.

- d) An oxy-acetylene torch which must burn with a 100 mm conical flame, edged with blue, and which meets the requirements set out below (see sketch -c-).

Each of the two gases leaves its container under pressure and passes through a pressure regulator which is generally placed between a high-pressure manometer and a low-pressure manometer, after which it reaches a precision pressure gauge and passes thence into the torch via a flowmeter.

The range of measurement of a precision pressure gauge is from 0 to 10 kg per sq.cm overpressure; the range for the acetylene manometer is 0 to 1.6 kg per sq.cm.

The RHN flowmeters are provided by the Rota Company of Oeflingen (Baden).

The oxy-acetylene welding torch, Rex No. 1 type, manufactured by the Charledave Company of Paris, is fitted with a 750  nozzle.

The pressure regulator and the needle valves of the torch are so adjusted that a quantity of  $13 \pm 1$  litres/minute at  $0^{\circ}$  C and 760 mm Hg of oxygen is discharged and  $15 \pm 1$  litres/minute at  $0^{\circ}$  C and 760 mm Hg of acetylene, at a pressure of 5.0 kg/sq.cm for the oxygen and 1 kg/sq.cm for the acetylene.

So as to avoid frequent readjustment of the gas pressure during a series of trials, it is advisable to install a stopcock between the pressure regulators of the reservoirs which are under pressure and the precision pressure gauges.

- e) A metal screen 75 cm broad and 100 cm high, set up at right angles to the jet at a distance of 170 to 180 cm from the nozzle tip, so that its middle-point falls approximately on the projection line of the spray nozzle.

### 3. TEST PROCEDURE

Once the fluid has reached a temperature of  $65 \pm 5^\circ \text{C}$  and is under a pressure of  $70 \pm 3 \text{ kg/sq.cm}$ , the valve to the spray nozzle is opened. The attempt is then made to ignite the jet of fluid with the oxy-acetylene flame. The flame is moved at a speed of 4 cm/sec, at right angles to the jet of fluid, and along it in such a way that the tip of the cone travels from the nozzle to a point 120 cm away from the nozzle along the axis of the jet of fluid; it is kept stationary for 5 seconds at its greatest distance from the jet. The total duration of the test is 35 seconds. Five tests must be carried out in immediate succession.

Before running a new test with a different fluid, in Scheme A the fluid containers and the separate nozzle components must be rinsed several times with boiling water to which a cleansing agent has been added.

In Scheme B, the test apparatus must be flushed carefully with the fluid under test.

### 4. RECORDING OF TEST RESULTS

The results must be recorded as follows:

- a) the jet of fluid does not ignite = (1)
- b) the jet of fluid ignites, but the flame does not reach the screen = (2)
- c) the jet of fluid ignites, and the flame reaches the screen = (3).

Note: This method is based on the American Method AMS-3150 C. The atomising pressure and the dimensions of the nozzle are the same as in Method AMS-3150 C.

- a -

ANNEX I

DETERMINATION OF IGNITABILITY OF  
FLUID ATOMIZED UNDER PRESSURE

Scheme A

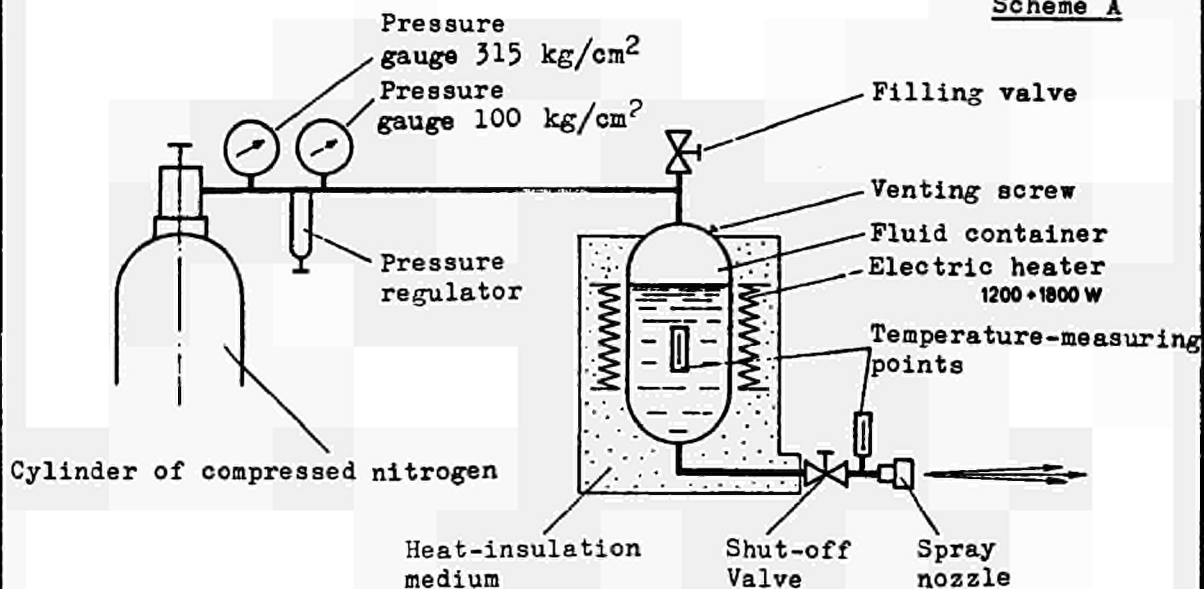

Scheme B

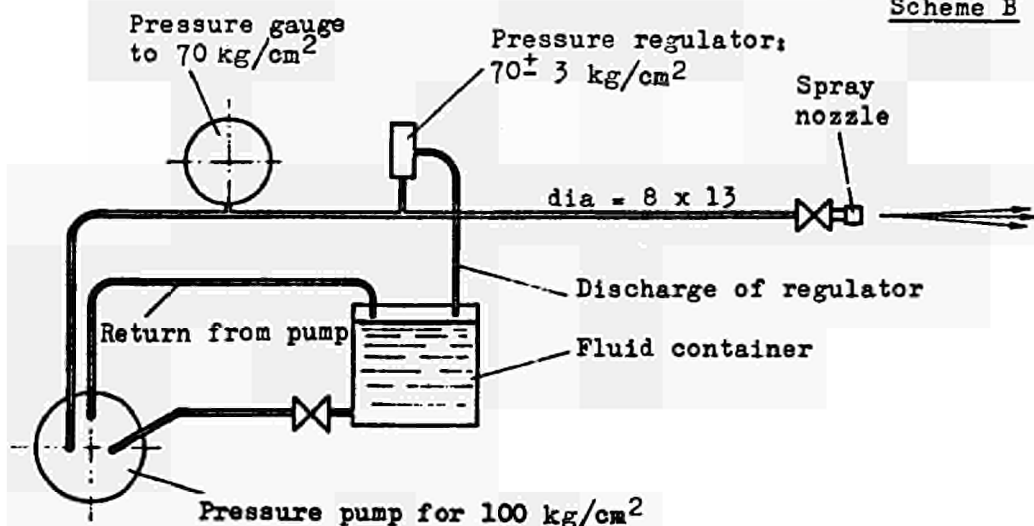



- b -  
 DETERMINATION OF IGNITABILITY OF  
 FLUID ATOMIZED UNDER PRESSURE

ANNEX I

Components of test nozzle

Scale 2:1

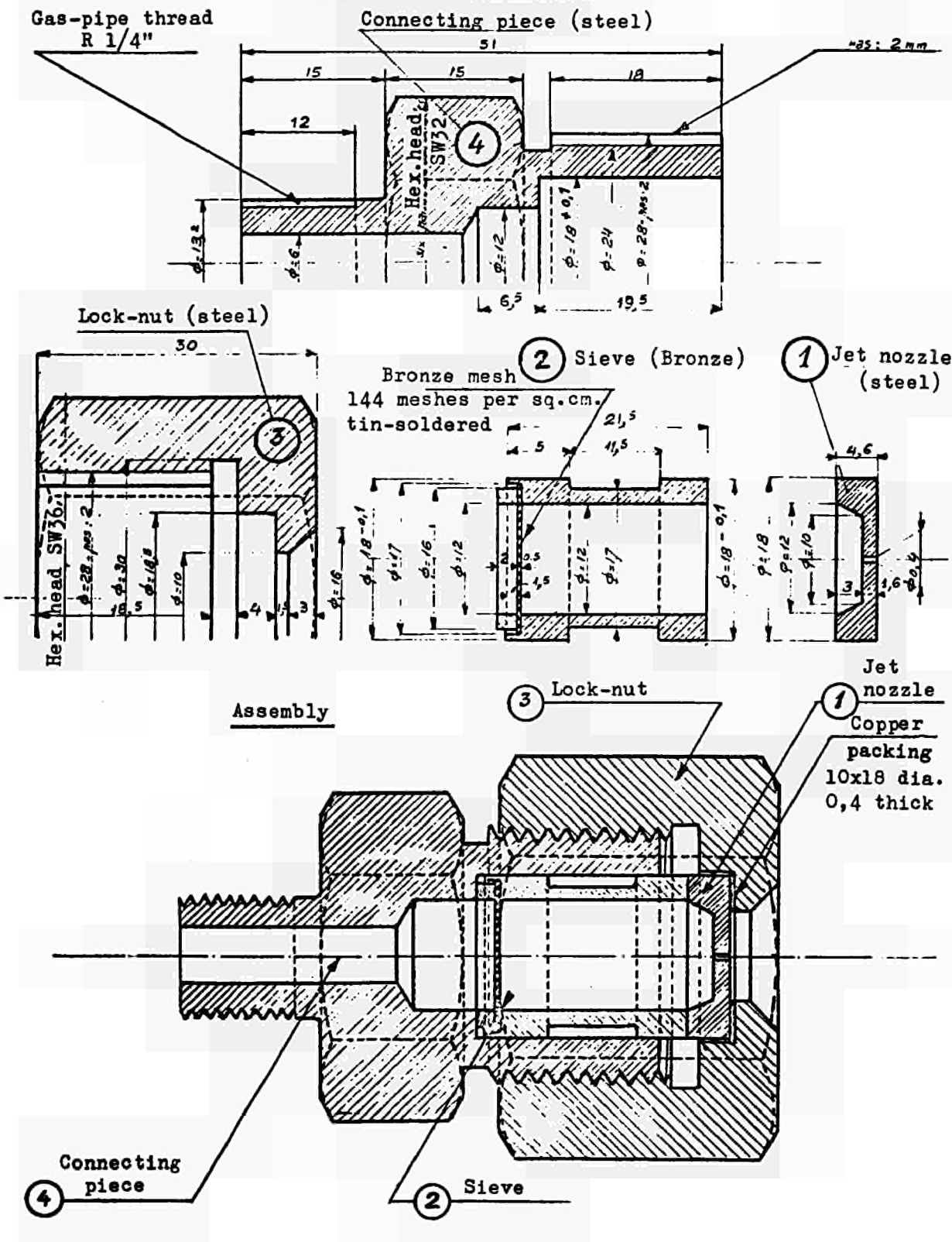



- c -

Annex I

DETERMINATION OF IGNITABILITY OF FLUID  
ATOMIZED UNDER PRESSURE

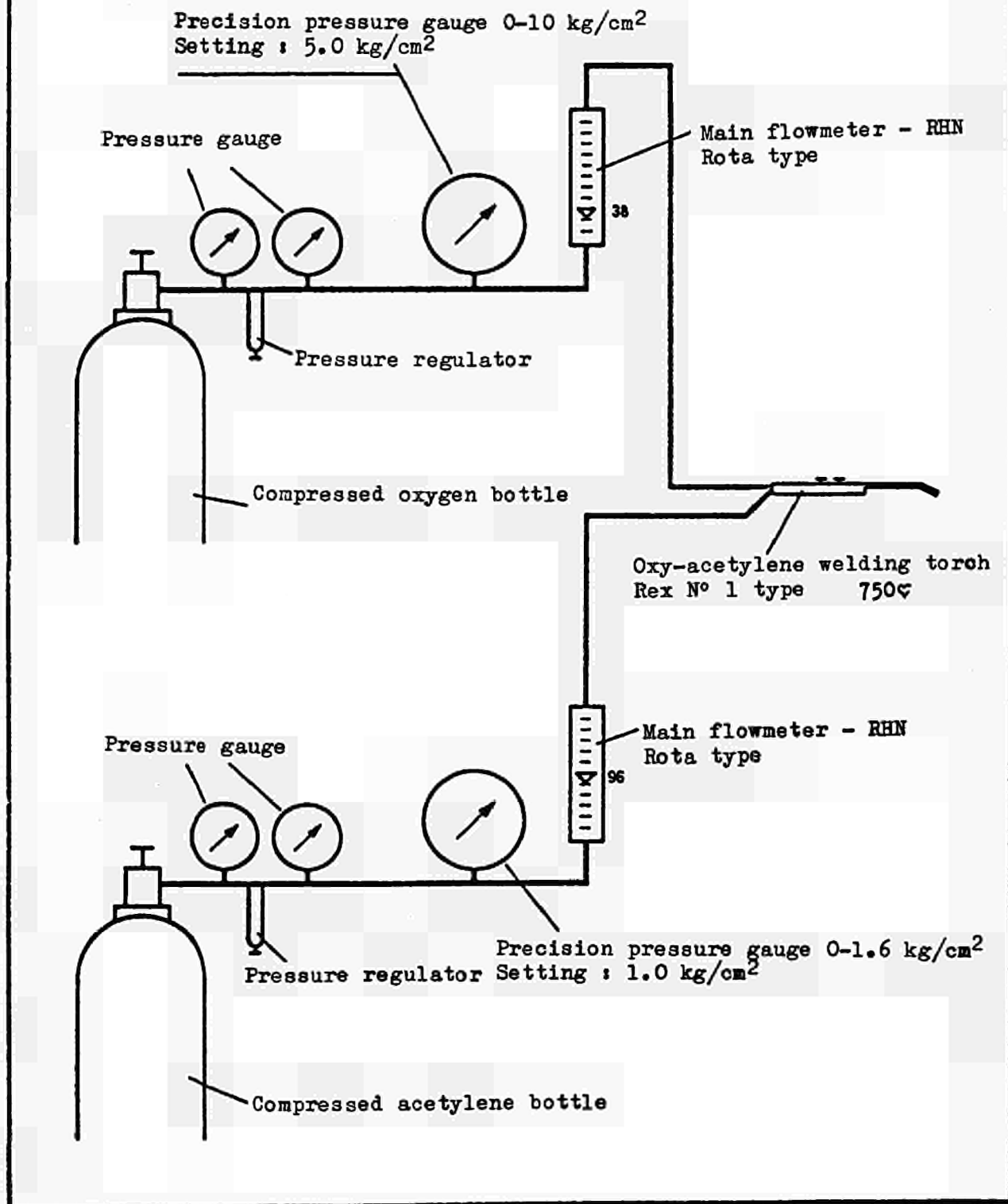





FLAME-PROPAGATION TEST IN A MIXTURE OF THE  
FLUID WITH COAL-DUST

1. PRINCIPLE

The propagation of a flame is measured in a mixture of 75 % by vol. of coal-dust and 25 % by vol. of fluid. The test is carried out in a room at normal air temperature without artificial ventilation.

2. APPARATUS (Assembly and details in attached drawings)

- (1) Adjustable Bunsen burner
- (2) Standard ring with 140 mm mean diameter
- (3) Longitudinal stop plate
- (4) Support for items (2) and (3)
- (5) Steel plates to carry the test pieces
- (6) Thermo-couple and pyrometer
- (7) Graduated scale with adjustable support
- (8) Metal frame for making test pieces
- (9) Slides for making test pieces
- (10) Laboratory stop-watch.

3. MAKING THE TEST PIECES

The test piece must be 250 mm long, 20 mm broad and 2 mm thick. The steel plates (5) have a datum mark, to facilitate keeping the length of the sample piece to 250 mm measured from one end. Correct adjustment of the width is obtained by using the slides (9). The jig for making the test pieces is shown in the attached drawing, which also illustrates the plates and metal frames used.

The test piece consists of a mixture of 75 % by volume of coal dust and 25 % by volume of test fluid. The coal-dust volume is measured in a calibrated cylinder approx. 35 mm in diameter and about 155 mm tall. A sufficient quantity of mixture is prepared (about 150 cc) to provide for at least 5 tests, allowing for handling losses. The mixture is prepared by hand in a mortar.

4. COAL-DUST

The coal-dust used for the tests is drawn from Montrambert coal, prepared by the "Centre d'Etudes et de Recherches des Charbonnages de France" in Verneuil-en-Halette (Oise) and supplied by them. The average characteristics of this dust were as follows:

Moisture .....	1.4 %	tolerance $\pm$ 20 %
Ash (dry basis) .....	10.3 %	tolerance $\pm$ 10 %
Volatile matter (dry basis) .....	27.1 %	tolerance $\pm$ 10 %
Size consist .....	60 to 100 microns.	

### 5. TEST PROCEDURE

The test mixture is prepared as described above, one hour before the beginning of the test; 5 test pieces must be prepared for each substance. Each test piece is attached to a standard ring (2) above a Bunsen burner of a design as per drawing. The longitudinal stop (3) and the stops on the ring hold the test piece accurately in position.

The flame must be adjusted to a free height of approximately 140 mm. The flame temperature, measured some 5 mm below the steel plate (5), should be  $1000^{\circ} \pm 30^{\circ}$  C.

The Bunsen burner is set up in such a way that its axis lies under one end of the test piece (as can be seen in the assembly drawing); the distance between the tip of the flame and the bottom side of the steel plate is 45 mm. A stop-watch is switched on at the moment when the flame is placed under the steel plate. After a heating period of 5 minutes the burner is turned off.

The factors measured are:

- a) the farthest distance covered by the tip of the flame;
- b) the time taken for the flames on the test piece to die out;
- c) the anomalies: glowing after extinction of the flame, renewed ignition, etc.

Each test with a given fluid consists of five measurements, but each test piece is used once only.

### 6. PRESENTATION OF THE RESULTS

The result obtained is expressed as the arithmetic mean of the five measurements according to 5.a). The tolerance between two arithmetic means may not exceed  $\pm$  5 mm for the same operator.

### NOTES

- a) In preparing the test piece care must be taken to press the paste uniformly.
- b) The steel plates for the test piece are scraped clean and cooled before reuse. Any traces of the earlier sample remaining are removed with emery cloth No. 0.
- c) It is advisable to retrace the datum mark on the same steel plate with a metal scriber after every 10 or so tests.

-(a)-

ANNEX II

FLAME PROPAGATION TEST IN A MIXTURE  
OF THE FLUID WITH COAL-DUST

Scale: approx. 1:5

Open flame: approx. 140 mm.

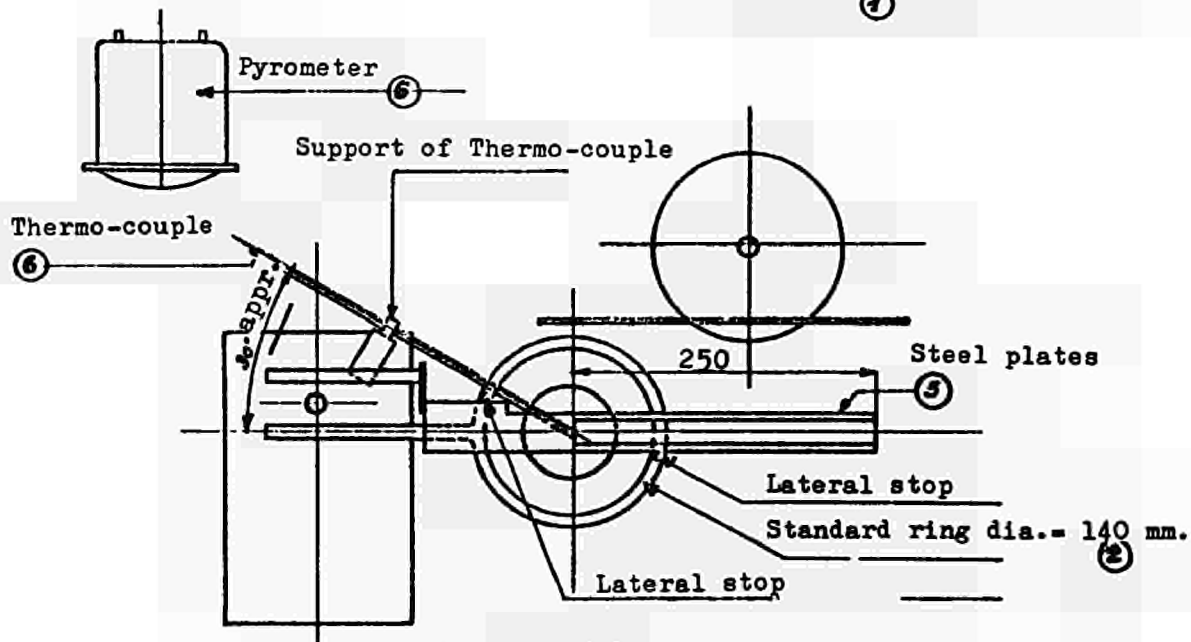
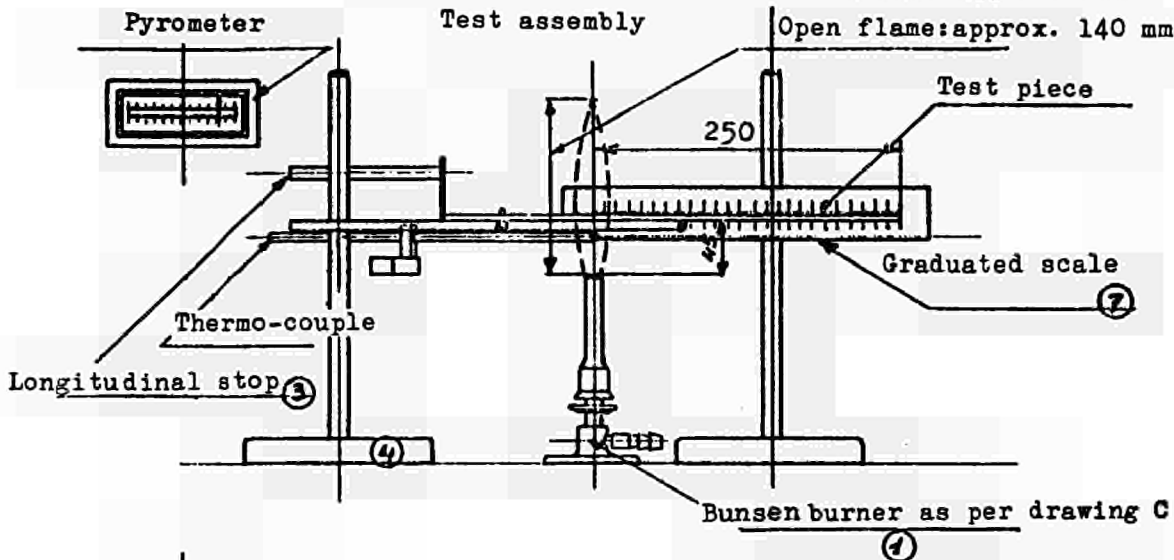

Details of Thermo-couple supports  
and lateral stops

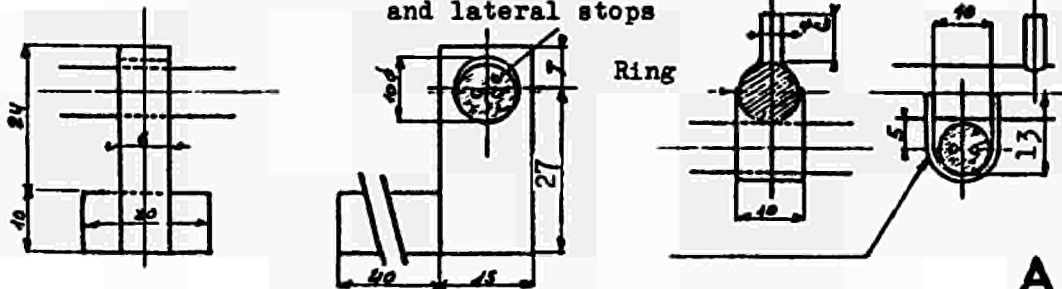

A



-(b)-

ANNEX II

MAKING OF TEST PIECE

Scale: 1:1 and 1:2

Finished test piece



Jig for making test piece

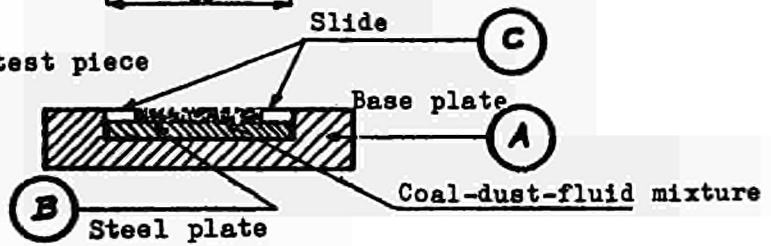

Base plate

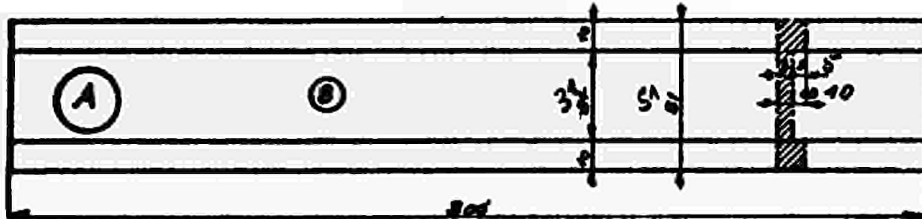

Thickness: 3 mm

Steel plate

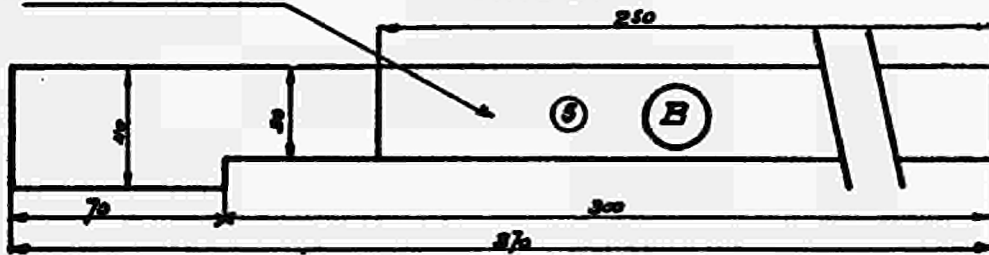

Slide

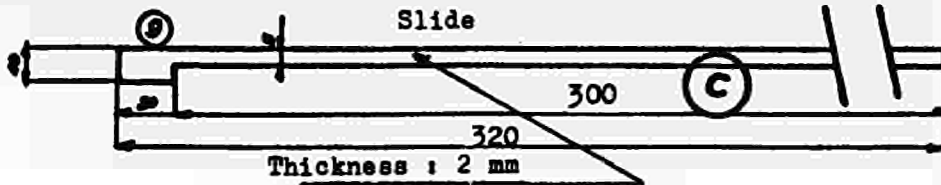

Thickness: 2 mm

B



ANNEX II

BURNER FOR FLAME PROPAGATION TEST APPARATUS

- (c) -

SECTION a

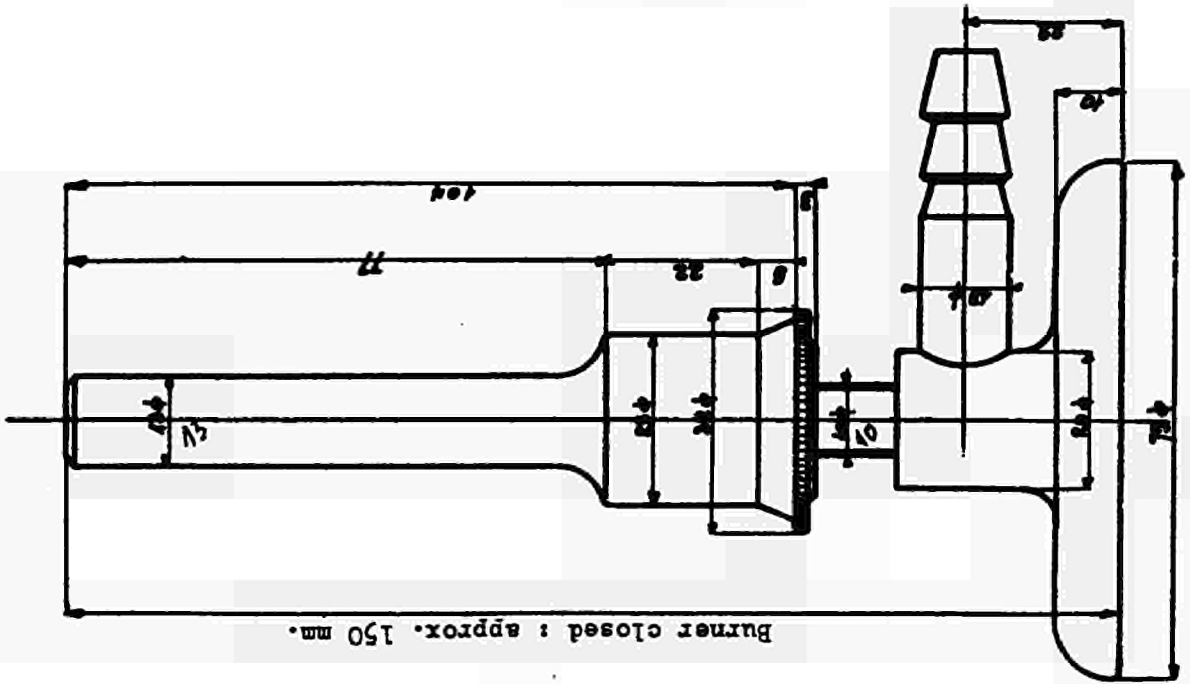
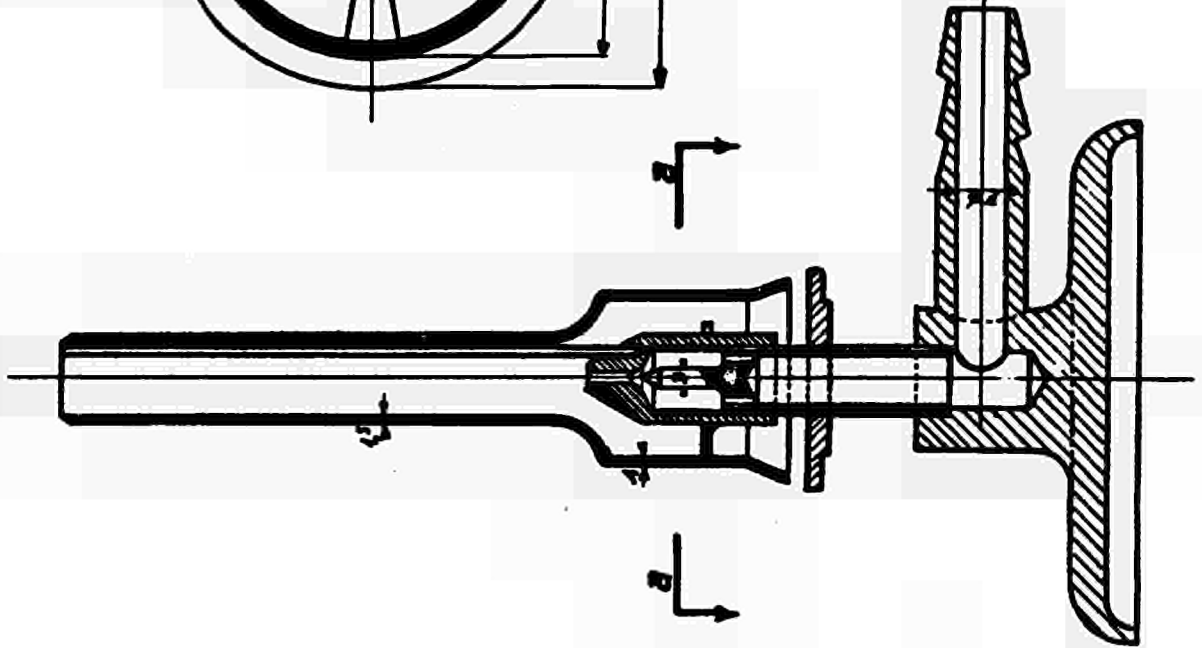
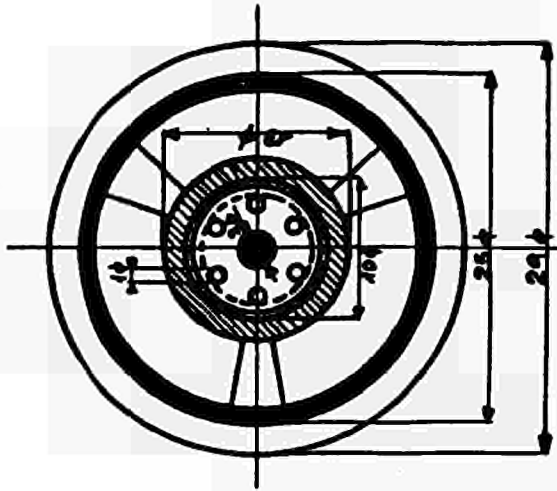

Burner closed : approx. 150 mm.

3





DRAFT OF AN AUTO-IGNITION TEST1. PRINCIPLE

The object of the test is to determine whether a hot hydraulic fluid will undergo auto-ignition on contact with the air, when it is forced under pressure through an orifice in a thin jet, without a flame or a hot plane being present. In this determination the test must be carried out under very carefully determined conditions of temperature and pressure.

The test sets out essentially to simulate the release of energy by the hot fluid when a fusible plug melts. The test is, in principle, carried out only on fluids which do not contain water, but can be applied if necessary to "water-in-oil" emulsions.

2. APPARATUS

The apparatus consists essentially of a heated cylinder containing the fluid to be tested (approximately 250 cc). One end of the cylinder is sealed with a fluid-tight piston, the cavity behind which is filled with a fluid under a pressure of 7 kg/sq.cm. The other end of the cylinder is closed by a fusible plug consisting of an alloy melting at approximately 140°C. The outlet orifice consists of two concentric cones, whose generating lines are parallel and at a maximum of 1 mm apart. The inner cone is held in place by a ring of insulating material pierced by eight holes approximately 1 mm x 6 mm.

By means of an electrical resistance all the surfaces of the cones are brought to the same temperature as the fluid contained in the cylinder. The surface of the outer cone is connected to earth, while the surface of the inner cone is electrically insulated against short circuit.

In addition to the apparatus described above, the test calls for the following devices:

- a device for filling the cylinder with the test fluid;
- an air-discharge vent;
- a pressure regulator with discharge device;
- two pyrometers to measure the temperature of the test fluid and of the outlet;
- the adjustable resistances for the electrical pre-heating devices;
- a device for feeding the fluid under pressure, with a pressure gauge for checking.

The apparatus is shown diagrammatically in the accompanying sketch which also includes a section through the outlet orifice.

3. PREPARATION OF THE FUSIBLE PLUGSa) Composition

The plugs are made of a bismuth-tin alloy containing 60 % by weight of bismuth and 40 % of tin. With cast (not cold-hammered) metal the melting point lies around 140/142°C.

### b) Preparation

Starting with the mixture of powdered metals, strips 16 mm wide and 1 mm thick are cast in the metal mould shown in sketch B; the volume of one such strip is approximately 1.7 cc.

The alloy is cast by placing the filled mould on a heating plate and bringing it up to 180°C. After this casting process the mould is taken off the heating plate to allow the alloy to cool slowly.

### c) Cutting the plugs

This is carried out on the mould and punch shown in sketch B. Six plugs can be cut from one strip.

## 4. PREPARATION FOR THE TEST

### a) Cleaning

The outlet cone is removed and its individual components thoroughly cleaned. The bottom of the cylinder, on which the outlet cone rests, is also removed, to allow of cleaning the cylinder. For this purpose the piston is pushed back as far as the inlet for the fluid under pressure; this is done with the valve closed, unscrewing the drain plug of the pressure-fluid circuit, so that fluid can flow out without any air entering behind the piston.

The air inlet and discharge pipes are rinsed out with carbon tetrachloride. This particular solvent is recommended for this purpose.

### b) Assembly

The drain plug of the pressurized-fluid circuit is carefully screwed home again. The bottom of the cylinder is then pushed towards the outlet cone and the fusible plug refitted. The outlet cone is replaced and fastened; it surrounds the fusible plug and bears on it once it is screwed right home. The resistance heating the cone is then connected up and the two pyrometers replaced in position.

### c) Filling

The air inlet valve is opened first, followed by the filling valve. The inlet valve for the fluid under pressure is closed and the piston pushed right back to allow of filling. The test fluid is then slowly poured in through the funnel, until it begins to flow out through the air-discharge pipe. After this the filling valve is closed, followed by the air-discharge valve. The apparatus is now ready for use. The cylinder has a capacity of approximately 250 cc; allowing for the contents of the piping, the quantity required for the test samples is about 350 cc.

## 5. TEST PROCEDURE

The inlet valve for the fluid under pressure is opened, care being taken to ensure that

- a) the fluid pressure is, in fact, 7 kg/sq.cm,
- b) the pressure regulator does not allow any of the test fluid to pass.

The electrical preheating device for the test cylinder is now switched on, the heater being adjusted to give a temperature rise of roughly 3°C per minute. The neck heater is then switched on and set accurately to the same heating rate. It is a good sign if a small difference of temperature is observed between the neck and the test fluid, since this ensures that the melting of the plug is brought about by the fluid under test; a lag of some 20°C in the pre-heating temperature of the neck is sufficient.

Once the temperature of the fluid under test has reached 120°C, the rate of heating must be reduced to 2°C per minute, to ensure a continuous temperature equilibrium of the whole apparatus. Above 140 to 145°C the entire apparatus must be observed more closely, so that the temperature at which the fluid under test begins to flow out can be recorded.

The jet of fluid must not ignite on contact with the air if the lubricant is to be considered as non-flammable. In the case of mineral oils, ignition will take place at a distance of 0.20 to 0.30 m from the tip of the outlet cone. The ignition is best observed against a black background, so that any possible effects of the production of static electricity as the fluid passes through the outlet cones can be recorded.

As soon as the plug has melted, the current for the electrical pre-heating apparatus is switched off.

Auto-ignition is not absolutely certain to occur (90 % of cases with mineral oil); it is therefore necessary to repeat the test five times.

## 6. REMARKS

### a) Measurement of static electricity produced

If called for, a voltmeter can be connected between the pin supporting the inner cone and the ring of the neck. The terminals are already fitted; the voltmeter must be graduated up to 10 kilovolts.

### b) Fusible alloys

It is possible to use alloys with higher melting-points than that described under 3a; the latter is in fact the alloy used for the manufacture of fusible plugs for hydraulic couplings.

The following table indicates the composition of several simple alloys with melting points between 140 and 183°C.

Melting temperature	Alloy Composition			
	Tin	Lead	Bismuth	Zinc
140/142°	2	-	3	-
144°	3	1	-	-
151°	1	1	-	-
168°	9	2	-	1
183°	1	2	-	-



-(a)-

ANNEX III

DRAFT OF AN AUTO-IGNITION TEST

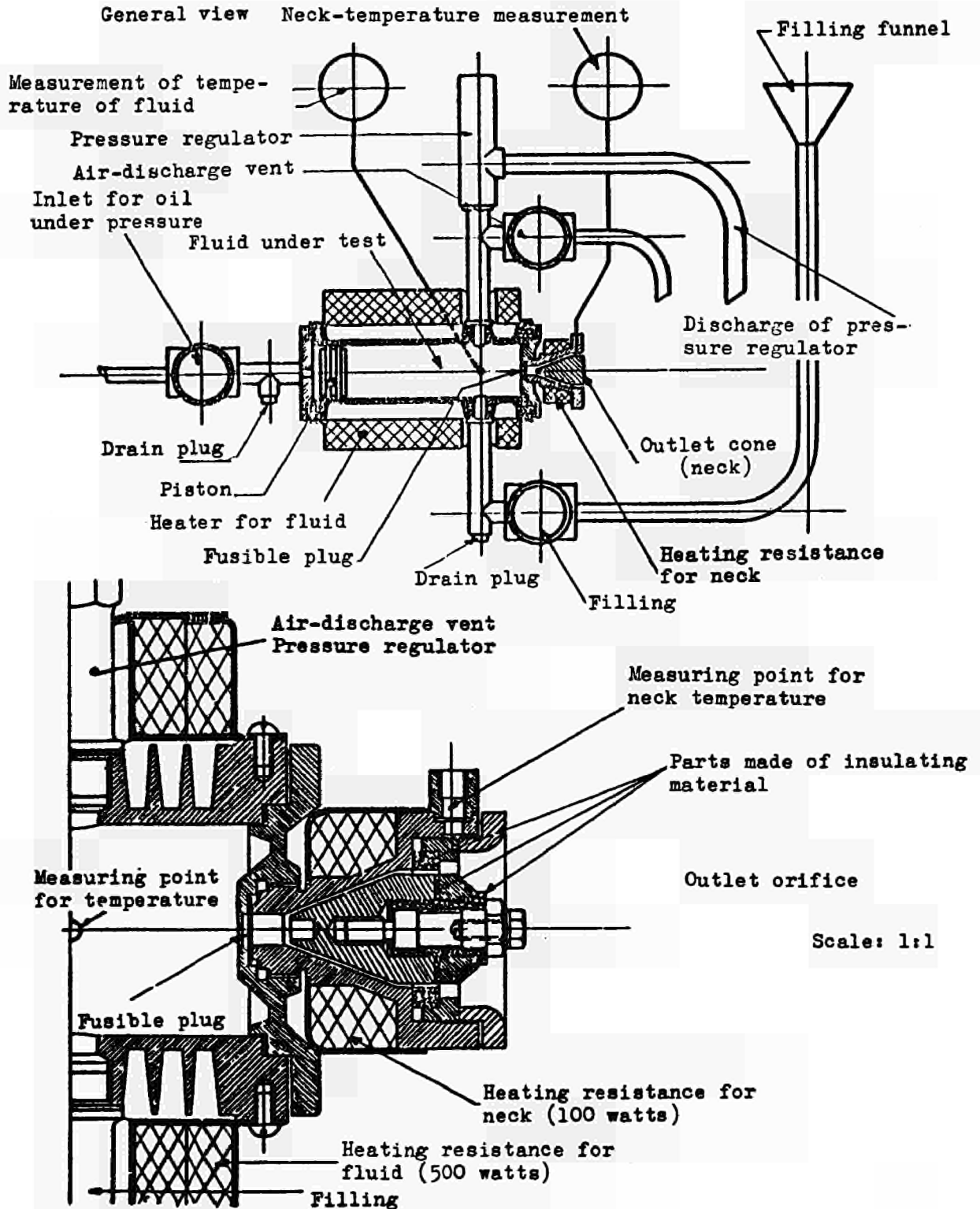



-(b)-

ANNEX III

JIG FOR MAKING FUSIBLE PLUGS

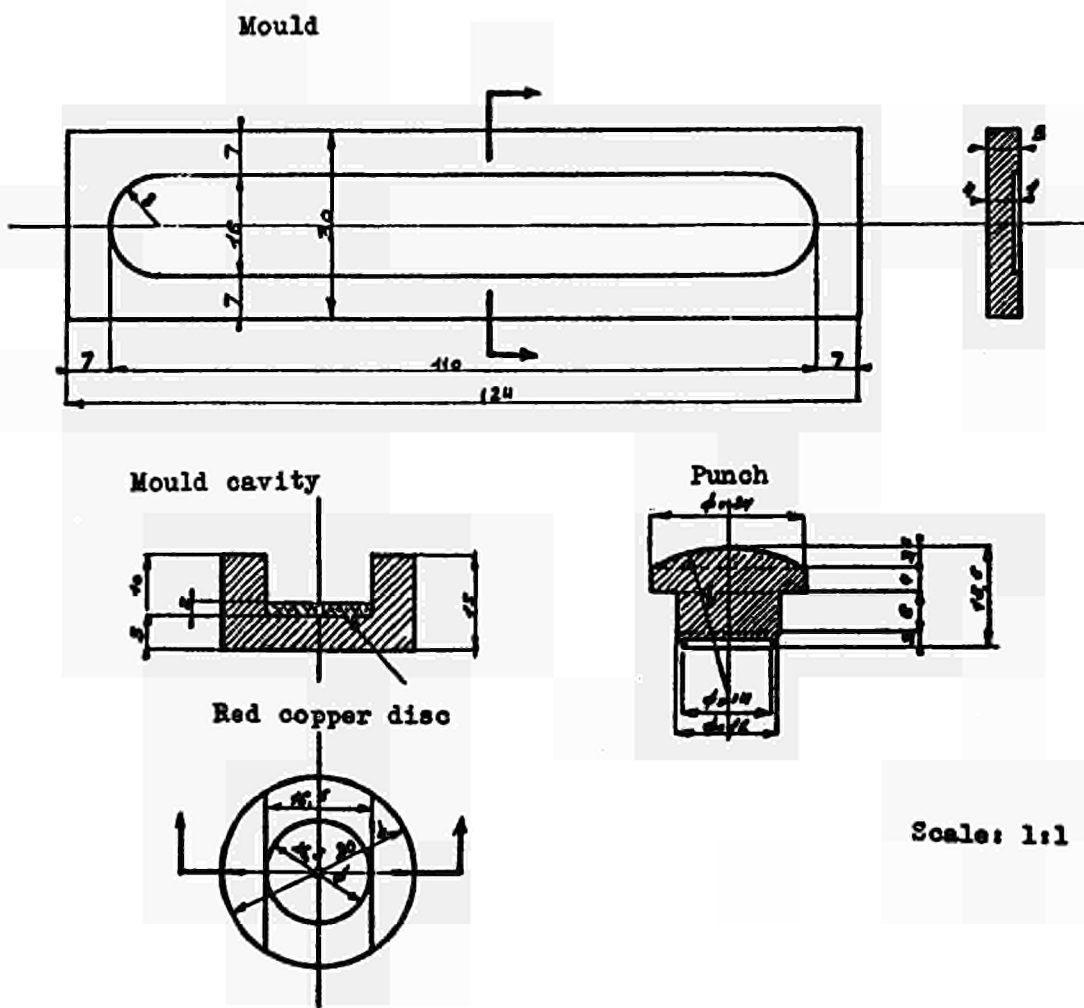





ANNEX IVDETERMINATION OF FLOW TEMPERATURE

(Based on French Standard NF T 60 - 122 - June 1956) (1)

1. INTRODUCTORY REMARKS

With the apparatus used, the flow temperature can be determined from a very thin layer of the substance; this precaution is necessary because of the poor conductivity of solidified substances; the test is carried out in a heating bath of accurately-known temperature and under thermal conditions which allow for the structural changes occurring as a result of variable cooling and avoid any irregularities which might result from these changes. Variations of temperature between successive tests should, as a general rule, not exceed a few tenths of 1°C.

Particular attention is drawn to the fact that tests to determine viscosity at low temperatures on the one hand, and tests to determine flow temperature on the other, are essentially different tests. In each case a special test is used, and the measurement results are valid only for the type of test in which they were obtained.

2. PRINCIPLE

The flow temperature is that temperature at which the fluid, after having been thoroughly and rapidly frozen by suitable treatment and then gradually warmed up again, loses its solidity in such a way that it releases a movable element, which is maintained under constant pressure, this movable element having been frozen into the fluid at the moment of freezing.

3. APPARATUS

The apparatus illustrated in the accompanying diagram consists of a ring-shaped container (A) (which represents the movable element) for the fluid to be examined. The dimensions of this container are: Internal diameter between inner walls 15 mm; internal diameter between outer walls 21 mm; radial distance between the two walls 3 mm, wall thickness 0.4 mm, depth 11 mm, and thickness of the bottom 1.5 mm. This container is fastened to a hollow metal tube (C) by means of a disc pierced at (B) - the tube tapering to a smooth point (D). The vertical metal tube can be inserted in a brass tube serving as a sleeve (E); the brass tube has an internal diameter of 15 mm, an external diameter of 16 mm, and is 234 mm long; at its lower end is a cylindrical element (F) 17 mm in internal diameter, 18 mm in external diameter and 31.5 mm high; this slides into the ring-shaped container (A). The cylinder (F) is pierced by two orifices which are diametrically opposed; they are 12 mm high and 5 mm wide; the bottom of each orifice lies 13.5 mm above the bottom of the cylinder. Tube (C) is set centrally and is maintained in this position with a play of 0.1 mm in the lower part of the sleeve (E) by means of a ring (H) and in the upper part by the locking head (I). To reduce the conductivity of the metal and to avoid the formation of rime, sleeve (E) is provided with six pairs of 10 mm holes, as shown in the diagram; tube (C) is also perforated, by 17 pairs of holes, each 2.5 mm in diameter. The middle of the perforated part of tube (C) bears on the top of locking head (I). This makes it possible to insert a pin (J) in whichever hole in tube (C) has its edge level with the top of the locking head (I), and thereby lock the movable part in the sleeve; a fixed arm (M) with a locking screw at one end holds sleeve (E) firmly in its vertical position, but is not connected to tube (C) nor to container (A). The weight of the movable element is calibrated at exactly 20 g; this movable element moves downwards

---

(1) Published by the Association Française de Normalisation (AFNOR), Paris

if not retained. At the beginning of the test there is rigid connection between container (A) which is filled with solidified fluid and element (F); this element (F) was immersed in the fluid before the latter was frozen. As soon as the melting process begins, the movable element slides downwards until it reaches its end position, which is fixed by pin (J); this pin had been drawn back to its original position after the solidification process and inserted in the top hole of tube (C).

The whole apparatus is now immersed in a double-walled vessel containing 0.13 litre of acetone. A pentane thermometer indicates the temperature of this bath. The upper end of (C) can be brought into contact with the rapid-acting feeler (L), which closes an electric circuit as soon as tube (C) begins to move downwards, thus making it possible to operate an acoustic signal.

#### 4. TEST PROCEDURE

- a) The fluid under test must be at room temperature.
- b) The test fluid, at room temperature, is filled into the ring-shaped container (A) of the apparatus; tube (C) is immediately inserted in sleeve (E), a process which is facilitated by the upper tip of (C); the lower end of the sleeve is now placed in the ring-shaped container until it touches the bottom. Any fluid which has spilled over from the ring-shaped container must be dried off. The movable element is arrested by placing the pin (J) in the hole in tube (C) which lies immediately above locking head (I).
- c) Prepare, in a 250 cc Dewar flask (internal diameter 50 mm, depth 150 mm), a cooling bath at  $-78^{\circ}\text{C}$  obtained by mixing solid carbon dioxide in excess with acetone. Cool until the test fluid freezes solid by immersing the lower part of the apparatus in the cooling bath, in a smooth uninterrupted movement.

It is essential to stop the immersion once the level of the cooling bath is 5 mm below the upper edge of the slots G which immediately precede the container

The apparatus must then be left for 30 minutes in this cooling bath.

- d) The second cooling bath, which must have a temperature  $20^{\circ}\text{C}$  below the flow temperature of the test fluid, is prepared in the double-walled flask which is provided with the apparatus and bears a level mark indicating 130 cc. This cooling bath is made up by adding solid carbon dioxide to the 130 cc of acetone which must be in the inner vessel. The bottom of the inner vessel must be 20 mm from the bottom of the external vessel.
- e) After 30 minutes of immersion in the Dewar flask, the latter is removed and should be replaced quickly by the double-walled vessel; the lower part of the apparatus - fitted with its thermometer, the ball of which is level with the ring-shaped container - is then smoothly and uninterruptedly immersed.

Immersion is stopped when the base of the vessel is 42 mm from the bottom of the interior of the container.

Pin (J) is then removed and placed in the top hole of tube (C). The temperature of the bath is now allowed to rise rapidly. It is not necessary to stir the acetone bath, since the rising bubbles of carbon dioxide ensure homogeneous temperature distribution at all times.

- f) At a given moment, the ring-shaped container starts to move under its own weight and thus begins to leave the stationary sleeve; immediately this movement begins an electric circuit is closed and an acoustic signal given. The downward movement of the mobile assembly is checked by the pin which comes into contact with the head (I) of the sleeve.

## 5. EVALUATION OF TEST RESULTS

The temperature at which the ring-shaped container frees itself from the sleeve is taken to be the normal flow temperature. The reheating time must be not less than 10 minutes. Three flow tests are carried out and the average for the three taken as the flow temperature.

## 6. SPECIAL CASE OF SUBSTANCES WITH FLOW TEMPERATURES ABOVE 0°C

If the flow temperature of the test material is above 0°C, the acetone bath will warm up only slowly from this temperature. To counteract this, and also to permit the determination of flow temperatures above room temperature, a heating plate is inserted between the base of the apparatus and the outer vessel. A resistance is used to regulate the intensity of the current in the heating coil under the plate in such a way that the temperature in the acetone bath rises evenly at approximately 0.8°C per minute.

The procedure is similar to the method of operation indicated above. However, as soon as the temperature in the acetone bath has reached 0°C, the current in the heating plate should be switched on; the test is then continued and, as stated above, the temperature recorded at which the ring-shaped container frees itself completely under the action of its own weight from the sleeve.



FLOW TEMPERATURE TEST

Full diagram

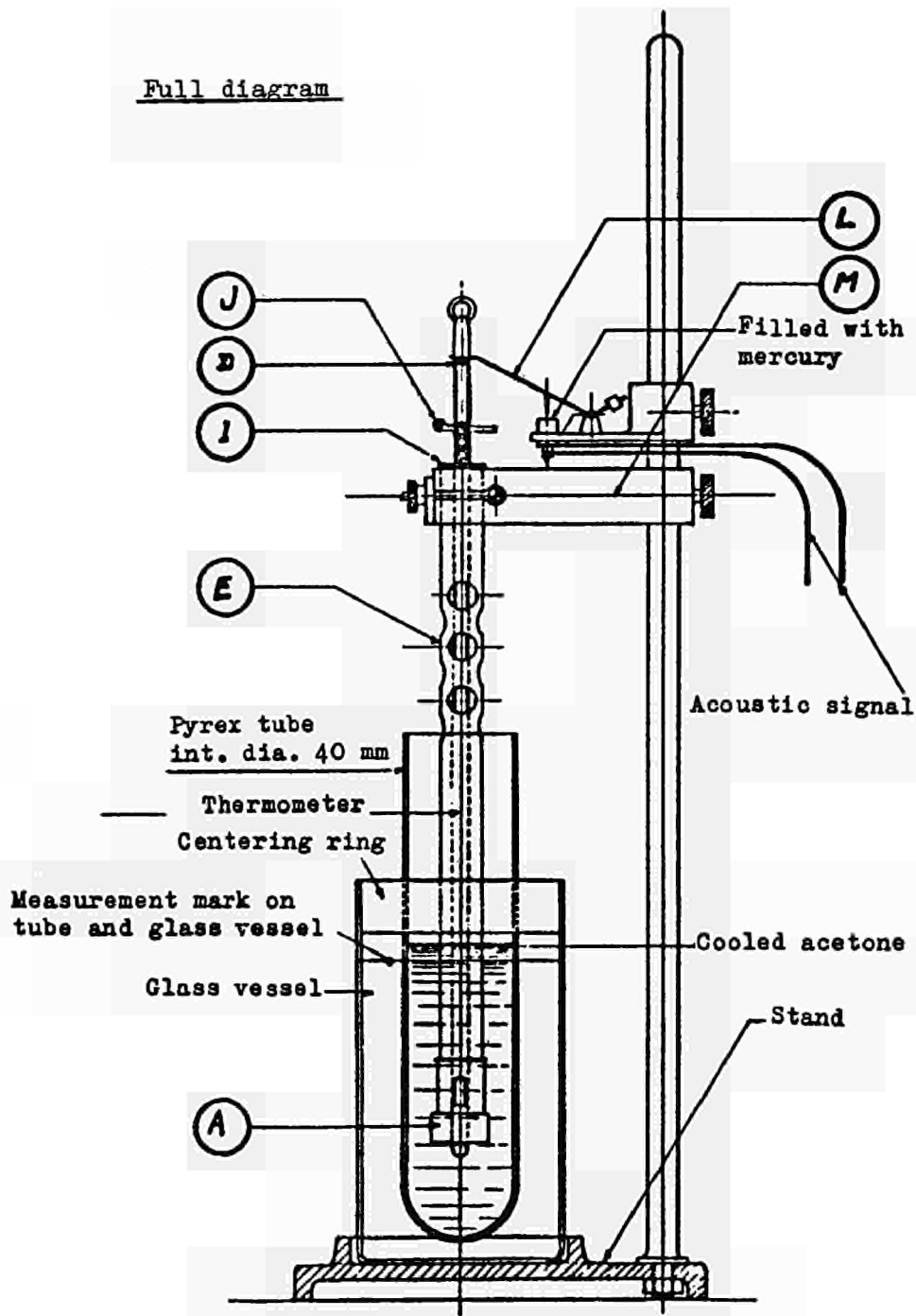



- (b) -

ANNEX IV

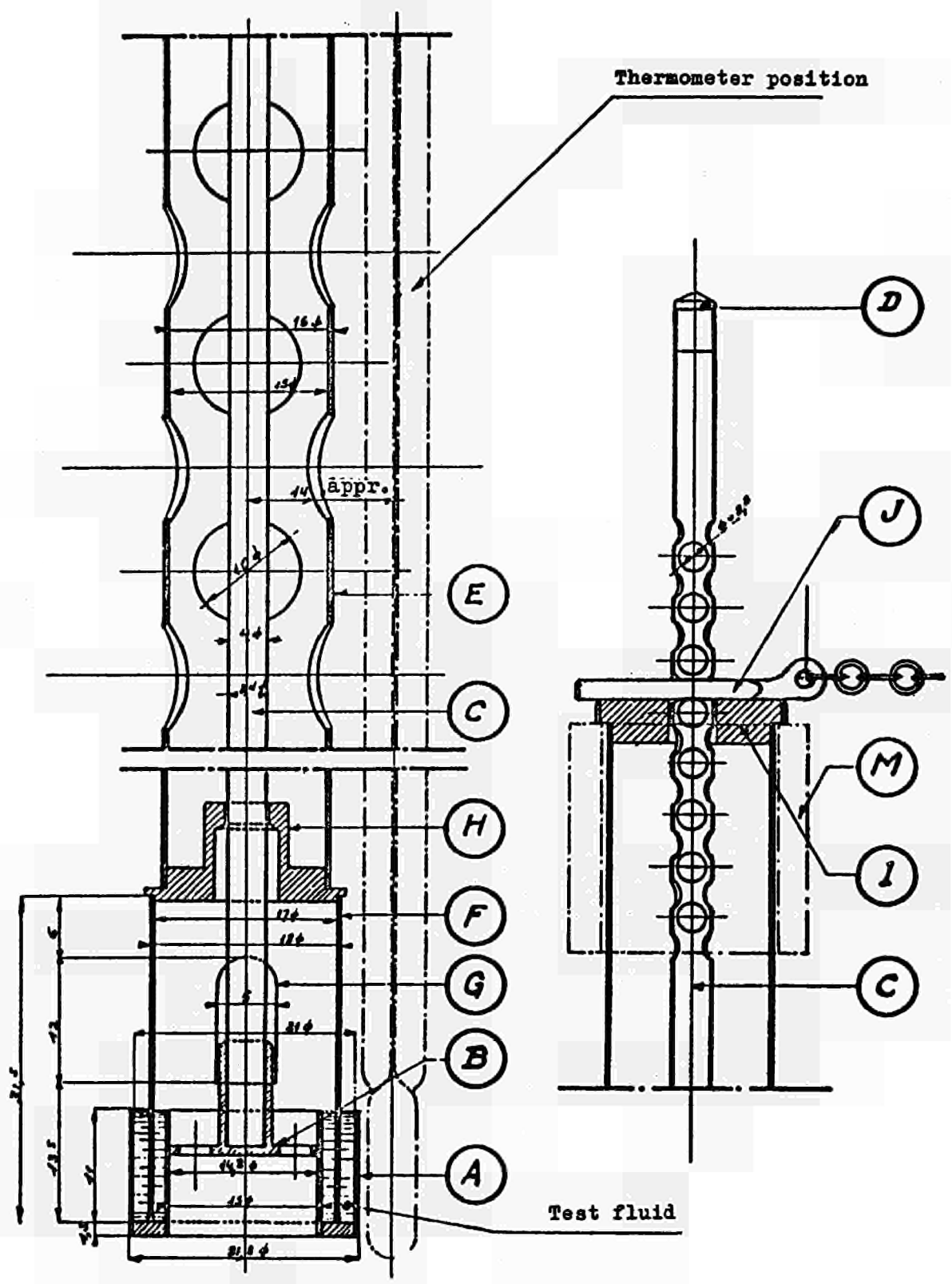





DETERMINATION OF KINEMATIC VISCOSITY1. PRINCIPLE

A tube, calibrated and marked with two measuring marks, is filled with the test fluid. A calibrated sphere is then introduced into the tube and the falling time of the tube between the two measurement marks is recorded. The falling time so recorded can then be used to derive the viscosity by means of the following simple calculation:

$\eta_a$  - Absolute viscosity of the fluid in centipoises

$\eta_c$  - Kinematic viscosity of the fluid in centistokes

K - Calibration for the measurement unit "calibrated tube/drop-sphere employed"

T - Falling time measured in seconds

D - Density of the sphere at measurement temperature

d - Density of the test fluid at measurement temperature

This gives us the formula:  $\eta_a = T \times (D-d) \times K$   
 $\eta_c = \frac{\eta_a}{d} = T \times \frac{D-d}{d} \times K$

2. DENSITY

The densities inserted in this calculation are the densities at the temperature of measurement; they are normally indicated for +15°C, in comparison to water at +4°C. The required corrections can be applied only for homogeneous fluids, and this applies only in certain special cases with non-flammable fluids. For these fluids direct determination of the density is necessary.

Conversion of the density:

c - Correction coefficient for density for a deviation of 1°C

$d_0$  - Density at +15°C

e - Difference between measurement temperature and +15°C in degrees Centigrade

This gives us:  $d = d_0 \pm c \times e$

The correction is positive if the measurement temperature lies below +15°C and negative if it lies above this value.

3. APPARATUSa) Viscosimeter

The measurements can be carried out with two types of apparatus based on the same principle, but of different constructions:

- aa) The Höppler viscosimeter, Type BH, with which measurement is carried out in a tube inclined at an angle of 20° to the vertical;
- bb) The IFC viscosimeter, with which the measurement is carried out in a tube inclined at 30° to the vertical.

Since the number of measurement operations possible depends on the number of spheres provided in the individual types of apparatus, the possible measurement ranges are given in the following table:

Spheres	Höppler, Type BH	IFC
1	0,3 to 3 cSt	1 to 50 cSt
2	3 to 30 cSt	50 to 2,500 cSt
3	25 to 250 cSt	2,500 to 25,500 cSt
4	250 to 2,500 cSt	
5	2,500 to 25,000 cSt	
6	8,000 to 80,000 cSt	

Steel spheres are used in the IFC apparatus, while in the Höppler apparatus Type BH they are made of either steel or glass.

#### b) Thermostats

The accuracy of the measurements depends on the accuracy and the constancy of the test temperature. It is virtually essential to operate with a thermostat, whose temperature must be maintained constant.

- aa) with an accuracy of  $\pm 0,05^{\circ}\text{C}$  at measurement temperatures below  $+20^{\circ}\text{C}$ ;
- bb) with an accuracy of  $\pm 0,10^{\circ}\text{C}$  at measurement temperatures above  $+20^{\circ}\text{C}$ .

For a measurement range from  $-20^{\circ}\text{C}$  up to  $+100^{\circ}\text{C}$  it is recommended to use two different bath fluids according to the measurement temperature required,

- purified kerosene (or aviation spirit) for temperatures below  $+20^{\circ}\text{C}$ ;
- pure glycerine or white vaseline oil for temperatures above  $+20^{\circ}\text{C}$ .

#### c) Description of the apparatus and method of use

The Höppler apparatus Type BH and the IFC apparatus are diagrammatically illustrated in the accompanying sketches. Detailed descriptions are given in the instructions for use issued by the manufacturers, in the French Standard (AFNOR - T 42-011) and in the corresponding German Standard (DIN 53015).

### 4. MEASUREMENT PROCEDURE

The fluid is poured into the calibrated tube; the sphere is also inserted and the apparatus closed again, once any bubbles which may have formed during filling have been removed. The fluid is brought up to test temperature; and six successive measurements are carried out. The time T quoted in the formula given above is the arithmetic mean of the times recorded during these six measurements. These times should lie between 25 and 500 seconds.

This condition requires the use of various spheres for the same fluid, and in particular for measurements at temperatures below  $+50^{\circ}\text{C}$ . The tube must be emptied each time a sphere is changed (40 cc. with the Höppler BH apparatus and 30 ml with the IFC apparatus); in this special case it is not necessary to clean the interior of the calibrated tube.

## 5. NOTES

### a) Constants K

The constants K are independent of the test temperature. They are determined for a given calibrated tube and a precisely-defined inclination of the tube (30° for the IFC apparatus and 20° for the Höppler BH apparatus). When a calibrated tube or any of the spheres are changed, or when measurements are undertaken at an angle other than 30° (using the IFC apparatus) these constants must be determined anew, using a calibrated fluid.

These constants must be indicated in the test report for each individual apparatus.

### b) Thixotropic fluids

In the case of thixotropic fluids the measured falling times will become shorter, from the first measurement onwards, until they reach a constant minimum value at the end of the measurement. The figure to be accepted is the minimum time at which the gel disappears. The difference between the first falling time and the minimum time is an index of the thixotropy of the test fluid. For group B substances, at least 5 successive measurements must be carried out, each value being given separately.

### c) Cleaning the calibrated tube and the spheres

The tube is cleaned with solvents and flushed out with pure ether. In the case of aqueous solutions, cleaning must be carried out by means of a hot solution of soda containing 5 % concentrated ammonia to remove any grease, and then flushed with distilled water.

The spheres are to be cleaned with solvents and with ether, and handled with clean tongs to avoid contact with the fingers.



-(a)-

ANNEX V

MEASUREMENT OF KINEMATIC VISCOSITY

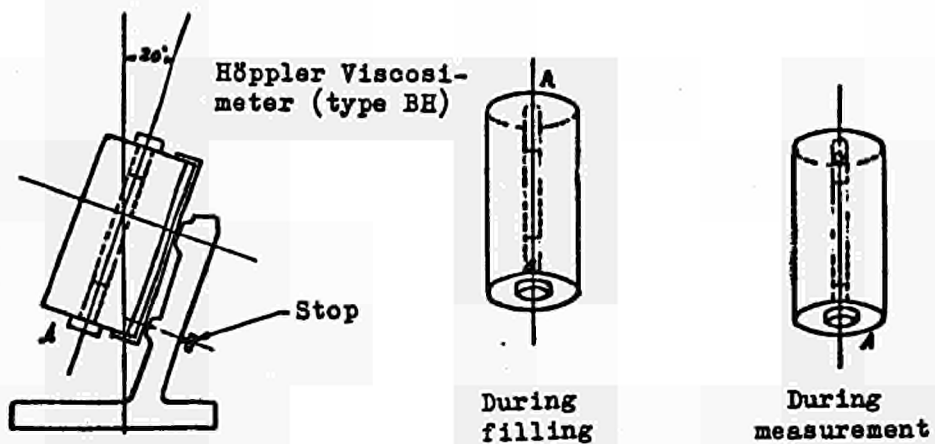
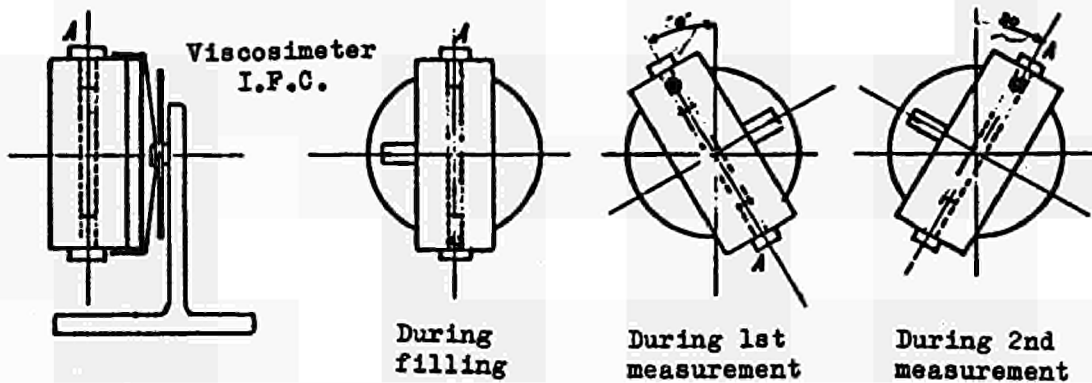



DETERMINATION OF VAPOUR PRESSURE1. PRINCIPLE

The vapour pressure of group D fluids requires to be determined under given conditions at temperatures ranging from room temperature to maximum temperature of utilization. The highest testing temperature is 200°C. The values for vapour pressure are expressed in kg/cm<sup>2</sup>.

2. APPARATUS

- a) A bomb which can be dismantled,
- b) a mercury pressure gauge,
- c) a thermostat-controlled bath,
- d) a thermo-couple.

a) Dismantleable bomb

The bomb used is derived from the Reid bomb, but constructed in such a way that it can be cleaned easily. It consists of two connecting chambers with the following dimensions:

aa) Chamber for test fluid

- internal diameter 54 mm
- height of the inner cylindrical portion 60 mm;

bb) Air chamber

- internal diameter 54 mm
- height of the inner cylindrical portion 250 mm

The two chambers are connected by an intermediate piece with a lateral orifice serving as a vent during filling, and as a level indicator for the test fluid. Above the air chamber is the connecting tube to which the mercury is attached. The thermocouple is also attached to this tube; the point at which the thermocouple is introduced is sealed off. To make it possible to isolate the bomb, a tight cock is fitted around the connection between the bomb and the mercury gauge.

The volumetric ratio between the air chamber and the fluid chamber is very nearly 4. The diagram shows the bomb assembly.

b) Mercury pressure gauge

This pressure gauge corresponds to the accompanying sketch. At the lower end is a tight sealing-off cock by means of which the level of the mercury can be adjusted to the zero point of the gauge. The mercury gauge is connected to the air chamber by a reinforced rubber tube which is not subject to chemical attack, and has an internal diameter of roughly 3 mm. The gauge is provided with a millimetre scale.

c) Thermostat-controlled bath

The thermostat-controlled bath must be big enough to allow of the completely-assembled bomb being immersed in it sufficiently deeply for the upper part of the air chamber to be at least 30 mm below the level of the fluid bath.

It is preferable to use oil as the bath fluid, to enable a temperature of 200°C to be reached.

The heating apparatus must be such that a stable temperature can be maintained for each stage of measurement.

d) Temperature-measuring device

- Bath

The temperature of the bath in the thermostat should be measured by means of a thermometer with a centigrade scale.

- Test fluid

The temperature-measuring device should preferably be a thermocouple housed in a cylindrical sleeve with a maximum external diameter of 8 mm.

e) Safety precautions

Each new bomb must be tested for water- and air-tightness, by being subjected to an air pressure of 7 kg/cm<sup>2</sup>. No air should escape from the bomb when it is under water.

### 3. TEST METHOD

a) Preparation of the test

The individual components of the bomb should be thoroughly cleaned, rinsed and dried and then maintained at a temperature of 25°C.

The quantity of fluid required (approximately 160 ml) for the test must be kept for at least one hour at a temperature of 25° ± 1°C.

b) Filling the fluid chamber

This chamber is to be filled before it is assembled with the other components. The piece connecting it with the air chamber is then attached; during this operation, it is essential not to forget to remove the screw which closes the air vent. The lower chamber should then be further filled until the fluid reaches the level of the air vent. At this moment the air vent should be closed by means of the screw provided for the purpose; the air chamber is then set in place and the upper orifice closed. The cock at the pressure-measuring point is meanwhile left open, to avoid the occurrence of any excess pressure in the bomb.

The thermocouple is then attached; the measuring head must lie 30 mm from the bottom of the lower chamber, in the middle of the test fluid.

c) Test procedure

The bomb is placed in the thermostat which is maintained at a temperature of 25° ± 1°C and the mercury gauge connected. When the cock at the pressure-measuring point is open, the mercury gauge must indicate precisely zero. Heating is carried out in stages of 25°C; measurements are taken at 50, 75, 100, 125, 175 and 200°C. The rate of heating is adjusted so that the temperature rises 1°C per minute within each step of 25°C. At the final heating stage, 200°C, the thermostat must be capable of keeping the temperature constant within ± 1°C for at least ± 5 minutes; the pressure should be read at the beginning of this period of 5 minutes and at the end by means of the mercury gauge.



d) Presentation of results

Corrections must be made to the differences in level read off on the mercury pressure gauge. The attached Table (Annex VI -b-) gives the correction factors, expressed in millimetres of mercury, for different values of the atmospheric pressure obtaining in the room where the test is carried out; these values have been prepared for the range of temperature from +20° to +200°C. Corrections in respect of atmospheric pressures lying between the values given in the Table are obtained by interpolation.

Calculations were based on an air atmosphere at +25°C, with a hygrometric index of 0.6. The figures apply to a hygrometric index between 0.5 and 0.7, the maximum deviation from the figures in the table being below 0.8 mm of mercury at +200°C.

The corrected value must be converted to terms of kg/cm<sup>2</sup>.



-(a)-

ANNEX VI

DETERMINATION OF VAPOUR PRESSURE

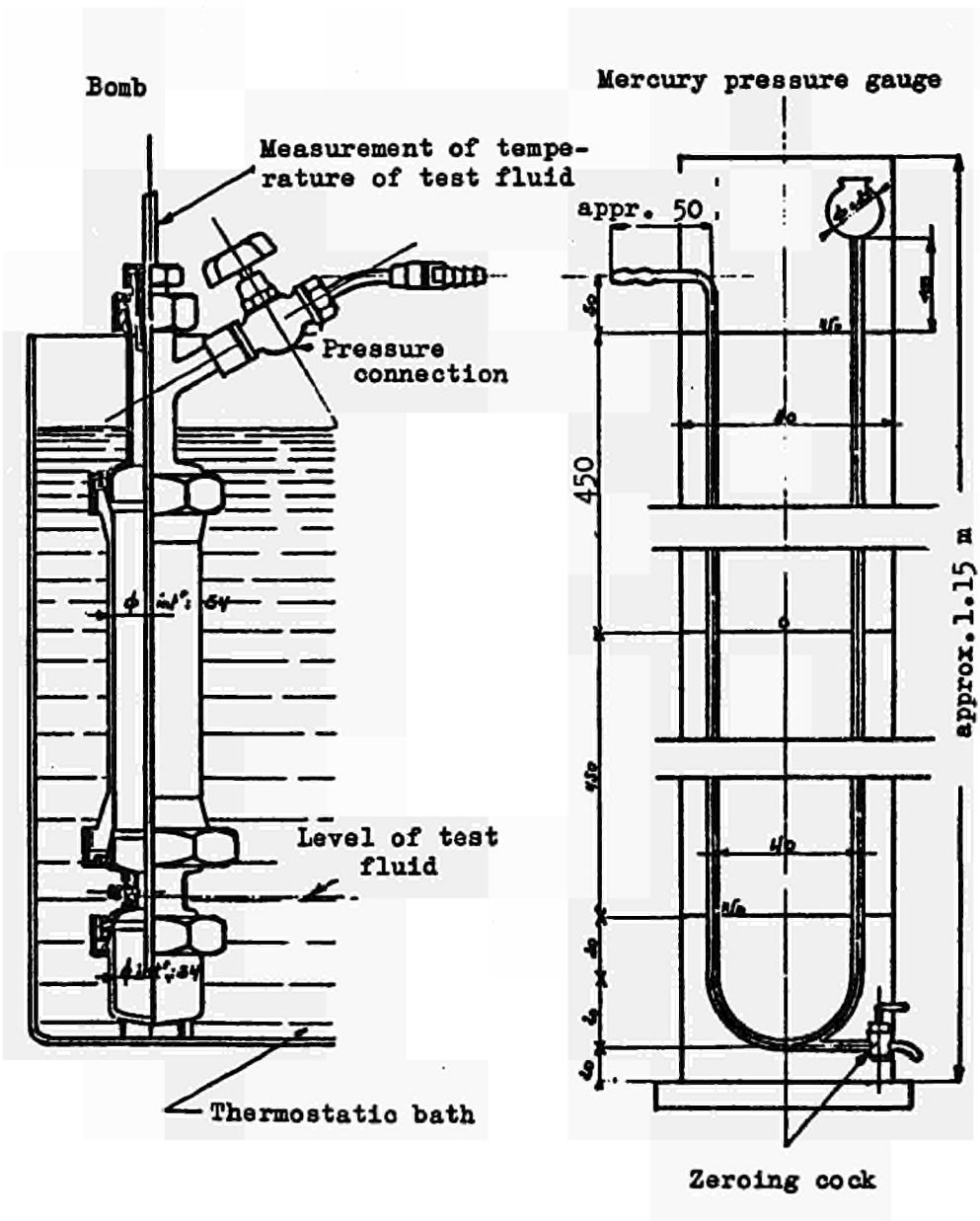



Table of corrections in mm of mercury

Temperatures in °C	Atmospheric pressures, in mm of mercury				
	740	750	760	770	780
+ 20	+ 12,7	+ 12,9	+ 13	+ 13,2	+ 13,3
+ 25	0	0	0	0	0
+ 30	- 12,6	- 12,6	- 12,8	- 13,1	- 13,3
+ 35	- 24,5	- 24,7	- 25	- 25,3	- 25,7
+ 40	- 37,1	- 37,6	- 38,1	- 38,6	- 39,1
+ 45	- 49,8	- 50,4	- 51	- 51,8	- 52,5
+ 50	- 62,5	- 63,3	- 64,1	- 64,9	- 65,8
+ 55	- 75,1	- 75,9	- 77,2	- 78,1	- 79,2
+ 60	- 86,9	- 88	- 89,2	- 90,4	- 91,6
+ 65	- 99,9	- 101,2	- 102,5	- 103,8	- 105,2
+ 70	- 112,2	- 113,7	- 115,2	- 116,8	- 118,4
+ 75	- 124,8	- 126,5	- 128,2	- 129,9	- 131,6
+ 80	- 136,5	- 138,4	- 140,3	- 142,2	- 144,1
+ 85	- 149,3	- 151,3	- 153,3	- 155,3	- 157,3
+ 90	- 162,2	- 165,3	- 167,5	- 168,7	- 170,9
+ 95	- 174,9	- 177,2	- 179,6	- 182	- 184,4
+ 100	- 187,4	- 189,9	- 192,5	- 195	- 197,6
+ 110	- 211,2	- 214	- 216,8	- 219,6	- 222,5
+ 120	- 236,1	- 239,3	- 242,5	- 245,7	- 248,9
+ 130	- 260,4	- 263,9	- 267,5	- 271	- 274,5
+ 140	- 285,3	- 289,1	- 293	- 297	- 300,9
+ 150	- 309,8	- 314	- 318,2	- 322,4	- 326,6
+ 160	- 334,6	- 339,1	- 343,6	- 348,2	- 352,8
+ 170	- 359,4	- 364,2	- 369	- 373,8	- 378,7
+ 180	- 383,9	- 388,9	- 393,9	- 399	- 404,1
+ 190	- 408,8	- 414,3	- 419,8	- 425,3	- 430,9
+ 200	- 432,9	- 438,7	- 444,5	- 450,4	- 456,3

ANNEX VI



DETERMINATION OF pH VALUE1. FIELD OF APPLICATION

The method serves to determine the degree of acidity or alkalinity of groups A and C fluids employed in hydraulic systems.

2. PRINCIPLE

The pH value is obtained by means of an electrometric determination of the potential difference between two electrodes plunged into the test fluid. Glass and calomel electrodes are used. The measurement is carried out at 18°C.

3. APPARATUS AND REAGENTS

- a) pH-meter
- b) Glass electrode (measurement electrode, alkali-resistant)
- c) Saturated calomel electrode (reference electrode)
- d) Buffer solution

## I. Buffer solution pH = 7

- 1) 1.1876 g  $\text{Na}_2\text{HPO}_4 + \text{H}_2\text{O}$  in 100 ml dist.  $\text{H}_2\text{O}$
  - 2) 2.1008 g  $\text{C}_6\text{H}_8\text{O}_7 + \text{H}_2\text{O}$  (Citric acid) in 20 ml  
1 n - NaOH + 80 ml dist.  $\text{H}_2\text{O}$
- Mixture: 32.94 ml solution 1) + 7.06 ml solution 2)

## II. Buffer solution pH = 10

- 1) 1.91 g  $\text{Na}_2\text{B}_4\text{O}_7 + 10 \text{H}_2\text{O}$  (borax) in 100 ml dist.  $\text{H}_2\text{O}$
  - 2) 0.1 n - NaOH
- Mixture: 59.5 ml solution 1) + 40.5 ml solution 2).

4. PREPARATION

The two electrodes are connected to the measuring device and inserted successively in buffer solutions I and II which have been brought up to 18°C. The actual readings given by the apparatus are compared with the theoretical values. If the theoretical values (pH 7 and pH 10) are not those indicated by the apparatus, the actual readings are adjusted in accordance with the instructions for use of the apparatus.

#### 5. TEST PROCEDURE

The test fluid is warmed up to 18°C in a glass beaker. The electrodes (washed clean with distilled water) are then inserted and the pH value read off on the pH-meter.

#### 6. PRESENTATION OF RESULTS

The results are given to the nearest 0.1 pH unit.



ANNEX VIIIDETERMINATION OF SHEAR STRENGTH1. FIELD OF APPLICATION

The method serves to determine the mechanical shear strength of fluids used in hydraulic systems. It may be applied to all types of hydraulic fluid. The only exception is group A fluids with a viscosity of less than 10 centistokes at 20°C.

2. PRINCIPLE

A given volume of fluid is put through an injector a given number of times. The following characteristics are recorded before and after the test, to establish any variations: viscosity, flow temperature, pH (neutralization value for group D fluids), moisture content.

3. APPARATUS AND SOLVENTS

- a) The apparatus conforms to the accompanying diagram. The injector is a Bosch-type KD 45 SA/53/1, with a DN O SD 211-type spray nozzle. This nozzle must be set at 100 kg/sq.cm.
- b) Glass containers (3 and 3a) with non-tight lids.
- c) Three-way tap and tubing to connect container 3a with the injector pump.
- d) Stop watch
- e) 400-ml beaker
- f) Solvents to clean the glass units: crystallizable benzene or petroleum-based petrol for group B fluids, water for groups A and C fluids, trichlorethylene or monochlorobenzene for group D fluids, and pure ethyl alcohol for drying after washing with water.

4. PREPARATIONS FOR THE TEST

- a) 250 ml of the fluid to be tested are poured into container 3, the three-way cock being in position 6.
- b) Screw 13 is unscrewed to allow the air to escape from pump 14; as soon as the fluid starts to flow steadily, screw 13 is tightened.

## 5. TEST PROCEDURE

- a) Start the motor
- b) Start the stop-watch as soon as the fluid begins to flow through check tube 2.
- c) Ensure that pressure in the return circuit is in fact between 100 and 110 kg/sq.cm, using pressure gauge 11, by turning tap 12. This tap must be shut after the check.
- d) After 30 minutes' running time - corresponding to at least 50 cycles, stop the motor. Turn the 3-way tap cock to position 5 and collect the fluid into a clean pyrex beaker (normally the temperature of the fluid at this stage is above 55°C). Empty the circuit by re-starting the motor for a few moments until the flow from tube 2 has stopped.

### NOTE

There should not be much flow from tube 8; an appreciable return of fluid via tube 8 may occur when testing viscous liquids (viscosity 120 centistokes at +50°C)

## 6. CLEANING

- a) Cleaning the circuit: Since even partial dismantling of the assembly is out of the question, cleaning is carried out before each test by circulating 100 to 150 ml of the test fluid for 10 minutes. If the subsequent tests relate to fluids of the same group, one single run is enough. If they deal with a fluid of a different group from that of the last fluid tested, it will be necessary to flush at least twice. The flushing fluid must be removed each time.
- b) Cleaning of glassware and the tubing. This is done with solvents and products appropriate to the fluids tested (see paragraph 3.f).

## 7. PRESENTATION OF RESULTS

- a) The following tests must be made on the fluid collected after the shear test:
  - viscosity: at -20, +0, +20, +50 for groups C and D, at +20 and +50 for groups A and B,
  - flow temperature for all groups,
  - pH-value: for groups A and C, and neutralization value for groups B and D,
  - moisture content for groups A, B and C.
- b) The results of these tests are compared with those obtained from the same tests on fluids before the shear test.

- (a) -

ANNEX VIII

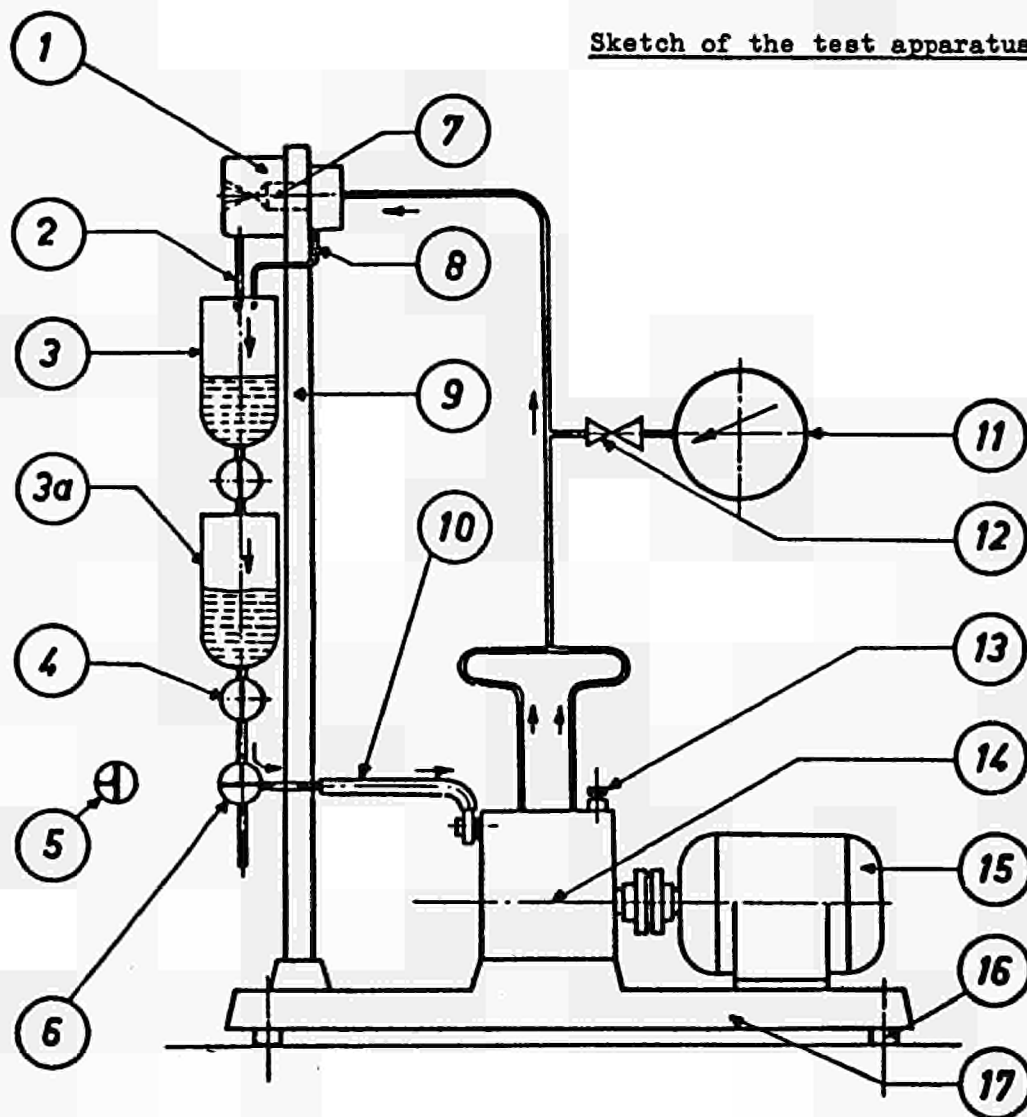
SHEAR STRENGTH TESTSketch of the test apparatus**Legend:**

- |                                   |   |
|-----------------------------------|---|
| 1. Atomizing chamber              | 10. Connection to pump intake                             |
| 2. Outlet for atomized fluid      | 11. Pressure gauge, 0/250 kg/sq.cm.                       |
| 3. Glass container, with cover    | 12. Pressure-gauge tap                                    |
| 3a. - ditto -                     | 13. Valve to evacuate air from pump                       |
| 4. Stop cock                      | 14. Two-cylinder injection pump,<br>e.g. Bosch PE 2 B/100 |
| 5. 3-way cock at the end of test  | 15. Electric motor, 1.1 kW, 920 r.p.m.                    |
| 6. 3-way cock during test         | 16. Rubber buffers  |
| 7. Injector, set at 100 kg/sq.cm. | 17. Base-plate  |
| 8. Excess-fluid return            | 18. Direction of flow of test fluid                       |
| 9. Support                        |   |



DETERMINATION OF ANTI-CORROSION ACTION1. FIELD OF APPLICATION

The method is employed to determine the anti-corrosion action of fluids used in hydraulic systems. The method can be applied to all groups of hydraulic fluid.

2. PRINCIPLE

The samples of various materials are partly immersed in the hydraulic fluid under test for a fixed period of time. The change in weight of the samples and changes in the surface of the material, as well as changes in the colour of the test solution must be recorded.

3. APPARATUS AND REAGENTS

- a) Glass beakers, 500 ml capacity (tall type);
- b) Watch-glasses, to cover the beakers;
- c) Glass hooks, from which the sample sheets can be freely suspended in the beaker;
- d) Thermostatically-controlled and adjustable heating bath which maintains the test fluid in the beaker at a temperature of  $35^{\circ} \pm 1^{\circ}\text{C}$ . The heating bath must be provided with a stirring device ensuring uniform temperature distribution throughout the bath; a drying cupboard with similar temperature regulation can be substituted for the thermostatically-controlled bath.
- e) Emery paper No. 0;
- f) Cotton wool;
- g) Normal petrol, boiling range 65 to  $95^{\circ}\text{C}$ ;
- h) Pure benzene;
- i) Sample sheet 100 mm x 20 mm x 1 mm thick, with a 4 mm diameter hole at the upper edge of one narrow side, so that the plate can be hung on a glass hook.
- j) Analytical balance with a sensitivity of 0.0002 gm.

The following materials must be available for the test:

Steel, strength 50 to  $60 \text{ kg/mm}^2$ ,

Electrolytic copper,

Zinc, pure,

Aluminium, pure,

Cadmium-plated steel (steel with a cadmium coating at least 25 microns thick)

Brass (70/30)

NOTE

The same tests can be applied to all other metals and alloys used in the manufacture of underground equipment.

4. PREPARATION

The sample sheets should be prepared with suitable emery paper, until finally emery paper No. 0 gives the best possible surface finish. The sheets are then held in tweezers and cleaned with dry cotton wool, followed by cotton wool soaked in normal petrol. The traces of cotton wool are washed off with normal petrol and then with benzene. As soon as the last traces of solvent adhering to the sample sheets have evaporated, the sheets are placed on the analytical balance. They are then to be used immediately for the corrosion tests.

10 beakers should be filled for the entire test - each with 250 ml of fluid. The glass beakers are then placed in the thermostatically-controlled heating bath and the temperature of the heating bath adjusted to give a constant temperature of  $35 \pm 0.2^\circ\text{C}$  in the test fluid.

6 of the beakers receive one each of the following sample sheets - steel, copper, zinc, aluminium, cadmium-plated steel and brass - suspended in such a way that approximately 60 mm of the sample sheet is immersed in the test fluid. To test the behaviour of pairs of substances, sheets of the following metals are immersed in four beakers:

Steel - Cadmium-plated steel,  
Copper - Zinc,  
Aluminium - Zinc and  
Steel - Aluminium.

The two sample sheets should hang approximately 1 mm apart.

The eleventh beaker contains 250 ml of the test liquid, in which no sample has been immersed, and serves to check any precipitation from the liquid itself during observation.

In every case, the beakers must be covered with watch-glasses to reduce evaporation.

5. PROCEDURE

Care must be taken during the test to maintain the temperature in the heating bath constant. The complete test must run for a minimum of 28 days.

6. ASSESSMENT

At the end of the test, the operators must describe the changes in the surface of the test sheets with respect to any oxidation colour, corrosion and deposit. In addition, for each analysis of the metal surfaces, a record must be made of the colour and appearance of the test solution, and of deposits in the fluid. After visual examination, the operators must cover the samples with ethyl alcohol (the samples must not be rubbed) and dry them by means of oil-free air under pressure. The samples prepared in this way are then weighed on the analytical balance.

The difference in weight is expressed in mg per sample, and the operators must record both increases (+) and losses (-) in weight.

ANNEX X (A)DETERMINATION OF THE RESISTANCE TO AGEING OF FLUIDS CONTAINING NO WATERNOTE

This method uses the apparatus and the ageing conditions described in the standard method ASTM D 943-54.

The method used to study the aged sample has been modified to cover the field of application of fluids containing no water.

1. FIELD OF APPLICATION

This method serves to determine the characteristics of resistance to ageing of non-flammable fluids containing no water, used in hydraulic systems.

2. PRINCIPLE

The sample is subjected to a temperature of 95°C, in the presence of water and oxygen, with iron and copper present to act as catalysts.

3. APPARATUS AND CHEMICALS

- a) Oxidizing cell (fig. 1).
- b) A thermostatically-controlled and adjustable heating bath which maintains the sample in the oxidizing cell at a temperature of  $95 \pm 0,2^\circ\text{C}$ , provided with a suitable stirring device to ensure that the bath temperature is uniform. The dimensions of the bath must be such that the required number of oxidizing cells can be completely surrounded by the fluid in the bath to a height of 350 mm.
- c) Flow-meter with a minimum capacity of 3 litres/hour and an accuracy of  $\pm 0,1$  litre /hour.
- d) A device for winding the catalyzing coils (fig. 2).
- e) Thermometer graduated from 75 to 125°C.
- f) A catalyst consisting of low-alloy steel, No. 16, made by Washburn and Moen (low-alloy steel wire, material type A, specification ASTM A 129, 1st part, ASTM Standards 1955, for open steel electric heating-plates of ordinary quality), the wire being 1.59 mm in diameter, together with a wire of electrolytic copper, No. 14, made by the American Wire Company, the wire being 1.625 mm in diameter.
- g) Hydrochloric acid, concentrated industrial grade ( $\gamma = 1.18$ ).
- h) Hydrofluoric acid, concentrated industrial grade (approx. 50 %).
- i) Ordinary petrol, boiling range 65 to 95°C.
- j) Nitric acid, concentrated industrial grade ( $\gamma = 1.42$ ).
- k) Oxygen in a container with a pressure regulator. It is advisable to use an oxygen bottle with a two-step regulator.

#### 4. PREPARATION OF THE APPARATUS

##### a) Cleaning the catalyst

On the day fixed for the start of the test, 3 m of steel wire and 3 m of copper wire are cleaned with cotton wool soaked in normal petrol; the surface of the wire is then finished smooth with emery paper No. 100 (00). Any traces of metal or emery are then wiped off with dry cotton waste. In all subsequent operations, the wire should be handled with cotton cloth or cotton gloves to avoid contact with the operator's skin.

##### b) Preparation of the coils

The two wires are firmly joined at one end by making about six turns, and then wound on a threaded spindle (fig. 2). The free ends of the steel wire and copper wire are then also attached by six turns; the coils are removed from the spindle and then reduced in length until the top edge of the coils - when slid over the oxygen-inlet pipe - stands 13 mm below the boundary surface of the water, before the latter has been poured in (fig. 1).

This fixing of the length makes it possible to take samples periodically from inside the oxidizing cell for analyses purposes, without materially changing the ratio of the volumes to be examined with respect to the active surface area of the catalyst.

##### c) Cleaning the oxidizing cell

The inlet tubes and reaction vessels are cleaned by rinsing with acetone, tap water, chromo-sulphuric acid and again tap water, until the latter contains no more acid. The objects are then twice rinsed with small quantities of acetone and three times with distilled water. Finally, the reaction vessel is filled with distilled water, the oxygen-inlet pipe is put in place, together with the cooling jacket, and the whole assembly is left in this condition for 24 hours before beginning the test. Shortly before the test begins, the vessels are emptied and dried and the outer walls of the inlet pipe and the cooling jacket dried with cotton waste.

##### d) Cleaning the vessels after use

After the reaction, vessels should be washed with normal petrol and wiped with a long-handled brush. This cleaning process is repeated with acetone replacing the petrol, after which the tubes are filled with oxidizing mixture composed of three parts of HCl and one part of HNO<sub>3</sub> which is left in the apparatus for at least 24 hours at room temperature. The apparatus is then rinsed with tap water to remove all traces of acid and the organic reaction products are removed by means of acetone. If a ring-shaped mark remains in the interior of the vessel, it should be rinsed with a mixture of equal parts of hydrofluoric acid and hydrochloric acid.

This mixture of acids should be left in the vessel until the ring-shaped mark disappears or dissolves, and the acid is then rinsed away with large quantities of tap water. The final cleaning is then carried out as in paragraph c).

#### 5. ANALYSIS PROCEDURE

- a) The bath is heated to a temperature sufficiently high to ensure that the test fluid, contained in the required number of reaction vessels, reaches the prescribed temperature of  $95^{\circ} \pm 0.2^{\circ}\text{C}$ .
- b) The catalyzing coils are then slid over the inlet orifice of the oxygen-inlet pipe, and coil and pipe are centred. A quantity of 300 ml of test fluid is poured on to the coils until they are completely wetted. The reaction vessel is then immersed in the heating bath in such a way that the fluid in the bath stands at least 75 mm



above the surface of the test fluid. The cooling jacket is then pushed on the inlet pipe and connected to the cooling water supply (the temperature of the cooling water must not exceed 35°C during the test).

- c) The oxygen-inlet pipe is connected to the oxygen bottle via the flowmeter, the quantity of gas being adjusted to  $3 \pm 0.5$  litres/hour, and the flow of gas is allowed to continue for 30 minutes before pouring 60 ml of distilled water into the oxidizing cell. The time when this is done is recorded.

It is necessary to adjust the volume of oxygen at least twice a day to comply with the prescribed tolerances.

- d) At least three hours before the beginning of the test the temperature of the mixture in the reaction vessel must be checked every hour until the temperature measured on two successive occasions is constant at  $95 \pm 0.2^\circ\text{C}$ . Thereafter it is necessary to check once a day that the bath temperature remains constant over the entire test period.
- e) By constantly topping-up with distilled water the level of fluid in the oxidizing cell is maintained constant.

In certain conditions, because of deposits or the formation of emulsions, the fluid cannot easily be inspected. For this reason it is necessary to mark the fluid level before the test begins. If this level is maintained by periodic topping-up, the volume of water in the cell remains constant. If test samples are removed from the cell, the total reduced volume obtained in this way is marked and the volume of water maintained exactly to this mark.

## 6. ANALYTICAL DETERMINATION OF THE AGEING PROCESS

- a) During the ageing process, a sample is taken roughly every 8 days from the centre of the fluid in the reaction vessel - the quantity being about 10 ml for analysis, after stopping the oxygen supply.
- b) The 10 ml sample is divided into two parts, one (approx. 5 g) being used to determine the neutralization value, the other to determine the presence of substances (particles of sludge) insoluble in benzene.
- c) Determination of the neutralization value

This determination is carried out by the normal commercial method using alkali blue as a colour indicator.

- d) Determination of the proportion of particles insoluble in benzene

Some 5 g of the sample are dissolved in a flask in 10 times this quantity of pure benzene. This solution is filtered under slight suction on a membrane filter which has previously been weighed (type: average pore diameter 0.4 microns, filter diameter 40 mm). Care must be taken to ensure that the filter is not subjected to dry suction because this blocks the pores. The filter is then washed with pure benzene until the filtrate is completely clear. After it has been allowed to stand for an hour, the benzene is completely evaporated from the filter. The membrane filter is then placed to dry for half an hour in a desiccator and weighed. It is advisable to carry out a blank filtering test with pure benzene, since the filter itself may undergo a weight loss of 1 to 2 mg when treated with benzene.

- e) The duration of the test must not exceed 600 hours of ageing. Once the ageing is finished, other tests of different kinds can be carried out if this is desired.



- (a) -

ANNEX X (A)

METHOD FOR DETERMINING THE RESISTANCE TO AGEING OF  
FLUIDS CONTAINING NO WATER

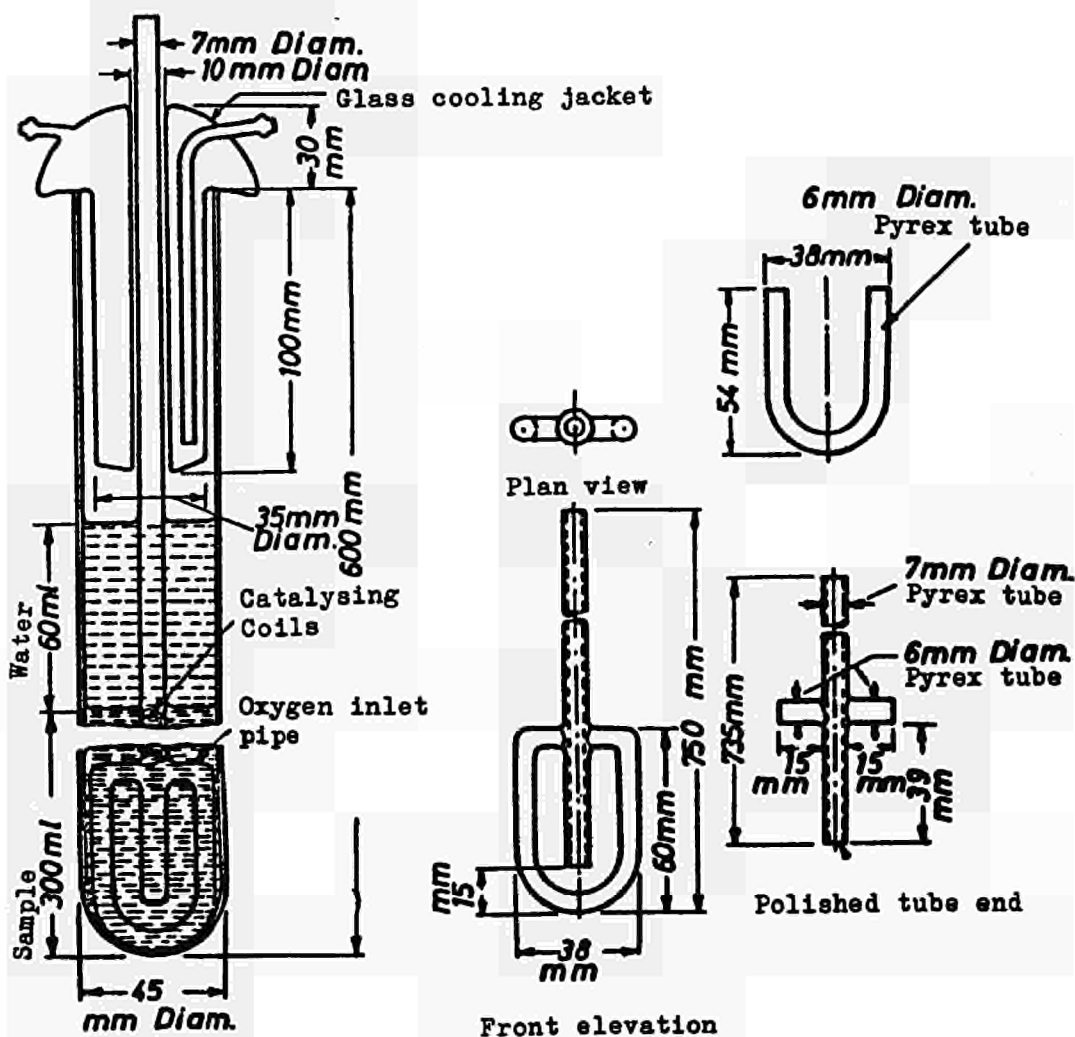

Fig. 1: OXIDIZING CELL



-(b)-

ANNEX X (A)

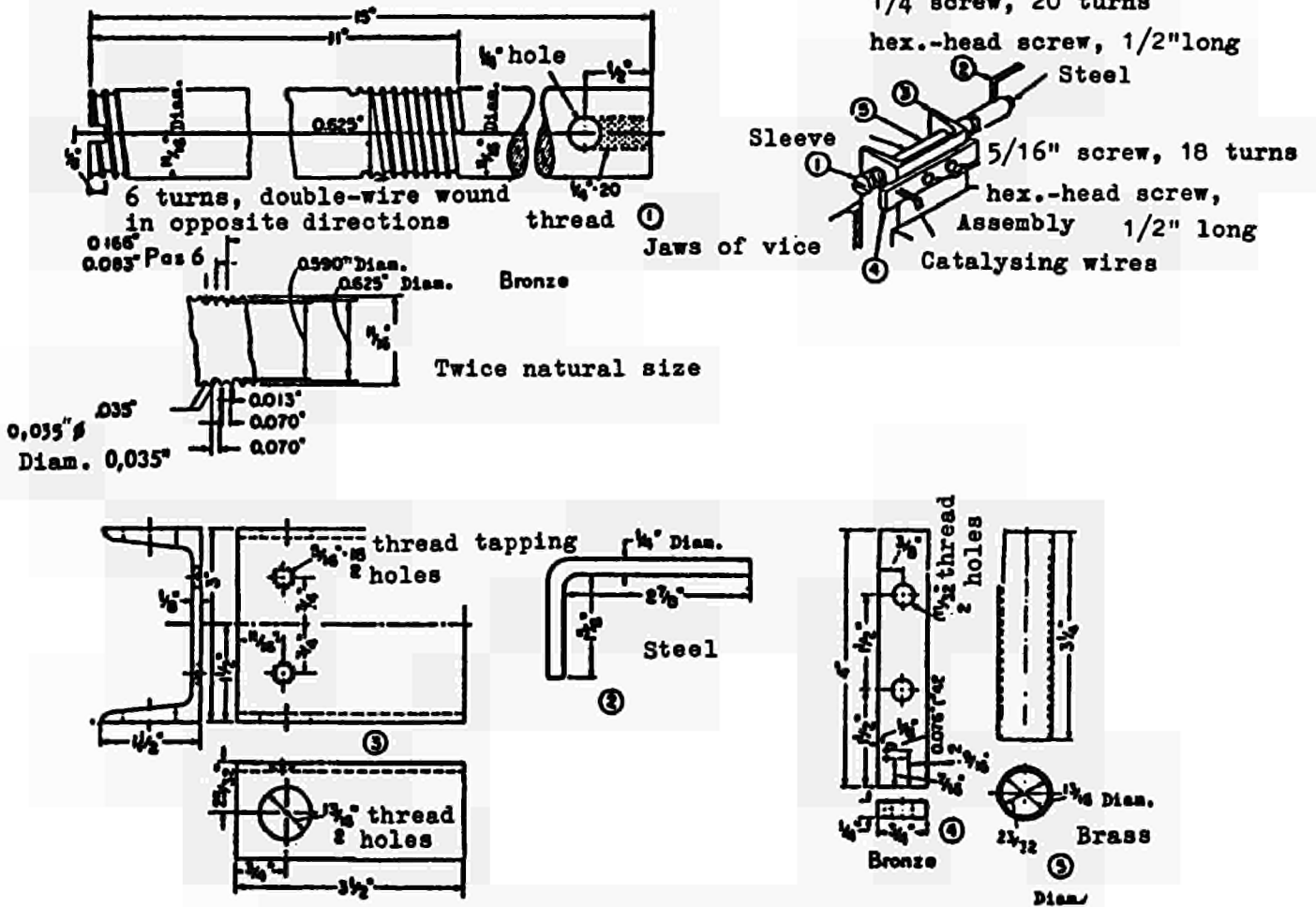

Fig. 2: SPINDLE FOR WINDING CATALYZING COILS



ANNEX X (B)DETERMINATION OF THE RESISTANCE TO AGEING OF WATER-CONTAINING FLUIDSREMARKS

The method uses the apparatus and applies the ageing conditions laid down by method ASTM D 943-54. The apparatus, the determination of ageing and the examination of the aged samples have been modified to suit the application to water-containing fluids.

1. RANGE OF APPLICATION

This method serves to determine the characteristics of resistance to ageing of water-containing fluids used in hydraulic systems.

2. PRINCIPLE

The test fluid is subjected to a temperature of 95°C, in the presence of oxygen and after the addition of iron and copper as catalysts.

3. APPARATUS AND REAGENTS

## a) Oxidizing cell (fig. 1).

The cooling jacket of the oxidizing cell differs from that described in Annex X (A) in that its envelope is not 100 mm, but 200 mm long (fig. 1).

b) A thermostatically-controlled and adjustable heating bath which maintains the fluid in the oxidizing cell at a temperature of  $95 \pm 0.2^\circ\text{C}$ , provided with a stirring device to ensure that the temperature of the bath is uniform throughout. (The dimensions of the bath must be such that the required number of oxidizing cells can be completely surrounded by the fluid in the bath to a height of 350 mm.)c) Flow-meter with minimum capacity of 3 litres/hour and an accuracy of  $\pm 0.1$  litre/h.

## d) A device for winding the catalyzing coils (fig. 2).

## e) Thermometer graduated from 75 to 125°C.

## f) A catalyst consisting of a low-alloy steel wire, No. 16, made by Washburn and Moen (low-alloy steel wire, material type A, specification ASTM A 129, 1st part, ASTM Standards 1955, for open steel electric heating-plates of ordinary quality), the wire being 1.59 mm in diameter, together with a wire of electrolytic copper, No. 14, made by the American Wire Company, the wire being 1.625 mm in diameter.

g) Hydrochloric acid, concentrated industrial grade ( $\gamma = 1.18$ ).

## h) Hydrofluoric acid, concentrated industrial grade (approx. 50 %).

## i) Ordinary petrol, boiling range 65° to 95°C.

- j) Nitric acid, concentrated industrial grade ( $\gamma = 1.42$ ).
- k) Oxygen in a container with a pressure regulator. It is advisable to use an oxygen bottle with a two-step regulator.

#### 4. PREPARATION OF THE APPARATUS

##### a) Cleaning the catalyst

On the day fixed for the start of the test, 3 m of steel wire and 3 m of copper wire are cleaned with cotton wool soaked in normal petrol; the surface of the wire is then polished with emery paper No. 100 (OO). Any traces of metal or emery are then wiped off with dry cotton waste. In all subsequent operations, the wire should be handled with cotton cloth or cotton gloves to avoid contact with the operator's skin.

##### b) Preparation of the coils

The two wires are firmly joined at one end by making six turns, and then wound on a threaded spindle. The free ends of the steel wire and copper wire are then also attached by six turns; the coils are removed from the spindle, and then reduced in length until the top edge of the coils - when slid over the oxygen-inlet pipe - stands 13 mm below the boundary surface of the water, before the latter has been poured in.

This fixed length makes it possible to take samples periodically from inside the oxidizing cell for analyses purposes, without materially changing the ratio of the volumes to be examined with respect to the active surface area of the catalyst.

##### c) Cleaning the oxidizing cell

The inlet tubes and reaction vessels are cleaned by rinsing with acetone, with tap water, chromo-sulphuric acid and again tap water, until the latter contains no more acid. The objects are then twice rinsed with small quantities of acetone and three times with distilled water. Finally, the reaction vessel is filled with distilled water, the oxygen inlet-pipe is put in place, together with the cooling jacket, and the whole assembly is left in this condition for 24 hours before beginning the test. Shortly before the test begins, the vessels are emptied and dried, and the outer walls of the inlet-pipe and the cooling jacket dried with cotton waste.

##### d) Cleaning the vessels after use

After use the reaction vessels should be washed with normal petrol and wiped with a long-handled brush. This cleaning process is repeated with acetone replacing the petrol, after which the tubes are filled with oxidizing mixture composed of three parts of HCl and one part of HNO<sub>3</sub> which is left in the apparatus for at least 24 hours at room temperature. The apparatus is then rinsed with tap water to remove all traces of acid and the organic reaction products are removed by means of acetone. If a ring-shaped mark remains in the interior of the vessel, it should be rinsed with a mixture of equal parts of hydrofluoric acid and hydrochloric acid. This mixture of acids should be left in the vessel until the ring-shaped mark disappears or dissolves, and the acid is then rinsed away with large quantities of tap water. The final cleaning is then carried out as in paragraph c).

#### 5. ANALYSIS PROCEDURE

- a) The bath is heated to a temperature sufficiently high to ensure that the test fluid, contained in the required number of reaction vessels, reaches the prescribed temperature of  $95^{\circ} \pm 0.2^{\circ}\text{C}$ .



- b) The catalyzing coils are then slid over the inlet orifice of the oxygen-inlet pipe and coils are centred. A quantity of 360 ml of test fluid is poured on to the coils until they are completely wetted. The reaction vessel is then immersed in the heating bath in such a way that the fluid in the bath stands at least 75 mm above the surface of the test fluid. The cooling jacket is then pushed on the inlet pipe and connected to the cooling water supply (the temperature of the cooling water must not exceed 35°C during the test).
- c) The oxygen-inlet pipe is connected to the oxygen bottle via the flow-meter, the quantity of gas being adjusted to  $3 \pm 0.5$  litres/hour, and the flow of gas is allowed to continue for 30 minutes. The time is recorded. It is necessary to adjust the volume of oxygen at least twice a day to comply with the prescribed tolerances.
- d) At least three hours before the beginning of the test the temperature of the mixture in the reaction vessel must be checked every hour until the temperature measured on two successive occasions is constant at  $95^\circ \pm 0.2^\circ\text{C}$ . Thereafter it is necessary to check once a day that the bath temperature remains constant over the entire test period.
- e) By constantly topping-up with distilled water the level of fluid in the oxidizing cell is maintained in spite of evaporation losses.

In certain conditions, because of deposits or the formation of emulsions, the fluid cannot easily be inspected. For this reason it is necessary to mark the fluid level before the test begins. If test samples are removed from the cell, the total reduced volume obtained in this way is marked and the volume of water maintained exactly to this mark, if necessary by adding fresh sample material.

## 6. ANALYTICAL DETERMINATION OF THE AGEING PROCESS

- a) During the ageing process, a sample is taken roughly every 2 days from the centre of the fluid in the reaction vessel, the quantity being about 10 ml for analysis, after stopping the oxygen supply.
- b) The 10 ml sample is divided into two parts, one part (approx. 5g) being used to determine the neutralization and pH values, the remainder to determine the insoluble substances (deposition of sludge). The determination of these waste substances is restricted to group C fluids and cannot be applied to emulsions.
- c) Determination of the neutralization value

If it is not possible to determine the neutralization value by the normal commercial method using alkali blue as a colour indicator, the value must be determined potentiometrically. In this case, either the total acid number (TAN) or the total base number (TBN) must be determined as laid down in method ASTM D 664-54.

The pH value is measured by means of a compound alkaline-resistant glass electrode.

- d) Determination of the content of insoluble matter

Approximately 5 g of the fluid are filtered under slight vacuum using a previously-weighed membrane filter (type: average pore diameter 0.4 microns, filter diameter 40 mm). Care must be taken to ensure that the filter is not subjected to dry suction because this blocks the pores. The filter is then washed with distilled water until the filtrate is completely clear.

The membrane filter is then placed in a desiccator for one hour, after which it is weighed. It is advisable to carry out a blank filter test with distilled water, and determine the variation in weight.

- e) The duration of the test must be at least 200 hours of ageing. Once the ageing is finished, other tests of very different kinds can be carried out if this is desired.



- (a) -

ANNEX X (B)

METHOD FOR DETERMINING THE RESISTANCE TO AGEING OF  
WATER-CONTAINING FLUIDS

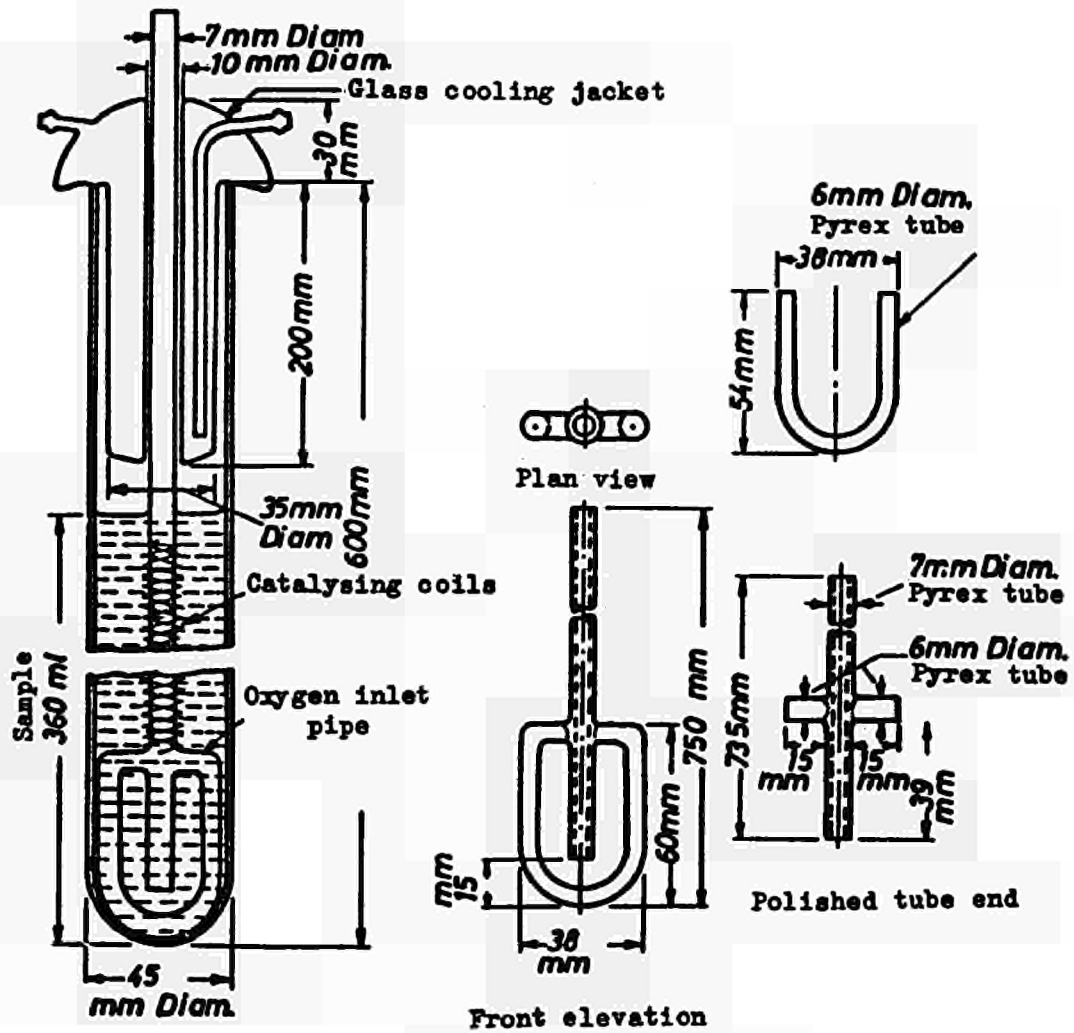

Fig. 1: OXIDIZING CELL



-(b)-

ANNEX X (B)

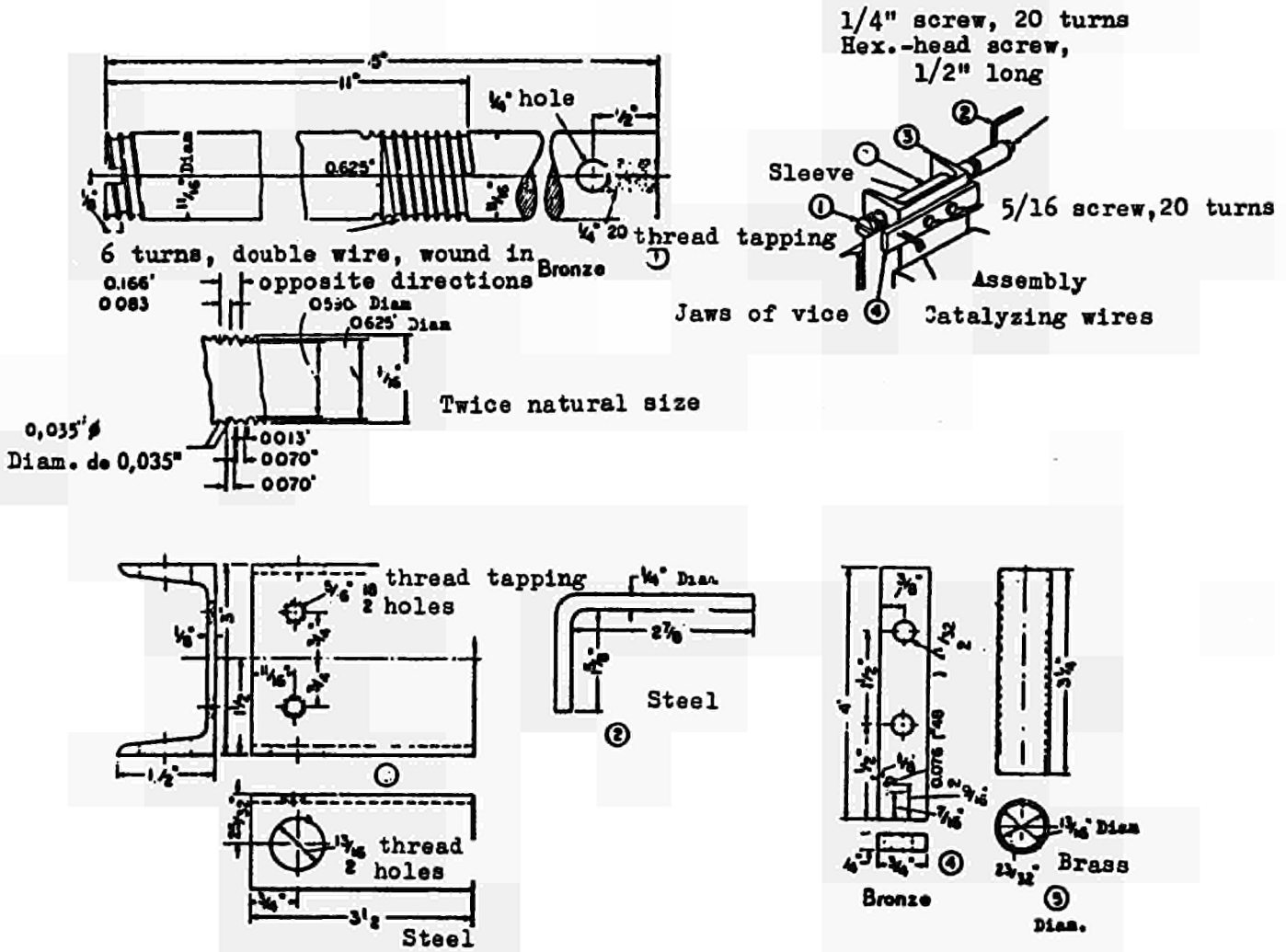

Fig. 2: SPINDLE FOR WINDING CATALYZING COILS



ANNEX XIDETERMINATION OF THE RESISTANCE TO SWELLING OF PACKINGS AND SEALS1. APPLICATION

This method is used to determine the behaviour of packing and sealing materials in contact with fire-resistant fluids of groups A, B, C and D at a test temperature of 70°C. Group D fluids should also be tested at 150°C.

2. PRINCIPLE

Sample pieces of the packing material are suspended in the test fluid under clearly-defined conditions. The volume and Shore hardness are measured before and after the test.

3. APPARATUS

- a) Glass beakers 250 ml capacity (tall type)
- b) Erlenmeyer flasks, 500 ml capacity
- c) Bowl-condenser (jacket length 250 mm)
- d) A thermostatically-controlled and adjustable bath for a bath temperature of  $70^{\circ} \pm 1^{\circ}\text{C}$  or  $150^{\circ}\text{C}$ . The dimensions of the bath must be such that at least 2 beakers or Erlenmeyer flasks can be surrounded to a depth of 70 mm by the bath fluid.
- e) Balance
- f) Shore-hardness apparatus A with scale divisions in steps of 5 hardness units, from 0 to 100 (0 being the lowest hardness, and 100 the highest). The indentation body consists of truncated cone. The apparatus conform to the requirements of ASTM D 676 - 55 T.

4. TEST PROCEDURE

Circular sample pieces of the packing material, 40 mm in diameter and 6 mm thick, are cut out. Two samples for each material quality are made for each test.

The samples are cleaned with a rag dipped in anhydric alcohol. The sample volume is determined by weighing them, first in atmosphere and then under water. The samples are then dried and brought up to a temperature of  $20 \pm 2^{\circ}\text{C}$  before tested for Shore hardness.

This test is made at three different points. The measuring points must be  $\geq 5$  mm apart and  $\geq 13$  mm away from the sample edges. The Shore-hardness apparatus is brought down, with the indentation point and the bearing surface surrounding it, until it bears closely on the test piece. The hardness value is read off from the scale after 3 seconds contact.

For group D fire-resistant fluids, a sufficient quantity of fluid is poured into the beaker to give a ratio of 1:15 between the sample-piece volume and the fluid volume (5 g of sample require some 100 ml of fluid).

For groups A, B and C fire-resistant fluids, the beaker is replaced by an Erlenmeyer flask, as otherwise too much fluid evaporates during the test period. Once the sample piece has been placed in the fluid, a water-cooled bowl condenser is set over the Erlenmeyer flask.

If required, the Erlenmeyer flask and the condenser can be used instead of the glass beaker for group D fluids.

The beaker of Erlenmeyer is then kept for a consecutive period of 168 hours (7 days) at a temperature of  $70^{\circ}\text{C} \pm 1^{\circ}\text{C}$ , or  $150^{\circ}\text{C} \pm 2^{\circ}\text{C}$ . The sample pieces are then cleaned with anhydric alcohol and dried between two filter papers. Five minutes drying the volume and Shore-hardness of each sample must be determined, as described above.

## 5. REPORTING THE TEST RESULTS

The proportional increase in volume - which is taken as the swelling index - can be arrived at by the following formula:

$$V = \frac{V_2 - V_1}{V_1} \times 100$$

in which:

V = proportional increase in volume of the sample,

$V_1$  = volume of the sample before immersion,

$V_2$  = volume of the sample after immersion.

If the different values deviate by more than 1 % (in absolute figures) from the average value, the test should be repeated.

The measurements of values obtained for the Shore hardness must be expressed in integral hardness units. The change in Shore hardness is calculated by the following formula:

$$H = H_1 - H_2$$

in which:

H = difference between Shore hardness before and after immersion,

$H_1$  = Shore hardness before immersion,

$H_2$  = Shore hardness after immersion.

The different values must not deviate by more than 2 Shore hardness units from the average value.



ANNEX XIIDETERMINATION OF PROTECTION AGAINST WEAR1. APPLICATION

This method is used to determine the capacity of a fluid to give protection against wear by comparing it with the protection against wear given by a standard fluid defined as in 7 d).

Under the term "protection against wear" of a fluid we are to understand the capacity of the fluid to maintain the elements of a machine in good running order, without losses of power or abnormal wear attributable to friction; the loadbearing capacity of the film of fluid is an index of the protection against wear.

2. PRINCIPLE

A sample of fluid is subjected to a series of tests of a fixed duration, in the four-ball apparatus, under loads increasing to seizure point. The protection against wear properties is expressed by two figures:

- a) average Hertz load, or corrected average load
- b) seizure load

3. APPARATUS

- a) Four-ball apparatus (Royal Dutch-Shell model) calibrated in accordance with the instructions published by Shell Refining and Marketing Co. Ltd. (London).
- b) Binocular magnifier for measuring the test indentations on the samples, with a minimum magnification of 15 x - 20 x, and with micrometer adjustment. The micrometer adjustment is calibrated by means of a suitably set micrometer scale. It is particularly recommended to use a special object-slide having a hemispherical scale 13 mm in diameter.
- c) Test piece: Steel ball-bearings, 12.7 mm diameter III, in material 105 Cr 2(W 1), hardness 64 + 2 HRC, made by the SKF Company of Schweinfurt.
- d) Stopwatch with 0.1 sec. scale division.

4. CLEANING AGENTS

- a) The solvents used to clean the sample pieces must not exhibit any special high-pressure behaviour, a provision which eliminates such substances as carbon tetrachloride. Use should be made either of a completely evaporating petroleum distillate (e.g., petroleum ether or heptane) or else crystallizable benzene (C<sub>6</sub>H<sub>6</sub>).
- b) The solvents for the ball race, the double-core centring device and the rotating lining vary according to the type of fluid under test. For these solvents there are no restrictions as to any possible high-pressure characteristics.

With petroleum oils, use should be made of either a light petroleum distillate (e.g., petroleum ether or heptane) or crystallizable benzene.

With A and B group emulsions, crystallizable benzene or petrol should be used first, followed by pure ethyl or methyl alcohol.

With group C substances careful rinsing with water is followed by the use of ethyl or methyl alcohol (minimum 95 %).

With group D substances, the best solvent must be sought, especially among such substances as monochlorobenzene, trichlorethylene, carbon disulphide, ethyl or methyl alcohol (minimum 95 %) and crystallizable benzene.

## 5. PREPARATIONS FOR THE TEST

### a) Cleaning the balls

A new set of four balls is needed for each test; they are cleaned with one of the solvents listed in 4 a) above.

### b) Cleaning the apparatus

The ball race, the double-cone centring device and the rotating liner which receives the rotating ball must be cleaned using one of the solvents listed in 4 b) above, paying attention to the type of fluid under test, and dried before assembly of the apparatus.

During successive tests on one type of fluid, it is sufficient to empty the ball race without cleaning it with a solvent. It is, however, recommended to dry all the components with a clean, dry rag before the next test begins. Complete cleaning must be carried out after each series of tests on a given fluid.

### c) Assembly

A new ball (bearing ball) is placed by hand in the rotary lining, which is then set in the lining holder and locked.

Three similar balls are placed in the race, and centred by setting the double-cone in place. The whole assembly is locked by tightening the bolt running in the outer thread of the ball-race.

The test fluid is poured into the dish, so as to cover the top surfaces of the balls to a depth of some 3 mm.

This entire assembly is then placed beneath the rotating ball and centred there by means of the support plate. The lever carrying the weights is released. This causes the stationary balls to press from below on to the rotating ball, under the effect of the test load.

### d) Changing the test fluid

In the case of low loading (up to 40 kg) or with petroleum oils or fluids containing no water, it is not absolutely necessary to change the test fluid for each of the successive loadings.

With group A and B emulsions, and with group C fluids, it is however preferable to change the total quantity of test fluid for each new loading, because water evaporation may occur to an appreciable extent.

If loadings of 40 kg are exceeded, all the test fluid must be changed after each test, care being taken to cool the ball-race down to laboratory temperature.

## 6. TEST PROCEDURE

### a) Method

For each loading selected, one three-minute test is carried out.

The test begins at a loading of 12 kg. Succeeding loadings are raised by:

- aa) steps of 6 kg up to 42 kg
- bb) steps of 10 kg from 50 kg up to the seizing load.

### b) Seizing load

Seizure will occur in a period of from about 2 to 30 seconds. If it is observed within 2 seconds, a check test must be carried out at the same loading, which is then taken to be the seizure load.

If seizure is only observed after a longer period, then, to obtain seizure within 2 seconds, a test must be carried out with a loading 10 kg higher than the previous one, assuming that the latter was below 400 kg. The new loading must be 20 kg higher if the first was above 400 kg. The seizing will be that loading causing seizure inside some 2 seconds.

### c) Measuring the wear indentations

The wear indentations formed on each of the individual balls are measured in two mutually perpendicular directions, one parallel to the scratches on the pressure surface. The wear diameter is taken as the arithmetic means of six measurements of the wear on a set of three balls.

## 7. PRESENTATION OF THE TEST RESULTS

### a) Corrected load

For each test loading, a corrected load is calculated using the following formula:

$$P_c = P \times \frac{d_H}{d}$$

$P_c$  = corrected load (in kg)

$P$  = test load (in kg)

$d_H$  = diameter of the wear indentation (in mm) measured on the Hertz line for a loading of  $P$  kg

$d$  = diameter of indentation measured on the balls (in mm)

Table I shows the values for the product  $P \times d_H$  for the various possible test loadings.

### b) Corrected average load

The corrected average load is obtained from the arithmetic mean of the corrected loads calculated for each separate loading, with the exception of the seizing load.

### c) Protection against wear

This is expressed by two loadings:

- a) The corrected average load
- b) The seizing load

d) Standard fluid

The selected standard fluid consists of a mixture of two paraffin-based petroleum oils with the following viscosity figures:

48.8 centistokes at +50°C  
9 centistokes at +100°C

The mixture comprises two oils:

free-running	27 centistokes at +50°C
viscous	236 centistokes at +50°C

A wear curve recorded for this standard fluid is included in the figure.

Appendices

- I. Table showing the values of the factor  $P \times d_H$  for the various possible test loads
- II. Correction of the diameter  $d_H$  on the Hertz line (extract from U.S. Federal Standard Method, 791):

The  $d_H$  diameter is calculated by means of the formula derived by Hertz to determine the diameter of a contact surface between two spherical surfaces. The diameter of the part statically indented in the process of deformation of the balls under the indicated load is given by the following formula:

$$d_H = 0.0873 \sqrt[3]{P}, \text{ in which:}$$

$P$  = test load applied in vertical direction (in kg)

$d_H$  = Hertz diameter (in mm).

ANNEX XIITABLE IVALUES OF THE FACTOR  $P \times d_H$ 

Load P (in kg)	Hertz diam- eter $d_H$ (in mm)	Correc- tion factor $P \times d_H$	Load P (in kg)	Hertz diam- eter $d_H$ (in mm)	Correc- tion factor $P \times d_H$	Load P (in kg)	Hertz diam- eter $d_H$ (in mm)	Correc- tion factor $P \times d_H$
10	0.188	1.880	190	0.502	95.380	400	0.643	257.200
12	0.200	2.400	200	0.511	102.200	420	0.654	274.680
18	0.229	4.122	210	0.519	108.990	440	0.664	292.160
24	0.252	6.048	220	0.527	115.940	460	0.674	310.040
30	0.271	8.130	230	0.535	123.050	480	0.684	328.320
36	0.288	10.368	240	0.543	130.320	500	0.693	346.500
40	0.299	11.942						
42	0.303	12.726	250	0.550	137.500	520	0.702	365.040
50	0.322	16.100	260	0.557	144.820	540	0.711	383.940
60	0.342	20.520	270	0.564	152.280	560	0.720	403.200
70	0.360	25.200	280	0.571	159.880	580	0.728	422.240
80	0.376	30.080	290	0.578	167.620	600	0.736	441.600
90	0.391	35.190	300	0.584	175.200	620	0.744	461.280
100	0.405	40.500	310	0.591	183.210	640	0.752	481.900
110	0.418	45.980	320	0.597	191.040	660	0.760	501.600
120	0.431	51.720	330	0.603	198.990	680	0.768	522.240
130	0.442	57.460	340	0.609	207.060	700	0.775	542.500
140	0.453	63.420	350	0.615	215.250	720	0.783	563.760
150	0.464	69.600	360	0.621	223.560	740	0.790	584.600
160	0.474	75.840	370	0.627	231.990	760	0.797	605.720
170	0.484	82.280	380	0.632	240.160	780	0.804	627.120
180	0.493	88.740	390	0.638	248.820	800	0.810	648.000



- (a) -

DETERMINATION OF PROTECTION AGAINST WEAR

ANNEX XII

4-Ball apparatus  
Scale 1:1

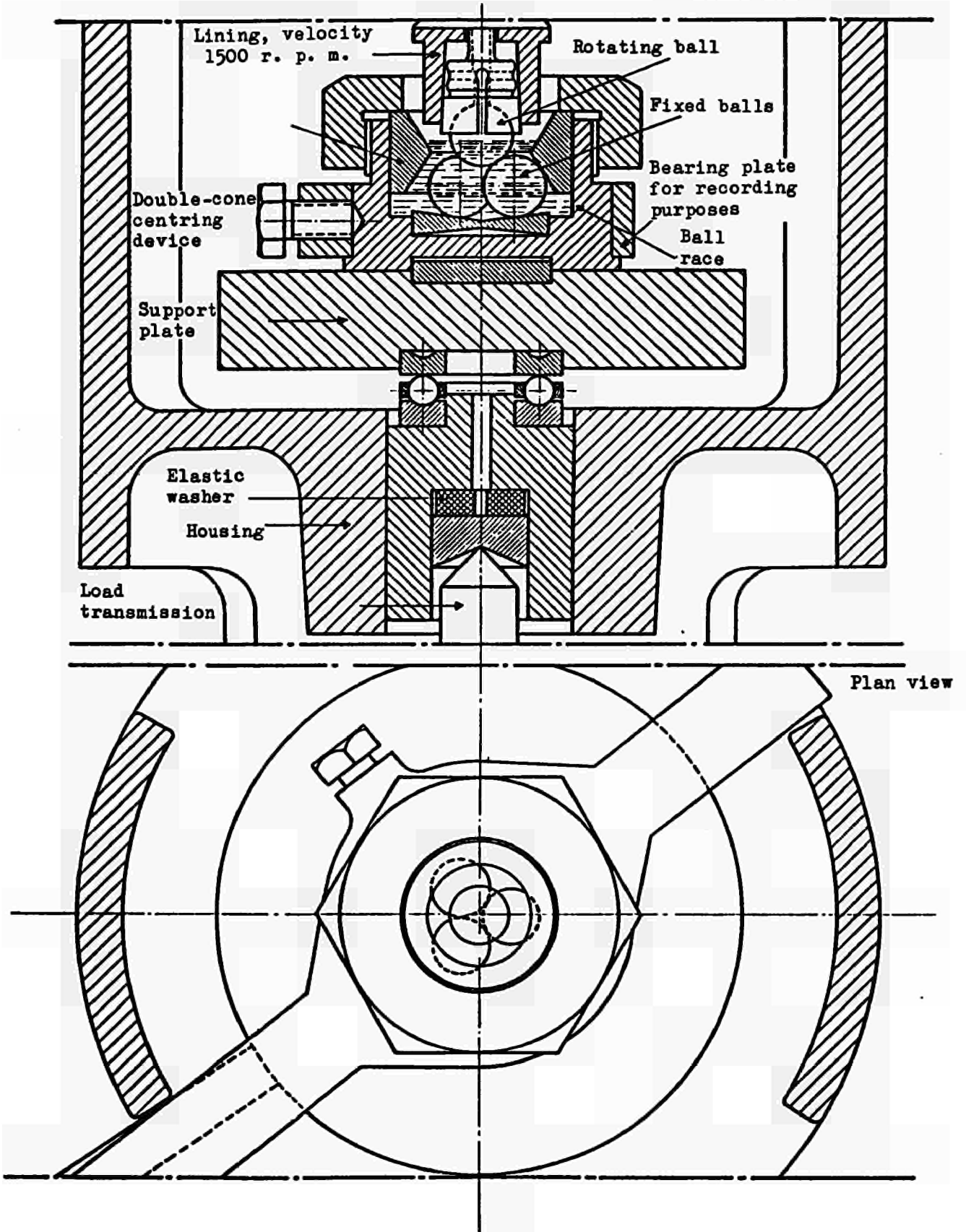





- (b) -

ANNEX XII

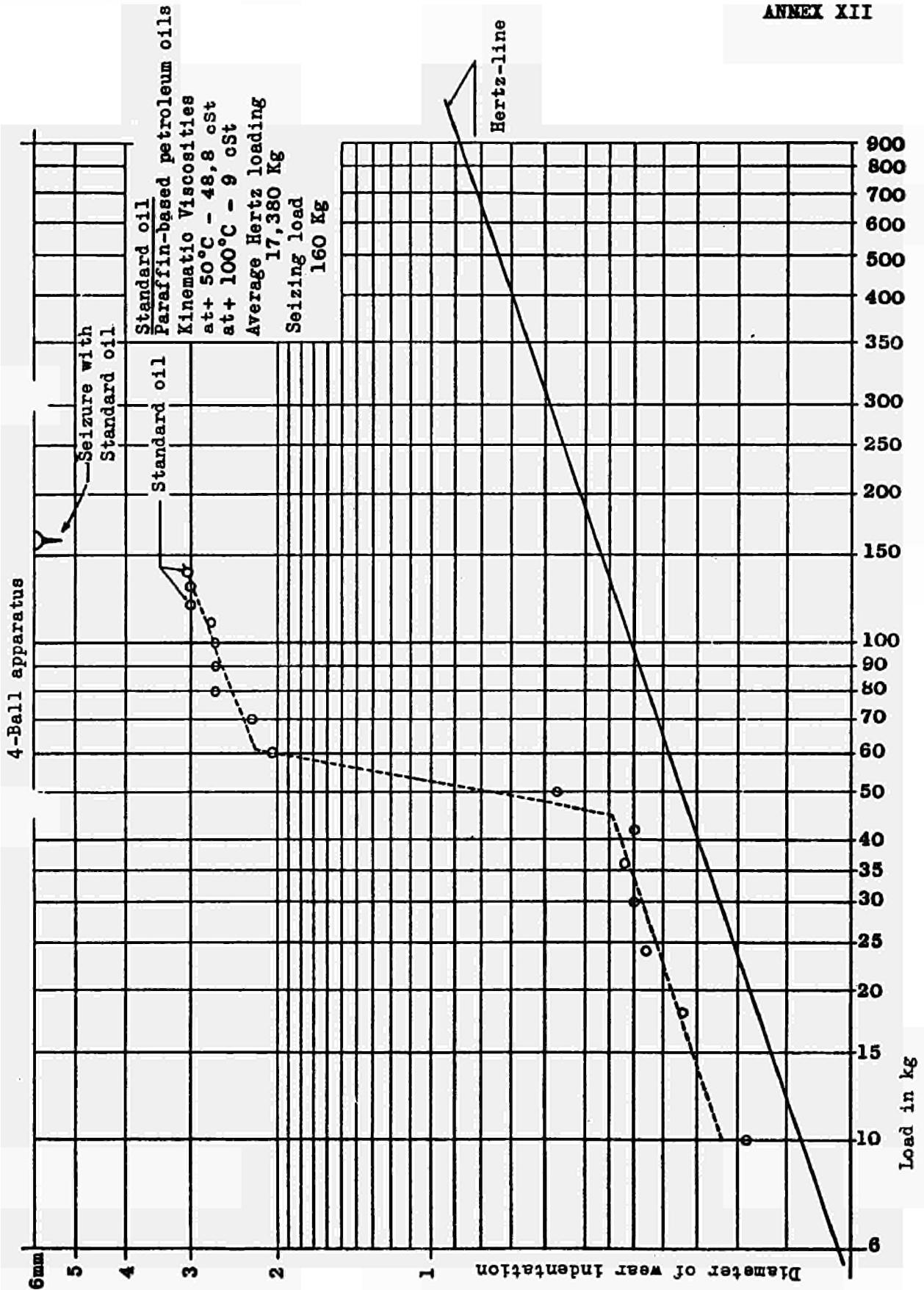



ANNEX XIIIDETERMINATION OF TENDENCY TO FOAM FORMATION

(Extract from standard ASTM D 892-58 T)

1. APPLICATION

Fluids with or without addition of water (groups A, B, C and D).

2. PRINCIPLE

A finely-diffused current of air is led into the fluid at different temperatures and the volume of foam resulting is then measured.

3. APPARATUS

## a) 1,000 ml measuring cylinder

The graduated scale for 1,000 ml must cover 365 mm  $\pm$  15 mm.

## b) Air-inlet tube with diffusion plug of alundum (Norton Company, Refract. Division, Worcester, 6, Mass., U.S.A. Designation No. ME-46239, Grade: fine).

The air-inlet tube is made of brass and is at least 450 mm long. The diffusion plug, which is spherical, porous and made of sintered aluminium oxide, and 25 mm in diameter, is fixed to the lower end of the inlet tube.

c) A thermostatically-controlled bath, consisting of a glass vessel filled with water, provided with a heating device, automatic temperature control and a stirrer. The glass vessel should be big enough to allow the measuring cylinder to be immersed up to the 900 ml mark. The temperature of the heating bath must be adjustable to  $25^{\circ}\text{C} \pm 0.5^{\circ}\text{C}$  or  $95^{\circ}\text{C} \pm 0.5^{\circ}\text{C}$ .

## d) Flowmeter to provide adjustment of the prescribed flow of air:

The types used are either the normal Rotameter or the fluid-filled U-tube type of flowmeter which indicates the pressure difference upstream and downstream of a capillary tube inserted in the air current. (It is advisable to have a capillary-like construction at the bottom point of the U-tube to damp oscillations of the fluid caused by pressure variations.)

## e) Stopwatch.

f) Thermometer: precision thermometer 0 to  $100^{\circ}\text{C}$ , with scale divided in  $0.2^{\circ}\text{C}$ .4. CHEMICAL REAGENTS

## a) Petroleum ether or heptane

## b) Chemically pure acetone

## c) Pure benzene.

## 5. PREPARATIONS FOR THE TEST

- a) To eliminate all the fluid residues from previous tests, which might in certain circumstances falsify the results, the apparatus coming into contact with the sample must be thoroughly cleaned.

This is especially the case for:

- aa) the measuring cylinder: this must be carefully washed out with petroleum ether or heptane, then with acetone and finally with distilled water, after which it is dried with dry, clean (oil-free) air;
- bb) the diffusion plug in the air-inlet tube: the plug is cleaned successively with petroleum ether or heptane, benzene and finally with a fresh quantity of petroleum ether or heptane, by dipping it into the three solvents - some 300 ml of solvent being used each time - and the solvent aspirated by vacuum and expelled again by air pressure (each operation being repeated 5 times). Tube and plug are then dried with dry, clean (oil-free) air. The pipe is finally wiped with a clean, dry cloth.
- b) The air-inlet tube is then introduced into one orifice of a rubber cork pierced by two holes, which seals the measuring cylinder, the tube being so inserted that the diffusion plug just touches the bottom of the measuring cylinder.
- c) Then some 200 ml of the sample are heated to  $50^{\circ} \pm 2^{\circ}\text{C}$  in a clean glass vessel and then cooled to  $25^{\circ} \pm 2^{\circ}\text{C}$ . In addition, the heating bath is adjusted to  $25^{\circ}\text{C} \pm 0.5^{\circ}\text{C}$ . The measuring cylinder is filled up to the 190 ml mark with the prepared sample, and then placed in the heating bath in such a way that the water reaches at least the 900 ml mark.

## 6. TEST PROCEDURE

- a) Once the fluid in the measuring cylinder has reached the temperature of the bath, the rubber cork carrying the air-inlet tube is placed on the measuring cylinder (the diffusion plug just touching the bottom of the cylinder) and a period of 5 minutes is allowed to elapse for the plug to become saturated with fluid. During this operation, the air supply must not be connected. The tube is then connected to the air supply and a flow of air of  $94 \text{ ml} \pm 5 \text{ ml}$  per minute introduced. (The air must be dry and oil-free. If necessary, one or more tubes containing calcium chloride and activated carbon together with another tube filled with cotton wool should be placed in the air line.) When a period of 5 minutes + 10 seconds has elapsed after the appearance of the first air bubbles on the surface of the diffusion plug, the flow of air is cut off and the volume of foam formed immediately measured, and expressed in milliliters. The term volume of foam should be understood as referring to the volume between the upper edge (average value) of the layer of foam and the surface of the fluid below this.

Without removing the air inlet, the measuring cylinder is left for a further 10 minutes + 10 seconds in the water bath, after which the foam volume is measured again.

- b) For a similar test carried out at  $95^{\circ}\text{C}$ , the preparations are identical with those described in section 5 above, but the bath is heated to  $95^{\circ}\text{C} \pm 0.5^{\circ}\text{C}$ .

A freshly-cleaned air-inlet tube and diffusion plug should be used for the introduction of the air.

The measurement is carried out as in section 6 a) above, after the necessary lapse of time for bubble formation or settlement.

- c) The foam remaining after the test described in section 6 b) is then broken up by light stirring. The fluid is cooled to below  $40^{\circ}\text{C}$ , by allowing the measuring cylinder to stand open to the air at room temperature. Once the fluid has reached the

heating-bath temperature of  $25^{\circ} \pm 0.5^{\circ}\text{C}$ , a freshly-cleaned air-inlet tube and diffusion plug are inserted. Then the process described in section 6 a) is repeated and the foam volume measured after the lapse of time for bubble formation or settlement.

#### 7. PRESENTATION OF RESULTS

Temperature of the sample of fluid	Volume of foam measured immediately after air introduction	Foam volume after 10 minutes
25°C	..... ml	..... ml
95°C	..... ml	..... ml
25°C (after determination at 95°C)	..... ml	..... ml



ANNEX XIVDETERMINATION OF EMULSION STABILITY1. PRINCIPLE

To check that the emulsion when ready for use is stable when stored at the two temperatures +20°C, +40°C.

2. APPARATUS

- Two cylindrical test tubes each of some 250 ml capacity, with ground stoppers; these tubes should be approximately 40 mm in external diameter and have a height of 240 mm, up to the 250 ml mark.
- Thermostats for temperatures of +20 and +40°C  $\pm$  1°C.

3. TEST PROCEDUREa) Sample preparation

The volume of the sample is to be approximately 600 ml.

Two cases may arise:

- aa) the emulsion is ready for use;
- bb) only a concentrate is provided, and the emulsion must be made up before use.

In the second case, the emulsion is to be made up using water of a hardness of 40  $\pm$  5 (French hardness scale (1) ), by shaking it up for at least 5 minutes.

b) Treatment

The sample is distributed equally over the two 250 ml test tubes. These are then sealed and subjected to the temperature conditions listed above, one tube in the thermostatically-controlled bath at +20°C, and one tube in the thermostatically-controlled bath at +40°C.

c) Observations

The samples are examined every 24 hours. No oil should rise to the surface after:

- 1,000 hours for emulsions of the oil-in-water type
- 600 hours for the emulsions of the water-in-oil type.

Only a creamy layer not exceeding 5 mm in thickness is permissible. No separation of water and oil is permissible.

x  
x x

---

(1) Corresponding to 22.4  $\pm$  2.5 degrees of hardness on the German hardness scale.





ANNEX XVIIDETERMINATION OF TOXICITY OF FIRE-RESISTANT HYDRAULIC FLUIDS MISCIBLE WITH  
WATER, GROUPS A AND CI. INFRA-RED SPECTROPHOTOMETRIC CHECK OF IDENTITY

A weighed sample of fluid is placed with anhydric phosphoric acid in a desiccator, heated to 70°C and left until it reaches constant weight.

The residual fluid is extracted with 10 times its volume of peroxide-free ethyl ether.

The ether collected is evaporated in a vacuum. An infra-red spectrum of the residues is taken, comprising extinction values 0 to 1.5 or transparency values of 0 to 100 % over the whole wavelength range from 3 to 15 microns.

The spectra are not analyzed but are used as identity references for the subsequent tests.

II. ORAL TOXICITY

The determination of oral toxicity (mean lethal dose LD 50) is performed on male white mice and is expressed in g/kg of body weight.

The hydraulic fluid under test (diluted with water if necessary) is fed to male white mice by way of a tube inserted through the mouth. The observation period is 14 days.

The tube is fitted like a hypodermic needle to a tuberculin syringe. The front end of the tube is blunted and thickened, to avoid injury to the animals.

Each mouse is weighed, and the quantity of fluid introduced into its stomach referred to the weight of the animal.

A first approximation test of LD 50 is carried out on a fairly small number of animals. Four of them receive a dose P. Then the next four receive a dose 2 P; further animals are given 4 P, etc. If the "first arbitrary" dose P is too high, the subsequent experiments should be performed with fractions of P.

After this first approximation test, the range of LD 50 is pretty well worked out. Tests are then carried out on groups of mice, the numbers of which are determined by the statistical certainty (limit of certainty 20 %) of the values obtained each time. Each group now receives 0.4, 0.6, 0.8, 1.0, 1.2, 1.4 times, etc., of the rough LD 50 already determined.

For each individual dose, the number of dead animals is expressed as a percentage, and the results are plotted on a logarithmic curve (probability paper). Then, the dose which causes the death of 50 % of the animals is determined graphically from the curve.

The results are classified as under:

LD 50	>	at 5 g/kg	:	0
LD 50	<	at 5 g/kg and > 50 mg/kg	:	5
LD 50	<	50 mg/kg	:	10

### III. DETERMINATION OF TOXIC EFFECT

#### A. Overall toxicity

Dilutions of fluid with a final volume of 1 litre and the following concentrations of test fluid:

$1.10^{-1}$   
 $1.10^{-2}$   
 $1.10^{-3}$   
 $1.10^{-4}$   
 $1.10^{-5}$

are made up at room temperature with tap water, each in a shallow vessel (2 litres capacity). Three goldfish (*Carassius Auratus*), weight 5 to 10 g, are placed in each vessel. Over a total period of 120 hours, the time of survival of each fish in each group is noted. If the fish die within this period, the symptoms exhibited before death are noted: haemorrhages or locomotor co-ordination disturbances.

The results are classified as under:

Survival of all the fish		0
The fish in the concentration $1.10^{-1}$ die	after more than one hour	1
	after less than one hour	2
The fish in the concentration $1.10^{-2}$ die	after more than one hour	3
	after less than one hour	4
The fish in the concentration $1.10^{-3}$ die	after more than one hour	5
	after less than one hour	6
The fish in the concentration $1.10^{-4}$ die	after more than one hour	7
	after less than one hour	8
The fish in the concentration $1.10^{-5}$ die	after more than one hour	9
	after less than one hour	10

#### B. Irritant effect

##### 1. Tests to determine the irritant effect on the eyes

Using a standard eye-dropper, a drop of test fluid is placed in the conjunctival sac of the right eye of two male albino rabbits of at least 1 kg weight. The state of the right eye and its surroundings (except the eye-lid) is examined and compared with the left eye, once a day for 5 days.

During the whole test period the animals must be isolated from the others.

Disregarding any infections, the results are classified as under:

No reaction observed	: 0
Inflammation of the eye, according to speed of development, extent and duration	: 1-5
Permanent lesions, except loss of vision	: 6-9
Loss of vision	: 10

## 2. Test to determine the irritant effect on the skin

Using the same animals as have been employed for the eye tests, the acute cutaneous irritation is investigated, by means of the "patch test", described below:

For the purposes of the tests, 24 hours before the test, the skin on the flank is shaved over an area of 8 x 8 cm, care being taken not to injure the skin surface in any way.

The patch itself consists of a piece of cotton wool 4 x 4 cm, covered by a sheet of any impermeable material which will not react with the test fluid, in such a way that direct contact with the skin is possible only over a surface of 2 x 2 cm in the middle.

After the wool has been soaked with 2 ml of the test fluid, the patch is laid on the skin and bandaged into position.

After a contact time of 24 hours, the patch is removed and the condition of the skin is examined immediately and also daily for the next 14 days.

Disregarding any infection, the results are classified as under:

No reaction observed	: 0
Erythema, according to extent and duration	: 1-3
Erythema and cutaneous oedema, not indurated	: 4
Major skin lesions (blisters, ulcers, necroses), according to extent and duration	: 5-10
Death of the animals during the test	: 10

## C. Test to determine the toxicity of aerosols

This test is carried out for group A fluids at room temperature, and for group C fluids at 70°C.

The fluid, diluted 1 : 1 with distilled water, is filled into an aerosol generator, which, fed with an air stream at 15 litres/min, emits 20 ml of the mixture per hour in aerosol form. At least 90 % of the aerosol particles must be below 3 microns in size.

The mixture so produced is fed into a 100-litre cylinder with an internal diameter of 50 cm, which rotates about its axis at the rate of 1 rpm.

Three male adult Wistar rats  $\pm$  200 g in weight are weighed and exposed to the aerosol for 3 hours. If they survive they are kept under observation for a further 14 days, after which they are weighed again.

Disregarding any infections, the results are classified as under:

No reaction observed	: 0
Symptoms of irritation (circulatory disorders, nervous affections) ceasing after	1 hour : 1 6 hours : 2 5 days : 3
Loss of weight, insufficient gain in weight	: 4
Death of one of the animals within	14 days : 5
Death of two animals within	14 days : 6
Death of three animals within	14 days : 7
Death of one of the animals during the test	: 8
Death of one animal during the test and another within 14 days	: 9

Death of two animals during the test	: 9
Death of one animal during the test and both the others within 14 days	: 10
Death of two animals during the test and the third within 14 days	: 10
Death of all three animals during the test	: 10

#### D. Thermal-decomposition products

##### 1. Procedure

The formation of thermal-decomposition products by the test fluids is carried out in a metal chamber enclosed in all sides, at one end of which the fluid is sprayed at a pressure of approximately 100 atm by means of a Diesel injector (conical spray nozzle, with a minimum spraying angle of 30 %) on to a hot plate, and at the other end of which the extraction occurs, the air-inlet orifices being roughly in the middle of the chamber. A partition between the injector and the air-inlet orifice is intended to prevent the extraction of the injected fluid before it has reached the heating plate.

The injector sprays at a rate of 0.35 to 3.5 ml of fluid per minute.

The temperature at the vaporization plate is checked by means of a thermocouple let in and can be regulated up to 700°C.

A condenser unit is connected to the extractor section of the combustion chamber and, after passing through this, the extracted mixture goes to the device where the rats are subjected to the test.

The tests are carried out at temperatures of 200° and 700°C. The output of the injector should be as near as possible to 1 ml per minute. If, with this output, the condensate amounts to 1/3 of the injected volume, a further test is carried out with the output reduced to 0.5 ml per minute.

##### 2. Toxicological examination of thermal-decomposition products

A part of the extracted gas (approximately 10 l/min) is fed into a current of fresh air in the ratio of 1 : 2. This mixture is passed through the rat cage (described in chapter C), after it has been cooled to room temperature. The further procedure follows from the information given in chapter C. The evaluation scale must apply both to the decomposition products at 200° and at 700°C.

#### E. Evaluation of the results and conditions of approval

Each product tested is given a rating between 0 and 170. This figure is obtained from the sum of the rating from each of the individual tests, after multiplication of these rating figures by the coefficients given in the following table:

Oral toxicity	LD 50	1
Irritant effect	eye	5
	skin	5
Aerosols	cold or hot	4
Toxicity to fish		2
Thermal decomposition products	200°	1
	700°	1

Any product which achieves the rating of 10 before multiplication must be rejected, as should a product reaching the total rating of 50.

ANNEX XVIIIDETERMINATION OF TOXICITY OF FIRE-RESISTANT HYDRAULIC FLUIDS NOT MISCIBLE  
WITH WATER, GROUP DI. INFRA-RED SPECTROPHOTOMETRIC CHECK OF IDENTITY

An infra-red spectrum is taken of a sample of fluid comprising extinction values 0 to 1.5 or transparency values of 0 to 100 % over the whole wavelength range from 3 to 15 microns. The spectra are not analyzed but are used as identity references for the subsequent tests.

II. ORAL TOXICITY

The determination of oral toxicity (mean lethal dose LD 50) is performed on male white mice and is expressed in g/kg of body weight.

The hydraulic fluid under test (diluted with olive oil if necessary) is fed to male white mice by way of a tube inserted through the mouth. The observation period is 14 days.

The tube is fitted like a hypodermic needle to a tuberculin syringe. The front end of the tube is blunted and thickened, to avoid injury to the animals.

Each mouse is weighed, and the quantity of fluid introduced into its stomach referred to the weight of the animal.

A first approximation test of LD 50 is carried out on a fairly small number of animals. Four of them receive a dose P. Then the next four receive a dose 2 P; further animals are given 4 P, etc. If the "first arbitrary" dose P is too high, the subsequent experiments should be performed with fractions of P.

After this first approximation test, the range of LD 50 is pretty well marked out. Tests are then carried out on groups of mice, the numbers of which are determined by the statistical certainty (limit of certainty 20 %) of the values obtained each time. Each group now receives 0.4, 0.6, 0.8, 1.0, 1.2, 1.4 times, etc., of the rough LD 50 already determined.

For each individual dose, the number of dead animals is expressed as a percentage, and the results are plotted on a logarithmic curve (probability paper). Then, the dose which causes the death of 50 % of the animals is determined graphically from the curve.

The results are classified as under:

LD 50	>	at 5 g/kg	:	0
LD 50	>	at 5 g/kg and > 50 mg/kg	:	5
LD 50	<	50 mg/kg	:	10

### III. DETERMINATION OF TOXIC EFFECT

#### A. Irritant effect

##### 1. Tests to determine the irritant effect on the eyes

Using a standard eye-dropper, a drop of test fluid is placed in the conjunctival sac of the right eye of two male albino rabbits of at least 1 kg weight. The state of the right eye and its surroundings (except the eye-lid) is examined and compared with the left eye, once a day for 5 days.

During the whole test period the animals must be isolated from the others.

Disregarding any infections, the results are classified as under:

No reaction observed	: 0
Inflammation according to speed of development, extent and duration:	1-5
Permanent lesions, except loss of vision	: 6-9
Loss of vision in the treated eye	10

##### 2. Test to determine the irritant effect on the skin

Using the same animals as have been employed for the eye tests, the acute cutaneous irritation is investigated, by means of the "patch test", described below.

For the purposes of the tests, 24 hours before the test, the skin on the flank is shaved over an area of 8 x 8 cm, care being taken not to injure the skin surface in any way. The patch itself consists of a piece of cotton wool 4 x 4 cm, covered by a sheet of any impermeable material which will not react with the test fluid, in such a way that direct contact with the skin is possible over a surface of 2 x 2 cm in the middle.

After the wool has been soaked with 2 ml of the test fluid, the patch is laid on the skin and bandaged into position.

After a contact time of 24 hours, the patch is removed and the condition of the skin is examined immediately, and also daily for the next 14 days.

Disregarding any infections, the results are classified as under:

No reaction observed	: 0
Erythema, according to extent and duration	: 1-3
Erythema and cutaneous oedema, not indurated	: 4
Major skin lesions (blisters, ulcers, necroses), according to extent and duration	: 5-10
Death of the animals during the test	: 10

#### B. Test to determine the toxicity of aerosols

##### 1. Cold aerosol

The fluid is kept at 50°C in an aerosol generator, which, fed with an air stream at 15 litres/min, emits 10 ml of the fluid per hour in aerosol form. At least 90 % of the aerosol particles must be below 3 microns in size. After passing through a Vigreux tube, this aerosol is fed into a 100-litre cylinder with a rotating diameter of 50 cm, which rotates at 1 rpm. Three male Wistar rats of the same age  $\pm$  200 g in weight are weighed and exposed to the aerosol for 3 hours. If they survive they are kept under daily observation for a further 14 days, in separate cages away from draughts; they are re-weighed at the end of the 14 days.

Three other rats of similar weight and age are kept in the same condition as controls.

Disregarding any infections, the results are classified as under:

No reaction observed	:	0
Symptoms of irritation (circulatory disorders, nervous affections) ceasing after		
	1 hour :	1
	6 hours :	2
	5 days :	3
Loss of weight, insufficient gain in weight	:	4
Death of one of the animals within	14 days :	5
Death of two animals within	14 days :	6
Death of three animals within	14 days :	7
Death of one of the animals during the test	:	8
Death of one animal during the test and another within 14 days	:	9
Death of two animals during the test	:	9
Death of one animal during the test and both the others within 14 days	:	10
Death of two animals during the test and the third within 14 days	:	10
Death of all three animals during the test	:	10

## 2. Hot aerosol

The test described above is then also carried out with fluid kept at 150°C.

Disregarding any infections, the results are classified as under:

No reaction observed	:	0
Symptoms of irritation (circulatory disorders, nervous affections) ceasing after		
	1 hour :	1
	6 hours :	2
	5 days :	3
Loss of weight, insufficient gain in weight	:	4
Death of one of the animals within	14 days :	5
Death of two animals within	14 days :	6
Death of three animals within	14 days :	7
Death of one of the animals during the test	:	8
Death of one animal during the test and another within 14 days	:	9
Death of two animals during the test	:	9
Death of one animal during the test and both the others within 14 days	:	10
Death of two animals during the test and the third within 14 days	:	10
Death of all three animals during the test	:	10

## C. Thermal-decomposition products

### 1. Procedure

The formation of thermal-decomposition products by the test fluids is carried out in a metal chamber enclosed in all sides, at one end of which the fluid is sprayed at a pressure of approximately 100 atm by means of a Diesel injector (conical spray nozzle, with a minimum spraying angle of 30 %) on to a hot plate, and at the other end of which the extraction occurs, the air-inlet orifices (approximately 10 l/min) being roughly in the middle of the chamber. A partition

between the injector and the air-inlet orifice is intended to prevent the extraction of the injected fluid before it has reached the heating plate.

The injector sprays at a rate of 0.35 to 3.5 ml of fluid/minute.

The temperature of the vaporization plate is checked by means of a thermocouple let in to it, and can be adjusted to values up to 700°C.

A condenser unit is connected to the extractor section of the combustion chamber and, after passing through this, the extracted mixture goes into the device where the rats are subjected to the test.

The test is to be carried out at temperatures of 200°C and 700°C. The output of the injector should be as near as possible to 1 ml per minute. If with this output, the condensate amounts to 1/3 of the injected volume, a further test is carried out with the output reduced to 0.5 ml per minute.

## 2. Toxicological examination of thermal-decomposition products

A part of the extracted gas (approximately 10 l/minute) is fed into a current of fresh air in the ratio of 1 : 2. This mixture is passed through the rat cage, after it has been cooled to room temperature. The remainder of the procedure follows from the information given in chapter B. 2, except for the duration of the exposure period.

The evaluation scale must apply both to the decomposition products at 200°C and at 700°C.

### D. Evaluation of the results and conditions of approval

Each product tested is given a rating between 0 and 170. This figure is obtained from the sum of the rating from each of the individual tests, after multiplication of these rating figures by the coefficients given in the following table.

Oral toxicity	LD 50	1
	Eyes	5
Irritant effect	Skin	5
	Cold	2
Aerosols	Hot	2
	200°	1
Thermal-decomposition products	700°	1

Any product which achieves the rating of 10 before multiplication must be rejected, as should a product reaching the total rating of 50.



**A P P E N D I X**

**MEMBERS OF THE GROUP OF EXPERTS**



MEMBERS OF THE GROUP OF EXPERTS "FIRE-RESISTANT HYDRAULIC FLUIDS"

TECHNICAL EXPERTS

- Dipl.-Ing. Ernst BREDEBRUCH (President)  
Leiter der Hauptstelle für das Grubenrettungswesen  
des Steinkohlenbergbauvereins  
43 E S S E N - K R A Y  
Schönscheidtstr. 28
- Guy BLANPAIN  
Ingénieur au Centre d'Etudes et Recherches des  
Charbonnages de France  
V E R N E U I L - E N - H A L A T T E/Oise  
France
- René LEFEVRE  
Ingénieur  
3, rue Louis Rolland  
M O N T R O U G E (Seine)  
France
- Dr. chem. Hans Willi THOENES  
Hauptabteilungsleiter  
Technischer Überwachungsverein e.V.  
43 E S S E N  
Steubenstr. 53
- Dipl.-Ing. Klaus GRUMBRECHT  
Abteilungsleiter  
Versuchsgrubengesellschaft mbH  
46 D O R T M U N D  
Tremoniastr. 13
- Edgard DEMELENNE  
Administrateur-Directeur  
de l'Institut National des Mines  
60, rue Grande  
P A T U R A G E S  
Belgique

Alternates

- Georges Adrien NENQUIN  
Ingénieur divisionnaire à  
l'Institut National des Mines
- Joseph BRACKE  
Ingénieur principal divisionnaire à  
l'Institut National des Mines
- Ir. VAN BLARICUM  
Staatstoezicht op de Mijnen  
Apollolaan 9  
H E E R L E N (L.)  
Nederland

MEDICAL EXPERTS

- Prof. Dr. med. MALORNY  
Direktor des Pharmakologischen Instituts der  
Universität Hamburg  
2 H A M B U R G

Alternates

- Dr. med. BENTHE  
Dozent  
Pharmakologisches Institut der  
Universität Hamburg  
2 H A M B U R G
- Dr C. CLAEYS  
Houillères du Bassin du Nord et du Pas-de-Calais  
Centre d'Etudes médicales minières  
129-133, avenue Salengro  
59 S I N - L E - N O B L E / Nord  
France
- Dr Jean-Jacques JARRY  
Médecin-Chef des Charbonnages de France  
9, avenue Percier  
75 P A R I S 8ème
- Prof. Dr. med. C.A. PRIMAVESI  
Hygiene-Institut des Ruhrgebietes  
465 G E L S E N K I R C H E N  
Rotthausenstr. 19

Alternates

- Dr. phil. H. ZIMMERMANN  
Hygiene-Institut des Ruhrgebietes
- Dr Jean CRISPOUX  
2, rue Potresse  
W A S M E S  
Belgique
- H. ITALIE, Arts  
Inspecteur der Mijnen  
Staatstoezicht op de Mijnen  
Apollolaan 9  
H E E R L E N (L.)  
Nederland

x  
x x



**PUBLICATIONS DEPARTMENT OF THE EUROPEAN COMMUNITIES**

**14 217/5/68/1**



XK1421007ENC

---

PUBLICATIONS DEPARTMENT OF THE EUROPEAN COMMUNITIES

14 217/5/68/1