

euro spectra

SCIENTIFIC
AND
TECHNICAL REVIEW
OF THE
EUROPEAN
COMMUNITIES

SEPTEMBER 1971
VOL. X
NO. 3

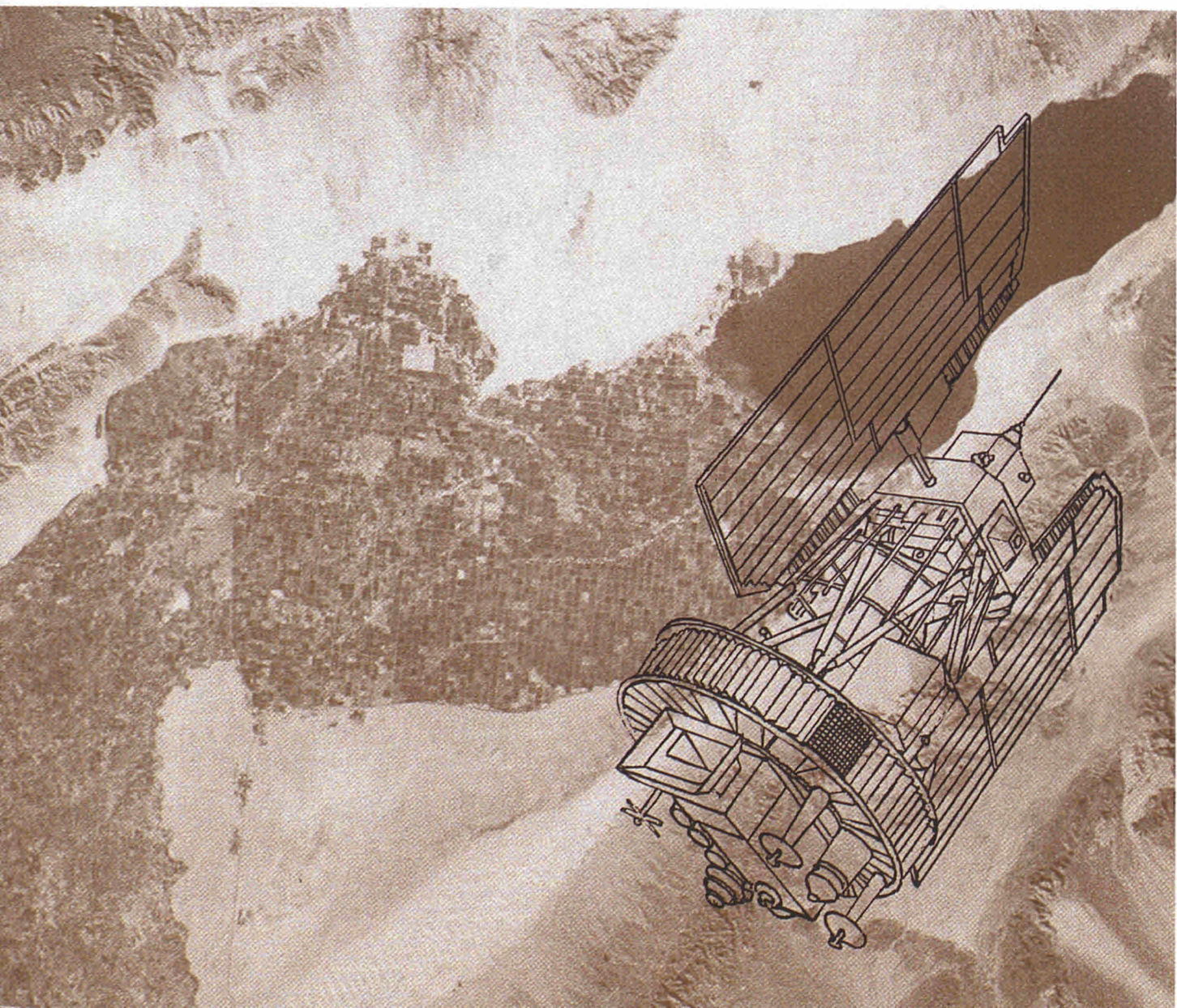



66 HARTWIG BENZLER

URANIUM ENRICHMENT

For a number of reasons the different methods of enriching uranium have lately become a focal point of interest again. This paper reviews the basic features and the foreseeable development potential of those among them which are most used.

73 PIERRE LEMOINE and GERHARD WILL

THE "BROWN FUMES"

An atmospheric pollution problem: the control of "brown fumes" in oxygen-blown steelworks.

81 CHRISTIAN GARRIC

REMOTE SENSING

A field that Europe has neglected: the observation of the earth's resources from aircraft and spacecraft.

91 GASTON GRISON

THE CREATION OF A COMMUNITY SYSTEM OF RADIO-ACTIVE WASTE DUMPS.

95

TECHNICAL NOTES

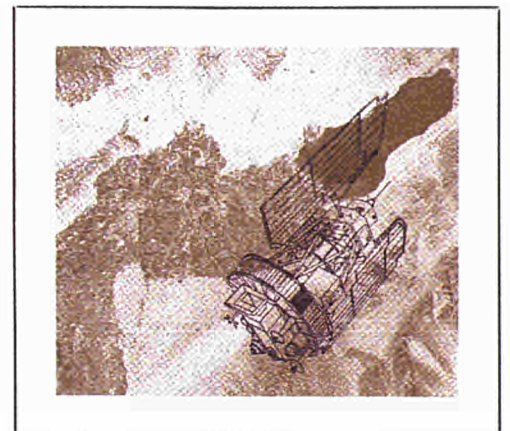



spectra

Scientific and
Technical Review
of the European
Communities
(ex-Euratom-Review)

1971 | **3**

The meetings held at Luxembourg in June 1971 will undoubtedly remain famous in history because they represented a milestone in the European Community's move towards enlargement. The excitement of this event overshadowed another, less spectacular result of a much less far-reaching political implication but one which was of a certain importance for all that. This was the creation, at the meeting of the Council of Ministers held on 24 June 1971, of what might be called the "European Information Community".

The Council adopted two resolutions. In the first, it recognised the importance to economic, scientific and technical progress of making scientific, technical, economic and social documentation data available, by the use of the most up-to-date methods, to all who need to use them, under the best possible terms as regards speed and cost. It therefore affirmed the need to promote the efforts made to this end and, for that purpose, to try to coordinate projects undertaken in the Community, so that a European documentation and information network could be gradually formed.

The Commission and the Working Party on Scientific and Technical Research Policy (PREST Group) of the Medium-term Economic Policy Committee were instructed by the Council to produce plans for bringing this network into being. They will be assisted by a new body: the Committee on Scientific and Technical Information and Documentation.

In its second resolution, the Council gave an immediate practical turn to these general principles. It decided to set up a mechanised information system for metallurgy, which would constitute the first step in the creation of the network.

These Council resolutions show that the Member States have become aware of the value of good information. In the complex present-day world there can be no question of allowing those who steer the ship, at whatever level, to trust to their intuition. In order to make their decisions on a sound basis, they need relevant and complete data.

It is again a feature of our complicated modern world that the particular information required at a given moment is so well concealed in a gigantic mass of documentation that it would be a herculean task to find it by the traditional methods. Fortunately, we possess today in the computer a powerful, disciplined, high-speed and tireless machine to do the work for us.

It would nevertheless be absurd for automated documentation systems to develop in anarchy, with all the risks of duplication and incompatibility which that would imply. It was also to combat this danger that the Community ultimately took precautions on 24 June 1971.

Lastly, the Council stated that the European network would not be sealed off hermetically, but would be wide open to cooperation outside. Are we approaching a future where it will be possible, thanks to a highly developed system, to make rapid searches in information stores at the furthest ends of the earth? This dream may yet come true.

Uranium enrichment

For a number of reasons the different methods of enriching uranium have lately become a focal point of interest again. This paper reviews the basic features and the foreseeable development potential of those among them which are most used.

HARTWIG BENZLER

A NUMBER of recent events have revived interest in the various methods of enriching uranium: the raising of enrichment charges in the United States from 26 to 32 dollars per kg separative work, the project for an enrichment plant in France using the gaseous diffusion process, with estimated costs of FFr. 3 000-3 500 million, the agreement between Germany, the Netherlands and the United Kingdom to try out the gas centrifuge process on an industrial scale, the announcement by the South African government of its intention to build a test plant for a new "unique" enrichment process with a capital outlay of 50 million rands, and the work of a special study group of the European Communities' *Advisory Committee for Nuclear Research* in the field of long-term supplies of enriched uranium.

In theory, there are numerous different ways of enriching the fraction of U^{235} , the uranium isotope which is fissionable by thermal neutrons and which occurs in the proportion of only about 0.7 % in natural uranium. Most of them were tested in the early forties, more particularly with regard to their industrial applicability, but some processes are still relatively new, e.g. isotope separation from a gas stream with a laser beam, separation by means of a rotating plasma, or the Schultz-Grunow disc separation process.

Of the various potential methods of separating uranium isotopes, the three methods which have acquired importance in connection with uranium-235

enrichment are gaseous diffusion, gas centrifuging, and nozzle separation.

Hitherto only the gaseous diffusion process has been employed on an industrial scale. The Western world's nuclear reactors obtain their enriched uranium fuel mainly from three American plants (Oak Ridge, Paducah and Portsmouth: separating capacity at full load about $17 \cdot 10^6$ kg/y). Considerably smaller gaseous diffusion plants exist at Capenhurst, in Britain, and Pierrelatte, in France. Officially, nothing is known of the isotope separation plants in the Soviet Union and China, but they probably operate on the same principle. The technical details of the gaseous diffusion plants in the Western countries have been listed as official secrets since the time of their development during the forties, so the fundamental principles of this technique have not been divulged.

During the last war the centrifuging process was used in both Germany and the United States, on a laboratory scale, to separate uranium isotopes. In the earliest stages, however, this process was judged to be of considerably lower capacity than the gaseous diffusion process, and little was done to develop it in the United States. Meanwhile, in Europe, it was chiefly certain German and Dutch groups who studied the problems of the gas centrifuge and improved its separating power. At the request of the United States, European research and development work dealing with the centrifuging process was placed on the official secrets list after 1960. Since then the development groups in the United Kingdom, the Netherlands and West Germany, working independently of one another, have successfully brought the gas centrifuge up to a certain degree of technical maturity. In the spring of 1970 the three countries decided on the joint construction of experimental uranium enrichment plants using the centrifuging process.

The nozzle separation process was developed during the last 15 years in West Germany. At the end of 1967 a 10-stage pilot plant, and in the spring of 1970 a technical separating stage with a full-load separating capacity of

HARTWIG BENZLER is a member of the Directorate-General for Industrial, technological and scientific affairs of the Commission of the European Communities.

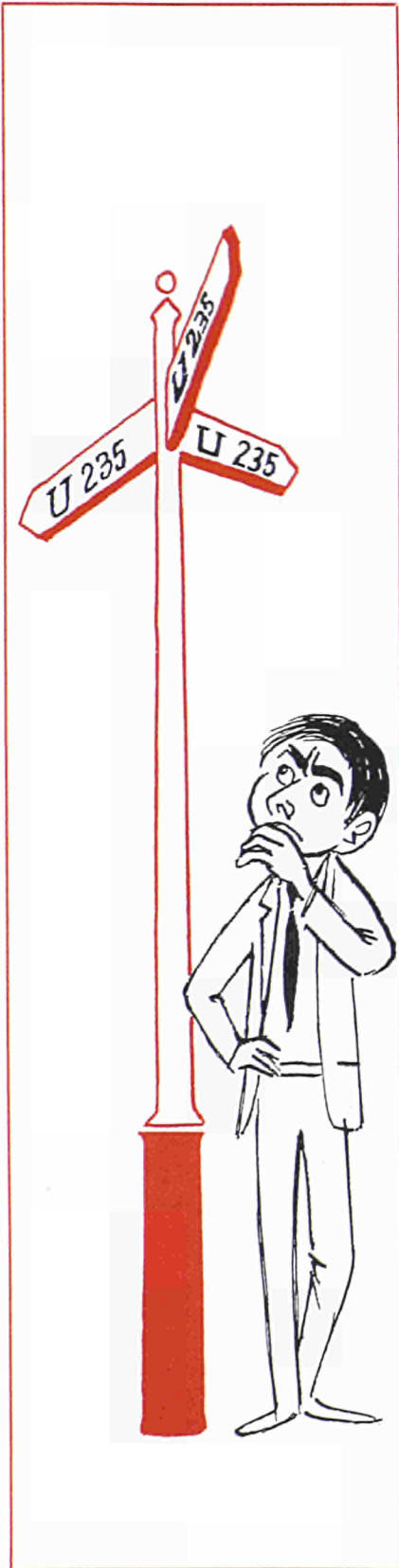

about 1 700 kg/y, went into service at Karlsruhe. Work relating to the nozzle separation process is not classified as secret, so that a certain number of recent publications have been able to provide information on the progress already achieved and expected in the future.

Gaseous diffusion

Principle—The process of separation by gaseous diffusion (or more correctly, effusion) has been described so often that details are not necessary here (see, in particular, *USAEC Report ORO-658*, pp. 3-6, 1968).

Separating capacity and specific energy consumption—The theoretical separating capacity of a stage is calculated from the amount of gas fed into the stage and an ideal separation-per-stage factor (1.00429 for uranium enrichment via UF_6).

The UF_6 compressors in a given stage, receive the enriched gas which was diffused in the preceding stage and now needs recompressing. As it leaves the compressor it is joined by an equivalent flow of gas which has not been diffused through the barriers of the next stage. Hence, for a nominal outflow from the compressor of N kg UF_6 /sec, the inflow to a diffusion stage is $2N$.

Thus on the basis of the compressor throughput of 160 kg UF_6 /sec planned in France, the theoretical separating capacity obtained is about 15 000 kg U/y per stage.

The theoretical minimum specific energy consumption, with a pressure ratio of 0.285, calculated for conventional compressor yields and working temperatures, is 1 320 kWh/kg U.

Owing to the pressure drops in the pipes and other energy losses in the plant, and taking into account the adoption of a pressure ratio of less than 0.285 and the fact that the chosen design differs from the ideal cascade, the true consumption in the gaseous diffusion process is considerably greater than the theoretical minimum value. With a plant of very modern design it is thought that 2 350 kWh/kg U can be achieved.

It does not seem likely that anything much lower than this figure can be attained in the future.

Capital expenditure—From the angle of energy consumption, therefore, one must not look for any appreciable improvement in the profitability of the gaseous diffusion process; consequently the profitability can only be improved by cutting back the capital costs or through the fullest possible use of installed capacity.

Since the three American separation plants were built notable advances have been made in the compression system and various other components. At present the *USAEC* is carrying out a five-year development programme, the results of which will be available at the beginning of the seventies. With this process it was hoped in the United States to attain the following specific capital costs¹.

Separating capacity		
kg/y	$8.75 \cdot 10^6$	$17.5 \cdot 10^6$
Specific capital costs		
\$/kg/y	89	74.

These figures appear to have a relatively high representative value, in view of the fact that they are extrapolations performed on reliable bases.

Gas centrifugation

Principle—In the gas centrifuging process, gaseous uranium hexafluoride (UF_6) is contained in a rapidly spinning drum. As the centrifugal force is proportional to the mass of the molecules, the heavy fraction of the isotope mixture is subjected, in the radial direction, to a greater pressure increase than the light fraction. This results in partial separation of the two isotopic fractions, the lighter fraction being enriched in the vicinity of the rotor axis and the heavier around the internal surface of the rotor.

If a circulation flow similar to that shown in Fig. 2 is established in the UF_6 charge in the centrifuge rotor, the counterflow effect multiplies the sep-

¹ These values are given in 1970 dollars. A recent re-evaluation yielded figures of over \$ 100 (kg/y).

Figure 1: A cascade of gaseous diffusion stages.

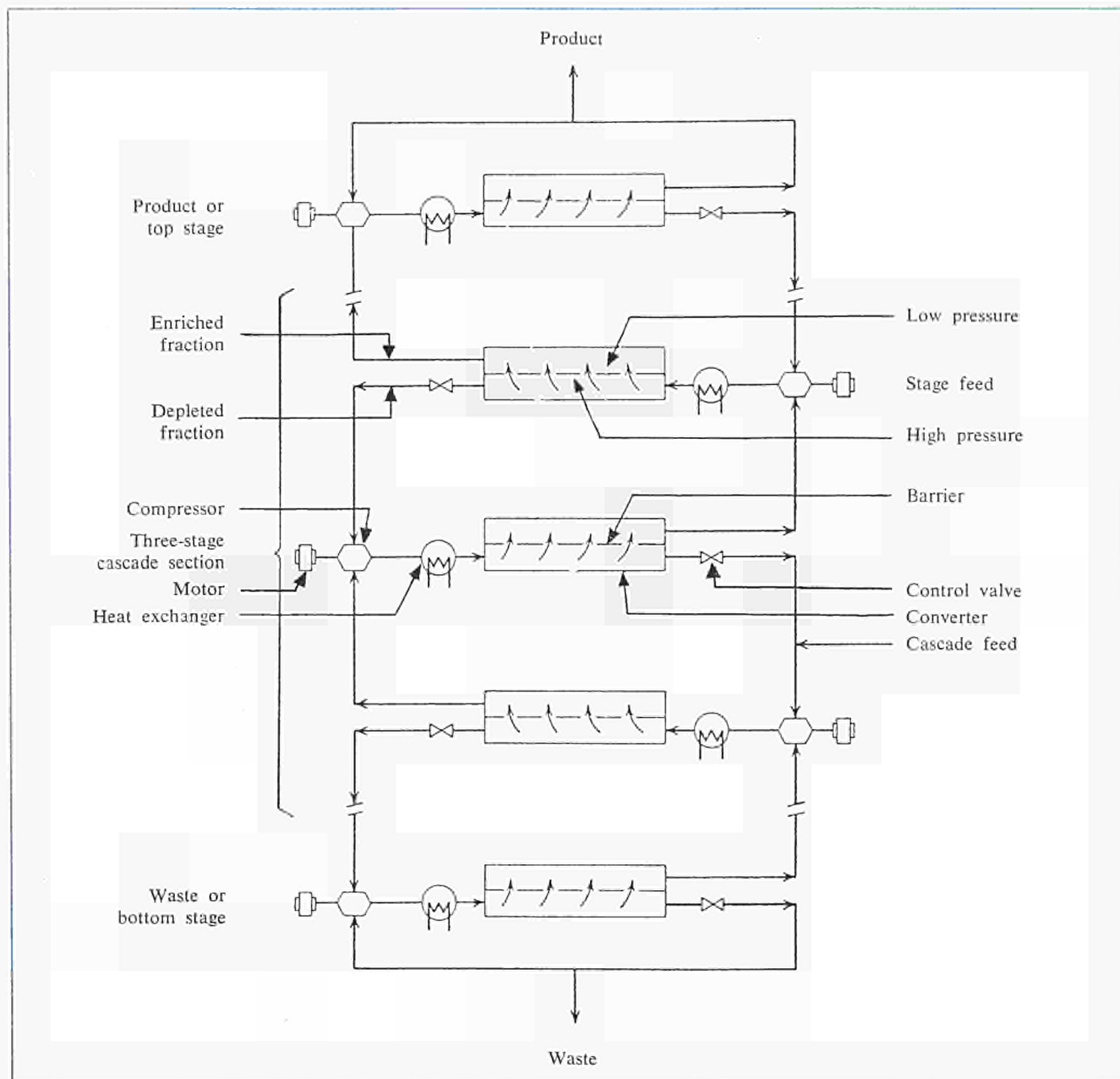

aration effect. Fig. 2 shows the basic principle of a centrifuge design, which might approximate to the characteristics of the gas centrifuges actually built.

The centrifuge rotor consists essentially of the centrifuging drum (2), the support pin (7), the rotor winding (5), the drive motor and a permanent magnet (9) at the top. The rotor winding of the electric motor is set in rotary motion by the stator winding and, at the top end, the rotor is held upright without contact by means of the fixed magnet (10). The support pin (7) spins in a groove of appropriate shape suitably lubricated from the socket bearing (8), with very little bearing friction.

To keep the gas friction outside the rotor at a low value, the UF_6 pressure in the gap (3) between the drum (2) and the tank (1) is maintained in the vacuum range. For this purpose the packing seals (4) are in the form of molecular pumps. The UF_6 to be separated (F) enters through a tube (11) which penetrates without contact into the centrifuging rotor. Inside the drum (2), the gas circulates downwards close to the axis, outwards at the bottom of the drum, upwards along the drum shell and then inwards at the top of the drum. This circulation can be induced by thermal effects or by the friction of the gas in the tube (11).

The depleted component (W)—the heavy fraction—is removed via the opening at the top of the drum (17), the tank (13) and the extraction pipe (12). The enriched (light) component (P) is drawn off through the lower drum opening (16), the tank (15) and the extraction pipe (14).

The essential problems in gas centrifuge design are several: one has to obtain the highest possible separating capacity, the lowest possible electricity consumption and the longest possible lifetime for the various components, and the whole must, of course, be designed as simply and cheaply as possible.

Separating capacity—The maximum theoretical capacity for a centrifuge of the above type, at ambient temperature and assuming a rotor length of 100 cm,

with a peripheral speed of 350 m/s, is about 3 kg/y.

The real separating capacity of a gas centrifuge is, for various reasons, lower than the maximum theoretical value. In the first place, the flow profile in the drum is different from the ideal theoretical case; secondly, there are effects due to mixing, turbulence and injection, axial backscattering occurs and there are losses at both ends of the drum.

In the 350 m/s range, which would still be feasible with aluminium alloy drums, effective separating capacities of nearly 80 % of the maximum theoretical values have been recorded. Hence it is possible to attain about 2.5 kg/y of separating capacity per metre length with drums of aluminium alloy.

In theory one might hope to increase the real capacity in a substantial degree by raising the peripheral speed, which means using better-quality materials for the drum. Unfortunately the separating efficiency decreases sharply when the peripheral speeds are raised, so that it is doubtful whether the enhanced separating capacity would offset the extra capital costs and electricity consumption.

Another way of raising the separating capacity would be to lengthen the rotor. However, the oscillatory behaviour of the centrifuge rotor imposes limits on its length; if it is to run at subcritical speeds, a certain ratio between the rotor length and diameter must not be exceeded (about 5 : 1). Whereas the theoretical separating capacity increases only linearly with the length of the centrifuge, the rotor mass would increase as the square of the length, at the least. In this case too, the rise in capital costs and electricity consumption imposes a limit on the possibility of increasing the centrifuge's separating capacity.

Electricity consumption—It is perhaps more important to reduce the electricity consumption than to increase the separating capacity per centrifuging unit. The scepticism of the French and American experts regarding the capacity of gas centrifuges as against the

diffusion process appears, in fact, to be based on the fact that the consumption rate of the aluminium centrifuges studied was far too high. In the case of gas centrifuges designed a few years ago, with a length of 1.25 m and a separating capacity of about 2.8 kg/y, the power consumption in some instances was of the order of 2.5 kW, the bearings being of rugged design. The resulting specific power consumption is thus 7 800 kWh/kg U, or more than three times that of the diffusion process. By using ball bearings it was possible to bring the power consumption down to about 0.8 kW, corresponding to 2 500 kWh/kg U, but structures of this type were not sufficiently durable.

According to the information available on the German, Dutch and British gas centrifuges, it appears that the specific energy consumption has been lowered to about 500 kWh/kg U. For a separating capacity of about 2.5 kg/y per unit, this value corresponds to a power consumption of only 0.14 kW for these centrifuges.

The attractiveness of these gas centrifuges really lies in the low power consumption.

Capital costs—The basic problem with gas centrifuges, however, seems to be the question of capital costs and the service life of the main components, both of which factors affect the economics of the process.

It is difficult to say what production cost should be regarded as realistic today in the case of gas centrifuges, since all the figures published to date ought to be regarded as target values. Obviously the present production cost must be appreciably higher than the target cost, mainly on account of the short fabrication runs and the progress still to be made in the development field.

Subject to all the usual reservations, one can estimate that in the event of series manufacture, centrifuges of the type that can be built today will probably, in about five years, cost about \$ 250 a unit, or roughly \$ 100/(kg/y). To this cost must be added that of the auxiliary installations and the cascade

Figure 2: Gas centrifuge:

F) ingoing mixture; W) depleted component; P) enriched component; 1) tank; 2) centrifuging drum; 3) vacuum space; 4) molecular pump seal; 5) rotor winding of electric motor; 6) stator winding of electric motor; 7) support pin with arms; 8) bearing socket with lubricant supply; 9) permanent magnet on centrifuging drum; 10) fixed magnet; 11) fixed gas feed tube; 12) inlet tube for depleted fraction; 13) depleted gas chamber; 14) outlet tube for enriched fraction; 15) enriched gas chamber; 16) drum bottom opening; 17) drum top opening.

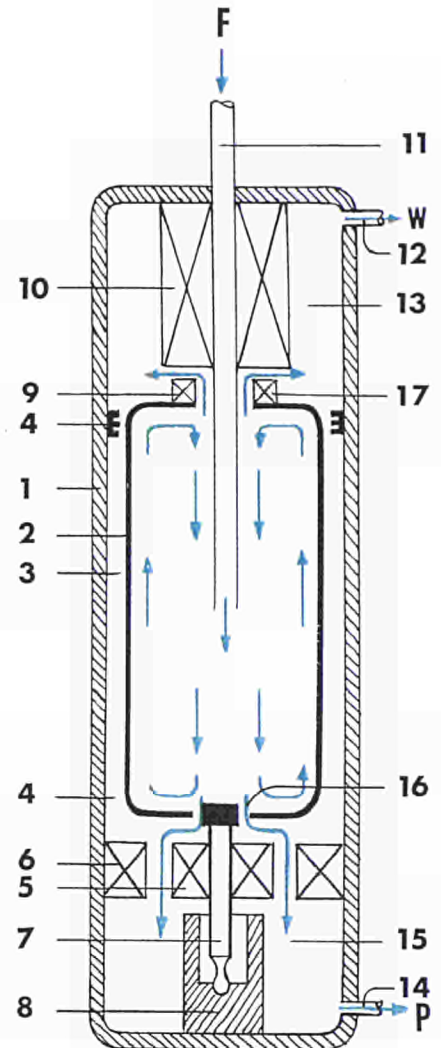

equipment, which will certainly not come to less than half the actual centrifuge cost. The centrifuges now on order certainly cost several times this price. In this connection it should be mentioned that the estimated price of certain centrifuge prototypes has been valued at about \$ 10 000 a unit (including the auxiliary plants).

The length of service of the main components (drum, bearing and drive device) will depend on how closely conventional design is adhered to and how frequently the centrifuge is serviced. The view which envisages a service life of about five years for the main components seems to be reasonable for the moment.

Present state of development and future prospects—The centrifuges planned for the enrichment plants at Capenhurst (50 t/y separating capacity between now and 1972) and Almelo (2×25 t/y by the end of 1971) might still be equipped with a drum of light metal or special steel (length approx. 1 m, diameter approx. 0.2 m, speed about 33 000 rpm). It may be possible, however, as already stated, to use drums of fibre-reinforced synthetic material, which could be considerably smaller (with speeds of over 100 000 rpm). In any event such components could only be used if, first, the problem of corrosion by UF_6 can be solved and, secondly, fibre-reinforced synthetic materials can be produced at a far lower cost. Hitherto the cost of this material has been around \$ 900/kg. In

the event of mass production, this figure could probably be brought down to about one-fifth.

The technical development potential of gas centrifuges with light metal or steel drums appears to be more or less exhausted. Only in the production cost is there still perhaps room for economy through series production. From the standpoint of the production cost, the centrifuges with a drum of fibre-reinforced synthetic material show good promise of reducing the cost of separation work. It is still too early to decide whether the optimistic predictions made in some circles in this respect are justified.

The nozzle separation process

Principle—The layout of the separation nozzle being used by Professor Becker at Karlsruhe is shown in Fig. 3. It comprises a guide section (1), a deflector (2) and a stripper (3). The gas feedstock is a mixture of 5 mol. % UF_6 and 95 mol. % He, admitted on the left-hand side of the device. An underpressure, lower by a factor of about one-quarter, is maintained in the chambers to the right of the guide section.

Owing to the pressure gradient, the mixture flows into the curved *Laval* nozzle formed by the guide section and the deflector and, because of the centrifugal force, whose value is a function of the mass, the heavy isotopes tend to concentrate on the inner face of the deflector. The stripper splits the flow into a heavy (4) and a light (5) fraction, and these are drawn off separately.

Separating capacity—As yet no serviceable data are available for a theoretical calculation of the separating capacity of the nozzle process. An estimate can be made, however, based on the compressive work and the separating capacity of a stage: if the separation factor 1.012 is adopted in respect of a UF_6 proportion of 5 mol. %, then one obtains a value of about 5 800 kWh/kg for the specific energy consumption.

In theory it could be deduced that the specific energy consumption of the nozzle process is in more or less inverse proportion to the average UF_6 concentration. It would thus be quite easy to cut down the specific energy consumption of this process, simply by reducing the proportion of helium in the gaseous mixture.

If this is done, however, it reduces the rate of flow in the separation nozzle. Roughly speaking, the separating capacity is proportional to the fourth power of the flowrate. If, for instance, the UF_6 content is raised from 5 to 10 mol. %, the flowrate drops to such an extent that the available separating capacity is reduced to a quarter of its original capacity. In the technical-scale separation stage built at Karlsruhe the separating capac-

ity is expected to be about 0.85 kg per year and per metre length. By raising the UF_6 proportion to 10 mol. %, one would bring the separating capacity per running metre down to about 0.21 kg/y, and the specific capital costs would thus increase to an unacceptable degree. The higher UF_6 concentration would have another disadvantage: the inner diameter of the nozzles would have to be made even smaller (in the Karlsruhe technical-scale separation stage the diameter is to be 0.03 mm).

Hence, as long as the specific capital costs are not distinctly lower than those of the other separation processes, the profitability of the nozzle separation process will not be enhanced by lowering the proportion of helium in the gaseous mixture. From this point of view, the figures quoted so far by Becker (\$ 120 per kg/y for a plant with a separating capacity of 700 000 kg/y) are not very encouraging as yet.

Another possible way of improving the separating capacity is by using hydrogen instead of helium as the carrier gas. Becker believes that this would afford a saving of about 30 % on the energy cost and capital costs.

Present state of development and future prospects—The characteristics of the separation stage brought into ser-

vice at Karlsruhe in the spring of 1970 are shown in Table I.

In addition to the tubes, the vessel contains the cooling elements and a radial compressor with two cooling stages, intermediate and final, with a suction capacity of 100 000 m³/h.

To assess the capacity of this separating stage we must wait for the operating results. It will undoubtedly be even more important to learn the production cost at a separating plant applying this technique on the industrial scale. In this connection we should mention the studies that *Steinkohlen-Elektrizität AG*/Essen and Karlsruhe have been conducting jointly since early 1970.

As to the future prospects of the nozzle process, the essential question is whether it will be possible either to increase the separating capacity per running metre of slit length (there still appears to be some margin here), or else to pare down the specific capital costs per running metre of slit length. If the answer is affirmative in both cases, it would be possible to bring the specific energy consumption down to economically viable levels. For technical and safety reasons, the prospects of using hydrogen as the carrier gas must be regarded as hypothetical at the moment.

Table I: Characteristics of the nozzle separation stage at Karlsruhe (1970).

Diameter of deflector	0.2 mm
Diameter of nozzle at narrowest point	0.03 mm
Admission pressure of He- UF_6 mixture	600 torr
Internal expansion ratio	4
UF_6 separation ratio	1 : 3
Elementary separation effect	$1.18 \cdot 10^{-2}$
UF_6 throughput per metre of slit length	$8.35 \cdot 10^4$ kg/y
Separating capacity per metre of slit length	0.85 kg/y
Separation slits per nozzle	10
Tube diameter	approx. 0.1 m
Tube length	approx. 2 m
Number of tubes per vessel	100
Separating capacity of vessel under full load	1 700 kg/y
Vessel diameter	approx. 2 m
Vessel length	approx. 6 m
Expected specific energy consumption	5 500 kWh/kg

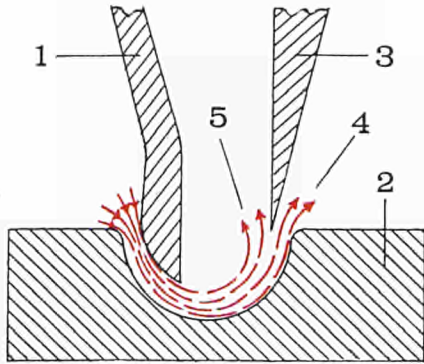

Figure 3: Separating nozzle:

- 1) guide section; 2) deflector; 3) stripper;
- 4) heavy fraction; 5) light fraction.

Conclusions

Of the three foregoing processes for separating uranium isotopes, only the gaseous diffusion process has attained industrial maturity and can thus be assessed with fair precision from the economic and technical standpoint. The limitations of this process lie mainly in its relatively high specific energy consumption, which can no longer be influenced to any notable extent.

As for the gas centrifuge process, it is already certain that its specific energy consumption is one-fifth or one-sixth of that of the gaseous diffusion process. Regarding the specific capital costs, a distinction must be made between a design using a drum of light metal or special steel, and a construction method that employs an extremely hard material for the drum. In the first case, the development potential will basically consist in cutting back manufacturing costs by means of series production, whereas in the second case one can expect a substantial increase in the separation capacity per unit, stemming from more advanced development work and resulting in a corresponding direct drop in the specific capital charges and a further indirect improvement due to simplification of the plant as a whole. Obviously, for this second type of centrifuge, the economic impact of mass production is

also of major importance. Lastly, it is still not known if the specific capital costs of the centrifuge process can be brought close to the well-established figure for the diffusion process. If so, the economic superiority of the gas centrifuge will be indisputable.

At present the nozzle process is less profitable than gaseous diffusion as regards both the specific energy consumption and the capital costs. Nevertheless it appears that the present energy consumption could be further reduced, although the reduction would probably be at the expense of the separative power per running metre of nozzle breadth. The nozzle separation process will thus not become competitive unless the capital costs, in terms of the nozzle breadth, can be cut down from \$ 102/m (today regarded as feasible) to a relatively small fraction of that figure. Owing to the precision requirements for the present type of nozzle, it appears that this will be very difficult to achieve. Even so, it is still possible that more efficient designs may be discovered which will meet these conditions more closely.

EUSPA 10-8



The "brown fumes"

An atmospheric pollution problem: the control of "brown fumes" in oxygen-blown steelworks.

PIERRE LEMOINE and GERHARD WILL

The growth of oxygen-blown steel production

During the past ten years steel production has been radically transformed by the introduction of a process whereby pig iron is refined with technically pure oxygen. The products obtained in this way are of better quality and are gradually replacing open-hearth and basic Bessemer steels. We are consequently witnessing a rapid development of this process at the expense of the conventional techniques.

In 1958, oxygen-blown converters accounted for 600 000 tonnes of the European Community's total crude steel production, equivalent to about 1 %. By 1967, however, the share had increased to 28 %, representing an output of 25 million tonnes. In 1970, approximately 45 % of the total production (i.e. about 110 million tonnes) was made by this process and it is estimated that in 1972 this share will exceed 68 %.

At the same time the part played by open-hearth steelworks is slowly but steadily declining, while the relative importance of the basic Bessemer plants is diminishing very rapidly.

PIERRE LEMOINE, *Ing. civil des mines*, and GERHARD WILL, *Dr.-Ing. der Hüttenkunde*, belong to the Directorate-General for Social Affairs of the Commission of the European Communities, where they are employed in the special department for "Safety Matters in the Coal and Steel Industries".

Oxygen-blown converters

Since the purpose of this article is not to discuss the problems of steel-making as such, but to examine those

Figure 1: Schematic diagram of an LD converter.

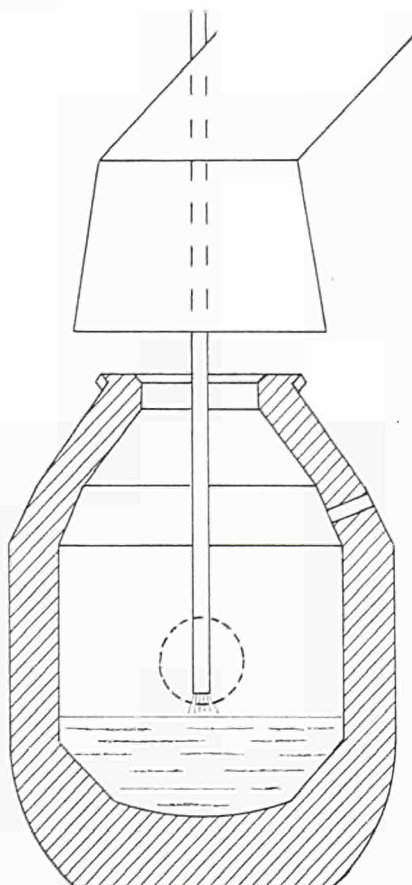

relating to methods of controlling atmospheric pollution, all that can be done here is briefly to review the technique of refining pig iron by means of oxygen.

The new oxygen-blown converters are axisymmetrical crucibles lined with refractory materials, in which the molten pig iron, to which are added steel scrap or iron ore as well as fluxes, is refined with oxygen blown on to the bath from above.

A distinction is made between the true LD¹ process, used for refining pig iron with phosphorus contents of up to 0.5 %, and the LDAC², OLP³, Kaldo⁴ and similar processes, which allow the refining of pig iron containing more than 0.5 % of phosphorus. The Kaldo process is characterised by the rotation of the crucible about its longitudinal axis.

Each type of converter pivots about a horizontal axis for charging and tapping (Figs. 1 and 2).

In both cases oxygen is blown slightly above the surface of the molten pig-iron bath by a water-cooled lance. The high exit velocity of the oxygen causes violent eddies in the bath and promotes

¹ Linz and Donawitz: towns in Austria where the *Vereinigte Österreichische Eisen- und Stahlwerke (VOEST)* and the *Alpine Montangesellschaft* have their respective head offices and where the pure-oxygen steel-making process was developed between 1949 and 1952 and has been applied on an industrial scale since 1953.

² Linz, Donawitz, *ARBED* and *Centre National de Recherches Métallurgiques Belgo-Luxembourgeois*: a form of LD process in which powdered lime mixed with oxygen is blown on to the bath. This process has been in use at Dudelange, Luxembourg, since 1958.

³ Oxygen, Lance, Powdered Lime: a process which was introduced at the end of 1957 by the *Institut de Recherches de la Sidérurgie Française (IRSID)* and which differs from the LDAC process only in the way in which the powdered lime is brought into suspension in the oxygen jet and the method of regulating its flow.

⁴ A process devised and developed by the Swedish professor Bo Kalling at the *Domnarvet* works of the *Stora Kopparberg-Bergslags AB* between 1948 and 1955 and applied on an industrial scale since 1956. Like the LDAC and OLP processes, it enables phosphorus-rich pig irons to be treated through the use of a second slag.

contact between the oxygen and the melt, resulting in rapid oxidation of the impurities present in the latter (silicon, manganese, phosphorus and carbon).

The introduction of triple-jet lances resulted in fewer ejections of the melt towards the converter mouth—an effect which, as explained below, is not without interest as regards the development of processes for collecting the gases.

The treatment of a charge is of relatively short duration and the refining operation can be represented diagrammatically as in Fig. 3, in which three phases, lasting 22 minutes in all, are distinguished. In the first phase the silicon and manganese are oxidised before the carbon. In the second phase the oxygen reacts predominantly with the carbon. In the last phase the primary aim is to produce a metal of the quality desired.

The quantity of oxygen required in the course of a cycle is very large: in the case of a 250 tonnes converter the flow rate can be as high as 1 000 Nm³ per minute. The result is that after a short time there is a violent discharge of fumes at a temperature of between 1 400 and 2 000° C. These fumes, which leave the converter, are a mixture of gases (90 % CO) and special kinds of dust which will now be discussed more fully; the whole is commonly known as “brown fumes”.

The size of oxygen-blown converters has increased rapidly over the years; between 1952 and 1969 the capacities rose from 30 to 300 tonnes and even more. The quantities of brown fumes produced have naturally increased at the same rate and the dust removal plants have had to be constantly adapted to keep pace with the production.

Brown fumes

From the physical point of view these fumes are residual gases containing suspended microscopic particles of iron oxide (Fig. 4) the size of which is of the same order of magnitude as

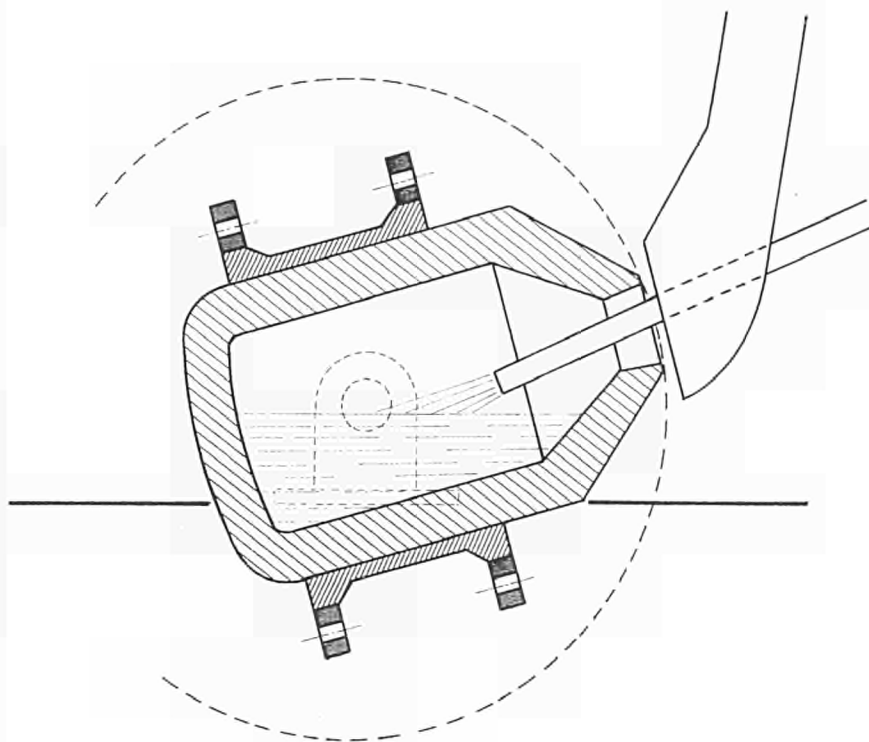

Figure 2: Schematic diagram of a Kaldo furnace.

that of tobacco smoke particles. The fineness of these particles is due to the way in which they are formed: the reaction between the oxygen and the melt causes local evaporation; the iron vapours combine with the oxygen, with the result that they condense into very fine particles of iron oxide which, when entrained by the residual gases, impart to the latter the reddish-brown colour that is so characteristic of them even when they are diluted in the atmosphere. The “dust” thus defined contains over 80 % of iron oxides. It is composed as to 95 % of particles with a diameter of 100-800 nm; these represent 1-2 % by weight of the steel blown.

Let us now examine the behaviour of the gas that carries them:

During the refining of pig iron, 1 kg of carbon burns 0.93 Nm³ of oxygen and forms 1.86 Nm³ of carbon monoxide. At a combustion rate of 0.4 % C per minute, therefore, the release of CO from a 150 tonnes top-blown oxygen converter is 67 000 Nm³ per hour. To this quantity of gas, which,

at a temperature of about 1 600° C, actually occupies a volume six times as great, the infiltrating air adds an amount of gas which varies according to the prevailing conditions; this gas mixes with the converter gas proper and causes its combustion, thereby considerably increasing the quantity of waste gas to be treated.

For example, a medium-sized converter of 150 tonnes, operating at a decarbonisation rate of 0.4 % per minute and complete combustion of the gases with a 50 % excess of air, requires a dust removal plant with a capacity equivalent to 275 000 Nm³/h of waste gas.

For cleaning purposes, the gases must first be cooled to temperatures varying from 50 to 300° C, according to the cleaning method selected.

In the case of the 275 000 Nm³ assumed in the foregoing example, this

means that the heat output is some 220-240 million kcal/h.

Furthermore, since these waste gases have to be wetted before being treated in the dust removal plants⁵, the result is that, owing to the absorption of water vapour, the actual quantity of gas to be drawn off by the fans is between two and three times that produced by the converters (i.e. from about 550 000 to over 800 000 m³/h instead of the above-mentioned 275 000 Nm³).

Collecting the brown fumes

There are numerous ways of classifying the dust separating plants for converters. However, as far as the actual collecting of the brown fumes is concerned, there are two basic categories, which operate on different principles. The brown fumes can be collected either after combustion of the gas (mainly CO) in the ambient air, or without combustion of this gas, in the latter case by preventing the ingress of air between the converter mouth and the collecting hood.

Collection after combustion

As was mentioned earlier, varying volumes of combustion gases are obtained at the converter mouth, depending on the air excess admitted (this is denoted by the coefficient n).

These gases are at a high temperature and it is desirable to cool them before passing them to the dust removers. The radiant heat can be absorbed by low- or high-pressure boiler tubes installed in the hood. The disadvantage of the system, if the object is to utilise the large quantities of steam generated, is the intermittent functioning of these boilers, dependent as they are upon the operation of the steelworks.

⁵ As a rule the gases at a temperature of 1 600°C or higher have to be cooled down to:

150-200°C if dry electrostatic filters are used;

30- 70°C if wet electrostatic filters or water scrubbers are used;

100-150°C if filter candles are used.

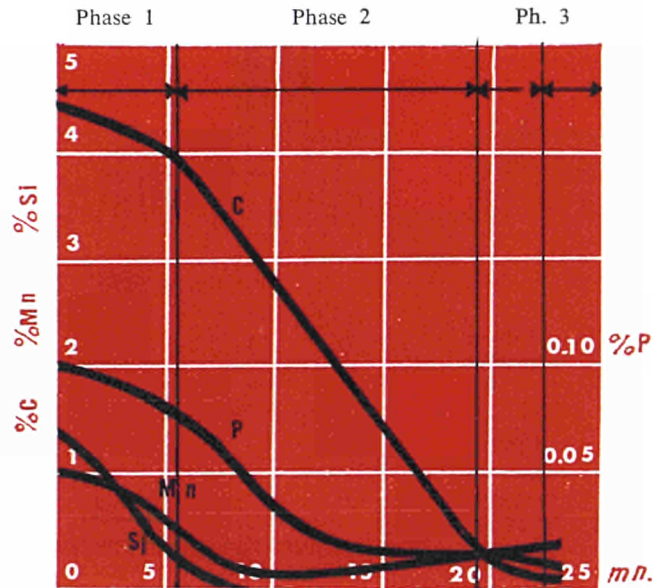

Figure 3: Graph showing the combustion of the elements C, P, Mn and Si during the refining of pig iron.

Figure 4: Particles of brown fumes (photographs taken through an electron microscope).

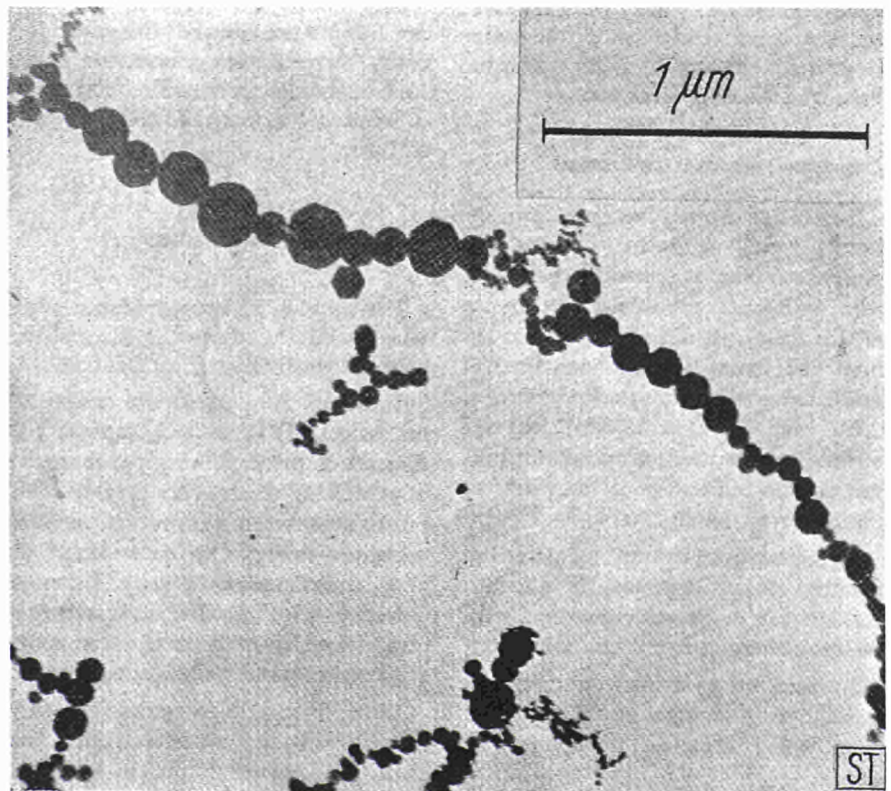
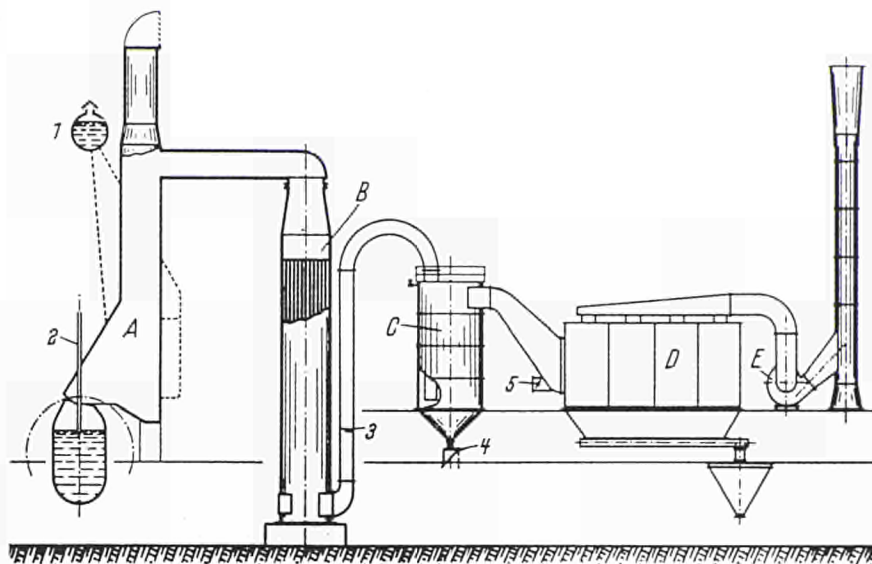

Figure 5: Schematic diagram of an installation for the cleaning of LD converter gases by means of bag filters.

A) Double-walled suction hood with natural circulation; B) heat exchanger; C) cooling tower (water spray); D) bag filter; E) fan; 1) expansion tank; 2) oxygen lance; 3) flap valve; 4) slurry discharge; 5) infiltration air inlet.



In order to overcome this drawback, some plants are equipped with supplementary burners which operate when the converters are shut down and thus ensure continuous steam production.

In the other plants the hood is water-cooled, either with or without evaporation of the water. In such cases the supply and treatment of the water is attended by considerable problems, both technical and economic.

Collection without combustion

Instead of allowing the gases to burn normally with an excess of air at the converter outlet, it is possible to collect them, without combustion, for re-use in the plant. It should be borne in mind that these gases are rich in CO and have a calorific value of between 2 000 and 2 500 kcal/Nm³. Several techniques have been proposed for preventing the combustion of the gases at the converter outlet.

By means of a pressure regulator the quantity of gas aspirated by the fan can be made to coincide any time with the quantity produced by the converter.

By resorting to a slight dilution it is possible to draw off a curtain of burnt gases which protects the main gas stream.

A device used in Japan provides a seal by injecting nitrogen into a sleeve mounted on the converter neck.

Since in plants where the waste gases are collected without combustion the volume of gas to be treated is appreciably less, the installations for collecting, cooling and scrubbing the gases are likewise smaller and therefore less costly. Nevertheless, precautions have to be taken to prevent the formation of explosive mixtures of CO-rich gases and air.

Dust removal installations

It is beyond the scope of an article such as this to review all the existing types of dust removal installations.

It should be pointed out, however, that since 1958 the ECSC has promoted research in this field in implementation of Article 55 of the Paris Treaty. This research has been incorporated in programmes aiming at the reduction of air in the metallurgical industry. Its main objective is to improve dust removal installations, to make them safer, more efficient, cheaper and easier to operate.

In the light of the foregoing explanations it will be understood that the effort has related primarily to dust

removal installations which operate without combustion, since it is known from the outset they take up less space and that the gases can be recovered.

The installations described below are those on which research with financial aid from the ECSC has been or is still being conducted.

a) Collection preceded by combustion —Cleaning by means of bag filters

Cloth filters have a very high dust-collecting efficiency but very soon become clogged when the temperature drops below 100° C, since the dust particles are then moistened by absorption of water vapour. At temperatures above 150° C, however, cotton and synthetic fabrics deteriorate. These factors have consequently deterred the development of such cloth filters for the cleaning of brown fumes.

As a result of the research promoted by the ECSC these drawbacks were overcome by providing a Cowper-type heat exchanger downstream of the converter stack. In this exchanger the converter gases are precooled in a double-walled suction hood with water circulation, thereby giving up most of their residual heat. If necessary, their temperature is further reduced to the required level of 85-100° C by a water spray in a cooling tower located down-

Figure 6: Bag filter installation assembled on an LD converter.

stream of the heat exchanger. The gases then enter the bag-filter installation, at the outlet of which residual dust contents of as little as 6 mg/Nm^3 have been measured.

A series of measuring, control and safety devices ensures faultless operation of the equipment (Figs. 5 and 6).

The suction hood consists of an ordinary boiler with natural water circulation; the steam generated is vented to atmosphere, since its utilisation was not considered worth while in the given circumstances.

The bag-filter unit is composed of 22 cells, each containing 24 filter bags, i.e. a total of 528 bags. The cells are shut down in a controlled sequence every seven minutes and the filters cleaned by transverse shaking and simultaneous blowing in a counter-current air stream.

The dust is collected in hoppers located at the bottom of the cells, car-

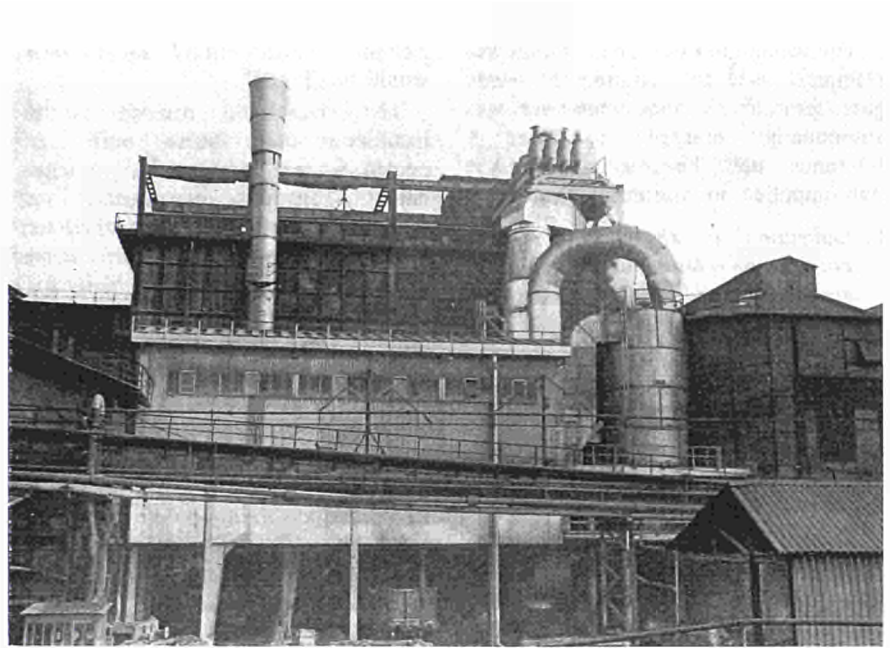

ried by screw conveyors to an automatic bagging plant and returned to the converter in 50 kg paper bags.

After 18 months' service, representing approximately 3 500 operating hours, the Tergal filter bags showed no sign of wear.



The installation described, which was originally used for cleaning the waste gases from an 18 tonnes converter, was subsequently enlarged to serve a 60 tonnes unit. The dust deposited is now supplied to a sintering plant.

b) *Collection of the gases without combustion—Dust removal by wet scrubbing and dry electrostatic filters*

The first study on dust removal installations of this type was carried out at a steelworks equipped with 130 tonnes LD converters. The dust is removed by wet scrubbing after collection of the gases.

The study was concerned with determining the most suitable design for the hood, with a view to reducing air infiltration at the converter mouth.

Experience prompted the choice of a non-sealed system, with pressure control via regulation of the draught. This arrangement has the advantage of allowing direct observation of the converter flame, this being useful for technical reasons. Moreover, the hood is less vulnerable to damage by converter

ejections than an entirely closed sleeve would be (Fig. 7).

The original plan provided for the installation of a tubular boiler connected to the hoods and of a superheater to produce dry steam. From there the gases flowed to a horizontal saturator, in which they were cooled by water vaporisation, and then to a vertical scrubber equipped with a large number of Venturi nozzles. A series-connected fan then sent the scrubbed gases to a flare stack at the top of which they were ignited.

As a result of the tests a number of substantial technical modifications had to be made to the original scheme. The superheater, fouling of which impeded the gas flow, was dropped. The size and arrangement of the hood were changed; at the same time, in order to prevent dust accretions, the boilers were replaced by slag catchers in the form of double-walled hoppers water-cooled by vaporisation at atmospheric pressure and equipped with a refractory bottom (Fig. 8).

The only drawback resulting from these modifications was that of no

longer having available, at the very place where it was needed, the source of the steam necessary for providing a leaktight seal around the lance and inside the charging chute; the steelworks steam circuit consequently had to be connected to the mill's steam system.

Finally, triple-jet oxygen lances were installed in order to reduce the ejections of liquid pig iron and steel and thus prevent the formation of skulls which adhere to the hoods.

An essential requirement from the plant safety standpoint was to prevent the formation of any explosive mixtures under practical operating conditions. It was also necessary to avoid highly toxic emissions of carbon monoxide in all spaces where personnel might have to work.

The first of these safety problems was solved by arranging for the waste-gas circuit to be scavenged by a plug of burnt gas ($\text{CO}_2 + \text{N}_2$) before and after each blowing period. In addition, explosion doors are provided throughout the circuit.

As regards carbon monoxide emissions, all places where CO was likely to accumulate were provided with direct discharge lines running over the roof.

Also installed was a nozzle at the top of the flare stack to increase the gas velocity and prevent flare-backs.

The desired efficiency of dust removal was not obtained with this installation until the overall gas aspiration capacity had been stepped up and the power of the fans increased to 290 kW to give a flow rate of 100 000 m³/h. In this way the average residual dust content in the gases discharged was reduced to 100 mg/Nm³, which is an acceptable value both from the point of view of atmospheric pollution and as regards the recovery and possible future use of the gases.

A second type of dust removal plant operating without combustion of the CO, but this time using a dry process, is currently under study at another steelworks in the Community. This makes use of electrostatic filters installed downstream of two 200 tonnes LD and LDAC converters (Fig. 9).

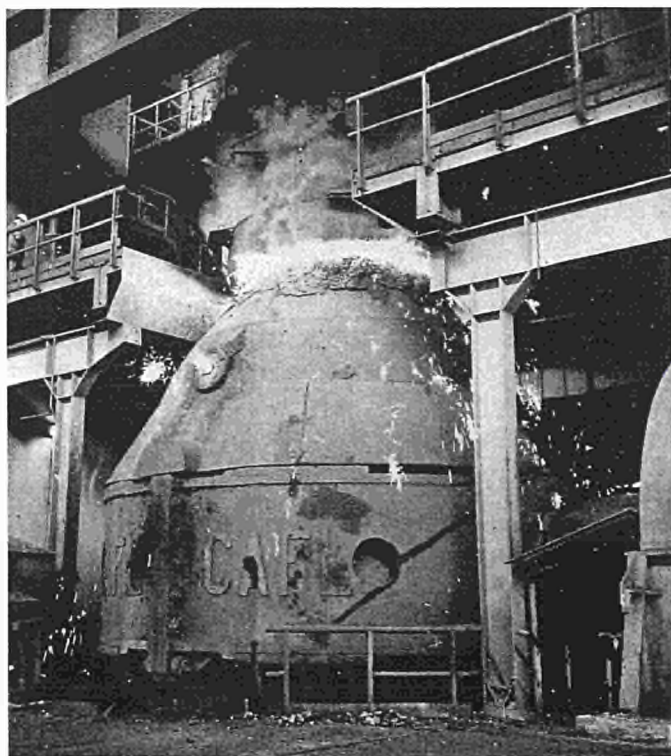

Figure 7: Converter with gas-collecting hood.

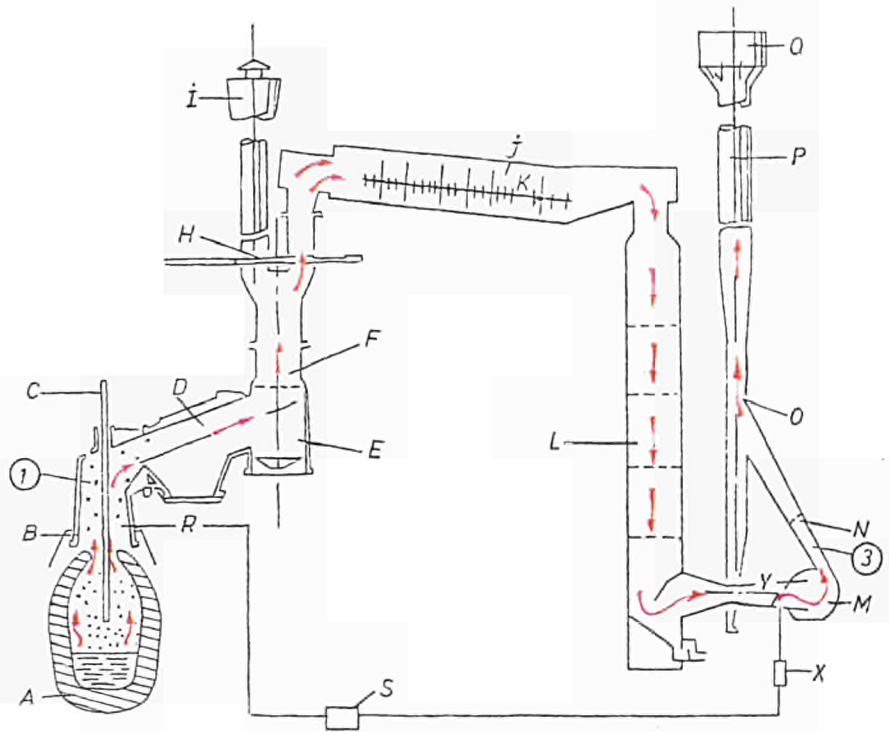

Figure 8: Schematic diagram of an installation for the cleaning of LD converter gases by wet scrubbing.

A) Converter; B) suction hood and collecting skirt; C) oxygen lance; D) slag chamber; E) conditioning tower; F) spray bars (30 m³/h of water at 100° C); H) flap valve closed; I) stack (direct draught); J) saturator; K) constant-rate spray bar; L) scrubber; M) 400 hp extractor fan; N) diaphragm; O) deflector; P) stack; Q) flare; R) pressure sensor; S) control relay; X) servomotor; Y) butterfly valve; 1) dust-laden gas at 1 630° C; 2) scrubbed gas at 50° C, 100 % humidity, 190 000 m³/h; density: 1 085 kg/m³.

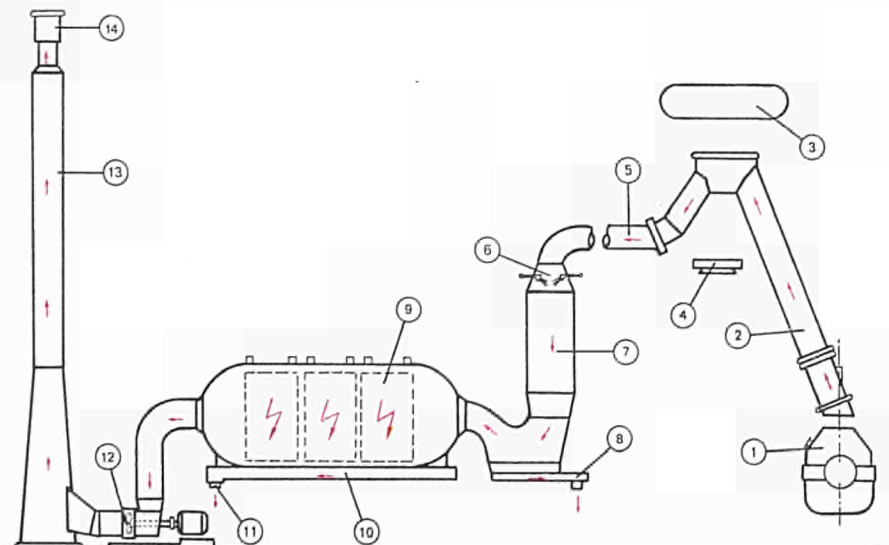

Figure 9: Schematic diagram of an installation for the cleaning of LD/LDAC converter gases by dry precipitation.

1) Converter; 2) oiler with natural circulation; 3) boiler drum; 4) condenser; 5) raw-gas duct; 6) spraying; 7) conditioning tower; 8) horizontal conveyor; 9) three-field dry electrostatic filter; 10) horizontal conveyor; 11) dust discharge; 12) fan; 13) clean-gas stack; 14) electrical ignition of the gases.

The collecting hood is designed as a boiler with natural circulation (heating surface 410 m², heat output 77 million kcal/h).

The combustion rate ($n = 0.2 - 0.3$) was so chosen that the emitted gas volume (111 600 Nm³/h) does not exceed a temperature of 1 000° C at the mouth of the hood.

The boiler tubes in the hood are arranged in such a way that the ejection from the converter do not readily adhere to them.

Downstream of the hood is a raw-gas duct which, owing to the high temperature of the gases, is lined with refractory materials.

The gases then pass to a cooling tower. This tower plays a very important part, since it is required to lower the gas temperature from about 925° C to 200° C, this being the inlet temperature of the electrostatic filters. The water throughput can be varied according to the gas flow rate and temperature and is fixed at between 185 and 362 g H₂O/Nm³. In absolute figures, the volume of water can fluctuate from 10.8 to 56 m³/h.

The electrostatic filters are designed for a flow rate of 318 600 m³/h; they can admit a gas containing 100 g of dust per Nm³ and discharge it with a content of 100 mg/Nm³, thus giving a filtration efficiency of 99.9 %. The gas circulation is effected by a fan with a capacity of 260 000-360 000 Nm³.

The waste-gas flow through the electrostatic filters is maintained constant throughout the converter blowing period, being regulated as a function of the converter operating conditions and the intake of make-up air.

The electrostatic filters and the gas ducts are constructed in such a way as to ensure a uniform gas flow, thus avoiding dead spaces where local accumulations of explosive mixtures might occur. As a precaution, calibrated safety valves are installed throughout the circuit travelled by the gases.

The electrostatic filter comprises three series of electrodes which are separately fed with direct current from a fully thyristorised rectifier unit. This ensures the availability at all times of

the requisite voltage as a function of the gas flows and dust concentrations.

The dust retained in the filter is removed in a continuous process, stored in a silo and then loaded on to trucks.

The cleaned gases are drawn off by the fan and discharged to a stack at the top of which is a flare equipped with a special ignition system and a pilot burner.

Conclusions

It has not been possible in this article to mention all the problems relating to the collection and precipitation of converter fumes. A great deal remains to be done in this field before the installations can be made less bulky, still more effective, safe and economically acceptable from the investment and operating standpoint. Dust control in oxygen-blown steelworks is, after all, a difficult task which calls for substantial technical efforts.

The solving of these problems is a major concern of the Commission of the European Communities. It will contribute in no small way to environmental protection and industrial safety as well as to the improvement of living and working conditions.

EUSPA 10-9

Literature: (1) *AECD*: La pollution atmosphérique dans la sidérurgie (1963). (2) *US Department of Health, Education and Welfare*: Air pollution aspects of the iron and steel industry (1963). (3) A.D. ROWE, B.A. BASSET: Waste gas cleaning systems for large-capacity basic oxygen furnaces, *Iron and Steel Engineer*, January 1970. (4) M. HUYSMAN, A. MAUBON: Amélioration de la technique de dépoussiérage des gaz résiduels de convertisseurs à l'oxygène par captage sans combustion, *Revue de Métallurgie*, May 1968. (5) A. MAUBON: Système de captage sans combustion *IRSID-CAFL* - Résultats obtenus à Dunkerque. Modifications apportées au circuit. *CIT* (1969) No. 11. (6) JOHN W. BROWN: Gas handling systems for top-blown oxygen converters, *Steel Times*, September 1970. (7) KNUT BEHRENS: Stahlerzeugung nach dem Sauerstoffaufblas-Verfahren in großen Konvertern, *Stahl und Eisen* 85 (1965) No. 4. (8) ERNST WIEGAND, WERNER RESCH, DIETER NOLLE, HAUSGERD BANSEN: Das neue Sauerstoffaufblas-Stahlwerk im Werk Salzgitter der Stahlwerke Peine-Salzgitter AG, *Stahl und Eisen* 90 (1970) No. 26.

Remote Sensing

A field that Europe has neglected: the observation of the earth's resources from aircraft and spacecraft.

CHRISTIAN GARRIC

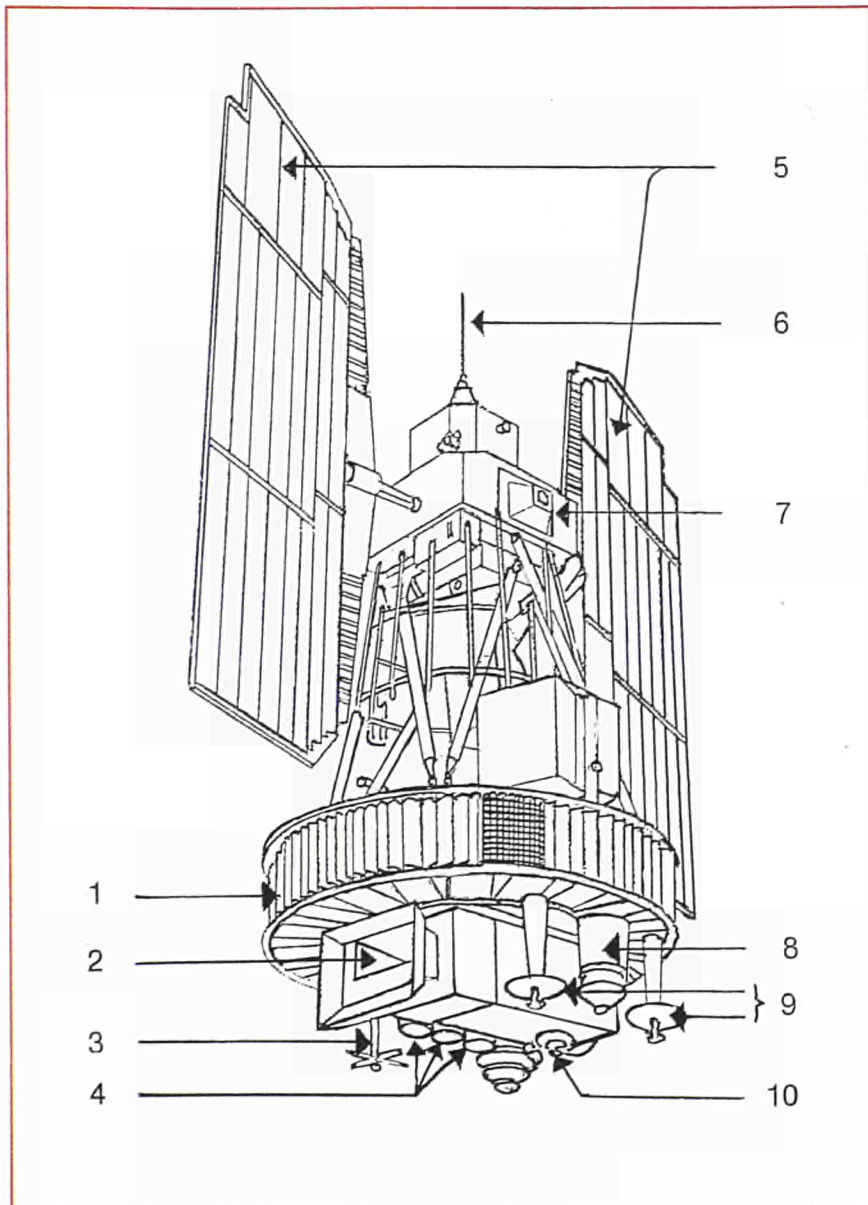
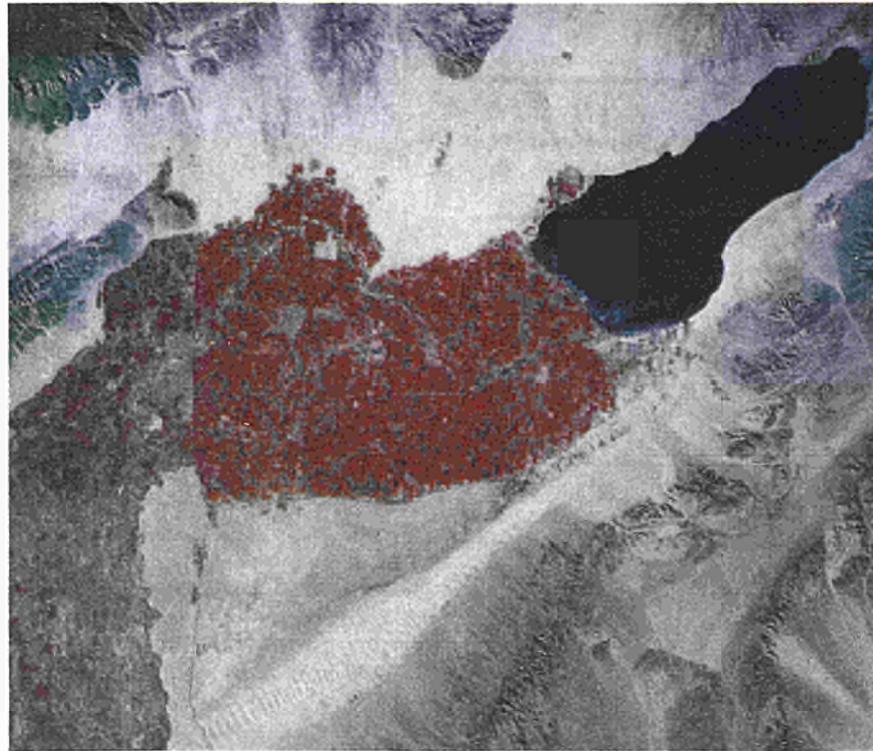

Fig. 1: The essential features of the ERTS-A satellite, to be launched by NASA early in 1972. It is a technological test satellite for observation of earth resources. The remote scanners it carries are a set of three TV cameras, each working in a given region of the light spectrum, and a multispectral scanner. They will be able to provide 25 000 images a week. The data are transmitted to the ground by radio when the satellite is within view of the receiving stations (sited at Fairbanks, Alaska; Corpus Christi, Texas; Greenbelt, Maryland). The satellite also carries a magnetic tape recorder which enables it to retransmit, as it passes over the stations, images taken while it is out of contact with them. It also has a system enabling it to interrogate up to 1 000 measuring platforms dispersed over the globe and to transmit the data received from them to the central stations.

- 1) Main data-transmitting antenna;
- 2) Passive cooling system for scanner detectors;
- 3) Antenna for communications with ground platforms;
- 4) Three-band television camera;
- 5) Sun-directed solar arrays;
- 6) Command antenna;
- 7) Horizon scanner for altitude control;
- 8) 2 GHz antenna;
- 9) Telemetry and tracking antennae;
- 10) Multi-spectral scanner window.

*

CHRISTIAN GARRIC is responsible for space questions at the Directorate-General for Industrial, Technological and Scientific Affairs, Commission of the European Communities.



Figs. 2 and 3: Vegetation studies. Views taken on "false-colour" emulsion, sensitive to green, red and infra-red. Healthy vegetation has a reflectance peak in green and a stronger peak in the near infra-red range. The latter peak is proportionately weaker with unhealthy vegetation. "False-colour" photographs show healthy vegetation as bright red, whereas plants affected by disease or parasites appear as green or white. In some cases the effect is perceptible in false colour before it becomes visible to the observer on the ground. In all cases the contrast is better in false colour.

Fig. 2 is a false-colour view, taken by Apollo 9, of Salton Sea and Imperial Valley, situated in a desert region near the California/Mexico frontier. In the irrigated, cultivated part (Imperial Valley) the frontier line can be discerned from the difference in density of the red zones (NASA photograph).

THERE IS ONE FIELD of research to which Europe has hitherto devoted only an insignificant effort, in spite of the relatively modest outlay it involves and the many economically attractive applications it offers: this is the observation of the earth's resources, also called ecographic observation, by remote-sensing processes.

Remote sensors, of which there are a wide variety, are devices by which long-range observations or measurements of an object can be effected, and from these one can deduce certain characteristics of the object observed. These devices, some of which are in everyday laboratory use, can be mounted in aircraft or spacecraft to take observations of areas of the earth's surface.

Although Europe has only shown a very marginal interest in these techniques, the United States has been working hard on them. For more than twenty years the Americans have been

using sensors on their aircraft or satellites for military espionage; for this purpose they developed specially adapted sensors and train experts to interpret the data collected by these devices. By 1962, however, the United States was already studying the non-military uses of remote-sensing systems. This research has been pursued intensively, but it lacks the spectacular character of certain other space operations, and in Europe only a few highly specialised circles followed its development. It has made such progress that by 1975 the United States will probably be able to start operating a system of ecographic satellites.

Fields of application of remote sensing

From the ecographic observations already effected with sensors mounted on aircraft or spacecraft, and from the first economic evaluations, it seems likely that these techniques will be valuable in a wide range of fields.

Agriculture:

- mapping of crops and assessment of yields;
- detection of diseased or parasite-infested crops;
- mapping of soil types;
- determination of soil humidity;
- detection of nutrient deficiencies in soils;
- location of new arable land;
- assessment of fire and flood damage.

Forecasting of natural disasters:

- forecasting of floods, tidal waves, volcanic eruptions, avalanches;
- sea search and rescue operations.

Forestry:

- identification of timber species in forests;
- detection of forest areas affected by disease or parasites;

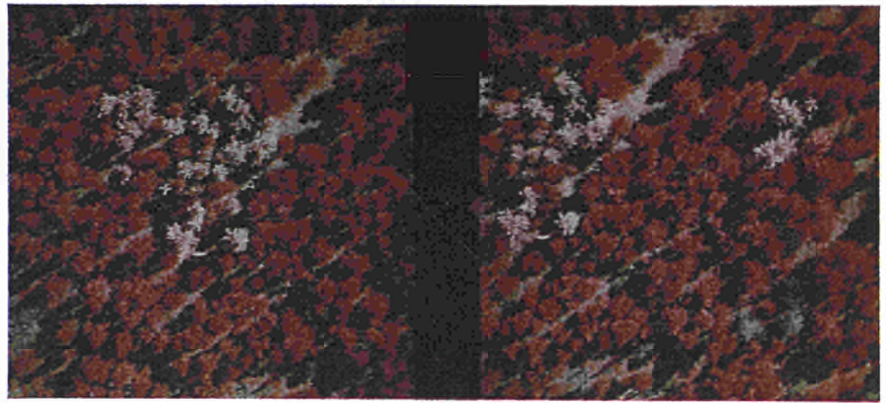
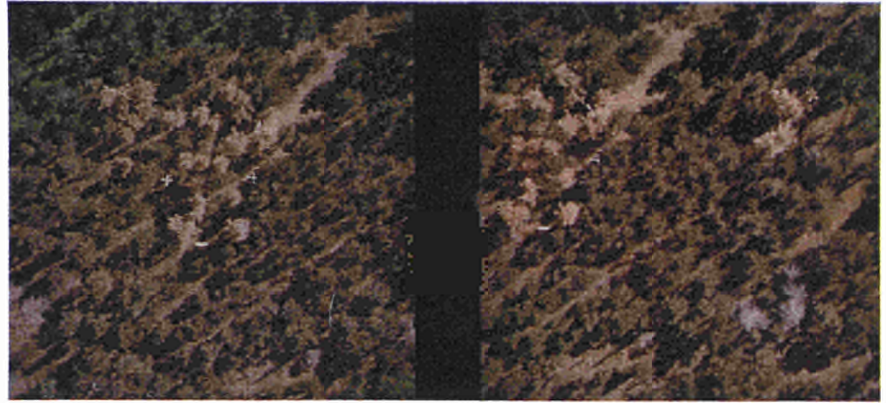

Fig. 3 shows natural-colour (top) and false-colour (bottom) photographs of a pine plantation attacked by a parasite. The affected trees, seen as white in the bottom picture, show up more clearly than in the top one (US Forestry Service photograph).

- detection of forest fires;
- planning of tree-felling programmes.

Environmental control:

- detection of sources of water pollution and measurement of its extent;
- detection of chemical and thermal pollution of water;
- measurement of the development of such pollution;
- detection of oil leaks.

Geological resources:

- detection of oil and mineral deposits;
- detection of underground aquifers;
- detecting thermal sources;
- study of off-shore sea-beds.

Hydrology:

- detection of water resources;
- surveying of glaciers and snowfields;
- measurement of river discharges;

- monitoring of silting in rivers and deltas;
- monitoring of irrigation networks.

Meteorology:

- weather forecasts;
- atmospheric thermal profiles;
- cloud cover and formation of cyclones.

Oceanography:

- shoal mapping;
- study of marine vegetation;
- detection of fish schools and study of their migratory paths;
- mapping of currents and temperatures;

Fig. 4: Identification of crops. This map was made from the data collected by a multi-channel scanning radiometer, in the 0.52-0.55, 0.55-0.58 and 0.58-0.62 micron bands.

These data, which were tape-recorded, were processed by computer and the output was requested in the form of a coded-colour map (University of Michigan photograph).

- Red: rice, well ripened;
- Blue: rice, at an earlier stage of ripening;
- Green: safflower;
- Black: bare ground.



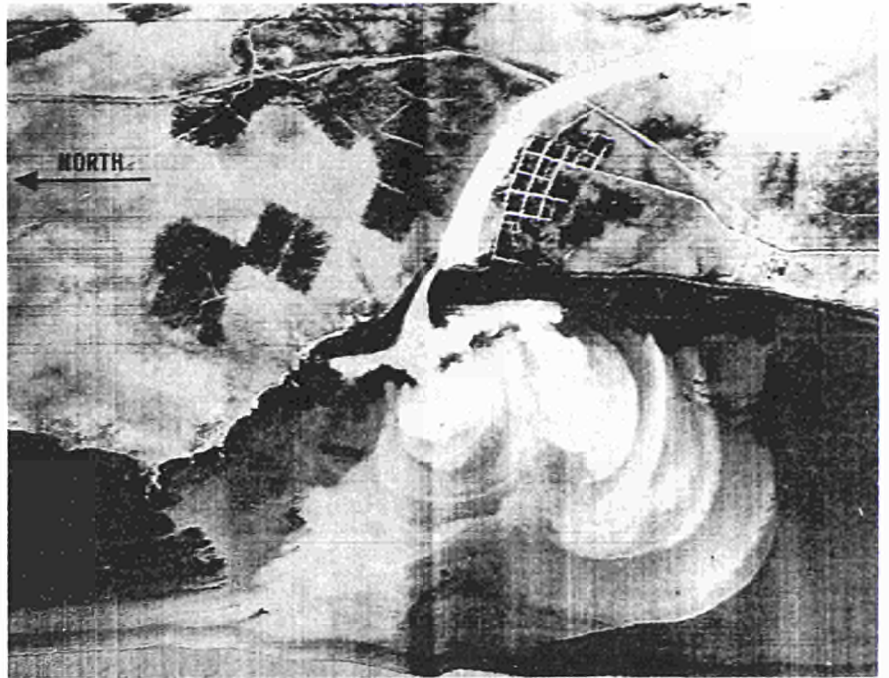

- checking on marine pollution;
- detection of icebergs.

Planning and surveying:

- cartography;
- town and country planning (settlement patterns);
- finding of sites for settlement.

The foregoing list is by no means exhaustive. Many applications are conceivable in such fields as transport, observation (counting and locating) of wildlife, scientific data (earth's energy budget, archaeological sites), etc. Other applications still unthought-of will undoubtedly emerge when these techniques are more widely used.

Present state of the art

Sensors are the essential devices by means of which ecographical observations or measurements are obtained. They are affected at long range by the different types of radiation emitted or reflected by the object observed, or they reveal variations caused by that object on its surroundings.

The sensing devices may be magnetometers, accelerometers, acoustic pick-

Fig. 5: Thermal pollution. *Infra-red picture of the mouth of the Quinault river in the Pacific Ocean.*

The concentric zones round the river mouth are due to the influence of the diurnal cycle on the temperature of the mass of water discharged each day (NASA photograph).

ups, cameras with or without filters, using black and white, colour or infra-red emulsions, TV cameras, likewise with filters, scanners working in ultra-violet, infra-red or radio frequencies, radar equipment, etc.

Some of these sensors, e.g. photographic emulsions, have been used for a long time; others are still being developed. They can be mounted on aircraft or spacecraft. Aircraft coverage of a given zone is expensive, and so cannot be done so often as with a satellite; on the other hand, it is more detailed. Thus the two methods, satellite and aircraft, would appear to be complementary.

The real problems to be solved before these systems can be used effectively for non-military purposes are as follows:

Orbital parameters	Set of three vidicon-tube TV cameras	Multi-spectral scanner
Type of orbit: heliosynchronous	Spectral band width (microns): 0.48 - 0.575 0.58 - 0.68 0.69 - 0.83	Spectral band width (microns): Channel 1: 0.5 to 0.6 2: 0.6 to 0.7 3: 0.7 to 0.8 4: 0.8 to 1.1 5: 10.4 to 12.6 (possibly)
Altitude: 912 km	Exposure time per image: 8.12 or 16 msec	Scanning: over the plane of the object (earth's surface)
Inclination: 99.088°	Reading time for this image formed on a memory tube: 3 sec	Scanning period: 65 msec
Period: 6 195.015 sec	Time interval between groups of images: 25 sec	Mirror efficiency: 65 %
Eccentricity: 0	Data: video-transmitted on 3.5 MHz	Detectors per band: 6
Duration of cover cycle: 18 days (251 revolutions)	Resolving power for a 1/10 contrast: 106 m in visible light 142 m in infra red	Data: in 5 Mb/sec pulse-coded modulation
Distance between two adjacent ground tracks: 160 km		Field of view: 70 × 70 m

Table I: Principal data on the orbit parameters and the satellite's two sensor systems.

—arousing the interest of potential users: As we have seen, these techniques cover a very wide range of activities, and so it is understandably difficult to arouse the interest of the people engaged in all the fields, make them realise how remote sensing can help them in their work, and then coordinate their needs so that they can be met by the simplest possible remote sensing assembly. This result seems to have been achieved in the United States, but Europe still has a long way to go;

—training of data interpreters: The data provided by the sensors need to be interpreted, i.e. an exact relationship must be established between the pictures or measurements obtained and the physical characteristics of the region they concern. This is far more complicated than the interpretation of

Fig. 6: Oil pollution. Views taken in the vicinity of a drilling platform in the Santa Barbara Channel. In the top picture, taken in visible light, the oil slick is not clearly visible; the white spot on the left near the platform is caused by chemicals used to disperse the slick. In the ultraviolet and infra-red pictures at the bottom, however, the extent of the slick is distinctly visible (University of Michigan photograph).



Panchromatic - K-2-Filter

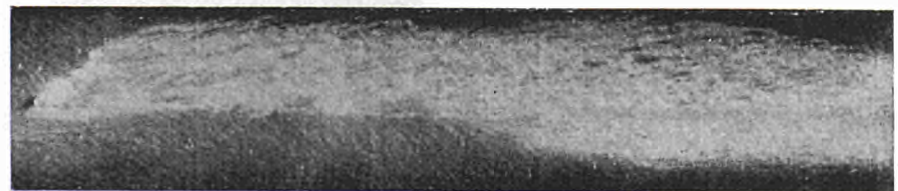

Ultraviolet - .32 to .38 μ



Infrared - 8.0 to 13.5 μ

conventional aerial photographs, because the phenomena to be analysed are not based solely on visible light. It therefore has to be done, on the basis of laboratory work and ground measurements providing standards, by specialists whose training takes several years and who are still non-existent in Europe;

—*utilisation of the results*: To ensure that the best use is made of the data obtained, efficient arrangements must be made to receive, analyse and format information and circulate it to users who can then plan their action accordingly. The United States has already made a good start on these lines, but nothing has yet been done about it in Europe.

Technical progress in the Western World

United States. For over 20 years the United States has been using sensors

and training personnel for its military requirements. In particular, since 1960 it has been launching *Discoverer* satellites at a rate of two or three a month. These satellites used to send back to earth the films they had exposed while orbiting, but since 1966 they have also been able to retransmit pictures to the ground by radio.

Non-military use of these techniques started in the United States in 1962. In that year the *University of Michigan*, which had long been working on remote-sensing methods for military purposes, called a meeting of civilian experts in various fields (ecologists, geologists, meteorologists, oceanologists, geographers, etc.) in order to explain the potential uses of these methods to them and to enlist their cooperation in a study of non-military applications. This meeting aroused such great interest that it was found worth while to hold an eighteen-monthly symposium which became an increasingly

important event. In 1966 the *U.S. Geological Survey* asked *NASA* to study the feasibility of building ecological satellites. *NASA* had started testing airborne remote-sensing devices as early as 1964, and it now initiated its *Earth Resources Survey (ERS)* programme. Interested enquiries flowed in from all sides. In the course of this programme *NASA* carried out sensor tests during the *Gemini* and *Apollo* flights and has done numerous surveys from aircraft. In 1969 it budgeted 12.2 million dollars for this work to which can be added certain "free services" (flying hours, for instance). *NASA* now has 70 teams of trained

Fig. 7: Geothermal studies. Two views of the Kilauea volcano (Hawaii), taken in visible light (top) and infra-red (bottom). The infra-red image gives a synoptic view of the temperature distribution on the volcano (the light parts are the hottest) (US Geological Survey photographs).

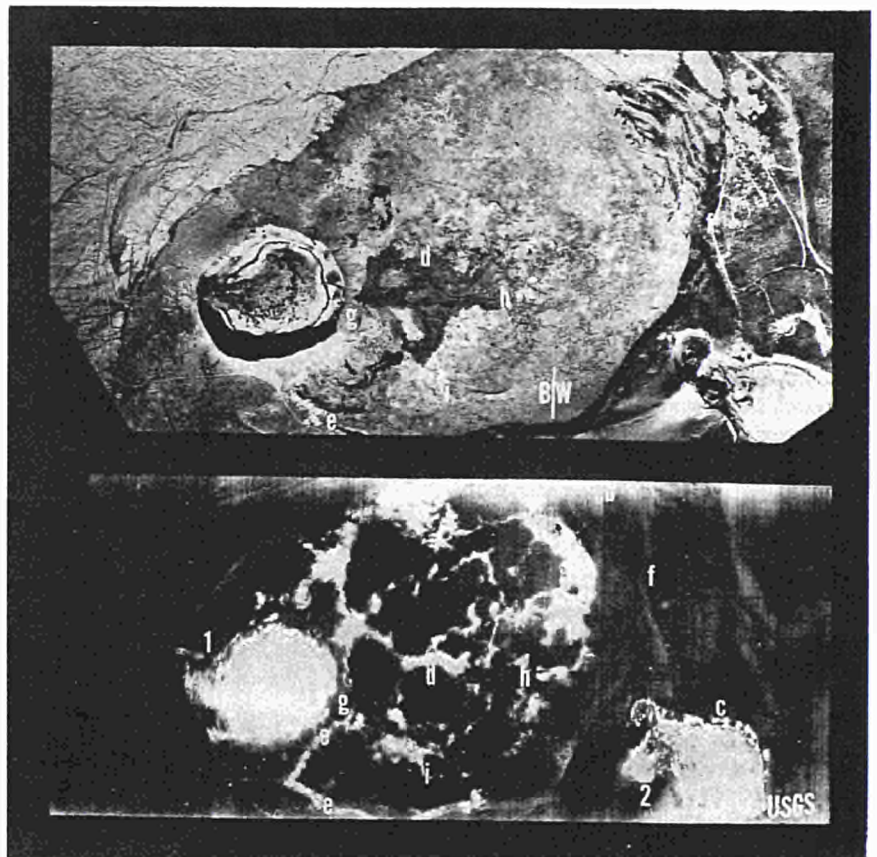
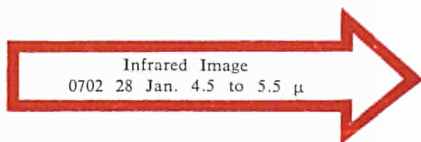
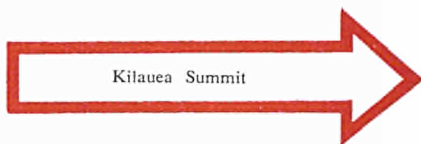

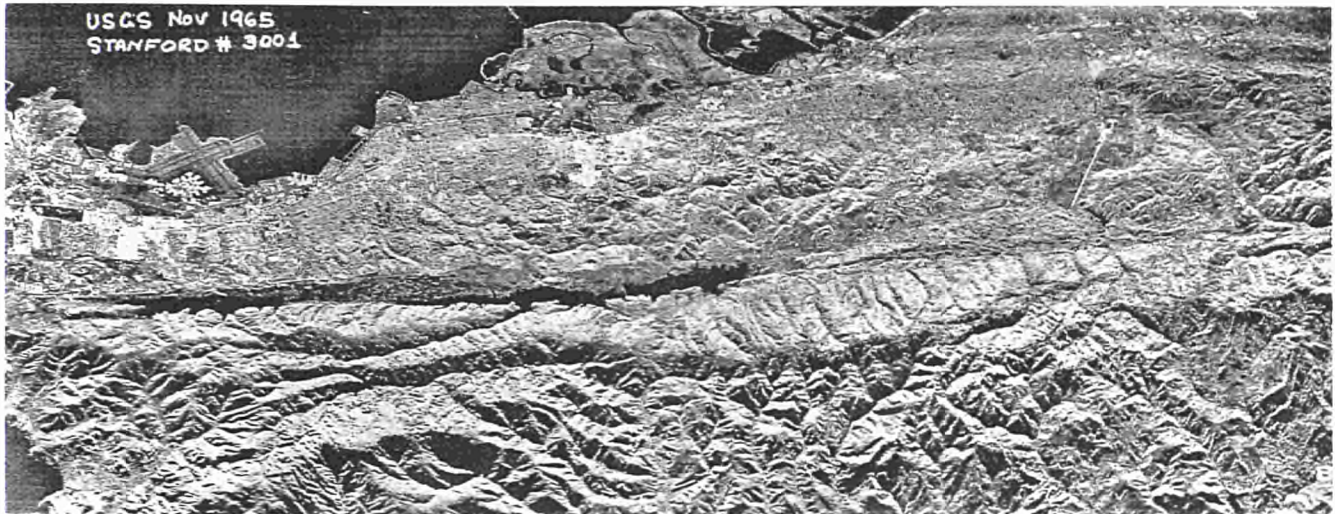

personnel, some of them working within its own organisation and others at universities. The preliminary observations have already been put to good use.

In July 1970 *NASA* awarded *General Electric* a 50-million-dollar contract to build two earth-resources satellite flight models and the associated ground stations. The first, *ERTS-A* (Fig. 1) is to be launched in 1972, followed a year later by *ERTS-B*. A one-year lifetime is specified. These satellites, which are intended primarily to cover a portion of the two Americas, will allow for furthering the development of the sensor devices, testing the methods of exploiting the information received and precisely assessing the services to be expected of them.

By the end of 1972, moreover, the *Skylab* orbital station will be in use for ecographic measurements. *After 1975 the United States may start to set up a network of operational ecographic satellites.*

In *Germany*, work started in 1969 on projects to develop sensors and evaluate their potential uses. It is proposed to test them in 1971 in aircraft flying over German territory. Three German aerospace firms have also been invited to tender for the preliminary design study of an experimental meteorological and ecographic satellite, to be launched about 1976.

In *France*, a sensor development and assessment programme is likewise in progress, under the auspices of the French *Centre National d'Etudes Spatiales (CNES)*. Series of observations with aircraft-mounted sensors were conducted over the Languedoc and the Paris Basin during the summer of 1970, and others in May 1971.

Three thousand photographs have already been taken and submitted to the research organisations or government bodies concerned. These runs, however, are still no more than an empirical approach to the problem; the sensors employed are of the kinds that were readily available in France, and the interpretation work is not backed up by a laboratory research effort.

In the *United Kingdom*, several universities are working on remote-sensing problems. Some useful devices, such as the side-looking radar and an infra-red scanning radiometer, have been developed for military purposes and are available for civilian work.

In *Sweden*, a national working party, which includes manufacturers and members of the armed forces and the universities, has been working for the last two years on remote-sensing problems.

ESRO (European Space Research Organisation) endeavours to arouse the interest of potential European users

Fig. 8: Geological studies. View of the San Andreas Fault in the San Francisco peninsula, taken by side-looking radar; this system builds up a picture by scanning a ground area with a radar beam transmitted obliquely to the ground from an aircraft. The beam is narrow in the direction of flight and elongated in the perpendicular direction. The ground relief can be reconstituted from the time lag in and the intensity of the echoes.

The San Andreas Fault runs horizontally across the picture; the dark patches in it are water-filled depressions. The high metal density in the urbanised coastal areas causes the white spots owing to high radar reflectance. The lines of trees along the road can be seen, and the grassy areas round the Stanford linear accelerator (long white line right of centre) show up as dark, with lighter points which have been checked as being trees (USGS photographs).

Fig. 9: Geological studies. Views taken at Seaside (Oregon) in visible light (left) and by side-looking radar (right). The vegetation effect (trees and grass), which predominates in the left-hand picture, is eliminated by the radar method, thus revealing the topography and structure. Note the waves breaking on the shore (NASA and USGS photographs).

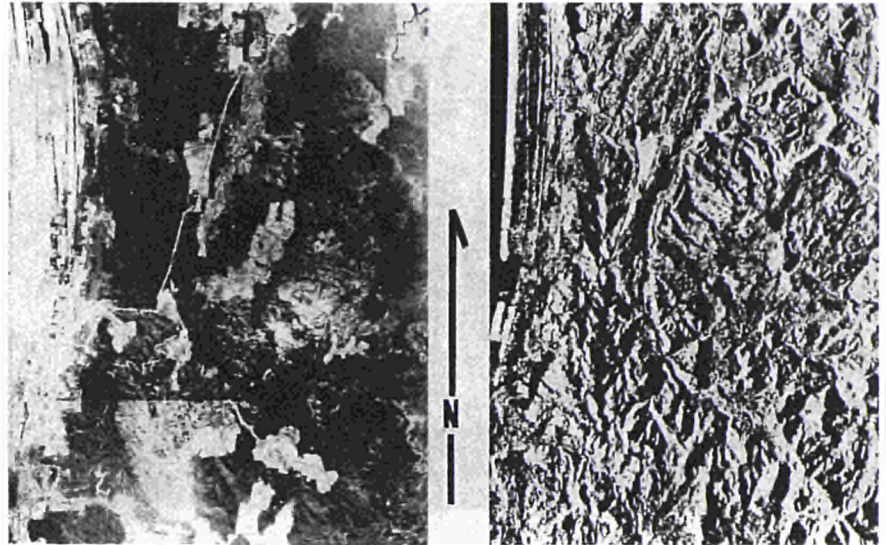

and keeps abreast of the work being done on the inventorying of natural resources all over the world, particularly in the United States. For the moment it is devoting a limited budget (several hundred thousand dollars in 1971) to preliminary studies.

Various bodies such as UNO, FAO and the World Bank are interested in remote-sensing techniques, especially with a view to their use on behalf of the underdeveloped countries. Under the Technical Sub-Committee of its Committee on the Peaceful Uses of Outer Space, UNO held a Panel at the University of Michigan in May 1971 on the use of sensors for observing natural resources, to which it invited representatives of the developing countries and of the organisations concerned with their problems.

Some illustrations of remote-sensing methods

Although the use of remote-sensing methods for ecographic observation has not yet reached an operation stage, some results obtained in the tests carried out to date are worth mentioning.

As regards prospecting for mineral resources, for instance, ore deposits are known to have been discovered in Australia as a result of observations made during Gemini flights.

In oil exploration, there are good reasons for believing that space observations played a part in two affairs.

A French company had explored for oil in the northern Chad by conventional methods and reached the conclusion that the geological structures of that region offered no promise. Two years ago, however, an American company took out an exploration licence

Fig. 10: Hydrology. Top, a view of a snow-covered area, taken in visible light, and, below, an infra-red view of the same area. The latter reveals the snow-covered boundary, which cannot be seen in the top picture, between the land and the frozen water (University of Michigan photograph).

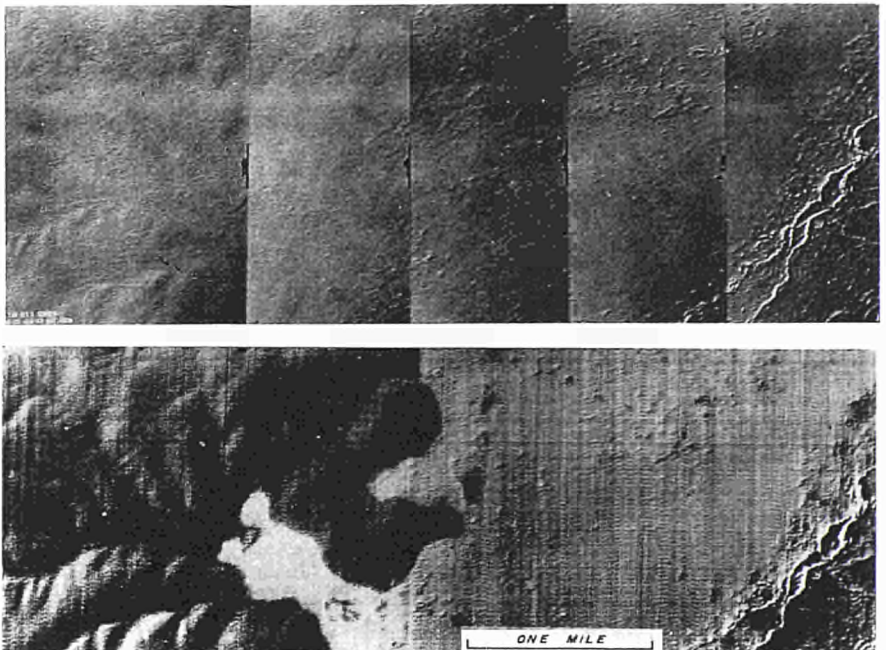

for 600 000 km² in the same area. Satellite information appears to be the only possible basis for this company's decisions.

An American group signed agreements with Algeria to obtain oil exploration concessions in that country on exactly the same economic terms as those Algeria had granted the French for the exploitation of petroleum deposits; this group must therefore have good reasons for hoping that its exploration will meet with success. Here too, it is impossible to see how such confidence was acquired except through satellite information.

The results already achieved in other spheres, and the form in which they are obtained, are illustrated in the figures accompanying this text.

Need for, and outline of, a European ecographic observation programme

It is difficult to gauge exactly how much advantage Europe could reap from the operation of an earth-resources observation system.

American estimates¹, however, give an order of magnitude for the annual benefit such a system could bring to mankind as a whole—44 000 million dollars and 52 000 human lives saved. Even if these figures are necessarily vague and probably exaggerated, the techniques are nevertheless of very great interest.

Surely, therefore, Europe ought to make a serious effort to become acquainted with these systems, which can be used in so many different fields. The scale of operation of an ecographic observation system should be not less than Community-wide, since the advantages increase with the area covered—particularly if the observation is done by satellite. As in the United States, users will come forward in Europe once the necessary research

and publicity effort has been made. But it can already be assumed that particular interest will be aroused by applications in mining and oil exploration—both in Europe and, especially, overseas—in aid to developing countries, in pollution surveillance and in the protection of man's environment.

The initial programme might cover four years and include:

1) *the organising of seminars* for specialists in the various subjects involved—geology, geophysics, ecology, meteorology, air and sea pollution, agriculture, hydrology, oceanography, cartography, land management—and for officials of the ministries and organisations which are operationally concerned in the application of these disciplines. It is essential to explain to these people how remote sensing can help them in their work. Only on these conditions can a programme be planned which meets genuine needs;

2) *the training of personnel* to interpret the data from remote-sensing systems. Europe has none. Interpretation training should be given to people who have already received basic training in one of the earth sciences;

3) *test runs* with aircraft. These should enable teams of technicians to familiarise themselves with the handling of sensors and, in collaboration with the interpreters, to determine the best conditions of use for obtaining a given result from sensors;

Fig. 11: Oceanography. *Photograph of the island of Jamaica taken by Apollo 9. Major north and south currents meet in the vicinity of the island; this can be seen from the differences of tone in the picture. Data of this kind, particularly if gathered in the polar regions, help to explain ocean movements (NASA photograph).*

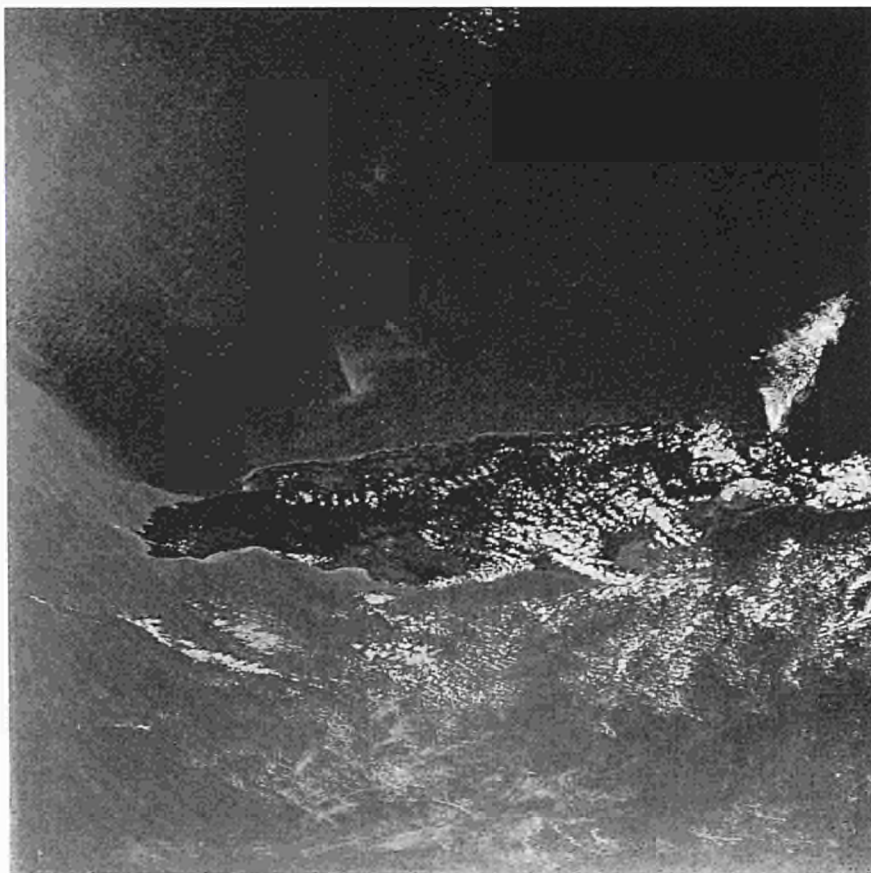

¹ Richard L. Legault: "Benefits from remote sensing"; report to CNES/University of Michigan Seminar; Paris, 4-6 November 1969.

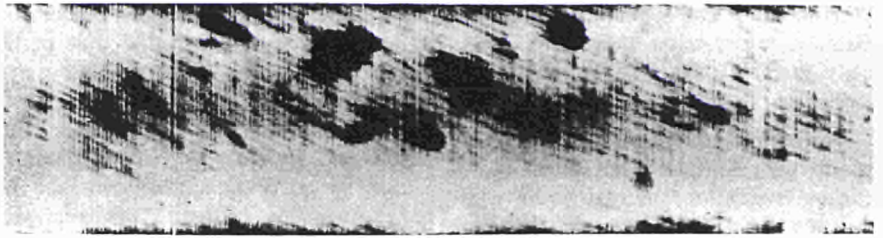

Fig. 12: Oceanography. This infra-red picture, taken at sea by night, shows dark patches which reveal the surfacing of colder waters, probably owing to turbulence caused by movements of schools of fish (University of Michigan photograph).

4) a supporting research programme, to be carried out both in the laboratory and in the field, with the primary aim of standardising the methods;

5) the creation of a coordinating body: this is essential in order to ensure the rapid launching of a coordinated programme to meet needs that probably vary widely, and then the management of the programme.

This task could be assigned to a Community office of a public-service character.

After the initial period a longer-term programme, possibly including the construction of satellites, could be

decided upon in the light of the requirements expressed.

The Member States of the European space organisations, though divided in their views on other matters, have declared a common interest in the development of applications satellites. They have given priority to satellites for telecommunications, air navigational aids and meteorology, in which there were declared immediate needs. It would seem opportune to consider ecological satellites as well; their economic usefulness appears to be certain, the technology is accessible, and users would undoubtedly come forward in response to a suitable publicity campaign.

EUSPA 10-10

*

The author particularly wishes to thank Mr Tessier of *ESRO* for providing the documents used to illustrate this article.

Fig. 13: Cartography. View taken by Gemini IV over Saudi Arabia; next to it is an ordinary geological map prepared from the photograph (Geotimes photograph 4/1/66).

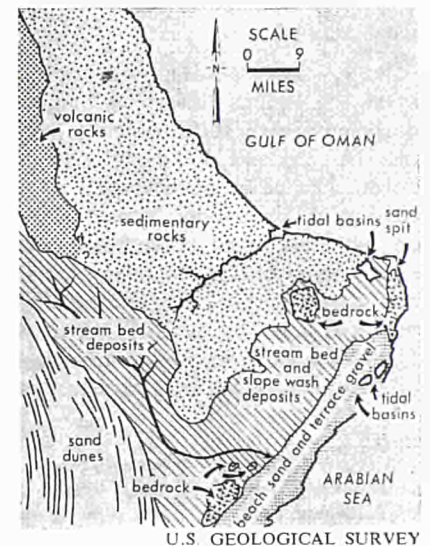
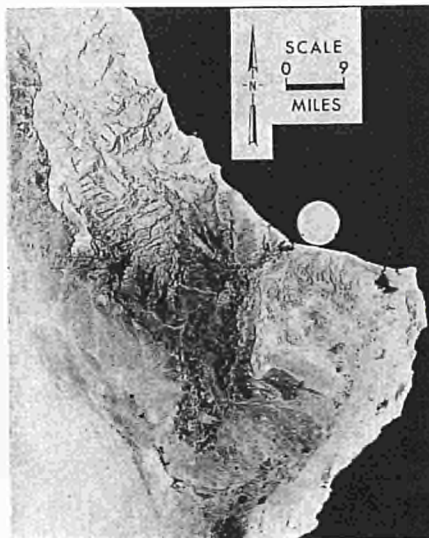

The creation of a Community system of radioactive waste dumps

GASTON GRISON

DURING the first two five-year plans, the Euratom Commission supported a number of research and development projects relating to the processing and disposal of radioactive waste.

Although some research on the processing of radioactive effluents¹ was successful, ultimately leading to industrial applications, the Commission's work was concentrated mainly on the dumping of waste and the problems directly associated with this². About 63% of the five-year budgets was allocated to this research.

Such a policy was justified because the methods of processing and casking low and medium-activity waste have developed rapidly and become industrialised during the last decade; on the other hand, the problem of nuclear "graveyards" did not receive sufficient attention, doubtless because at the time it was not so acute.

Forecasts of waste production

It can at present be estimated that in the European Community the annual production of low and medium-activity solid waste (coprecipitation sludge, evaporation concentrates and coated incineration ash, solid waste, compacted or uncompact etc.) is about 15 000 m³, the production of high-activity effluents stored in liquid form remaining low.

The problems raised by the diversification of energy sources, the supply

of oil products, the spectacular increase in the price of heavy fuel oil, the anxiety caused by excessive air pollution and the excellent performance offered by American power plants give grounds for anticipating a significant recovery in the nuclear power plant building programme.

Assuming a minimum development programme (40 000 MWe installed in 1980, 400 000 MWe in 2000), and on the basis of reasonable calculation

hypotheses, the evolution of the annual output of the various categories of waste can be forecast up to the year 2000. The characteristic points of this evolution are shown in Table I (the term "solid waste" includes all solid and solidified waste, i.e. waste which will ultimately be dumped).

It is necessary, in order to assess the scale of the problem, to take into account the accumulation of waste of the years to come (for the characteristic data of the trend in waste accumulation, see Table II).

The figures for deposits now dispersed over dumping grounds near research centres, power plants, processing and reprocessing plants, etc., as

¹ See *Euratom Bulletin* (1967), No. 1, p. 22-26.

² See *Euratom Bulletin* (1967), No. 3, p. 84-88.

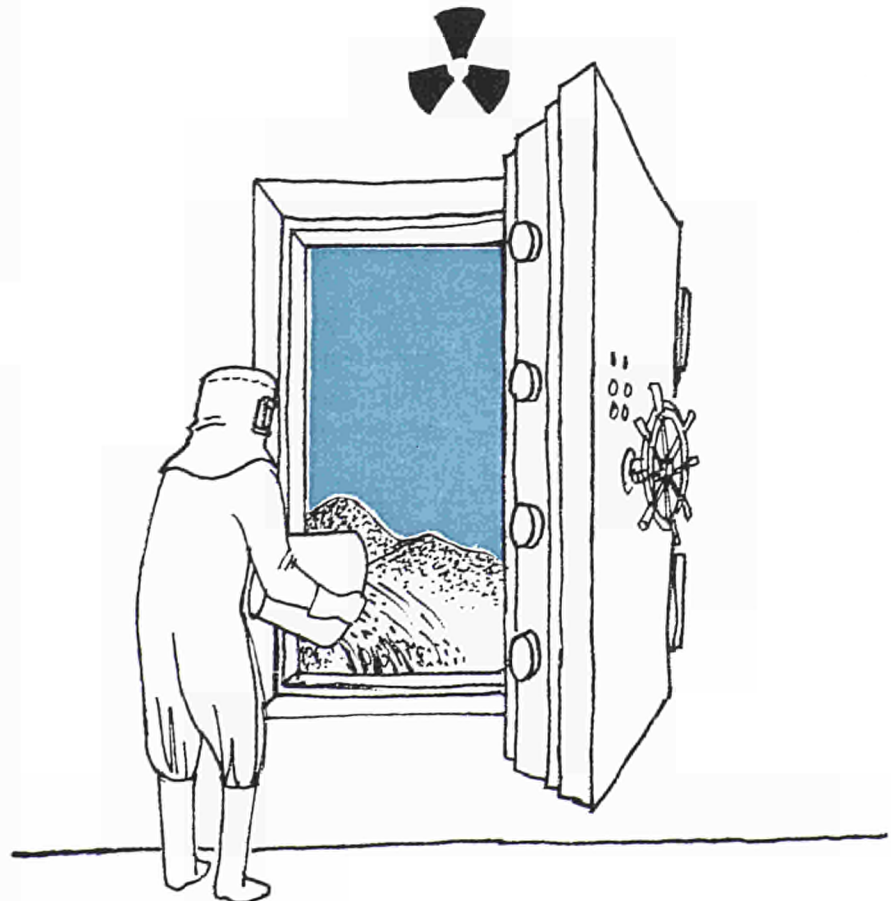

GASTON GRISON is a member of the Directorate-General for Industrial, Technological and Scientific Affairs of the Commission of the European Communities.

200

150

100

50

Forecasts of annual production in the Community of solid radioactive waste (in thousands of m³).

- Low activity
- Medium activity

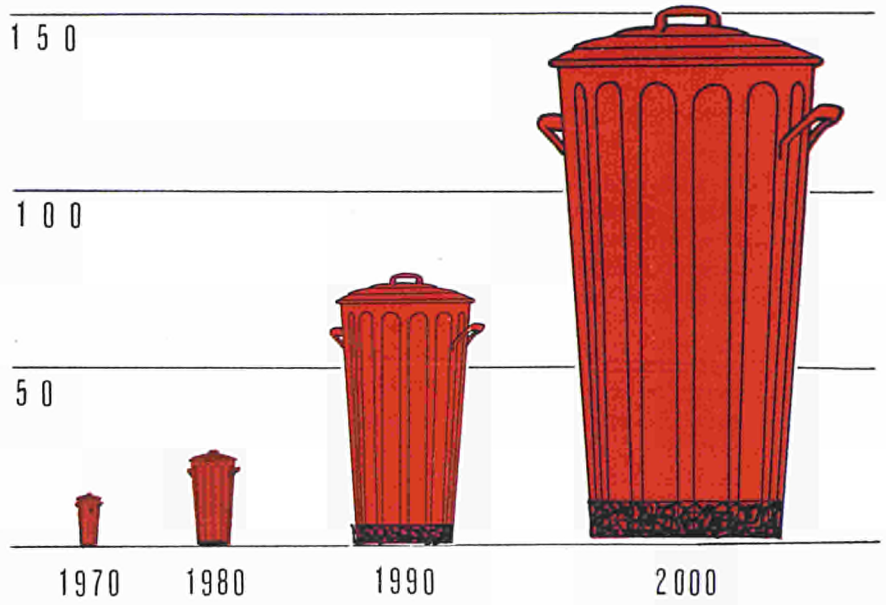

Forecasts of annual production in the Community of high-activity solid radioactive waste (in thousands of m³).

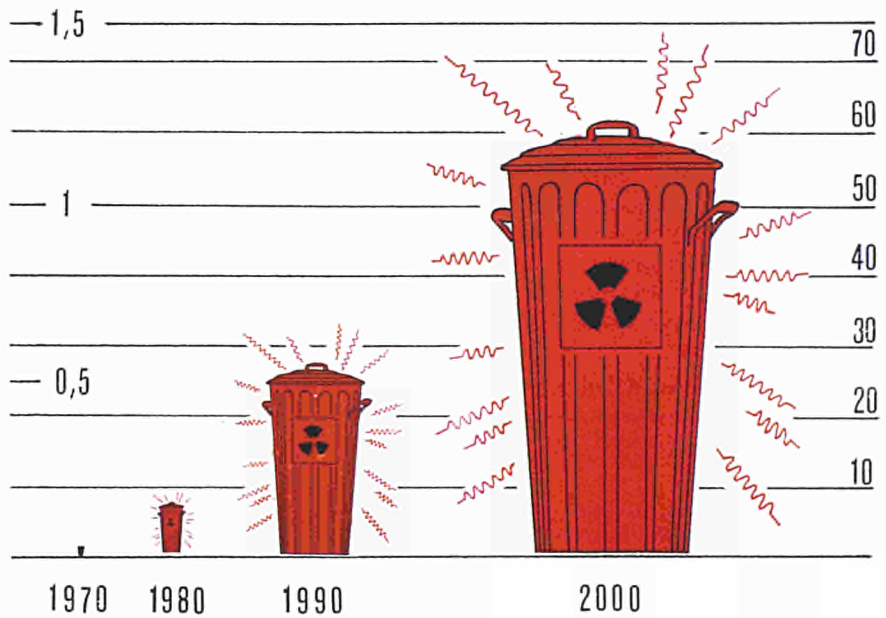

well as deposits on private sites, must be added to the figures given, though these deposits are of only minor importance compared with the foreseeable increase.

The radioactivity accumulated in the waste is difficult to evaluate since it depends on its age. In the report *EUR 3664* it was estimated, on the basis of simplified hypotheses, that the total residual activity in the year 2000 would be of the order of 300 000 million curies, contained in 3 000 tonnes of fission products. Although no doubt disputable, these figures do nevertheless give an order of magnitude of the activity to be dumped.

The production figures given for the various dates are, of course, only indicative and there may well be fluctuations covering several years, but it should not be forgotten that these results are based on a minimum programme of nuclear power production which anticipates an installed power of the order to 40 000 MWe by 1980. The probability of a more rapid expansion (60 000 MWe by 1980) had already been envisaged before the sharp increase in the price of heavy fuel oils during 1970 and the recent negotiations with the oil-producing countries. In Germany, for instance, the estimates for 1980 have risen from 16 000 to 25 000-30 000 MWe, and recently the figure of 50 000 MWe has been quoted. While there is uncertainty concerning the mapping out of an energy policy for the present European Community, the general trend can only be towards a substantial increase in the nuclear power programme, leading to a growth of the order of 50-100 % in waste production.

An idea of what can be expected in the European Community is provided by the example of the United States. The annual production of low and medium-activity solid waste in the United States is currently between 55 000 and 70 000 m³, whereas the installed nuclear capacity is only 5 000 MWe (note that waste processing rates are different in the United States). In 1975-80, for an installed capacity of at least 80 000 MWe, an annual waste production of 170 000 m³ is estimated,

	1970	1980	1990	2000
Low activity (in m ³)	13 100	26 000	75 000	150 000
Medium activity (in m ³)	1 600	3 000	7 000	15 000
High activity (in m ³) (in 10 ⁹ Ci)	13 0,6	130 6	500 28	1 200 60

Table I: *Forecasts of annual production of solid waste up to 2000. The rapid increase in production is noteworthy.*

55 000-85 000 m³ of which will come from nuclear power plants. This is the situation in which the Community will find itself towards 1985 if the Commission's minimum illustrative programme is fulfilled, and much sooner if the programme is extended as a result of international circumstances.

Creation of a Community system of dumping sites

From the foregoing it can be calculated that, less than 10 years after the United States, the European Community will be faced with a waste problem virtually equal to that with which the United States will have to cope in only a few years' time. In the United States a system of dumping sites has grown up rapidly since 1963. This system currently comprises five "graveyards" for low and medium-activity solid waste. Arrangements are in hand for opening the first dumping site in a salt mine, which will be reserved for high-activity waste and waste containing transuranium elements.

On the basis of the figures given previously, it can be predicted that, towards 1980, the Community will need

to have a system of dumping sites comparable to that which exists today in the United States.

This system of "graveyards", which should consist of general-purpose sites and more specialised sites (notably for high-activity waste, waste containing plutonium, etc.), is conceivable only on a scale larger than the present national one, for the following reasons:

1. To reduce the risk and cost of supervision, waste needs to be collected in a minimum number of sites. The larger the geographical scale, the better such a policy can be applied.
2. The map of existing nuclear installations shows that most of them are situated in areas along the line formed by the Rhine, the Jura and the Alps; this area broadly takes in the Community's internal frontiers; it would therefore be unreasonable to oblige some producers to use a very distant site in their own country when they could store their waste in a nearer site on a neighbour's territory.
3. The fuel reprocessing industry is currently organised on a European scale, so that reprocessing in one

Table II: *Accumulation of solid radioactive waste (in m³).*

Level of activity	1970	1980	1990	2000
Low and medium	13 500	225 000	780 000	2 000 000
High	20	650	4 000	13 000

member country of irradiated fuel from another leaves the former with non-national waste.

4. Some member countries, and very wide regions of other member countries, are probably unsuited to the installation of "graveyards", even if only for low-activity waste.

The objectives should therefore be to find a Community solution to the problem of storing radioactive waste, the sites being open to all producers, without distinction of nationality. The products would be stored for at least a few generations, depending on their characteristics, with a view to optimum safety.

Such a system of storage sites may be regarded as one of the "basic facilities necessary for the development of nuclear energy in the Community" as defined in the Treaty of Rome, not only from the technical and economic point of view but also from the health standpoint, for the protection of the general public—a further requirement of the Treaty.

The creation of such a system, by the studies it requires and by the concentration of harmful waste at a number of fixed points under strict supervision, is an undertaking which is also

connected with the problem of environmental protection.

At the colloquium on the disposal of radioactive waste held at Aix-en-Provence in September 1970, Mr Sous-selier of the French *Commissariat à l'énergie atomique* concluded his paper with these words:

"We then arrive at the idea of international cooperation in this field; the reduction in the number of storage sites, the optimum use of these in accordance with their individual characteristics and a clean environment for Western Europe all suggest that, at least for this part of the world, it would probably be desirable to consider some degree of internationalisation of these centres... Why should such things as "graveyards" for radioactive waste not also be subject to international authority?"

A similar idea had already been bandied about a few years previously at a select meeting of experts. No doubt this appeal was premature at the time, since there was no immediate need for "graveyards" then, but the statistics have grown and ways and means of instituting international cooperation should now be sought if we are to find valid solutions in the near future.

EUSPA 10-11



Technical Notes

— 44/C: Scanning loop

This equipment, known as the Model GS2 Scanning Loop, was developed at the Ispra Establishment of the *Joint Research Centre*.

It is housed in a double ESONE plug-in module, and is used in conjunction with a Model SC2 Scanner (see Technical Note 28/C), to scan high voltages in steps of 1/100th of the preset voltage.

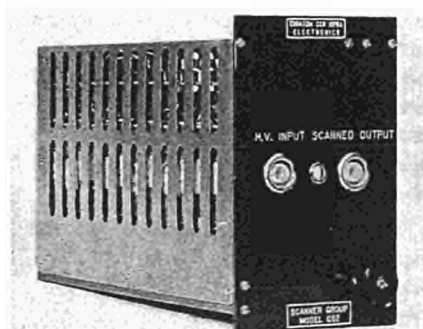

Maximum input voltage: 5 000 V.

Output value: 90 % of the input voltage.

The output impedance varies with the position on the divider up to a maximum of 1.3 MOhm, making the unit suitable only for use with very high impedance devices such as gas-cooled counters or ionisation chambers.

— 684: Core structure for a test reactor

The Ispra Establishment of the *Joint Research Centre* has designed a core structure for a test reactor with a low continuous rating, in which the temperature coefficient of reactivity is always negative. This is achieved by providing the fuel elements (1) with arrow-shaped ends whose points lodge between the large number of discrete elements (6) forming a restraint grid (2).

The grid elements are held together by means of an external restraining band (5) of elastic construction. If the core temperature rises, the fuel elements extend causing the aforesaid points to press further into the restraint grid. This causes the grid as a whole to

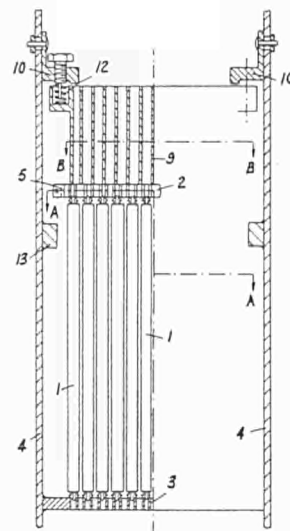

spread and increases the fuel element spacing so that the reactivity drops. The restraint band gives way at a defined limit load, so that the grid elements fall between the fuel elements and thereby trigger an immediate scram.

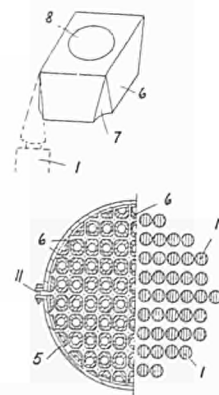

(British patent specification No. 1 151 356, French patent specification No. 1 490 831, German patent specification No. 1 276 829.)

— 959: Pressure measuring gauge

High response sensitivity is a feature of pressure gauge with a piezoelectric crystal at the tip.

The linearity of the readings obtained is often seriously affected, however, by resonances originating in the crystal mounting.

The Commission's *technical notes* give descriptions of original results obtained under the Euratom research programmes. Their purpose is to enable firms to decide whether they should consider industrialising these results.

On the basis of article 12 of the Euratom Treaty, a non-exclusive licence may be granted on the results covered by patents, in so far as the licensee is in a position to make effective use of these results. The conditions of the licence, as well as the royalties for technical assistance, will, for each individual case, be fixed after joint consultation.

Requests for additional information should be sent to: Commission of the European Communities, D.G. XIII-A, 29, rue Aldringer, Luxembourg.

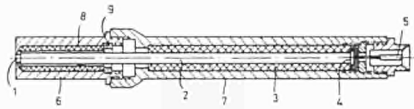

It is proposed that the crystal (1) be cemented to the end of an Al-Mg rod (2), only the rear extremity of which is mechanically secured and which simultaneously acts as an electrical connection (5).

The front surface of the crystal is only coated with a conductive compound, the other electrical connection being made via the gauge housing (7). The crystal is laterally located by means of a flexible insulating collar (8) the radial pressure from which can be adjusted by means of a screw (9) for the elimination of resonance.

This problem was solved at the Ispra Establishment of the *Joint Research Centre*.

(French patent specification No. 1 574 531, Dutch patent publication No. 68 11010, German patent publication No. 1 648 456.)

— 1017: Transistorised relay-control circuit

A large number of parallel relays impose a high inductive load on the driving circuit.

When the relays are deenergised, inductances generate pulses, particularly in fast transistorised driving circuits, which can destroy the power transistors.

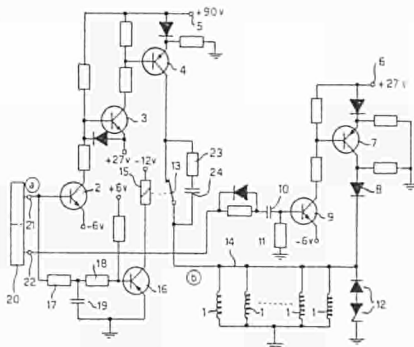

It is therefore proposed that the hold power (current source 6) for the relays (1) be supplied at a low potential from a separate transistor (7), and that

the endangered power transistor (4) providing the higher switch-on potential (current source 5) be isolated by means of an auxiliary relay (13 and 15) as soon as the relays have actually switched on.

The peaks occurring when the relays are deenergised are thereby prevented from reaching this transistor (4), yet the auxiliary relay (13 and 15) does not affect the response time of the transistorised driving circuit.

This development is the work of the Ispra Establishment of the *Joint Research Centre*.

(French patent specification No. 1 572 010, German patent publication No. 1 588 164, Dutch patent publication No. 68 10630.)

— 1105: Equipment for making α , β and γ autoradiographs

Since the film does not come into contact with the contaminated atmosphere and is protected against unwanted blackening by visible radiation, autoradiographs free of interference effects and contamination can be made with this equipment. The device is simple and easy to handle, giving top-quality autoradiographs. The exposed film is treated like a normal amateur film, being developed in a non-actinic dark-room.

- The equipment consists of:
- a film holder (1);
 - a box (2) shielding the film against α , β and γ rays;

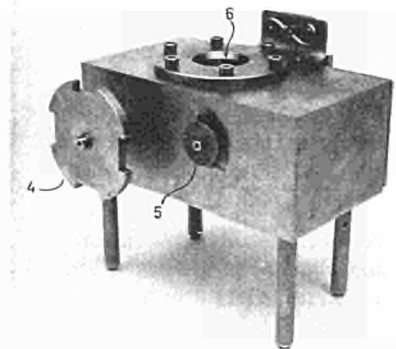

Equipment viewed from the hot cell.

—a flexible plastic tube (3) for protection against α and visible radiation during loading.

The following are its salient features:

—shielded loading and unloading of film;

—remote-controlled winding-on of film by means of an external drive wheel (4);

—winding monitor (5) outside box.

The equipment can be used for all types of autoradiograph work (e.g. metallurgy, metallography, biomedicine, etc.). In work with low-activity

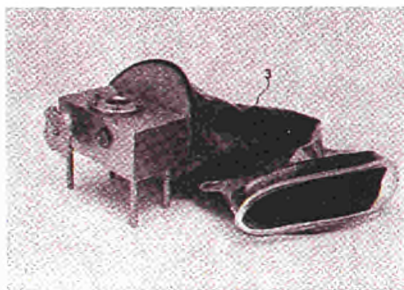

General view of equipment with flexible plastic tube.

specimens the equipment does not need to be enclosed in leaktight and/or shielded cells.

The following is a summary of the operating instructions:

—Place the film in the holder and push the carriage into the box;

—wind the film until the radiation-sensitive parts are in front of the specimen capsule (6);

—expose;

—withdraw film holder and develop.

(Belgian patent No. 702 864, French patent No. 1 578 489, British patent No. 1 196 190). The equipment is made under licence by the company of La Calhène, 5 av. Emile Zola, 95-Bezons (Val-d'Oise), France.

- 1) Film holder;
- 2) shielding box;
- 3) flexible plastic tube;
- 4) drive wheel;
- 5) winding monitor;
- 6) specimen capsule;
- 7) box cover.

— 1277: Sealed transport lock for radioactive materials

In hot laboratories small active samples have to be moved and positioned in instruments (e.g. microscopes) without the environment being contaminated in the process.

A transport lock has been developed for this purpose at the Karlsruhe Establishment of the *Joint Research Centre*. It consists basically of two cup-shaped chambers (5 and 6) rigidly interconnected by mechanical means,

with their rims pressing against a common end plate (7) so as to form a hermetic seal. Either chamber can be brought by rotation into alignment with an aperture normally closed by means of a cover (11).

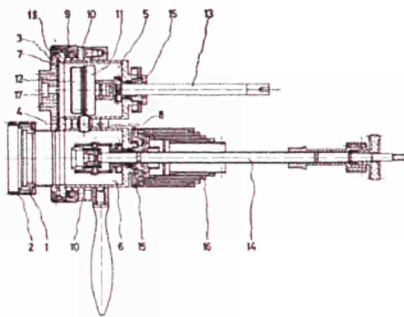

Manipulating arms (13 and 14) which pass through the ends of the cups into the chambers can be used to move the cover (11) into one chamber (5) and a sample into the other (6) when the container is connected to an instrument. Contamination of the outer surface of the container cover (11) is precluded by locking it to the cover (12) of the instrument sample chamber.

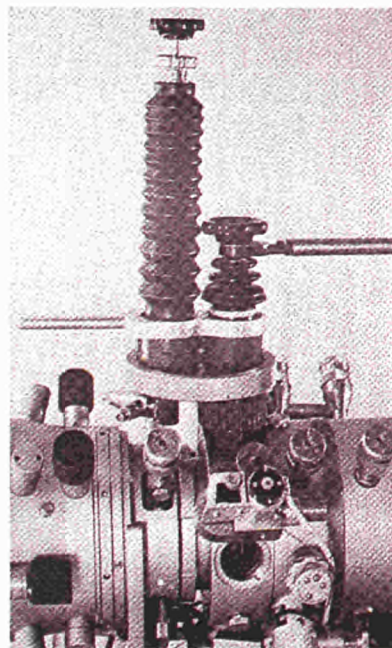

(Luxembourg patent specification No. 58 943, Italian patent specification No. 876 153.)

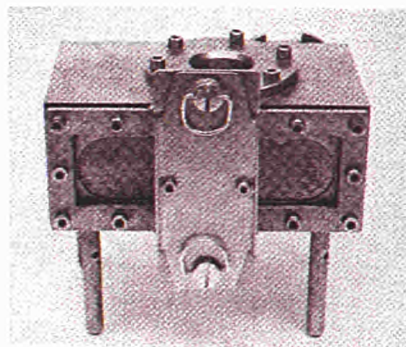

Equipment viewed from the connecting flange of the flexible plastic tube—box cover in place.

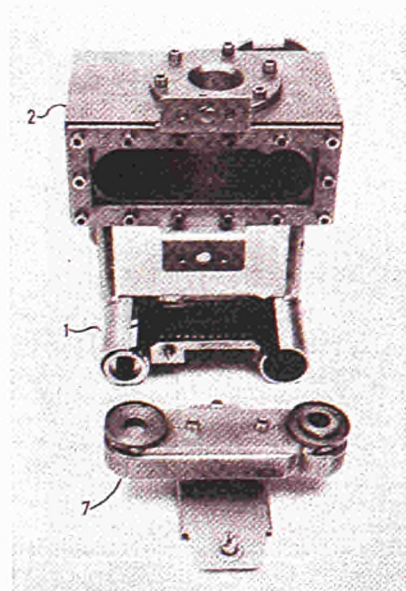

Equipment viewed from the connecting flange of the flexible plastic tube—box cover and film holder removed.

ca fysica physics c
 hemie chimie chimi
 ca chemie chemistr
 y biologie biologie
 biologia biologie bi
 ology medicin méde
 cine medicina gen
 eeskunde medicne
 werkstoffe matériau
 x materiali material
 en materials ingenie
 urstechnik und ger
 äte mécanique et ap
 pareillages ingeneri
 a e attrezzature tec
 niche mehanika en
 apparatuur engineer
 ing and equipment
 kernreaktoren réact
 eurs nucléaires reat
 tori nucleari nuclear
 reactors radioisotop
 e radio-isotopes ra
 dioisotopi radioisot
 open radioisotopes
 information und dok
 umentation informat
 ion et documentatio
 n informazione e do
 cumentazione infor
 matie en document
 atie information sci
 ence océanographie
 océanographie oce
 anografia oceanogr
 afie oceanography
 meteorologie météor
 ologie meteorologi
 a meteorologie met
 eorology Umweltbel
 ästigungen nuisanc
 es inconvenienti am
 bientali milieuhygie
 ne nuisances neue
 Verkehrsmittel moye
 ns de transport nuo
 vi mezzi di trasport
 o nieuwe vervoermi
 ddelen new means
 of transport informa
 tik informatique inf
 ormatica informatie
 verwerking data pro
 cessing fernmeldew
 esen communicatio
 ns comunicazioni c
 ommunicatie comm
 unications physik p
 hysique fisica fysica
 physics chemie chi
 mie chimica chemie
 chemistry biologie b
 iologie biologia bio
 logie biology mediz
 in médecine medici
 na geneeskunde me
 dicine werkstoffe m
 atériaux materiali m
 aterialen materials i
 ngenieurstechnik un
 d geräte mécanique
 et appareillages ing
 eneria e attrezzatur
 e tecniche mehanik
 a en apparatuur en
 gineering and equi
 pment kernreaktore
 n réacteurs nucléai
 res reattori nuclea
 ri nuclear reactors r
 adioisotope radio-is
 otopes radioisotopi
 radioisotopen radio
 isotopes information
 und dokumentation
 information et docu
 mentation informazi
 one e documentazi
 one informatie en d