

Research and Development on Radioactive Waste Management and Storage

First Annual Progress Report of the European Community Programme 1980-1984

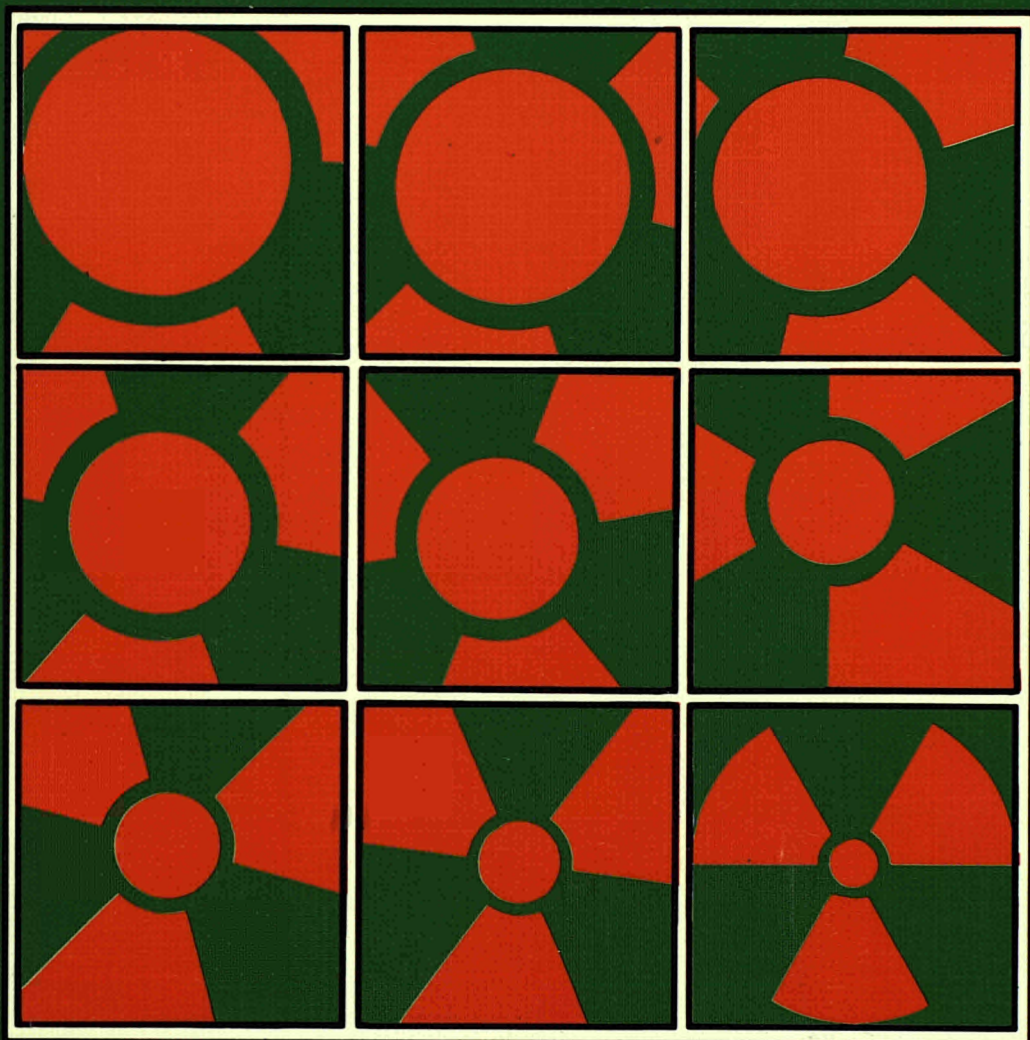

RADIOACTIVE WASTE MANAGEMENT
A Series of Monographs and Tracts
Volume 4

RESEARCH AND DEVELOPMENT ON RADIOACTIVE WASTE MANAGEMENT AND STORAGE

First Annual Progress Report of the European Community Programme 1980-1984

PARL. EUROP. Biblioth.

N. C.

Com. 38.756/1

RADIOACTIVE WASTE MANAGEMENT

A series of monographs and tracts

Editors : D. R. Anderson, Sandia Laboratories, A. M. Platt, Battelle Pacific Northwest Laboratory, F. Girardi, Joint Research Centre, S. Orłowski, Commission of the European Communities .

Volume 1

Radioactive Waste : Advanced Management Methods for Medium Active Liquid Waste

by K. W. Carley-Macaulay, R. G. Gutman, E. W. Hooper, J. A. Jenkins, A. D. Turner, P. F. Wace, P. Chauvet, J. P. Gauchon and T. Dippel

Volume 2

Radioactive Waste Disposal into a Plastic Clay Formation (A Site Specific Exercise of Probabilistic Assessment of Geological Containment)

by Marco d'Alessandro and Arnold Bonne

Volume 3

Management of Plutonium Contaminated Waste

edited by J. R. Grover

Volume 4

Research and Development on Radioactive Waste Management and Storage : First Annual Progress Report of the European Community Programme 1980-1984

Commission of the European Communities

Additional volumes in preparation

ISSN : 0275-7273 The publisher will accept continuation orders for this series, which may be cancelled at any time and which provide for automatic billing and shipping of each title in the series upon publication. Please write for details.

RESEARCH AND DEVELOPMENT ON RADIOACTIVE WASTE MANAGEMENT AND STORAGE

First Annual Progress Report of the European Community Programme 1980-1984

Publication arranged by :

Commission of the European Communities
Directorate-General Information Market and Innovation
Brussels and Luxembourg

Published under license by :

Harwood Academic Publishers GmbH
Poststrasse 22, 7000 Chur, Switzerland

Publishers' editorial office for the U.K. :

Harwood Academic Publishers Ltd.
61 Grays Inn Road
London WC1X 8TL

Publishers' editorial office for the U.S.A. :

Harwood Academic Publishers
P.O. Box 786, Cooper Station
New York, NY 10276

© ECSC, EEC, EAEC, Brussels and Luxembourg, 1982

EUR 7652

Legal Notice

Neither the Commission of the European Communities nor any person acting on behalf of the Commission is responsible for the use which might be made of the following information.

ISBN 3-7186 0115-X. ISSN 0275-7273. All rights reserved. No part of this work may be reproduced or utilized in any form or by any means, electrical or mechanical, including photocopying, recording, or by any information storage and retrieval system, without permission in writing from the copyright holder. Printed in France by Imprimerie PAILLART.

CONTENTS

	<u>Page</u>
FOREWORD	1
1. IMMOBILIZATION OF LOW- AND MEDIUM-ACTIVITY WASTE : DEVELOPMENT OF PROCESSES AND OPERATION OF PILOT INSTALLATIONS.....	4
2. CONDITIONING OF HIGH-ACTIVITY SOLID WASTE : FUEL CLADDINGS AND DISSOLUTION RESIDUES	13
3. TREATMENT OF MEDIUM LEVEL LIQUID WASTES	18
4. PROCESSING OF WASTE CONTAMINATED BY ALPHA EMITTERS ..	30
5. TESTING AND EVALUATION OF SOLIDIFIED HIGH ACTIVE WASTE FORMS	45
6. BURIAL OF LOW-ACTIVITY SOLID WASTE AT SHALLOW DEPTH..	52
7. STORAGE AND DISPOSAL IN GEOLOGICAL FORMATIONS	57
7.1. Introduction	57
7.2. Exploitation of deep drilling campaigns.....	61
7.3. Design and exploitation of underground experimen- tal rooms and shafts	64
7.4. Artificial barriers - Geochemical barriers, backfilling and sealing	76
7.5. Characterization of internal equilibria of geo- logical formations	83
7.6. Migration of radionuclides in the geological formation	98
7.7. Mathematical modeling	104
7.8. Risk analysis	111
7.9. Repository design	115
7.10. Improvement of methods for assessing the poten- tial of geological disposal	118
8. IMMOBILIZATION AND STORAGE OF GASEOUS WASTE	119
<hr/>	
ANNEX : MEMBERS OF THE ADVISORY COMMITTEE ON PROGRAMME MANAGEMENT	129



FOREWORD

This is the first progress report of the European Community's second programme (1980-1984) of research on radioactive waste management and storage (indirect action). It shows the status of the programme on 31 December 1980.

The Council of the European Communities adopted the second programme in March 1980*, as a follow-up of the first programme (1975-1979), considering :

"The (first) programme has yielded positive results and opened up encouraging prospects of attaining the desired objectives **. The particular nature of the waste is such as to require monitoring of its potential effects and reinforcement of the projects and research activities undertaken to ensure the protection of the environment".

The aim of the programme is the joint development and improvement of a management system of radioactive waste produced by the nuclear industry which, at its various stages, ensures the safety and protection of both man and his environment.

The programme covers :

- a) Work to solve certain technological problems involved in the processing, storage and disposal of radioactive waste.

Processing :

- immobilization of low- and medium-activity waste; development of processes and operation of pilot installations;

* OJ N° L 78, 25.3.1980, p. 22.

** See Annual Progress Reports (EUR 5479, EUR 6128, EUR 6650) and Proceedings of the First European Community Conference, Luxembourg, May 20-23, 1980 (EUR 6871).

- conditioning of high-activity waste : fuel claddings and residues from dissolvers;
- processing of medium-activity liquid waste;
- processing of waste contaminated by alpha emitters;
- examination and evaluation of high-activity solidified waste;
- immobilization and storage of gaseous waste.

Storage and disposal :

- burial of low-activity solid waste at shallow depth;
- storage and disposal in geological formations.

b) Work to define the general framework for the projects relating to the storage and disposal of radioactive waste.

As such, the second programme is a continuation of the first one. However, a few new trends have to be noted :

- a broadening of the studies dealing with low and medium activity waste;
- a special emphasis on the characterisation of waste products in view of their disposal;
- the addition to the studies dealing with the disposal of high level waste in continental geologic formations of preliminary studies dealing with the option of disposal into the seabed.

The programme is carried out by contracts on an expense sharing basis (indirect action) with qualified public or private agencies in the Community; the Commission's financial participation amounts to 43 millions European Currency Units. *

The Commission is responsible for managing the programme and is assisted in this task by an Advisory Committee on Pro-

* Conversion rate on 1.7.1981 :

1 ECU = 41.3 BFR/LFR	= 0.691 IRL
= 7.92 DKR	= 1256 LIT
= 2.52 DM	= 2.80 HFL
= 61.6 DRA	= 0.548 UKL
= 6.02 FF	= 1.05 USD

gramme Management, which consists of experts appointed by the Member States governments and of Commission officials*.

The programme is closely coordinated with the activities related to radioactive waste management conducted by the Joint Research Center of the Commission within its pluriannual research programme (direct action).

After the programme's adoption in March 1980, the work to be undertaken has been defined in detail, and research proposals have been called for and carefully examined and selected, project by project, for the period 1980-1982.

The professional staff in charge of the management of the programme during 1980 were :

L. CECILLE (part-time)
B. HUBER (part-time)
R. SIMON
P. VENET

with the assistance of C. COTTONE, C. EID, B. HAIJTINK, W. KRISCHER and W. FALKE.

The first progress report therefore covers the period of putting the Council decision into action and of initiating the research. It describes the nature and scope of the work being carried out under the various contracts and shows the orientation of the research projects; the first results will be reported in the next progress report.

S. ORLOWSKI
Head, Division
"Nuclear fuel cycle
and power industry"

* See Annex.

1. IMMOBILIZATION OF LOW- AND MEDIUM-ACTIVITY WASTE :
DEVELOPMENT OF PROCESSES AND OPERATION OF PILOT INSTALLATIONS

1.1. Introduction

The treatment of liquid effluents from nuclear power plants and other nuclear facilities produces substantial quantities of low- and medium-active waste. Most of these wastes can be conditioned to form waste packages which are acceptable for transport, long term storage and final disposal.

The primary objective of the first Community programme (1975-1979) was the construction, operation and evaluation of a pilot facility for the immobilization of reactor wastes with thermo-setting resins. This pilot plant has been commissioned and is operating.

There is also considerable scope for improving and widening the range of applications of existing conditioning techniques and for developing new methods for treating those wastes which it has not yet been possible to condition adequately.

It is also necessary to acquire comprehensive experimental data on the characteristics of industrially solidified waste which could be applied to select the most suitable process for each available disposal method and more accurately assess the environmental impact of waste disposal.

Generally speaking, the second programme will aim at :

- developing conditioning techniques to cover low and medium level wastes not adequately treated in the existing processes up to a pilot stage level;
- optimizing existing processes;
- identifying and measuring the characteristics which are desirable in immobilized wastes.

The last mentioned task will constitute a separate joint action (see Section 1.5) by laboratories concerned with the characterization of conditioned waste.

1.2. Incorporation of medium and low level wastes into cement

Proponent : UKAEA, AEE Winfrith Proposal : 166-81-15 WASUK

1.2.1. Aims and scope

The incorporation of low level radioactive wastes into a cement matrix for disposal is already practised, but, in the main, each plant is limited to a specific demand that has arisen at the operating site. There would be considerable value in the development of plant that could be used to incorporate a wide variety of wastes. The use of an inexpensive matrix material, such as cement, has obvious economic advantages where large volumes of low level waste are to be conditioned.

The research proposal presented here is part of a larger UK programme to develop and demonstrate a versatile cementation process. The research will identify formulations, based on commercial cements and mixing techniques which will allow a single unit to accept as wide a range of radioactive materials (slurries and solutions) as possible and produce cements for encapsulation of solids arising from plant maintenance and decommissioning operations.

1.2.2. Formulation trials

The aim of the laboratory scale programme is to broaden the variety of cement matrices available for incorporating radioactive waste. The programme will involve optimising the volume loading of radwaste in the radwaste/cement composites without detrimental effects on the durability (strength, permeability, dimensional changes) and leach rates. Various

radwaste cement products will be prepared and assessed for their short term properties and long term stability. This programme will involve the use of a range of commercially available cements and additives.

1.2.3. Cements

Initial trials will concentrate on the use of ordinary and sulphate resistant Portland cements. A comparison of the two types of cement will be made and the benefits of each for encapsulating various radwaste streams will be evaluated. Subsequently, replacement of the Portland cement constituent with other types of cementitious material will be assessed. Materials such as pulverised fuel ash and ground granulated blast furnace slag cement will be examined for their advantages of reducing the heat evolved during the hydration process and lowering the permeability of the final product.

1.2.4. Additives

Numerous additives have been identified as having beneficial effects on particular properties relevant to the solidification of radwastes in cement.

The cation exchange capacity of clays (bentonites, montmorillonites and micas) will be considered for the retention of caesium in the solid product. The other advantages of adding clays to radwaste/cement mixes will also be considered. These are the absorption of water in order to eliminate the bleed characteristics or to increase the volume loading of solutions and the thixotropic properties to facilitate transference of slurries.

The use of inorganic additives (e.g. sodium silicate, calcium hydroxide) will be studied for encapsulating certain wastes, particularly the citrate, oxalate and borate containing wastes.

Proprietary cement admixtures such as plastizers, set retarders and curing solutions, will be added in circumstances where changes in the fluidity, setting characteristics and curing conditions are required.

1.2.5. Mixing plants trials

A range of semi-process scale mixers (capable of mixing 200 l of cement) is available to determine their suitability for batch and continuous mixing. Three different types of mixers will be studied, i.e. in-drum, high shear and continuous mixers. The operating limits and efficiency of each type will be established. The experimental programme will involve measuring:

- throughput and mixing efficiency;
- mixing times;
- adaptability for a range of waste streams (solids, slurries and solutions).

The programme also includes examination of the operations and maintenance of the plant under remote handling conditions, with the aim of minimising the number of plant operations carried out under active conditions. The studies will include an assessment of the advantages and disadvantages, on a process scale, of pretreating the radioactive waste to optimise the volume loading and blending the cementitious materials to minimise the number of inlet feeds.

Preliminary laboratory formulation trials will be performed in order to define the appropriate physical and chemical characteristics (fluidity, bleed, heat of hydration and setting properties) of the fresh cement mix. The effects of these properties on plant operation will be established and subsequently their limits will be set.

1.3. Direct immobilization of medium active sludges and concentrates in polyester resin

Proponent : CNEN, Casaccia

Proposal : 164-81-15 WASI

1.3.1. Objectives

Most of the conditioning processes using polymer resins or thermoplastic materials as a matrix will require a partial or total dehydration of the waste prior to encapsulation. The proposed research action intends to demonstrate, on pilot-scale, an encapsulation process permitting the direct incorporation of evaporator concentrates and precipitated sludges in a polyester matrix.

The principal advantages of this process are the simplicity and ease of operation, the lack of drying or calcinating steps, the elimination of all problems related to the transport, dosing and buffer storage of powders or granules, and the absence of gaseous or liquid effluents and secondary wastes. The waste form obtained is expected to show considerable stability against radiation and physico-chemical attack, good mechanical properties and high fire resistance.

1.3.2. Work programme

The work programme will be carried out in two main phases :

- completion of the laboratory and pre-pilot scale tests in view of optimizing the process;
- design, construction and operation of an inactive pilot plant, with which the main process parameters and operating conditions can be investigated.

It is intended to study the encapsulation in polyester of the following waste types :

- medium and low active concentrates from fuel reprocessing;

- aqueous concentrates and/or sludges from research laboratories;
- evaporator concentrates from nuclear power plants;
- spent ion exchange resins.

The possibility of fixing certain alpha and tritium-bearing concentrates in polyester resins will also be assessed.

The influence of the following process parameters will be investigated :

- polymerization temperature and duration (for various catalysts and accelerators) ;
- waste/matrix ratio;
- agitation of the resin/waste mix ;
- shrinkage during setting ;
- effects of size ;
- interactions with container materials ;
- optimum plant capacity.

As far as possible a single resin formulation will be applied for all candidate waste types.

The reproducibility of the production and its quality control will be studied.

1.4. Medium and low level waste immobilization in polymer impregnated cement

Proponent : CNEN, Casaccia

Proposal : 165-81-13 WASI

1.4.1. Objectives

This proposal aims at the technical demonstration of an encapsulation process for medium and low level wastes, using resin impregnated cement as matrix.

It is intended to complete the laboratory investigations which had already been carried out for some time and to prove the representativity of the favourable results obtained to date in these tests. To this purpose an existing small pilot plant will be operated with simulated waste.

The polymer impregnated cement products have so far shown the following promising characteristics :

- leach rate comparable to bitumen and polyester ;
- mechanical properties superior to cement and bitumen ;
- more effective shielding than bitumen ;
- no flammability ;
- high waste/matrix ratios (0.65-0.75).

The process will also produce little secondary waste.

1.4.2. Work programme

During the first phase the lab- and bench-scale experiments to define the process will be completed. These experiments will permit the improvement of the flowsheet and, during the second phase, the design, construction and operation of an inactive pilot plant.

The aim is to condition the following waste types :

- evaporator concentrates from reactors and research establishments ;
- nitrate containing medium active wastes from reprocessing ;
- spent ion exchange resins.

It should also be possible to incorporate certain alpha-bearing residues from mixed oxide fuel fabrication and fuel cladding wastes into polymer impregnated cement.

The investigations about operating conditions will cover:

- setting temperature and pressure ;
- waste/matrix ratios ;

- duration of the cement setting, the impregnation and the polymerization ;
- polymerization temperature ;
- effects of form and dimension.

This information will be used to design a pilot plant. An inactive pilot plant is planned to be operating by the end of 1982.

1.5. Joint programme on characterization of medium level and alpha waste forms

Whereas the first five-year programme concentrated on treatment methods for medium level and alpha waste, the second programme calls for an important effort in the field of waste form characterization.

A working group (1 C) set up to define a joint programme for testing conditioned medium level and alpha waste, agreed on the following schedule :

- A review of all available data will be carried out until 25 February 1981. A common format for the presentation of the data was adopted.
- On the basis of the review, the prime objectives and priorities of the R & D activities to be undertaken will be defined.
- A coordinated programme of testing the relevant properties of a number of reference waste products will be established in June 1981.

The main object of this joint programme will be the characterization of waste forms obtained by immobilizing :

- evaporator concentrates (from reactors and reprocessing),
- ion exchange resins,
- reprocessing and fuel pond sludges,
- miscellaneous solid alpha wastes,

in matrix materials such as bitumen, cement, polymer resins, ceramics and slags.

The following subjects have been tentatively identified for possible inclusion in the experimental programme :

- effect of waste composition (inhomogeneity) ;
- applicability and reproducibility of test methods ;
- effects of scaling-up ;
- radiation effects (radiation damage, radiolysis) ;
- leaching studies (parametric, basic mechanism, actinide specific) ;
- microbiological attack and its consequences ;
- shrinking/swelling ;
- ageing effects ;
- compatibility waste form/container ;
- mechanical properties (technical and real) ;
- thermal effects including freeze/thaw cycle ;
- fire consequences.

2. CONDITIONING OF HIGH-ACTIVITY SOLID WASTE : FUEL CLADDINGS AND DISSOLUTION RESIDUES

2.1. Introduction

The Zircaloy and stainless steel claddings of spent fuel elements and the dissolution residues from the first process step of fuel reprocessing have a high specific activity and a substantial content of transuranic elements.

Several methods for the conditioning of these wastes have been studied under the first Community programme (1975-1979) namely:

- press compaction and embedding in lead of cladding waste ;
- roll compaction and embedding in concrete of cladding waste;
- decontamination by molten glass and volume reduction by means of eutectic fusion of cladding waste
- embedding of cladding wastes in glass ;
- embedding of alpha residues in ceramics ;
- cryogenic crushing and lixiviation of alpha contaminated wastes.

In addition, the typical radioactivities associated with spent fuel claddings have been characterized, including their tritium content. A state of the art study on cladding waste management has been undertaken.

The most promising conditioning methods were selected for being further developed under the second programme. This work includes the waste product testing required during the development of the conditioning processes.

The main objectives of the second programme have been stated as follows :

- active demonstration of methods for conditioning of cladding waste ;
- investigation of the pyrophorocity of Zircaloy fines ;

- assessment of the contamination of a representative sample of cladding waste from industrial reprocessing;
- development of methods for the embedding of dissolution residues and other types of alpha waste in a sintered ceramic matrix.

2.2. Cladding waste press compaction and embedding in a lead alloy matrix

Proponent : CEN/SCK, Mol

Proposal : 167-81-2 WASB

With a view to the further development of this conditioning method, the major effort will be put on the construction and operation of a hot cell pilot facility. This will allow verification of the process capabilities with active claddings and provide operating experience with respect to the technology involved, primarily concerning compaction.

Design of the equipment will be based on experimental and conceptual studies performed under the first programme. The scale proposed is sufficient for extrapolations in view of industrial applications. It is planned that the facility will be operational at the end of 1982. Experimental work with active hulls is planned for 1983/84.

Laboratory studies aiming at the assessment and selection of embedment alloys of high quality will be carried out during 1981 and 1982 to complete the investigations undertaken under the first programme.

2.3. Characterization of the cladding/cement product

Proponent : KfK, Karlsruhe

Proposal : 168-81-2 WASB

The work performed under the first five-year programme will be

complemented and terminated by characterizing the physico-chemical properties of the cement material containing the spent fuel hulls. This compound will be tested with respect to gas release from active cladding waste containers from the WAK reprocessing plant and especially concerning the observed tritium emanation. Other tests will be performed in order to measure the leaching behaviour of the product and to determine the temperature distribution (calorimetry) in WAK-containers.

2.4. Conditioning of cladding waste by embedding in a metal or graphite matrix

Proponent : Nukem, Hanau.

Proposal : 169-81-2 WASD

It is proposed to condition spent fuel claddings by embedding in a metal or graphite matrix by means of powder metallurgical technology. Both processes are well known in the production of fuel elements for HTR and MTR reactors. A stainless steel die is filled with cladding pieces and pressing powder. Then the mixture is prepressed and densified at room temperature. After coating the prepressed cylindrical block with a prepressed waste-free shell in a second die, the content of this die is pressed to a compact, high-dense, and very corrosion-resistant block. For both processes - embedding in metal and graphite matrix - temperatures of about 130°C are sufficient. In the case of the graphite matrix reaction temperatures of 400-450°C have to be applied subsequently.

At the end of 1982 both processes will be compared in order to select the best for remote handling in hot cells.

2.5. Conditioning of cladding waste by eutectic fusion and by embedding in glass

Proponent : CEA, Marcoule

Proposal : 170-81-2 WASUK

Laboratory work will be carried out in hot cells for two methods

of conditioning cladding wastes : eutectic melting and embedding in glass. A decontamination technique will be investigated simultaneously for the first process. The final products will be submitted to physico-chemical testing for determining their properties in view of disposal. The phenomena occurring during the process steps will be studied.

2.6. Conversion of Zircaloy cladding to zirconium oxide

Proponent : UKAEA, Harwell

Proposal : 171-81-2 WASUK

The process to be developed is conversion of Zircaloy to chemically inert zirconium oxide (zirconia) by reaction first with ammonium fluoride to produce a zirconium fluoride complex and subsequent reaction of this with ammonium hydroxide. In this way the bulk of ammonium fluoride liquor can be recycled and does not appear as a liquid waste. Small scale studies leading to a definition of the flowsheet have already commenced and a small pilot plant is under construction (work not funded by the Community). This would be operated to determine the behaviour of solids and activity and the values of main chemical engineering parameters, which define the size of plant items. Formulations to embody the zirconia in a massive form will be developed and tested.

2.7. Incorporation of cladding waste in a ceramic matrix

Proponent : CEA, Saclay

Proposal : 172-81-2 WASF

A method will be defined to incorporate the dissolution residues and claddings of PWR and FBR fuel into ceramics. The work consists of the following steps :

- specification of the characteristics and selection of the ceramics under consideration as matrix materials (alumina, vitreous ceramics);

- production of compacted waste/matrix cylinders on laboratory scale with 100 to 200 mm diameter and 200 to 300 mm height;
- characterization of the obtained materials : texture, homogeneity, mechanical properties, thermal conductivity.

2.8. Incorporation of alpha bearing waste in ceramics

Proponent : KfK, Karlsruhe

Proposal : 173-81-2 WASD

This proposal concerns the development of a process for incorporating alpha wastes in a ceramic matrix. It is studied how the solidification products can be prepared. Their main characteristics are determined aiming at the description of the optimum composition, regarding leach resistance, mechanical strength, homogeneity, porosity and radiation stability. Included in these experiments is the behaviour of the waste components with respect to their reactions and their volatilization during the sintering process.

All results obtained in inactive experiments with simulated wastes will be checked with real alpha wastes so far as they are available. Alpha-doped simulated are used as alternative.

To develop a technical process for fabricating ceramic pellets with alpha wastes, the necessary equipment is selected and/or adapted for remote operation. The main steps of the process are mixing, pellet forming and pellet sintering. Furthermore the behaviour of the wastes in the transfer from tanks to the plant components and in between them will be studied. The investigations will result in the full description of a technical process.



3. TREATMENT OF MEDIUM LEVEL LIQUID WASTES

3.1. Introduction

Community research on the treatment of medium level liquid waste is a new project, since this subject was not included in the first (1975-1979) programme.

The medium activity liquid wastes (MAW) encompass a broad spectrum of wastes varying widely in chemical and radioactive content (see Figure 3.1.). Most of them are produced in re-processing plants and their nature, composition and volume strongly depend on the plant flow-sheet. Other MAW streams arise from nuclear power plants and concern mainly liquid contamination and other utility wastes. Various liquid wastes generated in the fabrication of mixed oxide fuel can be also classified as MAW sources.

Medium active wastes from reprocessing contain sufficient radioactive material to warrant shielded and remotely operated treatment facilities and a relatively high potential for significant transuranium elements contamination. In fact, whereas their fission products content is at least two orders of magnitude less than in high level wastes, their alpha emitters content is in the same range. Therefore, the disposal of the conditioned MAW into geological formations must be considered. As waste disposal into certain geological formations, e.g. clay and granite, is expected to be expensive and taking account of the large amounts of conditioned MAW with respect to solidified high level waste (20 to 40 times more in volume), liquid MAW management represents a critical aspect within the overall nuclear waste management. Moreover, the development of reprocessing plants in the near future will entail more and more stringent safety requirements for re-processing wastes.

31

32

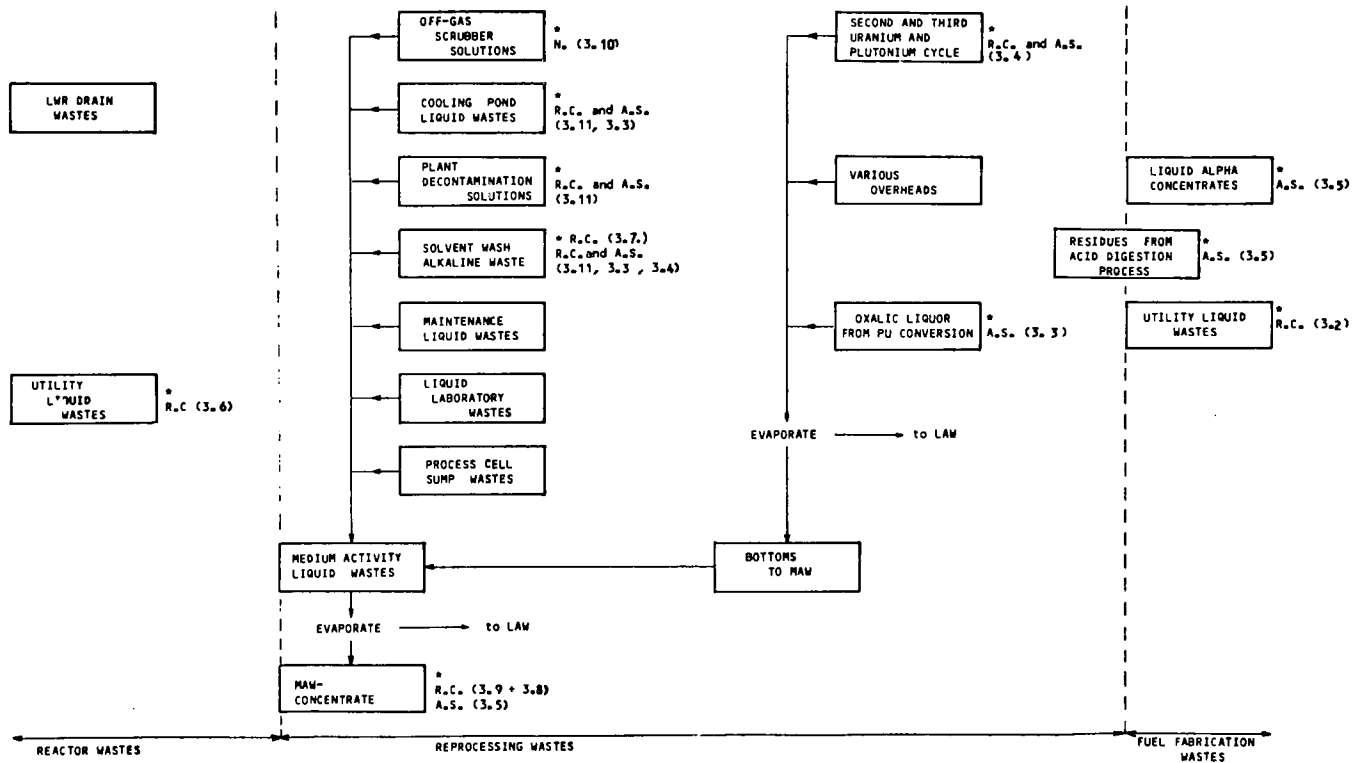

* Subject of the Community programme (the number in brackets refers to the corresponding section of this document)

FIG. 3.1. : MAIN AQUEOUS MAM STREAMS

R.C. : Radioactivity concentration strategy
 A.S. : Actinide separation strategy
 N. : Reduction of nitrates

Therefore, the necessity of improving MAW treatment methods is - besides the necessity of improving reprocessing flow-sheets - being felt with a high degree of urgency.

The basic strategy for improving liquid MAW management is to split the waste into ~

- a small stream, which contains most of the radioactivity and is subsequently conditioned together with the high level waste, and
- a large stream of low activity, especially with regard to alpha emitters, which can subsequently be treated as low-level waste.

This basic strategy may, where appropriate, be supplemented by treatments aiming at separation of plutonium, for recycling, or separation of the actinides, for subsequent special conditioning.

Ion exchange and chemical precipitation techniques, although already extensively studied for treatment of various radioactive wastes, still require some improvements to be applied to the specific problem of MAW. According to the review study of potential advanced methods for the treatment of liquid MAW, carried out under the first Community programme (1975-1979), the following main subjects have been selected for more detailed study and/or development :

- ultrafiltration, particularly in combination with a chemical treatment to produce minor quantities of precipitate;
- new organic ion exchangers as they become commercially available and particularly in relation to separation of alpha activity;
- adsorption techniques for the treatment of activity in undissociated species;
- inorganic ion exchangers for specific separation of activity and in relation to their potential for immobilization;

- washing and de-watering techniques for flocs and sludges;
- methods for decreasing the total inactive salt content (denitration and catalytic reduction of nitrates);
- a more basic experimental study of electrical processes in the context of treating active waste liquids, combined with continued assessment of their potential.

The research actions for each MAW source are shown in Fig. 3.1. as well as the respective strategy (concentration of activity or actinide separation). Since contract negotiations are still going on, some modifications in the orientation of the contracts may yet be made.

3.2. Decontamination of low activity liquid wastes arising from fuel fabrication plants by means of ultrafiltration technique

Proponent : Nukem, Hanau

Proposal : 230-81-35 WASD

This proposal intends to investigate how far ultrafiltration using membranes with 0.01 μm diameter pores can decontaminate liquid wastes from a fuel fabrication plant (uranium-thorium fuel cycle).

Ultrafiltration techniques will be tested by means of a bench scale unit (8 L/h capacity) on various liquid waste sources such as :

- buildings cleaning waste,
- decontamination solutions of plant components,
- laundry waste solutions.

These liquid wastes are fairly low-active but arise in considerable volumes. Their chemical composition is very varying and they may contain dust, fluff, oils, greases, tensides and

phosphates. Therefore tests will be carried out to determine which waste types can be sent directly to the ultrafiltration unit for a thorough decontamination and which waste types require a pretreatment consisting of filtration, centrifugation, emulsion cracking or flocculation. After this selection, the operating conditions for ultrafiltration and pretreatment will be optimized.

In the second part of the programme, it is foreseen to test this technique with different supernatant solutions coming from centrifugation operations.

3.3. Active liquid treatment by a combination of precipitation and membrane processes

Proponent : UKAEA, Harwell

Proposal : 179-81-31 WASUK

The aim of this programme is mainly to investigate the potential of ultra-filtration techniques used in combination with flocculation processes for the treatment of medium active liquid wastes.

The basic technique to be studied is the combined use of precipitants with available types of ultrafilters. The precipitant is added to the waste stream which then passes over the ultrafilter, a purified permeate emerges as a product and the residual concentrate is recycled for settling and/or further ultrafiltration treatment.

The programme consists of the following main actions :

- identification of the main parameters acting on the process;
- membrane tests (flat sheet membrane and commercial modules)
- membrane irradiation tests;
- batch tests using real MAW solutions;
- continuous operation tests;

- flowsheet and plant concept studies;

It is intended to examine the treatment of various types of MAW by this technique, e.g. :

- Magnox fuel pond waters;
- Magnox fuel dissolution liquors;
- carbonate solvent wash liquors;
- plutonium oxalate precipitation mother liquor.

The research activity will start with simulated MAW solutions and should be concluded by confirmation tests using fully active solutions.

3.4. Decontamination of liquid MAW streams by means of a new cationic exchanger

Proponent : CNEN , Casaccia

Proposal : 175-81-31 WASI

By using a new cationic exchanger, which belongs to the neo-alkylhydroxamic acids family, it is anticipated to reduce the content of the actinides and possibly fission products in various liquid MAW streams to extremely low levels.

The good extraction capability of this extractant with respect to plutonium and neptunium as well as to certain polyvalent cations allows a thorough decontamination of various MAW sources. Primarily two MAW streams will be studied :

- solvent wash alkaline waste;
- 2nd and 3rd U-Pu cycle waste solution.

Both radioactivity concentration and actinide separation will be investigated.

The extractant will be fixed on an inert support (extraction chromatography); other separation techniques will be investigated

too. Laboratory scale experiments with simulated and traced MAW will be carried out. Particular attention will be paid to the radiolytical and chemical stability of this new kind of organic ion exchanger.

3.5. Selective precipitation of actinides from various MAW streams

Proponent : KFK, Karlsruhe

Proposal : 177-81-31 WASD

This proposal aims firstly at separating the actinides from various MAW sources using chemical precipitation or flocculation technique and secondly at immobilizing the removed actinides into a long-term stable matrix (glass or ceramic).

The main actions of the work programme are :

- identification of the reagents capable of separating selectively the actinides and compatible with the matrix components (actinides decontamination factors greater than 100 will be aimed at);
- definition of the basic parameters (pH, temperature...);
- investigations on the main characteristics of the precipitates obtained.

In a first step, only simulated experiments on lab-scale will be carried out. Three types of MAW sources will be studied, i.e. MAW-concentrate, alpha-concentrate and residues from acid digestion process.

At the end of the programme confirmation tests with fully active solutions will be performed on laboratory and technical scale.

3.6. Decontamination of utility liquid wastes arising during PWR operation

Proponent : Sena, Chooz

Proposal : 181-81-31 WASF

This proposal intends to determine to what extent chemical precipitation can usefully replace evaporation techniques for the treatment of utility liquid wastes arising during PWR operation.

It is foreseen to install a prototype facility for the treatment of the utility liquid wastes by chemical precipitation on the site of the PWR Chooz. This facility will allow the definition of the main parameters acting on the overall DF's with respect to different real waste solutions. Optimum values will be established for industrial scale operation.

The programme consists of the following actions :

- design and construction of the installation;
- decontamination tests on standard solutions containing all or part of the various products generally present in solutions resulting from industrial operation;
- development to an adequate level of efficiency of the methods, processes and equipment;
- tests on solutions produced in the power station and production of flocculates of different concentrations.

3.7. Preparation of inorganic exchanger particles for the removal and immobilization of actinides and/or fission products from MAW solutions

Proponent : Agip Nucleare, Milan

Proposal : 231-81-31 WASI

The first objective of this proposal is the preparation of

inorganic exchanger particles (e.g. titanates, zirconates...) by means of a sol-gel process, capable of removing the actinides and/or fission products containing the MAW solutions. The second objective is to use, after a proper treatment, these loaded inorganic exchanger particles for long-term immobilization of the radio-isotopes of concern.

The following parameters will be investigated :

- choice of the best inorganic exchanger and the additives suitable for the subsequent sintering step;
- optimisation of the drop size during atomisation;
- optimisation of the temperature for calcination of sol-gel particles;
- determination of the distribution coefficients and the loading capacity of the exchanger;
- optimisation of sintering temperature and pressure and, possibly, study of the effects of additives to lower the melting point;
- determination of the mechanical properties of the product.

Experiments will be performed on laboratory scale, using radioactive trace elements.

Basic studies will aim to determine which MAW streams could be usefully decontaminated by such a process. However, some experiments will be carried out using simple simulations of alkaline solvent wash solutions.

3.8. Drum-dryer utilization for the treatment of MAW sludges

Proponent : KFA, Jülich

Proposal : 180-81-33 WASD

This proposal intends to adapt and optimize a drum drying device originally developed for HAW to the sludges resulting

from chemical treatment of MAW-concentrate.

The work programme consists of the following main actions :

- determination of the influence of process parameters acting on the product quality, using inactive simulated sludges as well as the off-gas composition ;
- vitrification of inactive simulated dry products;
- active runs to confirm inactive experiments with the drum-dryer;
- study of scaling-up of the process by means of lab-scale experiments;
- conceptual design of an industrial drum-dryer.

3.9. Denitration of MAW-concentrate

Proponent : KFA, Jülich

Proposal : 178-81-33 WASD

The objectives of this proposal are :

- determination of the operating conditions at which denitration process by means of HCHO or HCOOH is able to destroy quickly and safely the nitric acid excess containing the MAW-concentrate;
- examination to what extent denitrated, instead of neutralized MAW can be usefully treated, in a subsequent step, by chemical precipitation.

In a first step, the main parameters acting on the denitration performances will be investigated taking account of the disturbing effects of the elements or chemical compounds potentially present in the MAW-concentrate. These experiments will be performed batchwise using one litre of simulated MAW solution for each experiment.

The scaling up of the denitration process will be studied by means of a 20 litres denitrator loading capacity. Confirmation tests on real MAW-concentrate will be carried out at the end of the programme. Possibly, a continuous denitrator device will be designed and operated.

3.10. NOx removal by catalytic reduction

Proponent : CNEN, Casaccia

Proposal : 174-81-31 WASI

As the nitrates contained in the off-gas scrubber solutions contribute noticeably to the total nitrate content in the MAW-concentrate, this proposal aims at developing a method capable of reducing to N_2 the NO_x produced during fuel dissolution and denitration of various MAW streams.

The research aims at reducing NO_x gases into N_2 , either by means of NH_3 , using a synthetic zeolite catalyst, or by means of H_2 , using a Pt-AL catalyst.

The proposed research covers the following items :

- construction of a small lab-scale denitrator as a source of NO_x gases;
- design and construction of a lab-scale device for the catalytic reduction of the NO_x ;
- development of analytical methods for determining the chemical species acting on the process;
- study of all basic parameters (temperature, residence time, NO_x concentration...) influencing the process performances.

3.11. Electrical processes for the treatment of medium-active liquid wastes

Proponent : UKAEA, Harwell

Proposal : 176-81-31 WASUK

The aim of this proposal is to provide data on the application of a range of electrochemical processes to the treatment of medium active liquid waste. This treatment intends to concentrate the radioactivity of the actinides by means of electrochemical reactions so that no inactive salt is added.

The basic work programme is divided into three areas :

- Removal of particulates and colloids by electro-osmosis, electrofiltration and electrocoagulation. All of these processes produce a solid waste for disposal;
- Removal of dissolved ionic material by faradaic deposition as metallic elements or compounds;
- Removal of dissolved ionic material by adsorption onto high surface area electrodes and electrochemically controlled ion exchangers.

All these experiments will be carried out on lab-scale. At the end of the programme it should be possible to assess and compare the effectiveness of all these electrochemical methods in order to select the most promising ones for larger scale development. Studies of the MAW streams to which these processes can be applied will also be carried out.

4. PROCESSING OF WASTE CONTAMINATED BY ALPHA EMITTERS

4.1. Introduction

The largest volume fraction of wastes from reprocessing and mixed-oxide fuel fabrication consists of plutonium contaminated material (PCM).

Owing to the very long half-life of most plutonium isotopes (24 000 years in the case of Pu-239) and their radiotoxicity, the quantity of plutonium dispersed into the biosphere must be minimized. Final disposal of plutonium must satisfy high standards of isolation and long-term integrity.

As plutonium can be burnt in reactors, it is advisable to recover as much of it from the wastes as is practicable. For both options, namely disposal and recycling, it will be necessary

- to reduce the volume of wastes;
- to remove compounds which decompose by ageing or radiolysis;
- to develop fixation methods.

Under the first Community programme (1975-1979), a study was made of techniques for reducing the volume of the combustible waste, recovering the plutonium from combustible solid waste and conditioning the low-activity residues of such incineration processes. The development of treatment processes for this type of waste calls for an extensive experimental and engineering effort, and only one of the projects under the first programme, i.e. high temperature incineration, could be started early enough to reach the stage of pilot plant operation with low active waste. Two other projects, i.e. acid digestion and molten salt incineration, have been demonstrated under inactive conditions in 1980.

The plutonium recovery step of these processes was investigated in separate hot laboratory experiments.

A technological study of the pyrolysis process followed by controlled char oxydation established the general operating conditions.

The specific difficulties of recovering plutonium from incinerator ashes were analysed in a separate investigation, which identified those waste components and incinerator conditions, which are particularly adverse to leaching out the plutonium.

In the second programme, the development work on existing alpha-active facilities and those processes which are likely to lead to successful pilot plant operation before 1985 will be continued to that stage in order to gain experience and obtain design data for larger or improved units.

In a joint action of European laboratories the test methods for conditioned wastes and the relevant properties of conditioned waste products will be investigated. This action will be conducted together with the characterization activities for low and medium level (beta, gamma) waste and is described in Section 1.5.

Another important field for joint action is the development and comparison of techniques and equipment for measuring the alpha activity of treated and untreated wastes. Determination of the relatively low concentration of plutonium, unevenly distributed among various substances in the waste, calls for sensitive measurement and a complex interpretation method, and although most nuclear laboratories are equipped with alpha-measuring systems, there is not yet a standard technique for all types and package sizes of waste. The first step of this action will be the organization of a Round Robin Test, in which identical samples of waste packages will be measured in a number of European laboratories.

4.2. Operation of the FLK 60 slugging incinerator for various alpha waste streams

Proponent : SCK/CEN, Mol

Proposal : 190-81-42 WASB

The FLK 60 facility is presently operational for beta-gamma waste and will soon be tested with alpha waste material.

The continuous exploitation of the furnace, which is scheduled to start during the first trimester of 1981, will yield a number of important data necessary for a good understanding of the phenomena taking place during the combustion of different waste materials at various temperatures.

The off-gas purification will be studied by dry and wet method:

- in the wet way by cooling with direct injection of water, scrubbing, pre-filtration followed by absolute filtration;
- in the dry way by pre- and absolute filtration through metal bag filters of the off-gas cooled by addition of air.

In both cases, the granulometric spectrum and the radioactivity of the collected dust samples will be determined after each filtration step.

The material and heat balances will be calculated with variable feed composition and the treatment of the secondary waste streams will be developed.

The characterization of the basalt type granulate material will be performed and associated with the selection of the disposal techniques.

The recycling of the radioactive granules into the incinerator feed material in order to obtain a higher overall reduction factor will be tested and the addition of several materials intended to influence the melting point will be studied.

The obtained radioactive granulate will be ultimately processed either by casting homogeneously into a cylindrical mould or by producing blocks through hot pressing techniques.

4.3. Acid digestion

Proponent : KfK, Karlsruhe

Proposal : 187-81-45 WASD

4.3.1. Experimental facilities

Under the first programme KfK investigated and optimized the acid digestion process with the inactive test facility ILONA, which used a tray digester and a separate heating vessel. The principal disadvantage of the tray reactor concept is the deposition of residues on the tray and at the bottom of the heating vessel.

An alternative digester, the "ring reactor" developed by KfK, avoids deposits due to higher flow rates and velocities as well as a better dispersion of the residue. This innovation will be incorporated in the active pilot plant ALONA, which KfK intends to build and operate on the Eurochemic site in Mol under the second five-year programme.

The plant will consist of the following units :

- a cutting mill for grinding the waste to 2 mm ;
- the ring reactor (digester);
- the plutonium filter;
- the off-gas treatment system : a separator for sulphuric acid aerosols, three scrubbers and an acid recycling unit.

The plant will be installed in seven alpha-tight boxes. A further four glove boxes will be provided for the plutonium recovery process.

4.3.2. Programme of the active pilot plant ALONA

Beginning in 1982, the ALONA plant will process one tonne Eurochemic waste containing 6-10 kg of plutonium. During this campaign, the availability and reliability of the plant will be determined and any occurring faults investigated. The distribution of plutonium and americium during operation in the individual plant components will be measured and the conversion rate of plutonium oxide to plutonium sulphate will be determined.

Research to define the recovery process of plutonium from the residue will continue as a separate action.

4.3.3. Studies of the inactive ILONA facility

Further research on the off-gas treatment will focus on :

- the thermodynamics and kinetics of the system ;
- comparison of real characteristics with the calculated design data ;
- determination of peroxide consumption.

Other investigations will continue to optimize the acid recycling process in order to reduce the amount of nitric acid lost with the reject hydrochloric acid.

Finally, tests to destroy organic ion exchange resins by acid digestion are planned.

4.4. Molten salt incineration

Proponent : Agip Nucleare, Medicina Proposal : 191-81-44 WASI

In the period 1980-82 Agip Nucleare intends to carry on with the research and development of the process of alpha-waste incineration in molten salts. The process is based on controlled

combustion of the waste in a molten salt bath and on plutonium recovery by electrolysis.

Following an agreement with CEA, a coordinated working programme was established ; Agip Nucleare shall study the aspects relating to incineration in molten salts and CEA shall study the electrolytic plutonium recovery (see Section 4.5.).

The proposal of Agip Nucleare mainly concerns the operation of the pilot installation of Medicina (Bologna) and consists of the following points :

- a) Campaigns for incinerating non-radioactive or uranium contaminated waste in the pilot incinerator (1-2 kg/h). The main points to investigate are :
 - kinetics of the controlled combustion of waste;
 - efficiency of the off-gas absolute filtering system;
 - obtainable average volume and weight reduction factors of the waste;
 - mass balance of the material before and after the process;
 - safe operation of the installation and reliability of the regulation and control systems.
- b) Research and development concerning the materials suitable for containing the molten salts at the temperature and in the acid ambient of the ash dissolution phase.
- c) Completion of the pilot installation with the uranium electrolytic recovery section.
- d) Introduction of other improvements suggested by the operation of the pilot installation, especially regarding the following points :
 - continuous analysis of the exhaust gases;
 - measurement of the molten salt levels by means of automatic probes;

- scrubbing of the acid gases before off-gas filtering;
 - systems for transferring, filtering and intercepting the molten salt.
- e) Chemical and physical characterization of the final product of the process, consisting of ashes encapsulated in the solidified salt, which must be conditioned before final storage.
- f) Carrying on of the experiments regarding the incineration of plutonium contaminated waste in the benchscale equipment operating in Ispra.

4.5. Recovery of fissile material by molten salts electrolysis

Proponent : CEA, Fontenay

Proposal : 192-81-44 WASF

The development of an electrolytic process for recovering plutonium and uranium from the molten salt is carried out by the CEA in close collaboration with Agip Nucleare (see Section 4.4.).

The electrolysis technique will be an application of the methods already used for preparing dense UO_2 crystals from molten chlorides. The following process parameters will be studied :

- concentration of ions in solutions;
- dehydration level of the medium;
- electrode potential, etc.

It is also intended to study electrode reactions by potential measurements with a reference electrode, as well as some corrosion tests, to complete these investigations.

4.6. Combustion of PCM by pyrolysis

Proponent : UKAEA, Springfields Proposal : 186-81-44 WASUK

4.6.1. Objective

The initial pyrolysis of solid PCM (Plutonium Contaminated Material) can be accomplished either in the pure pyrolysis mode, or in the starved air mode. Work on the 250 g batch scale has established that there are significant differences between these two modes, the pyrolysis mode giving lower soot formation and smaller temperature spikes compared to the starved air mode. A more extensive study of these differences will be made, particularly related to the larger batches of a 10-20 kg/h plant. The work will entail a study of the compositions of the off-gases to determine the proportions of volatiles, tars and soot using techniques including gas chromatography and infra-red absorption methods.

4.6.2. Experimental approach

The kinetics of decomposition of solid PCM waste in either mode will be determined at a scale appropriate to a plant throughput of 10-20 kg/h. Packages of simulated waste up to 20 cm dia. weighing 2.5 kg will be pyrolysed in the 30 cm dia. incinerator to obtain rate data at temperatures up to 900°C. The temperature of the packages will be continuously monitored to assist in the interpretation of the data.

4.6.3. Application to liquids

In order, fully to understand how to pyrolyse all the most likely PCM waste arising a study will also be made of the pyrolysis characteristics of contaminated liquids. The major constituents of liquid PCM waste are tributyl phosphate and oils. The evaporation rates of these liquids at temperatures up to 900°C will be evaluated, together with the proportion of residual chars remaining after evaporation ceases.

4.6.4. Char oxidation

Conditions for oxidising the chars resulting from the initial stages of pyrolysis will be determined. Clearly the nature of the chars produced in the two pyrolysis modes will differ, as also will their amounts and physical forms. Chars from either pyrolysis mode, and obtained over the relevant temperature range up to 900°C will be oxidised in air to obtain weight loss weight loss versus time data. Information on the residual carbon contents of oxidised chars will be obtained to provide some data relevant to possible subsequent plutonium extraction processes. The char oxidation data must finally be combined with that from the pyrolysis work to determine the optimum feed rate of the 2.5 kg packages to an incinerator consistent with safe operation.

4.6.5. Design decisions and solutions

On completion of this work the following design decisions and solutions for a PCM waste incinerator could be made :

- Whether to use pure pyrolysis or starved air oxidation during the initial char formation stage.
- Whether to produce the char and subsequently oxidise it in the same or separate units and also whether to design for continuous or batch operation.
- The duty of an afterburner, designed to burn the volatiles from the initial pyrolysis, could be defined on the basis of the off-gas chemical analysis data.

4.7. Incinerator corrosion

Proponent : UKAEA, Harwell

Proposal : 189-81-44 WASUK

4.7.1. Objective

When the plutonium levels are sufficient to make recovery

desirable, the design of incinerators will have to ensure that temperatures are kept below ash sintering temperatures, plutonium is prevented from getting into the gas stream and entrapment of plutonium in the combustion chamber is avoided for criticality reasons. The monolithic tube concept for an incinerator has been shown to meet these requirements and corrosion resistances of candidate materials have been assessed at 900°C and 1000°C as part of a previous programme. Because of the corrosion problems monolithic tube incinerators are being designed for lower temperature operation (700-800°C) and to incinerate the waste in three stages (pyrolysis, ash oxidation, gas oxidation). The effect of corrosion on mechanical properties remains to be examined in the current programme.

The aim of this programme is to establish for design purposes the effects of corrosion, at 700°C and 800°C under pyrolysis and ash oxidation conditions, on the mechanical properties of three candidate alloys. No such knowledge presently exists but it is essential for designs using the more resistant alloys which also have a low ductility and therefore perhaps are particularly prone to further impairment of mechanical properties.

4.7.2. Programme

a) Corrosion rig, materials and specimens

Three corrosion rigs will be reconstructed, each able to hold six specimens of each of three alloys : Stellite 250, Stellite 6 and Nimonic 80A. Stellite 250 is included to compare the corrosion rate and morphology with corrosion of the same alloy used as a furnace tube in an incinerator at Windscale. Some coupons of Inconel 600 will be included for corrosion examination but not for mechanical testing since the alloy is ductile.

b) Exposure to the corrosive environment

The pyrolysis environment to which the candidate alloys will be exposed will be created by using waste consisting of a mixture of polythene, polyvinyl chloride and 3 types of rubbers which previous tests have proved to reproduce corrosion caused by typical combustible waste arising from the handling of nuclear fuel. The waste will be fed at a rate of one 5g capsule every 10 minutes during the working day under a flow of nitrogen. The capsules will be pyrolysed within the zone holding the 18 test specimens. During silent hours no capsules will be fed, but the nitrogen flow and temperature will be maintained. Corrosion temperatures will be 700°C and 800°C with a temperature cycle to 100°C over 20 minutes by withdrawing the samples from the furnace every working morning.

The ash oxidation environment will be created by immersing the test specimens in ash from the pyrolysis experiments and passing air through at an appropriate rate. The ash would be changed at intervals. Test temperatures will be 700°C and 800°C. Temperature cycling will be performed once per week. In the early stages of the programme exposure times of 20 days will be used. This may indicate the ability of grain boundary oxide and carbides to act as pre-existing "cracks". It is envisaged that 100 day tests may be necessary at 800°C and 200 day tests at 700°C.

The alloys will also be oxidised in air to provide a comparison with those exposed in the incinerator rigs.

c) Mechanical testing

Specimens after corrosion will be subjected to tensile tests to failure at high strain rates at the temperature of corrosion and at room temperature, and to impact tests on notched specimens at room temperature. Since there will be no welding of the tube, examination of welds is not included in the programme. The tube will be subjected to wear by the ram, but

a study of wear has not been included because, unless the tests closely follow the expected loading, velocity and frequency in the corrosive environment, they will be misleading. Such in situ tests are very costly. Some data may arise from the Windscale experience.

Metallographic examinations will be conducted to characterise fully the nature of attack and of mechanical failure.

4.8. Plutonium recovery from incinerator residues

Proponent : UKAEA, Harwell

Proposal : 185-81-43 WASUK

4.8.1. Objective

During the two year period 1978/79 the programme at Harwell has involved the following areas of work :

- (a) Construction and operation of an inactive incinerator capable of handling a wide range of combustible materials. This work has indicated the effect of varying incinerator conditions (e.g. throughput, temperature, gas composition) on the properties of the ash from different waste materials.
- (b) Extraction of plutonium from inactively prepared ashes that have been contaminated with different plutonium compounds. This work has indicated the effects on the efficiency of plutonium recovery from different leaching solvents, inorganic fillers present in the combustible wastes and the conditions of incineration of the wastes.
- (c) Construction and initial operation of an alpha-active incinerator (of similar design to that in (a) above) for the incineration or pyrolysis of a wide variety of combustible wastes contaminated with different plutonium compounds. Only preliminary leaching experiments on these ashes have been possible within the 1978-1979 programme.

The aim of the new programme (1980-82) is that by the end of the three-year period a detailed knowledge of the plutonium recoveries achievable from incineration and pyrolysis of a range of waste types will be available which could provide basic information for the optimum design of incinerators/pyrolysors for the recovery of plutonium from their residues. Additionally attempts will be made to assess the relative merits of incineration, pyrolysis, acid digestion and washing as plutonium recovery routes.

4.8.2. Work programme

The programme for the three-year period 1980-1982 will be based on the leach testing (for plutonium recovery) of model ashes made using the alpha-active incinerator constructed and commissioned during 1978-1979. Particular emphasis will be placed on the inter-relationship between the type of plutonium contaminant, type of waste material and the incineration/pyrolysis conditions.

Typical waste materials at present in use in the UK will be studied as well as possible new materials. Materials in use in other Community countries could be tested where they differ from those in use in the UK. Both individual waste materials and mixtures representative of plant waste will be studied. A range of plutonium contaminants (e.g. PuO_2 , $(\text{U}, \text{Pu})\text{O}_2$, $\text{Pu}(\text{NO}_3)_4$ solutions) will be examined and the oxides will have carefully characterised properties.

The incineration and pyrolysis conditions studied will be in the temperature range 400-900°C, using various gas atmospheres and residence times. The ashes and chars will be leach tested in order to correlate the leachability of the plutonium with the incineration/pyrolysis conditions. The effect of char oxidation under various conditions on the leachability of plutonium will be investigated.

In addition to comparing the plutonium recoveries by acid leaching achievable after incineration and pyrolysis, it is anticipated that a comparison may be made with other combustible waste treatment routes, i.e. washing and acid digestion. Selected contaminated wastes, as well as being incinerated and pyrolysed, will be subjected to a simple washing test, using for example 1 M HNO_3 to ascertain the relative plutonium recoveries achieved by the different treatment routes. If available, a small alpha-active acid digester will be used to compare the plutonium recovery obtained by acide digestion on the same selected plutonium contaminated material used in the incineration/pyrolysis and washing programmes.

4.9. Washing processes for fissile material recovery

Proponent : Alkem, Hanau

Proposal : 188-81-44 WASD

Most chemical reduction processes produce certain amounts of secondary waste. Direct decontamination of waste materials by washing techniques could present a simple and inexpensive way to recover plutonium and other fissile materials from solid contaminated materials.

In order to explore the possibilities of such methods, the following work programme has been proposed :

Studies for the selection of washing solutions

Based on the existing know-how it is foreseen to select solutions with high washing efficiency using uranium as contaminant. The performance of the most promising solutions will be tested with plutonium containing waste.

Design and construction of an inactive test unit

For the washing test conventional equipment will be constructed, e.g. ultrasonic baths, washing machines and leaching apparatus

installed with the appropriate ancillaries adapted for handling under plutonium active conditions.

Inactive process testing

The operation of the test rigs and the selected washing method will be examined with uranium contaminated waste materials on a technical scale. Where necessary, operating conditions will be improved by design modifications.

Construction of the active washing unit

The most suitable process selected from the inactive tests will be adapted for active service and operated under glove box conditions. This will require some modification for ventilation and services.

Active test runs

Active test runs with inorganic and organic waste will be performed. The plutonium content will be measured before and after washing to determine the efficiency of the process.

5. TESTING AND EVALUATION OF SOLIDIFIED HIGH ACTIVE WASTE FORMS

5.1. Introduction

The Community programme on the characterization of solidified HLW products aims at supporting and coordinating works going on in the various national laboratories with respect to the determination of the long-term chemical stability, primarily the rate of the glass/water or glass/salt solution reaction (the "leach rate"), since attack on the glass by water is the only likely way by which the radioisotopes that are contained therein could possibly start their journey back to man's environment. Another objective of the programme is to evaluate the various experimental methods and finally to provide a set of standard techniques in order to prove product specifications.

During the first Community programme (1975-1979), various European candidate matrix materials for HLW products were tested in a comparative study applying different tests methods. The laboratories involved were : AERE Harwell, Hahn-Meitner-Institut (HMI) Berlin and CEA Marcoule. The final report was issued under reference n° EUR 7138.

Eight reference substances have been tested under strictly identical conditions. The properties tested were :

- chemical durability,
- thermal stability and
- radiation stability.

The inactive and doped samples have been prepared by AERE, the active samples by CEA.

It was found that the rates at which glasses are attacked by water are strongly dependent on temperature and moderately on the pH level of the water. Leach rates obtained by different techniques lead to directly comparable results. Thermal treat-

ment generally induced only minor changes in the leach resistance. The temperatures giving rise to maximum effects were found to be not the same for the various materials. This is probably due to the difference in crystal growth and phases. For isotope specific leaching, it was observed that for ruthenium and cerium the released activities remained unchanged at higher temperatures. With respect to tests with various waters the leach rates for clay were found to be in all cases higher than those for granite or sea water.

In general, the residual glass phases were leached more readily than crystal phases. Rare earth phases crystallized in all products and noble metals were found to act as nucleation formers. Crystal growth starts around the phase boundaries of glass/noble metal.

The density changes of the plutonium doped samples suggest that they reached about half of the saturation. However, the samples show, so far, no signs of cracking and the stored energy values are insignificant.

The second programme is essentially a continuation of the first one. Its emphasis is directed towards the promotion of the understanding of basic leaching mechanisms and on the investigation of long term behaviour under both simulated repository and under radioactive conditions. The materials to be tested are basically the same as for the first programme and comprise glasses and glass ceramics. SCK/CEN (Mol), the University of Leiden and the Fraunhofer Institut will be joining the second test programme. SCK/CEN suggested to test the AVB and PAMELA glass compositions, envisaged to immobilize EUROCHEMIC waste. The new test programme is investigating :

- leach resistance,
- alpha radiation stability,
- thermal stability and
- mechanical stability.

The University of Leiden will carry out a limited test programme on the mineral constituents of the Synroc material.

An option to organise a Round Robin Test is being discussed with the aim to develop a standard method for quality control purposes.

A preliminary joint test programme for 1980-82 has been agreed. A contribution to the study of basic leaching mechanisms will include :

- analysis of the gel layer;
- analysis of the leachant;
- analysis of the chemical form of the dissolved plutonium for plutonium doped samples.

Simulation tests of repository conditions comprise leach tests in the presence of capping and backfill materials and in ground water according to the anticipated geological formation.

The radiation stability tests are essentially a continuation of the tests on alpha doped samples started during the first programme. This will be complemented by leach tests of heat treated plutonium doped samples.

Four of the active block samples tested during the first programme in Marcoule will be transferred to HMI for further testing and crystallographic examination.

In contrast to the first programme some tests are envisaged to investigate the mechanical properties.

5.2. Examination and evaluation of high activity solidified waste

Proponent : UKAEA, Harwell Proposal : 121-80-53 WASUK

The proposed programme, based on the achievements of the first programme, suggests to investigate :

a) leach resistance :

- some basic studies, both theoretical and experimental, of the leaching mechanism;
- studies of the leaching behaviour of various isotopes;
- the setting-up of leach tests simulating as closely as possible the conditions in a granite repository with, in particular, low water flow.

b) radiation stability :

- continuation of study of the existing $^{238}\text{-PuO}_2$ doped samples as the dose builds up;
- inclusion of crystallised versions of some of the glasses.

c) mechanical stability :

- study of the fragmentation of glass blocks under a realistic range of cooling schedules;
- study of the leaching of cracked glasses, e.g. the extent and effect of the penetration of leachant into cracks.

5.3. Characterization and comparison of HLW and products

Proponent : HMI, Berlin Proposal : 122-80-53 WASD

The work proposed comprises, in continuation to the first programme, an in-depth study of thermal effects on the leachability of fission product elements from waste products.

Tests under potential repository conditions comprise leaching with halite and carnallite brine and at temperature up to 200°C. This will include active block samples from Marcoule.

Heat treated plutonium doped samples will be leach tested and analysed. A test programme to determine mechanical properties is envisaged. Equipment for crack growth measurements (double torsion tests) and for the determination of surface defects (ball point test) is in construction.

5.4. Influence of various parameters on the leach rate of radioactive glass products

Proponent : CEA, Marcoule

Proposal : 123-80-55 WASF

Isotope specific leach tests with half-scale blocks containing 20 % of fission product oxides will be carried out under hot cell conditions to determine the effects of the type of water, temperature, pH, pressure and the mode of leaching on the leach rate. This includes long term tests of up to one year and tests in water equilibrated with granite. In parallel leach tests with inactive samples will be carried out in order to investigate the relationship between isotope specific leach rates and those derived by weight loss measurements. Devitrification effects will be tested with active samples.

5.5. Physicochemical characterisation of conditioned radioactive waste products

Proponent : SCK/CEN, Mol

Proposal : 124-80-55 WASB

Mol proposed an extensive test programme in agreement with the joint programme, examining the AVB and PAMELA glass compositions anticipated to immobilize EUROCHEMIC waste. This includes a contribution to the understanding of basic leaching mechanisms

and tests to investigate thermal and radiation stability.

Repository specific experiments to study the interaction of the conditioned waste with Boom clay will be performed. The appropriate container and backfill material will be taken into consideration. Some of the other European glasses will be included in the tests carried out under the conditions of a clay repository.

5.6. Testing and evaluation of potential ceramic materials for HLW immobilization

Proponent : Leiden University

Proposal : 125-80-53 WASN

The University of Leiden intends to test potential ceramic materials, like hollandite, perowskite and zirconolite. Research will be performed in particular on the following topics:

- synthesis of the host compounds for nuclear waste;
- crystallographic examination of thermal effect;
- leach tests under various conditions (temperature, pressure, % NaCl).

5.7. Determination of corrosion mechanisms of HLW glasses

Proponent : Fraunhofer Inst., Wuerzburg

Proposal : 232-81-53
WASD

Two borosilicate glasses of which one is the PAMELA composition will be examined. The programme is complementary to the HMI test programme. The target is to investigate corrosion mechanisms under simulated repository conditions (i.e. for salt) as a function of exposure time and temperature in the presence of water. Samples will be leached at a pressure of 130 bars and temperatures between 80 and 200°C in salt solution.

The concentration profiles of glass components and HLW oxides are determined in the leached glass samples. The gel-layer of the samples will be analysed in depth and its protective character will be investigated.

6. BURIAL OF LOW-ACTIVITY SOLID WASTE AT SHALLOW DEPTH

6.1. Introduction

Community activity on shallow land burial is a new project as the subject was not included in the scope of the first (1975-1979) programme. The activity proposed covers three different subjects which are related to the compilation and evaluation of data and current experience from existing burial sites, to the investigation of the efficiency of both artificial and natural barriers with respect to both radionuclide migration and safety aspects and to the study of advanced concepts of shallow land burial.

The submitted proposals do not cover evaluation and comparison of experience from existing burial sites. In order to implement this item of the programme, it has been agreed that a questionnaire be prepared and answered by the Working Party n° 6 of national experts. The evaluation of answers to this questionnaire, to be carried out by an independent expert under contract to the Commission, might also result in a more precise identification of future R & D projects. Work in this direction is in progress.

6.2. Influence of ground heterogeneity on the dispersion of radionuclides in the soil and soil water system

Proponent : Delft Soil Mechanics Laboratory Proposal : 193-81-6
WASN

The objective of this project is to evaluate the influence of soil heterogeneity on the potential spread of radionuclides and to develop and apply techniques to include this effect in the prognosis of the radionuclide mobility.

The work programme comprises the following stages :

- specification of the external parameters of the problem such as the source terms for migration species, the geometry of the migration field and the classification of both soil types and heterogeneity;
- review of the physics and chemistry of the migration of radionuclides in homogeneous soils and of the mathematical formulation of migration;
- analysis and evaluation of factors and phenomena that distinguish the heterogeneous problem from the homogeneous case and formulation of the mathematical problems associated with heterogeneity;
- development of techniques to cover heterogeneity and of models which take into account statistically distributed parameters and spatial variation of soil properties;
- comparison between results of homogeneous and heterogeneous models and advantages/disadvantages of the more advanced heterogeneous models.

6.3. Basic geochemical research for migration studies

Proponent : Risø National Laboratory Proposal : 194-81-6 WASDK

The aim of the research is to identify, study and characterize the dominating chemical reactions between radionuclides and components of top soil water phase in order to predict radionuclide migration.

The work programme is divided into the following three sub-projects which supplement each other :

- Complex formation of selected radionuclides with carbonate and other ligands found in ground water. This subproject includes investigations on possible complex formation of strontium, cobalt and a rare earth element with the carbonate,

bicarbonate system and with two amino acids commonly found in top soil.

- Radionuclide-soil organic matter interactions. This subproject is aimed at establishing the stability of selected humic acid complexes of interest to shallow land burial and to elucidating, by a dynamic method, the possible influence of soil organic matter on the migration behaviour of radionuclides.
- Chemical speciation of selected radionuclides. Within this subproject stability diagrams will be constructed for strontium, cobalt, technetium and a rare earth element on the basis of literature data as well as of results of the two subprojects outlined above. Possible chemical species dominating under given (pH - Eh) conditions will be identified and importance of complex formation in connection to radionuclide migration will be discussed.

6.4. Development of waste unit for use in shallow land burial

Proponent : Risø National Laboratory Proposal : 195-81-6 WASDK

The purpose of the project is to develop an advanced burial system where standardized waste units of hexagonal shape are placed systematically in such a way, that the narrow crevices between the units can be filled with a sealing material such as cement or bitumen. In the resulting monolithic agglomeration of waste units the risk of contact between waste and water will be greatly diminished. In addition outer barriers against water percolation and against accidental intrusion from above will be provided.

The standardized waste units consist of an inner standard 200 l steel drum surrounded with a layer of concrete, which gives the hexagonal form and provides additional strength and corrosion protection to the drum. The concrete is supposed to

be cast around the drum after it has been filled, so that a monolithic cast is produced without cracks along the otherwise necessary lid. The resistance of the units against temperature cycling and corrosion, which is expected to be good even in long term interim storage in moist atmosphere, will be checked.

An extremely strong and dense concrete, which should be excellent for the purpose, has been developed in Denmark at the Alborg Portland Cement factories. Investigation of some properties of this concrete is part of the project. Moreover, various conceptual designs of waste units, handling and burial systems, as well as inactive testing of full scale units are foreseen.

6.5. Improvement of the quality of the radioactivity confinement by soil barriers

Proponent : CEA, Fontenay

Proposal : 196-81-6 WASF

The aim of the project is to devise methods of selecting and implementing processes for improving the radioactivity confinement properties of the barrier provided by the soil in the case of shallow land burial. The various methods and processes to be analysed act mainly on the two following parameters :

- the diffusion parameter, through a reduction in permeability;
- the retention parameter, through the introduction of colloidal substances into the soils.

The work programme comprises the following stages :

- compilation of an exhaustive catalogue of methods and industrial processes for rendering soils impermeable;
- classification of the above-mentioned processes according to the operating principle, the geological quality of the

environment to which they are applied, and to their cost effectiveness;

- experimental laboratory studies on the in situ improvement of the retention properties of soils;
- full-scale experimental studies on test plugs in order to test the retention capacity of a filler that could possibly be placed between the stored waste and the receiving soil.

6.6. Assessment of radiological protection aspects of shallow land burial of low level waste

Proponent : NRPB, Harwell

Proposal : 233-81-6 WASUK

The objective of this project is to carry out a generic assessment of the radiological protection aspects of shallow land burial, placing particular emphasis on the period after the site has been closed and no further disposal of waste takes place. The assessment includes an analysis of the sensitivity of the results to variations in the assumptions made and the values of parameters used.

The results of the study will be used to draw general conclusions about site selection, operating and closure procedures and the period for which access to closed sites should be restricted. In addition they will be used in a re-appraisal of the types and quantities of waste for which shallow land burial is an acceptable disposal option.

7. STORAGE AND DISPOSAL IN GEOLOGICAL FORMATIONS

7.1. Introduction

The objective of this action is to investigate the possibilities of isolating radioactive waste into appropriate geological formations in such a way that public health and safety will not be endangered during the period of time required for their natural radioactive decay to an innocuous level.

Generally, all the results obtained up to now, in the framework of the first Community programme (1975-1979), seem to confirm the realism and the merits of options originally chosen.

In particular, it has been shown that following the inventory of geological formation in the Community potentially suitable for the disposal of radioactive waste, a wide range of choices are available to the authorities responsible for prospection and subsequent study of possible disposal sites.

It can already be affirmed that it is possible to realise disposal facilities within the present state-of-the-art, whatever geological formations are involved (salt, clay, granite), but provided a certain number of conditions are met, and the programme has done a lot towards clarifying these conditions. However, there is no evidence at this stage to support the view that one type of formation is more suitable than another for a radioactive waste repository. At the most, it could prove to be the case that each type of formation has particular merits with regard to different categories of waste.

The second five-year programme is the logical continuation of the previous one and relies on the preliminary results de-

rived from it; in particular, the distribution of tasks remains largely unchanged. Accordingly, clay formations are studied mainly by Belgium and Italy, crystalline rock by France and the United Kingdom and salt domes by Germany and the Netherlands. Back-up studies relevant to all these types of formations are being carried out by Denmark. Greece, Ireland and Luxembourg are at present not directly involved in the research. It may be noted, however, that these options in no way involve any final commitment to the type of formation being studied, apart from in Germany.

However, the second programme, differing from the first one, emphasises certain projects considered as priorities, i.e. :

- exploitation of deep reconnaissance drilling campaigns;
- design and exploitation of underground experimental rooms and shafts;
- research on artificial barriers (containers, geo-chemical barriers), backfilling and sealing materials;
- characterisation of mechanical, hydraulic and thermal behaviour of the rock matrix;
- characterisation of hydrogeological conditions and the migration of radionuclides in the geosphere;
- risk analysis linked to waste disposal.

Waste disposal into the sea-bed has also been taken into consideration as a possible long-term alternative to disposal in continental geological formations. The programme will devote some effort to a study of the general principles underlying this concept and to an assessment of the feasibility of disposal in geological structures under selected ocean areas as a variant of disposal in geological formations on land.

Finally, a project has been started up with a view to improving the methodologies used to estimate the potential of disposal in geological formations. It concerns basic studies

of general interest (such as the development and application of analytical methods for the classification of geological formations suitable for disposal purposes) and studies for implementing new reconnaissance methods and ways of characterising the sites.

The research areas have been classified according to an operational logic which differs slightly from a purely scientific one. The research proposals which have, up to now, been retained, have consequently been regrouped according to the projects indicated in Table 7.1.

I. STORAGE AND DISPOSAL IN CONTINENTAL GEOLOGICAL FORMATIONS

1. Site selection and general characterisation
2. Deep drilling programmes and borehole studies
3. Underground experimental rooms and shafts
4. Artificial barriers
 - Waste canisters
 - Geochemical barriers, backfilling and sealing
5. Internal equilibria of formations before and after disposal
 - Characterisation of formations
 - Radionuclide migration phenomena
6. Mathematical modelling
7. Safety analyses
8. Pilot scale repositories
9. Development construction and exploitation techniques
10. Repository design

II. DISPOSAL INTO THE SEA-BED

III. IMPROVEMENT OF METHODS FOR ASSESSING THE POTENTIAL OF GEOLOGICAL DISPOSAL

- Basic studies of general interest
- Development of characterisation methods

TABLE 7.1. OPERATIONAL CLASSIFICATION OF RESEARCH AREAS CONCERNING THE STORAGE AND DISPOSAL IN GEOLOGICAL FORMATIONS

7.2. Exploitation of deep drilling campaigns

Objective :

Identification of structural, mechanical, hydraulical and geochemical characteristics of selected host rock.

7.2.1. Drilling campaign around the Mol site for hydro-geological research

Proponent : CEN/SCK, Mol

Proposal : 144-80-7 WASB(1)

This programme item aims at the installation of hydrological observation wells at 16 locations in an area around the Mol site. The drilling campaign and well observations have to supply the data and information necessary for the modelling of groundwater movement in the aquifers above and immediately beneath the boom clay. They have to enable :

- identification of the different individual aquifers in the area;
- water and rock sampling, borehole logging;
- installation of piezometric wells in the different aquifers;
- periodic measurement of the piezometric level.

The drilling campaign is preceded by a survey and search of existent hydrological data for the area, a siting and permit study, a design of the wells and their specifications.

In order to get hydraulic parameters a pumping test is planned in a second phase.

7.2.2. Geological assessment of crystalline rock formations

Proponent : NERC/IGS, Harwell

Proposal : 128-80-7 WASUK (1)

At the Altnabreac (Caithness) site, drilling is complete and the following studies will be continued or initiated :

- hydrogeological testing of hydraulic properties in the boreholes using the available packer system, to determine groundwater flow behaviour in the upper 300 m of the rock;
- hydrogeological studies of deep and shallow groundwaters using pumped abstractors from isolated borehole zones to determine the natural chemistry of crystalline rock groundwater;
- assessment of the relative value of the wide range of borehole geophysical logging techniques which have been run in the boreholes, with a view to defining the best operation modes for the useful logs and assessing the potential for using these drilling 100 % cored boreholes;
- examination, from the rock cores, of the zone of highly altered granite material and fissures to assess, their physico-chemical properties and potential role in localised radionuclide retardation.

Field investigations will also be started up at other identified sites. At each site the following programme will be carried out :

- surface geological, geophysical and hydrological surveys to enable the boreholes to be sited to maximise the scientific return and also to enable the detailed data derived from the borehole studies to be assessed on a real basis;
- drilling to verify the structure of the rock formations to provide rock cores for detailed laboratory analysis and to provide boreholes in which detailed geophysical, hydrogeological and geochemical investigations can take place.

7.2.3. Deep drilling investigation in granite formations

Proponent : CEA, Fontenay

Proposal : 127-80-7 WASF

The programme aims at characterising granite formations in selected areas in France. Deep drillings have already been performed on one site during the previous programme. It is now foreseen to drill several deep wells on two other sites (one at 1000 m depth, one at 1500 m and several drillings for a cumulated depth of 2500 m).

The location of the second granite formation will be determined after geological and geophysical studies on the area have been carried out. Depending on the subsurface geology, two or three wells will be drilled. The parts of the work are :

- well studies (geophysical celllogging hydraulic tests, core orientation measurements, borehole televiewer);
- studies on samples (fracture, tectonics, relative displacements, chemical and mineralogical weathering, physical characteristics, waste analysis);
- determination of a hydraulic model taking into account thermal, hydraulic and mechanical conditions as well as the interaction and diffusion of radionuclides.

The objectives of well drillings in a third granitic formation remaining identical, the programme will be improved by preceding results.

An exploratory well to a depth of 1500 m will be drilled in order to characterise the underlayers of a possible repository.

A detailed exploratory method will finally be developed to determine the properties of the lateral extension of the formation.

7.3. Design and exploitation of underground experimental rooms and shafts

Objectives :

- to define the characteristics of the environment (experimental programme)
- to assess the impact of the repository on the geosphere (measurements of local effects of the excavation and of thermal release on the state of stress and on the hydraulic and thermal conditions at depth; modeling).

7.3.1. Use of an underground cavity as test facility for radioactive waste disposal in clays

Proponent : CNEN , Casaccia Proposal : 140-80-7 WASI

Sub-proponent : ISMES, Bergamo

The exploitation of a deep underground laboratory as a test facility represents the best way to fully evaluate and investigate geotechnical, mechanical and thermomechanical problems concerned with the radioactive waste disposal in clays. The Italian approach to realize the underground laboratory is based mainly on the adaptation of an already existing cavity or, as an alternative, on the drilling of one horizontal gallery at the base of a high front in a clay pit.

The survey of the possible favourable situations has started and the final decision is planned for the end of 1981. The underground laboratory, which will be designed and constructed as a multi-purpose test facility, will be used in the first phase to investigate the thermal behaviour of clays and to measure the convergence of deep holes drilled in clay formation.

7.3.2. Underground experimental room beneath the Mol site

Proponent : CEN/SCK, Mol

Proposal : 129-80-7 WASB

Study and construction of an experimental facility in the plastic clay at a depth of 220 metres.

The construction works started at the end of 1979 by the digging of a shaft of 2.65 m useful diameter which will give access to a 6.5 m high crossing chamber with a useful diameter of 6 m. Both shaft and crossing chamber are dug by the ground freezing method. The shaft is lined by two concentric un-armoured concrete walls, separated by a polyethylene sheet insuring water tightness. The crossing chamber is lined with a 1.2 m thick armoured, monolithic concrete wall. The experimental gallery will be 25 m long and lined with ribbed and bolted cast iron segments. The gallery will be dug by the freezing techniques.

Experimental programme

Advantage will be taken of the digging of the shaft to implant at the top of the clay formation a series of cells and gauges in order to measure the total in situ earth pressure, the piezometric pressure, the temperature in each measuring point and the convergence of the shaft lining. Extensometric and inclinometric measuring devices will be embodied in the clay in the same direction and above the future gallery in order to measure the deformation of the clay body during digging and after thawing. After completion of the gallery, numerous experiments will be started up in the near clay field surrounding the gallery :

- lining resistance experiments (stresses, strains, convergence);
- geo-mechanical tests on the clay (creeping, measurement of the pressure field,...);
- heat transfer experiment;
- corrosion phenomena of metal samples and lining segments in contact with clay at actual pressure;

- radionuclide diffusion experiments from the gallery in the near clay body.

7.3.3. Planning of a pilot test cavern in granite

Proponent : CEA, Fontenay

Proposal : 139-80-7 WASF

The realisation of an underground testing facility in a crystalline formation is aimed at the performance of in-situ tests and experiments which are needed to complete theoretical and laboratory studies in process of development.

The first stage deals with site selection and conceptual design of the cavern. The main phases are :

- reconnaissance of previously selected sites and synthesis of the data selection of the most suitable site;
- programme of in-situ tests and experiments. These are related to heat transfer, rock-mechanics, hydrogeology, technologies for storage or disposal and retrievability;
- complete design of the facility.

The second stage (construction and equipment works as well as in-situ tests and experiments) will be performed later on.

7.3.4. Thermophysical in situ investigation on HAW disposal in rock salt (Asse)

Proponent : GSF, Clausthal

Proposal : 130-80-7 WASD (1.1.)

The evaluation of water liberation into HAW-boreholes as a function of temperature, stress state, rock permeability and mineralogical composition is the main objective of the in-situ experiments which are being presently performed (Temperature Test 4) or which are planned for the near future (Temperature Tests 5,6) in the Asse salt mine.

Temperature Test 4 is outlined to produce the maximum possible amount of released water, using a constant power input of 9 KW by a 5 m long heater placed in a 15 m deep vertical borehole. The water release is measured as a function of time and temperature.

Temperature Test 5 is planned to be operated with additional measurements of rock permeability before, during and after heating in order to evaluate the relationship of water release mechanisms and the rock stress state. These measurements are completed by monitoring seismoacoustic signals and rock deformations.

In order to determine the in-situ temperature dependent water release, a stepwise increase of the maximum rock temperature is planned. Each temperature step will be held constant for approximately three months. The tests are accompanied by a careful investigation of the mineralogical composition of the salt formation before and after heating, because the release of crystalline water results in a change of this composition.

In Temperature Test 6 the hexagonal arrangement of seven HAW-boreholes shall be simulated. The main objective of this experiment is to investigate the mechanical response of the rock mass to a high heat input (70 kW). Seismic and micro-seismic monitoring is planned parallel to the determination of heat induced stress fields.

The water release will be monitored in the central borehole under the influence of overlapping temperature fields which results in higher temperatures but smaller temperature gradients (compared with single boreholes).

7.3.5. Release of water and gas components in salt (Asse)

Proponent: GSF, Clausthal

Proposal : 130-80-7 WASD (1.2.)

The rock-salt, in which high-level radioactive waste will be disposed, contains small amounts of water and ga. components

such as CO₂, H₂S and gaseous hydrocarbons. Some other components like Cl₂ and HCl will be generated by temperature and gamma irradiation. All these components will interact with the containment and the solidified waste. In order to calculate how much of these components will be set free into the waste containing borehole, a mathematical model for generation and migration must be developed in laboratory and in-situ tests.

The following parameters will be determined :

- water content of rock-salt coming from different salt mines;
- liberation of the various water components;
- gas components in the rock-salt;
- generation of gaseous products by cracking minor and trace minerals as a result of temperature and radiolysis;
- porosity and permeability within the rock-salt;
- diffusivity of the liberated water and gas components.

7.3.6. Investigation on the processes during flooding of a HLW salt dome repository with water and brine

Proponent : GSF, Clausthal

Proposal : 130-80-7 WASD(1.3a)

The processes in a flooded mine will be investigated. Therefore the differential equations, with their different conditions and stability criteria for diffusion, migration and viscous flow in galleries and shafts are to be developed. Laboratory and in-situ experiments at the Asse and other mines will be made.

In 16 already flooded mines the conditions (temperature, concentration profiles and the viscous flow) of the brine within the shaft are measured. To determine the migration across zones of different brine compositions, the spreading of some tracers will be measured.

These phenomena in flooded mines will be further investigated in glass models in the laboratory. In these models it is easy

to change the conditions such as temperature, temperature gradients and geometry. In order to compare the results with the results from a flooded mine, it is necessary to develop dimensionless parameters and differential equations for migration and viscous flow.

Some small shafts or galleries in the Asse salt mine will be flooded with brine and the migration and flow at distinguished conditions will be investigated.

With the results of these laboratory and in-situ experiments, methods for sealing boreholes, galleries and repositories will be developed.

7.3.7. Measurements of deformation of galleries in the Asse salt mine

Proponent : GSF, Clausthal

Proposal : 130-80-7 WASD (1.4)

Accompanying the in-situ heating experiments in the Asse mine, the deformations of the surrounding rock masses will be monitored. These measurements will be carried out in underground rooms, at pillars and in the surroundings of heater boreholes.

The results will provide data necessary for the assessment of the mechanical stability of the salt rock before, during and after heating.

As the creep deformation rate strongly depends on temperature and stress, it has to be guaranteed that inadmissible convergence of the galleries does not occur during the operating period of the repository.

7.3.8. Absolute stress measurement in salt (Asse)

Proponent : GSF, Clausthal

Proposal : 130-80-7 WASD (1.5)

The measurement of stress within a rock mass is essential for studying the primary stress conditions and their change due to heating experiments. Although a large number of stress measuring devices have been introduced in the meantime, few of these have reached popular usage and not many instruments measure stress directly.

Two basic techniques are used : those in which stress is calculated from deformation and those in which a component of normal stress is substituted by hydraulic pressure. In the first technique, stress determination based on deformation may produce erratic stress values since rock-salt is not an elastic medium. In the second technique, deformation of the rock in different directions is measured by borehole deformeters. To convert these measurements of deformation to stress, it is necessary to know the stress-strain relationship for the host rock.

Other techniques such as hydraulic fracturing or hydraulic Flat Jacks also have to be explored for use in salt.

The objective of the study is to compare the application of these methods and improve their accuracy.

7.3.9. Laboratory investigation of rheological salt rock properties under various conditions including elevated temperatures and radiation

Proponent : GSF, Clausthal

Proposal : 130-80-7 WASD (1.6)

This laboratory programme, in which the salt rock properties under general conditions of stress and temperature will be

investigated and identified, will support ongoing efforts to evaluate the corresponding material behaviour and parameters, formulate a suitable material model for structural design calculations and predict the response of rock-salt to the perturbation of a radioactive waste repository.

Continuing the experimental studies of the first (1975-1979) Community programme, the future laboratory experiments addressing the effects of temperature, stress, time and radiation will develop more detailed and extended knowledge of the mechanical properties and their alterations of this host rock under these conditions. To achieve this goal, a series of uniaxial and triaxial short- and long-term tests will be carried out with salt samples under varying conditions, using specially designed testing apparatus.

The results of the individual experiments shall provide and verify the fundamental mechanical short- and long-term material properties of the salt. Furthermore, the resulting material data shall support the development of an appropriate constitutive material model for the temperature dependent mechanical response of rock-salt and its application in computer calculations addressing adequate thermomechanical and structural design of a subsurface repository.

7.3.10. Geophysical monitoring of the environment of underground test fields in the Asse salt mine

Proponent : GSF, Clausthal Proposal : 130-80-7 WASD (1.7)

Some of the thermo-mechanical effects resulting from HLW disposal in salt rock can be studied by seismic methods, which can supply information from the interior of the rocks without damage or other disturbing reactions. In the framework of the underground heating experiments in the Asse salt mine, an array of geophones will be arranged to detect and localize

possible fractures. As a first step, the rate of events before heating will be determined.

For the investigation of variations of rock properties (elastic coefficients, joint porosity) the propagation times and amplitudes of elastic impulses created by the "Hammer-blow" method will be measured.

The results are also necessary input parameters for subsequent numerical calculations of the stability.

7.3.11. Mineralogical investigation of thermometamorphic processes in salt

Proponent : GSF, Clausthal Proposal : 130-80-7 WASD (1.9)

The heating of salt leads to a thermometamorphic solutioning of mineral components in dependence on their thermic stability, and to transport and recrystallization in cooler regions or in the same place after the termination of heat dissipation.

These processes are generally known, but have hardly been investigated in salt in a detailed form as yet. They have to be controlled by phase analysis and the results obtained from samples from temperature test fields are to be compared to those from natural, thermally changed areas (basalt contacts, etc.). The particular significance of these investigations lies in the possibility of becoming familiar with the effects of extended heating periods.

The study will include :

- special sampling of the temperature test fields and preparation of the specimens for investigation;
- microscopic analysis of the thin sections and ensuing phase analytical and geochemical investigations of the reaction products;

- sampling of natural temperature contacts in salt in the surroundings of magmatic intrusive rocks (basalt, lamprophyres, dikes);
- treatment and investigation of these samples as indicated in the preceding points;
- evaluations and comparison of the results, with special regard to the differing length of time and intensity of heat load of the salt.

7.3.12. In situ experiments in the Asse salt mine on the stability of borehole casings as well as development and testing of a standard device for convergence measurement

Proponent : GSF, Clausthal Proposal : 130-80-7 WASD (2.3.)

The programme performed in the past will be continued. The objectives of the planned activities are the testing of device developed for in-situ measurements and the measuring of basic data relevant to convergence of boreholes and stresses in the rock salt.

The parts of the programme are :

- installation and running of the "Simulation test" at the 775 m level of the Asse;
- measuring of the drift of different types of strain gauges;
- testing and hand over of the Standard Device for Convergence Measuring;
- analysis and documentation of the data obtained in the experiments.

7.3.13. Convergence and pressure measurements in dry-drilled boreholes in rock salt (Asse mine)

Proponent : ECN, Petten

Proposal : 142-80-7 WASN
(1 and 2)

The detailed convergence measurements in the dry-drilled 300 m borehole in the Asse mine started under the previous programme, will continue. The measuring device will be modified and adapted to a somewhat higher measuring range (282-342 mm). The device consists of a marking system, a measuring clock, a compass and an optical system. By periodical examinations the changes in diameter and possible alterations of the surface images can be obtained and stored on video tape.

The results of the convergence measurements directly give information about the accessibility of the borehole as a function of time. By using this convergence behaviour, it is possible to calculate a creep law fitting the measured curve. During this study, several parameters are varied to establish the influence of each parameter. Calculations for verification of the measured data will be performed with the ECN available computer codes (Marc, Golia).

Measurements of convergence and pressure in heated areas in the dry-drilled 300 m deep borehole will be carried out in two types of experiments :

- In external overpressure experiments, a heated probe will be placed near the bottom of the hole. The pressure build-up on the probe and the wall temperatures will be measured as a function of time and axial direction.
- In free convergence experiments, a heated probe will be placed at several levels in the hole. The decrease of the diameter of the hole and temperatures will be measured both as a function of time and axial direction.

7.3.14. Laboratory and in-situ measurements of cataclastic effects in rock salt

Proponent : ECN, Petten Proposal : 142-80-7 WASN (3)

Sub-proponent : Delft Technical University

It is a general problem in mining to understand the mechanism of convergence of underground tunnel walls and to get a clear insight into the stress patterns in the surrounding rock of underground cavities. At great depths fracturing (cataclasis) will always occur in the wall rock. Cataclasis causes volume increase. Volume increase causes convergence. In addition the fracturing means that the stability of the walls is at stake.

The Technical University of Delft has developed a theory on fracturing of underground tunnel walls and on the stability of the fracture area. However, for rock salt the specific parameters still have to be determined. This touches on laboratory conditions as well as on in-situ conditions.

A measuring device applying acoustic methods will be developed to detect fractures at a distance of 0-2 m and later on up to 10 m from the tunnel wall. Velocities and differences in velocities of elastic waves through the materials will be measured.

The measuring equipment will be tested in the Asse II salt mine. The acoustic pulse emitters and the receivers will be placed in boreholes with a depth of about 2 m. In order to interpret the measured data, the relation between acoustic phenomena and material characteristics (structure, condition, stress, etc.) will be determined in the laboratory.

7.4. Artificial barriers - geochemical barriers, backfilling and sealing

Objectives :

- selection of materials suitable for geochemical barriers to migration of radionuclides; influence of temperature and irradiation; interaction with the geological environment and the conditioned waste;
- selection of materials for the backfilling of boreholes and galleries and sealing of the shafts; interaction with the geological environment; characterization of the permeability at the cavity wall; physico-chemical stability; long-term stability.

7.4.1. Review of backfilling and sealing studies and techniques

Proponent : Mott, Hay and Anderson, Croydon Proposal : 204-81-
WASUK

A comprehensive review and assessment will be undertaken into the functional requirements, materials, placement and demonstration facilities needed in connection with the backfilling and sealing of medium and high level waste repositories in different host ground types (salt, clay, granite).

Experience to date has shown the importance of integrating the technical objectives and specific scientific research knowledge, with the practical engineering implementation of these requirements, based upon existing experience and technology.

The first phase is primarily a fact-finding stage; it comprises review of backfilling and sealing techniques appropriate to potential host grounds.

The second phase aims at :

- assessing the potential application to crystalline rock, weak rock (clay type) and evaporite hosts, of the findings

identified in the first phase;

- identifying features of the backfilling and sealing procedures requiring validation, development and research, in relation to host type;
- identifying property and performance measurements required, and analytical procedures necessary, for design and assessment;
- considering and making recommendations for the design of validation or feasibility experiments, related to backfilling and sealing a repository.

7.4.2. Selection and testing of materials and techniques for backfilling and sealing of boreholes and galleries in clay. Experiments on plugging of freezing boreholes at Mol

Proponent : CEN/SCK, Mol

Proposal : 144-80-7 WASB (2)

Identification, selection and testing of potential sealing materials

Research will be performed on an ideal mixture including clay, bentonite, cement, additives, water on the basis of the following characteristics :

- pumpability;
- permeability and porosity;
- consistency indexes;
- shrinkage;
- mechanical characteristics (compression, tensile and shear strengths);
- ion exchange capacities;
- leachability;
- chemical and physical compatibility with in situ clay and gallery linings.



Laboratory and in situ tests

In the laboratory, the interface between the clay samples and the backfilling mixture will be plugged and studied for permeability, diffusion, fissuration, settlement, shear strength, etc.

In situ tests will be carried out on the horizontal freezing boreholes surrounding the experimental gallery and filled by different potential mixtures. The possibility of direct plugging or remote measurements from the gallery is being studied in co-operation with CNEN (see Section 7.4.3.).

7.4.3. Studies and research relating to borehole plugging in clay

Proponent : CNEN, Casaccia Proposal : 199-81-7 WASI

Sub-proponent : ISMES, Bergamo

This proposal aims at evaluating and developing the instrumentation as well as the procedure of testing in situ the effectiveness of sealing the boreholes containing the wastes by means of appropriate mixtures of clays and additives. The main phases of the programme, co-ordinated with the analogous one carried out at CEN/SCK in Mol (see Section 7.4.2.), are :

- assessment of the critical parameters that can be measured in situ to check the effectiveness of the proposed sealing mixture on the basis of the available techniques;
- design and construction of the instrumentation and testing of the experimental procedure by means of preliminary laboratory runs on models;
- utilisation of the instrumentation to test the effectiveness of borehole sealing in situ at the Mol site.

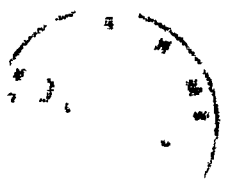

7.4.4. Study on backfill materials, backfilling and sealing techniques in granite

Proponent : CEA, Fontenay

Proposal : 202-81-7 WASF

After the various basic studies made by the CEA on the adsorption properties of selected backfills, problems raised by the choice and method of setting up the backfill materials in a waste repository have to be defined.

Studies will concentrate on clay material, aggregates and other material. Permeability measurements of different mixtures will be undertaken as well as the estimate of dispersivity and retention properties of the backfill.

7.4.5. Physico-chemical stability of geo-chemical barriers

Proponent : CEA, Grenoble

Proposal : 205-81-7 WASF

The study investigates the physical and chemical stabilities of the artificial barriers (clay composites) as well as the natural ones (crystalline rock) used in a high level waste geological repository. The experiments will be performed in representative conditions of the disposal.

Dissolution kinetics of the minerals in crystalline water will be followed by water analysis. The changes in material properties during the treatment by crystalline water will be measured by the usual methods of examination for divided solids. Special attention will be paid to new methods : scanning electron microscopy and electron spectroscopy for chemical analysis (ESCA).

Corrosion experiments of the geochemical barrier will be made in the laboratory at normal pressure and temperature up to 100°C, and in a pressurized loop up to 100 bars and 310°C. Carbon dioxide partial pressure effect on corrosion mechanisms

of the minerals will be examined.

The selected materials are three clay components (attapulgite, illite, montmorillonite) on the one hand, and on the other, the granite considered as representative for the site of the future repository.

7.4.6. Study on physico-chemical factors related to the retention power of artificial barriers in granite

Proponent : CEA, Fontenay Proposal : 203-81-7 WASF (4-11)

The study will provide information on the retention capacity of the clay materials that are potential constituents of an artificial barrier. The following topics will be dealt with :

- behaviour and radionuclide retention in reducing medium; study and determination of mobile forms of plutonium and americium;
- optimization of selected barriers; influence of water characteristics;
- influence of physical conditions in the geochemical barriers (temperature, pressure, irradiation respectively up to 300°C, 90 bars and 10^9 rads);
- retention of anionic elements (Tc and I);
- study of radionuclide diffusion through the bentonite;
- characterisation of a selected geochemical barrier (chemical, mechanical, thermal and hydrodynamical characteristics);
- influence of constraints linked to the storage environment on the geochemical barriers and crystalline rocks (influence of CO₂ pressure and sulphide ions);
- retention study with real granitic waters.

7.4.7. Studies on cavity wall lining, backfilling and sealing

Proponent : UKAEA, Harwell

Proposal : 253-81-7 WASUK

Laboratory and desk studies of potential lining, backfilling and sealing materials

Preliminary studies already carried out indicate that potentially useful materials include crushed rock, bentonite, concrete and asphalt. Laboratory studies of the interactions of the first two of these and some waste nuclides, commenced under the previous contract, will be continued and extended to include other fission products and actinides of interest. Interactions of these nuclides with concrete and asphalt will also be studied. This work will be carried out in parallel with studies on nuclide migration (see Section 7.6.5.).

Laboratory studies of materials under repository conditions will be carried out, including swelling of bentonite and behaviour of concrete made with various aggregates.

Field studies at the Cornwall test site will be included if the site proves suitable.

The results of a desk study to consider the potential uses of concrete in a repository carried out under the previous contract, will be used to define an experimental programme to provide data not otherwise available. This is likely to include volume changes of permanently wet concrete of various types, and the bonding of concrete to rock tunnel walls.

Modelling of radionuclide movement through a lined, backfilled and sealed repository

A preliminary modelling study of radionuclide movement through the filled tunnels and shafts of a completed repository, will be carried out to identify the data required for a quantitative assessment to be made. As data become available, this

assessment will be used to indicate the relative signification of transport through tunnels and shafts compared with that through the bulk rock. This work will be carried out in conjunction with modelling studies.

7.4.8. Sealing_of_boreholes

Proponent : NERC/IGS, Swindon Proposal : 254-81-7 WASUK

Exploratory and other boreholes, either vertical or horizontal, represent direct short-circuit routes for groundwater flow from one regime to another. Such deep boreholes will be drilled during site investigations in any rock type, and may extend from the surface or from underground cavities. In order to prevent adversely perturbing flow patterns these holes must either be totally sealed or filled with material designed to have complementary hydraulic properties with the rocks they penetrate.

A desk study will be undertaken to assess the problem and possible sealing materials. These will include combinations of natural and artificial materials, and synthetic rock precipitated in-situ. Following the desk study field and laboratory tests will be designed to validate the most suitable techniques of borehole sealing.

7.4.9. Studies_on_closing_and_sealing_boreholes_in_salt

Proponent : ECN, Petten Proposal : 226-80-7 WASN (4)

The area around the entrance of a filled burial hole must be regarded as a weak spot when considering the short term risks. It is therefore important to reduce the number of boreholes. One method to obtain this goal is to apply the "deep borehole" concept.

The following items will be treated in this study :

- a) the radiation level as a function of the distance between upper canister and mine floor level, and for different sealing proposals of the filled disposal borehole;
- b) the temperature distribution in the rock salt area around the dealing plug as a function of the distance mentioned under a) and the ventilation of the mine;
- c) the stress and strain distribution in the area mentioned under b).

In the activities mentioned under c), special attention will be paid to the stress and strain levels in order to limit cracking of the rock salt under consideration.

7.5. Characterization of internal equilibria of geological formations

Objective :

Characterization before and after disposal

- performed by means of geotechnical, hydrogeological and geochemical experiments;
- based on experimental results in-situ and mathematical models, realization of studies on the impact of :
 - the evolution of the internal equilibria of massif due to the excavation of the repository and the backfilling of it,
 - the heat release and irradiation on the geological environment,
 - the interaction between various components of the repository

7.5.1. Physico-chemical characterisation of clay : impact of heat and irradiation on physical properties and chemical composition

Proponent : CEN/SCK (B)

Proposal : 144-80-7 WASB (3.1)

The understanding of the chemical composition of the solid and liquid constituents of the Boom clay is of major importance for the interpretation of radionuclide migration phenomena. Therefore, laboratory investigation will be continued on samples taken during on site core drillings. Special attention will be paid to the influence of external factors, such as temperature increase, oxidation by air and gamma irradiation, on the physico-chemical equilibria within the clay and the consequence for its corrosion and retention capacity.

The geotechnical properties of undisturbed clay samples taken at real depth are already known at normal temperatures. Some tunneling works and later on the presence of heat emitting wastes will locally submit the clay to thermal stresses. In order to evaluate the influence of thermal cycling on the geotechnical behaviour of clay, special instrumentation will be developed to measure the variation of properties such as permeability, compressibility, shear strength etc. These tests will be performed at temperatures ranging from -25°C to + 90°C. The heat transfer experiment started in 1978 with a simulated HLW canister at shallow depth in a clay pit will be completed.

7.5.2. Evaluation of modifications induced in clays by intrusive subvolcanic bodies

Proponent : CNEN, Casaccia

Proposal : 152-80-7 WASI

Examples of pliocenic argillaceous formations that have been heated by subvolcanic bodies for geological times occur in Tuscany. It may be assumed that in some cases the heating situations occurring near future HLW repositories in clays have been more or less reproduced.

The project is directed towards the ascertainment of the maximum temperature developed by the heating body, the extension of the thermal halo in the wall rock, the mineralogic and petrographic modifications of clay with the increase of the distance from the heating source. The study will be performed on the site of Orciatico near Montecatini (Tuscany).

7.5.3. Propagation of tectonic displacements through clay deposits : numerical and experimental modeling

Proponent : CNEN, Casaccia

Proposal : 238-81-7 WASI

Sub-proponent : ISMES, Bergamo

The programme is aimed at developing and at experimentally validating mathematical models describing the propagation of seismic-tectonic displacement in clay formations. In particular, the effects in clay of tectonic perturbances affecting geological formations underlying clay formations will be considered. The programme will be accomplished on theoretical and experimental basis using specifically projected equipment. Modeling by finite elements method will be applied, using firstly available materials constitutive laws, then developing an appropriate constitutive law from laboratory testing of clay samples reproducing the supposed field conditions.

7.5.4. Thermal studies and research relating to clays

Proponent : CNEN, Casaccia

Proposal : 206-81-7 WASI (2,3)

This proposal is aimed at better comprehension of the thermal behaviour of clays, the main goals being :

- to determine the thermal properties (conductivity and diffusivity) of natural clays and their variation by increasing temperature up to 120°C;
- to measure the overpressure of interstitial fluids following the heating of clays at different temperatures;

- to ascertain the existence of anisotropies and reversibility in the thermal behaviour of clays when heated at certain temperatures;
- to validate existing mathematical models to predict the thermal behaviour of clays by heating tests and to improve them on the basis of experimental results.

The programme will be carried out both in laboratory and in situ. Natural samples in the form of plugs or large cubic blocks will be used in laboratory.

The in-situ heating experiments will be performed at a depth of 5-7 m in the area of Monterotondo, near Rome, where large deposits of marly clays are outcropping.

7.5.5. Geochemical characterisation of clay : determination of pore water composition

Proponent : CNEN, Casaccia

Proposal : 151-80-7 WASI

In-depth knowledge of the pore water composition is important for the assessment of many phenomena occurring in radioactive waste disposal in clay formations, i.e. corrosion, ionic exchange and equilibria, geochemical mobility of radionuclides, etc. There is an important lack of information about the actual composition of pore water, mainly due to the impossibility of performing direct measurements on its composition.

Experimental research is planned in order to achieve good quality results on pore water of clay formation, starting from two complementary experimental approaches, i.e. by analysing the solutions obtained

- by squeezing undisturbed clay formation samples;
- by mixing clay and water at various ratios.

By extrapolating the above experimental results the pore water composition of the considered samples will be deduced.

7.5.6. Scale effect measurement of hydrodynamic dispersion in fractured media

Proponent : CEA, Fontenay

Proposal : 147-80-7 WASF

The objective of this study is to establish, for the hydrodynamic dispersion in fissured media, the existence of an asymptotical behaviour for transport over long distances which can be predicted from that distance or short-term experiments.

The study begins with a theoretical search on dispersion in fissured media, having probabilistic character. The medium is defined in a stochastic way such as in the research for the permeability properties, starting from reconnaissance work. The propagation law of a tracer will be researched in such a medium, expressing statistical mean values.

The distances are then examined between the tracer experiments, necessary to obtain a good estimate of the propagation law for the tracer in a three-dimensional environment. The examination of the possibility of directly predicting the time for the first arrival of radionuclides at the surface is made as well as the assumption of a given distribution of all fractures in the medium.

An experimental verification will be prepared by in-situ tracer tests at various distances in a fractured medium.

7.5.7. Determination of mechanical behaviour of granite under pressure at high temperature

Proponent : CEA, Fontenay

Proposal : 146-80-7 WASF

The objective of this proposal is the determination of the thermo-mechanical parameters in order to calculate the stability of an underground opening subjected to the geostatic load and to thermal stress induced by the heat released by radioactive waste.

The first part of the study, essentially experimental, is devoted to the determination of the mechanical parameters in connection with the temperature. This will be achieved by :

- adapting the experimental system to the thermal conditions (up to 200°C);
- executing triaxial tests giving the complete behaviour of the material;
- executing dilatational and tensile tests.

In the second part of the study, the stress equilibrium in the thermoplastic zone will be calculated.

7.5.8. Statistical study on determination of permeability of fractured rock

Proponent : CEA, Fontenay

Proposal : 150-80-7 WASF

The objective of this study is to determine the fracture pattern in space of a crystalline rock mass and the uncertainty of this estimation.

After the definition of a plausible granite rock formation and its fracturation, the overall permeability of the formation is reconstructed and a suitable method (especially a geostatic one) is selected for this reconstruction.

This rock formation will then be compared to an existing one, as regards the flux of radionuclides put into solution in these rock formations. This comparison will be made during various stages and reconnaissances of the real rock formations: observation of the surface, in-depth sampling under various angles, inspection gallery and, in the longer term, a set-up of the galleries of the repository.

In conclusion, one will establish :

- a space extrapolation of methodology of fracture observations resulting from a real reconnaissance campaign of fractured rock formation;
- a precision range (or determination risk of the permeability of fractured rock) as a function of the number of available observations.

7.5.9. Study on deep fracturing of granite formations

Proponent : CEA, Fontenay

Proposal : 148-80-7 WASF

Sub-proponent : BRGM, Orléans

It is common usage to deduce the fracturation of rock formations from an examination of the surface, which is then extrapolated in-depth using vertical samples. Those samples, however, will only give an incomplete linear view of the fracturation.

In France, however, there are numerous tunnels and galleries at great depths. Those works, performed for hydro-electric plants, roadworks, railway-lines or for mining purposes, constitute ideal sites for the observation of natural fracturation at depth. Moreover, these tunnels and galleries have often been the subject of geological reports during their construction and therefore a considerable amount of literature and information is available.

For this reason the research will establish the relationship between fracturation at the surface and in-depth by direct observation and by a study of existing documents on analogous work. Most of the walls of these old tunnels and galleries are plastered or cemented and no longer lend themselves to a direct observation.

The study will include four phases :

1. Bibliographical study of the readings of the deep galleries in France :

- collection, sorting and analysis of the available documents;
- synthesis and clarification of the state of knowledge on deep fracturing;
- choice of a field study site.

2. Structural study of the fracturing in-situ :

- surface study (interpretation photo study and processing/ structural analysis on the ground);
- gallery study (structural analysis, measurement of the strains in-situ);
- synthesis and definition of the relationships between the fracturing on the surface and the fracturing in depth.

3. Geostatistical study

4. General synthesis :

Depending on the results of the geostatistical study and the structural study, the evaluation work on the surface and in-depth fracturation will be defined in order to establish guides, permitting the forecast of fracturation for formation, whose accessibility is more difficult to permit direct observations.

7.5.10. Hydrogeological and geotechnical properties of granite

Proponent : NERC/IGS, Harwell Proposal : 128-80-7 WASUK (3,4)

Hydrogeology studies

The measurement of the hydrogeological properties of the granite should provide information on those properties of the

rock and water systems which control the migration of fluids through permeable media.

A generic study will be made of rock porosity values as a function of rock type, depth, degree of alteration, proximity to major fissures and thermal history. A variety of techniques (liquid resaturation, mercury porosimetry, and injection of low melting alloys under pressure) will be used.

Combined fissure and intergranular rock porosity are amongst the controlling factors on the rate and volume of groundwater flow which affects chemical retardation of nuclides and physical dispersion during flow. Data on the fluid filled porosity will be used to model these factors and the effect of diffusion into static pore space.

Hydrogeological models will continue to be developed to provide the necessary generalised framework within which predictive assessments can be made of any individual or generalised site.

The results from these investigations will be combined with the mechanistic interpretative results derived from each of the detailed borehole studies from other sites.

Characterisation of geotechnical properties

Measurements of geotechnical properties should provide data on the stress at depth and on geomechanical charge which may occur in the near-field of a waste repository. Therefore an investigation will be made of the thermomechanical properties of crystalline rocks under conditions which they would be subject to in the very near field of a high level waste repository. Rock samples up to 100 mm diameter and 250 mm length will be deformed inside a large triaxial cell at temperatures up to 200°C and confining pressures up to 70 MPa. The cell is designed so that several dependent variables can be monitored simultaneously.

The following studies will be carried out :

- creep response of the rock to elevated temperature in the presence of a fluid phase similar to that which would exist around the waste canisters;
- change in sonic velocity across the rock specimen with changes in time, confining pressure, strain rate and temperature;
- change in porosity and permeability of the rock specimen with changes in time, temperature and pore fluid pressure using a pressure pulse attenuation technique and by measurement of the changes in volumetric strain;
- effect of deformation, elevated temperature and pore fluids on the strength of the rock and on its microcrack density,
- effect of deformation on the thermal conductivity and expansivity of the rock specimens;
- effect of temperature and time on the elastic properties of the rock.

7.5.11. Interaction of fluids, rocks, grouts and waste under repository conditions

The aim of this research is to provide experiment data on the near-field effects of high temperature and pressure on the repository components (waste, canister, backfill, rock and groundwater) and to establish the indications of these effects on nuclide release.

Laboratory studies will be carried out of the interactions between waste form, rock and groundwaters under pressure and temperature conditions appropriate to final disposal. The following factors will be investigated :

- Chemistry of the leachate in simple waste form (glass or as otherwise specified)-water systems over the pressure and temperature range 100-350°C, 30-100MPa. The dissolution

behaviour of glass will be monitored and the saturation behaviour of various waste components in solution under fluid flux conditions replicating actual disposal will be measured.

- The formation of new materials (such as clay and feldspar) on the waste surface under these conditions will be investigated. Work to date has already shown that these selectively incorporate certain waste elements into their structure. The extent of this phenomenon and the stability of new minerals will be investigated.
- The effects of adding rock materials to the waste/water system will be investigated. These include perturbations in water chemistry and formation of additional stable mineral assemblages.
- Extension of the above work to include engineered nearfield components such as canister materials and potential buffer/backfill media.

Interpretation of the thermal effects on rock and groundwater chemistry in the near and far fields (as function of time after disposal) will be carried out by reacting the rock with water at various pressure and temperature conditions. Additionally a computer programme will be used to enhance the understanding of reaction kinetics effects, and to fill in data between experimental "points" using available thermo-dynamic data. A detailed study of the near field geochemical environment will involve the study of factors such as chemical compatibility of near-field repository materials with host rock, their buffering potential against corrosion of canister materials and the ability to provide a geochemical barrier against nuclide migration and thermal stability.

7.5.12. Thermal effects on groundwater movement and rock stresses

Proponent : UKAEA, Harwell

Proposal : 154-80-7 WASUK

The aim of the research is to study the effect of heat released by the high level waste on the groundwater movement and on the stresses in the rock. The following experiments will be carried out :

Heat transfer experiments

The data already obtained over 15 m distances with low (3 kW) and medium (10 kW) heater power during the past two years will be extended to about 30 m distances with a high power (18 kW) test for 24 months.

Permeability experiments

The 200 m deep, rotary drilled and back flushed, cored hole is now completed and effective permeability measurements are being carried out in it using an improved multi-packer technique. This hole and others to be drilled by the percussion method at distances of about 5, 10, 20, 40 and 80 m from it will be used to study forced water flow over these distances through the fracture pattern. Measurements will be made of the hydro-static pressure field produced through the rock by injection of water at pressures up to 1MPa to determine variations in the effective permeability with position and direction. The movements of tracers with high water flows between holes will be studied to determine flowing porosity.

Thermal rock and fluid mechanics experiment

Access has been obtained to a mine in which underground tests will be made of both thermal effects and nuclide migration. Measurement of the hydraulic conductivity of a fracture before, during and after heating will also be made of the strain

and elastic moduli both during heating and cooling. An attempt will then be made to relate the hydraulic and mechanical data. Suitable tracers and fission products will then be added to the water flow through the fissure to study the extent to which there is diffusion into the rock.

7.5.13. In-situ heating experiments in fissured rock

Proponent : CEA, Fontenay

Proposal: 149-80-7 WA

The objective of this proposal is to determine in-situ the thermal convection generated by the heat load of the waste and to verify the theoretical and laboratory results obtained so far.

A 0.5 kW variable heating element will be installed at level - 100 m in one of the existing boreholes, a level with a major fracture in the rock, which is detected beforehand by video sampling. By means of water injection tests in the same borehole it will be verified that this fracture communicates easily with the surrounding boreholes. It is foreseen to drill three supplementary boreholes down to -100 m to increase the observation points. The heating element will also be provided with a device, by which an electrolytic tracer can be injected into the fracture. Temperatures, resistivity, heating power and source temperature will be recorded on an analogous computer with periodic interrogation.

The heating power will be chosen so that the thermal convection in the fracture will be of a higher order of magnitude than the natural flow in the fracture without heating.

The results obtained will be interpreted by modelling the experiment on the thermal convection model "fractured milieu", developed in the preceding research programme.

7.5.14. Influence of fluid rock interaction on the rheology of rock salt

Proponent : University of Utrecht Proposal : 153-80-7 WASNL

Salt rock deforms by a variety of mechanisms. Different mechanisms prevail when different conditions or mean stress, temperature, deviatoric stress, strain-rate and pore pressure apply.

A number of experiments will be carried out with an apparatus specifically designed for this project, permitting pressures up to 500 bars and temperatures up to 400°C. In a first series of experiments with dry salt rock samples, brittle processes and crystal plastic processes will be studied.

In the second series of experiments fluid will be made available during the experiments to the rock salt specimens. The pressure of the "porefluid" will be systematically varied, and flow-through experiments under various hydraulic gradients will be attempted.

The following factors will be studied :

- enhanced or suppressed dilatant behaviour because of the presence of water;
- enhanced or suppressed ductility and an attempt to relate such behaviour to diffusion processes;
- the effect of the presence of water on mass transport processes.

7.5.15. Suitability of the Konrad iron mine for the disposal of radioactive waste

Proponent : GSF, Braunschweig Proposal : 145-80-7 WASD

The R&D programme carried out so far has proved the feasibility of radioactive waste disposal in the Konrad iron mine from the geological point of view.

On the basis of the geoscientific, technical and radiological results the new investigation programme shall deliver a detailed evaluation on the isolation of the wastes to be disposed by natural (claystone) and backfilling barriers. For the proof of the efficiency of those barriers laboratory tests for the determination of the sorption capacities of various claystones and backfilling materials are important. The in situ tests for the identification and for quantity measurements of water migration paths in these largely impermeable rocks are based on ventilation tests and geoelectrical measurements.

The structural integrity of the site will be determined by most sensitive rock mechanical and geophysical investigation methods of which some are still in a developing phase concerning their use in underground galleries. The result of these investigations will end up in predictive modelling of the deformation behaviour of the rock formations in and around the repository site.

By the wide range of technical experiments the concepts for waste handling and disposal developed so far will be examined, in particular with regard to the radiation dose of the working personnel. Working areas and operating stages where higher dose rates are possible, will be identified.

The disposal test with inactive waste casks of different sizes and weights will be carried out together with the backfilling test, for which specific technical equipment has to be constructed using dry materials only.

7.6. Migration of radionuclides in the geological formation

Objective :

Deterministic assessment of the liberation and the migration of radionuclides in the geosphere.

7.6.1. Migration of radionuclides in clay formations

Proponent : CNEN, Casaccia

Proposal : 208-81-7 WASI

This proposal is aimed at investigating the migration of radionuclides in clays with a special emphasis on diffusion phenomena which seem very important in the long term, when the artificial barriers (glass matrix and container) slowly dissolve and radioactivity is released from the repository to the geological barrier.

A procedure will be developed to measure the apparent diffusion coefficient and to correlate the diffusion behaviour of some radionuclides with mineralogic composition and ion exchange properties of clays.

In the preliminary test synthetic clays, prepared by consolidating pure clay minerals in special designed compaction units, will be used. The mineralogic composition of these synthetic clays will continuously increase in complexity to finally reach that of natural clays. The diffusion of Cs, Sr, I and Ni will be investigated.

7.6.2. Migration of radionuclides in clay

Proponent : CEN/SCK, Mol

Proposal : 144-80-7 WASB (3.2)

Apparent diffusion coefficients for the Boom clay were already

determined in various conditions in an early stage of the programme. A realistic laboratory scale approach for radionuclide migration consists of conducting diffusion experiments. An instrumentation allowing diffusion tests on reconsolidated (up to 20 bars) and heated (up to 80°C) clay plugs of 5 cm in diameter and about 3 cm in length, will be set up. The first experiments are foreseen to run with tritium and iodine tracers in order to evaluate the retardation effect due to the clay matrix without sorption and to consequently deduce the molecular diffusivity. Later on, the experiments will be performed with actinides and more in particular with Pu, Np and Am. In a final stage, actinide traced borosilicate or other glasses will be brought in contact with simulated groundwater, and the leachate mixed with various elements representative of corrosion products (Fe, Ni ...) of canister and structural materials, tested for diffusion.

This part of the Belgian programme is harmonized with the Italian one. Some laboratory tests will be performed on Italian clays at CEN/SCK, whilst samples of Boom clay will be examined in the CNEN laboratories.

7.6.3. Physico-chemical factors concerning ion migration in granite or in its alteration products

Proponent : CEA, Fontenay

Proposal : 203-81-7 WASF (1-3)

This study will provide information on the retention power of the considered natural medium (granite) and of its deterioration products.

The first part of the study deals with transport phenomena in granite and the determination of coefficients to be used for the description of these phenomena (K_a and K_D). These coefficients will be measured by impregnation tests of granite granules of different grain size or by percolation tests on compact cylindrical granite samples - all this for certain radionuclides in aqueous solutions.

The second part concerns the retention of radionuclides by deterioration products. This consists of laboratory measurements on the nature, the repartition and the sorption properties of these deterioration products and the evaluation of their influence on radionuclide transfer in granite.

The third part will consist of an in-situ determination of the transfer of radionuclides in fissured granite to verify the above-mentioned laboratory tests. The experiments will at first start in unfilled fractures using Sr and Np.

7.6.4. Physico-chemical behaviour of transuranic elements in granite formations

Proponent : CEA, Fontenay

Proposal : 210-81-7 WASF

This study investigates the fixation and migration of transuranium elements in geological formations as a function of their equilibrium between their solid and liquid phases. The nature of these elements is closely linked to the physico-chemical properties of the geological environment.

The presence of some complex organic or mineral agents will modify the fixation and migration properties. For certain elements, e.g. plutonium, the presence of polymers has to be taken into account.

The research programme will be centred on :

- measurement of fundamental properties like the Eh- pH diagram for Np and Pu as a sulphate, carbonate or fluoride;
- study of the retention of certain transuranics with specific valences (Np IV, Np V, Pu III, Pu IV, Pu V) as a function of pH and a complex environment (Cl⁻, SO₄⁻, PO₄⁻, F⁻, CO₃⁻⁻); this study will be performed on three silico-aluminates (bentonite, illite and attapulgite);
- study of colloidal forms and polymers of Pu and its formations on preferential salts;

- determination of the solubility of different salts of Tc;
- measurement of diffusion profiles in granite with an ion detector;
- study of the preferential fixation on various components of granite by auto-radiography and ion detector, with the objective to determine the constituents of granite which retain preferentially the transuranium elements.

7.6.5. Nuclide migration studies in granite

Proponent : UKAEA, Harwell

Proposal : 209-81-7 WASUK

The study of radiological problems of the disposal of high level waste in geologic formations carried out by NRPB under the first Community programme indicated that transport of nuclides by ground water is one of the most important factors in determining release rates to the environment. The transport process includes convection, dispersion, decay and "sorption". The term "sorption" is used here to refer to various hold-up mechanisms including ion exchange, precipitation and colloid filtration. It is these hold-up mechanisms which are the subject of this chemistry study where major attention is given to the extent of sorption zones and colloid movement.

1. The work on the solution chemistry of actinides will be concentrated on the following areas :
 - basic solution chemistry appropriate to groundwater conditions;
 - analytical methods for identification of species in solution;
 - study of naturally occurring actinides and daughter nuclides (especially ²²⁶Ra) in groundwater;
 - sorption of actinides on microscopic particles and colloids either found in groundwaters or produced by leaching of vitrified waste.

2. Studies of physico-chemical effects will be carried out, on sorption-desorption kinetics using pieces of rock several centimeters thick. Firstly, because of their simpler chemistry, Sr and Cs will be used. Then, as information on solution chemistry becomes available, the work will be extended to the actinides.

3. The main step of field experiments will be :

- conventional hydrological tracing studies;
- use of naturally occurring elements e.g. Sr and Cs, to study the behaviour of particular waste forms;
- extension of step 2 using short-lived radioactive species as tracers.

The experiments will include a variety of forms of the different elements such as simple salts, complexes, colloids and fine particles.

This work will proceed in a number of distinct stages with each step requiring consultation with local bodies and safety assessment and clearance by the government organisations.

7.6.6. Sorption characteristics of the rock formation of the Konrad mine

Proponent : GSF, Braunschweig Proposal : 145-80-7 WASD (1)

The objective of this proposal is to perform geoscientific and radiochemical laboratory and in-situ tests for characterising the natural condition of ion migration in the iron-ore/clay environment of the Konrad mine.

By means of hydrogeological rock mechanical and geoelectrical measurements the chemical behaviour and the migration parts of water in a low permeable geological formation will be deter-

mined. Changes induced by means of mining work and storage operations will be examined. The results from these studies are important for a valuation of a possible interaction waste/containment on the one hand and the geological medium on the other hand.

Sorption measurements on the iron ore and also on the overlying claystones will be carried out. Special attention will be paid to the chemical behaviour of the transport medium and to waste typical and preselected transuranic nuclides. These laboratory investigations are necessary for the classification of the potential of nuclide retention by rock and clay minerals.

With the results obtained so far, it will be possible to draw up diffusion models.

7.6.7. Transport of radionuclides along salt grain boundaries

Proponent : Utrecht University Proposal : 153-80-7 WASN (3)

The programme consists of a sequence of experiments dealing with the transport of ions along grain boundaries in salt. Individual ionic species, such as Sr^{2+} or Ca^{2+} , are introduced through the pore fluid inlet pipes and diffusive transport under confining pressure, deviatoric stress and temperature will be assessed.

The experiments will run up to one week duration. The salt core will then be sectioned and the following work carried out :

- examination with the scanning electron microscope to assess element redistribution and by use of doped salt, efficiency of diffusive mass transfer mechanisms during deformation;
- use of atomic absorption spectroscopy to determine trace element distribution maps;
- ion probing to determine trace element location in the micro-structure.

The transfer of nuclides is most likely to take place along the boundaries between different crystal grains in the salt rock. Therefore, special techniques will be used to determine small element concentrations in the regions of grain boundaries.

7.7. Mathematical Modeling

Objective :

Modeling of the behaviour of the geological environment using stress, hydraulical and ion transfer mathematical models. Coupling of the different models should allow to precise the degree of incertitude of the simulation and the sensibility to various parameters.

7.7.1. Development and adaptation of existing models for heat transfer, waterflow, stresses and migration of radio-nuclides into clay formation

Proponent : CEN/SCK, Mol Proposal : 144-80-7 WASB (3.3)

Basic work on mathematical modeling was previously started for heat transfer and radionuclide migration evaluation into the clay. The simple models developed during the past pluriannual programme will be adapted and completed as a function of available experimental data.

Other models will be adapted on specific scenarios and used for evaluation work in the following fields :

- convective water movements into clay due to the presence of heat sources;
- water flow into the various aquifers above the clay formation;
- mechanical stresses around tunnels excavated into plastic clays.

Coupling of models will be tested, for instance the heat transfer model with the radionuclide migration model and the model for waterflow into an aquifer.

7.7.2. Development of mathematical models on heat transfer in clays

Proponent : CNEN, Casaccia Proposal : 206-81-7 WASI (1)

Sub-proponent : ISMES, Bergamo

A mathematical model describing the heat diffusion in clay will be developed. This model will take into account the variations of the thermal properties as a function of temperature and of any possible mass transport induced by thermal gradients.

The models will be validated with the results of the in-situ heating experiments performed in the area of Monterotondo.

7.7.3. Research on precipitation and dissolution of silica in the fractures of granite under influence of thermal gradients; experimental data establishments

Proponent : CEA, Fontenay Proposal : 200-81-7 WASF

The objectives of this proposal are to analyse, both by experimental and theoretical approaches, the precipitation and dissolution of silica in the fractures of a crystalline rock, under the influence of thermal gradients, and to evaluate the possibilities of self-sealing of the fractures resulting from these mechanisms.

In the theoretical part of the study, a dynamic model of the dissolution-precipitation phenomena will be developed, taking into account :

- thermal power produced by the waste;

- heating and thermal conductivity of the environment;
- convection circulation, produced by this heating;
- dissolution-precipitation of silicium for a whole range of reaction kinetics;
- variation of the width of fractures because of this dissolution-precipitation;
- variation of circulation velocities because of the changes in the width of the fractures, etc.

A sensitivity analysis of the mechanism of the self-sealing of the present parameters, in particular the kinetics of the dissolution reaction (precipitation) will allow, before tackling the experimental phase, to display the parameters to be determined.

During the experimental phase, estimations of the kinetics of precipitation and dissolution will be carried out in the laboratory. Measurements will be taken after having undergone conditions of pressure, temperature and physico-chemical states close to the real conditions. This should be done either in reactors (up to 100 atm. and 250°C) or by percolation under pressure (up to 150 atm. and 150°C).

7.7.4. Validation by means of tracer experiments of an existing three-dimensional model on radionuclide migration in granite

Proponent : CEA, Fontenay Proposal : 213-81-7 WASF

This work deals with the validation of an existing migration model by means of the tracer experiments which are performed on granite, gneiss or schiste. The transport model was developed in the previous programme.

The experiments will be performed firstly on massif K and then in new deep boreholes.

A simulation of the confining capacity using some sensitive radionuclides will be performed on the most promising geological formation site.

7.7.5. Further development of model on heat transfer, ground water flow, radionuclide transport and rock mechanics in granite formations

Proponent : UKAEA, Harwell

Proposal : 209-81-7 WASUK (6)

The object of this work is to develop a set of related mathematical models for the physical processes important in the burial of radioactive waste in rock, in particular for heat transfer, groundwater flow, radionuclide migration and rock mechanics.

Each of these phenomena would be modelled on one or more of the four size scales, single can, single tunnel, repository and region, and over time ranges corresponding to repository construction, the thermal phase and the ultimate decay. The models will be validated by analytical work, compared with laboratory and field experiments and with models developed elsewhere. In particular close ties will be kept with other parts of the UK programme and mathematical support will be provided for other programmes to help in the planning and interpretation of experiments.

The modeling work will concentrate on the development of two separate computer codes : NAMMU for groundwater flow and heat transfer and NAMTAR for migration of radionuclides. Both of these codes are aimed at modeling on a regional scale, but they will also be able to be used for comparison with small scale experiments.

7.7.6. Development and application of rock-mechanical computer codes on the strength behaviour of heated and unheated salt rocks

Proponent : GSF, Clausthal

Proposal : 130-80-7 WASD (1.8)

Mining activities during construction and operation of a repository and the heat production of disposed waste result in stresses and reactions of the host rock, which are to be calculated by means of Finite Element or Finite Difference Methods.

Special emphasis has to be put on the creep behaviour of the rock-salt as regards the long-term reaction of the disposal field. The creep behaviour is highly dependent on the temperature, so that temperature fields in rocks subject to changes in space and time must always be considered when making calculations in order to be able to specify the local relationship between stress, creep velocity and temperature through the use of the constitutive law.

The mechanical strength behaviour of rocks under these conditions must be shown, whereby a failure criterion is required.

The following studies will supplement the required information:

- Existing codes will be extended and adapted to the salt-mechanical conditions of the repository.
- Mechanical strength criteria (fracturing etc.) are to be given which must serve as a basis in case of failure.
- The constitutive law of rock-salt, which also takes creep effects at different temperature into account, has to be improved by means of rock-physical and rheological data obtained from other tasks.

The codes will be applied to :

- the development of a reference repository model for all further calculations;
- in-situ and supplementary pilot tests;
- the description of thermally induced near- and far-field tectonic motion processes;
- prove whether a new diapirism is possible.

7.7.7. Final improvement of the existing computer codes for the determination of the temperature fields in a salt dome repository

Proponent : KFK, Karlsruhe

Proposal : 130-80-7 WASD

The computer codes developed will be optimized with respect to accuracy, economy and flexibility.

The objective of the future activities is to integrate the existing codes to a system of codes, which is capable of taking account of the boundary conditions expected in a repository and to combine near-field details and far-field aspects. The effect of loading sequences, limited storage area and of the ventilation of the galleries in the repository will be considered in particular.

The programme consists of the following activities :

- development of computer codes with special regard to boundary conditions dependent on time;
- modification and expansion of existing codes to improve their flexibility and feasibility;
- performance of calculations for different repository designs as a basis for rock mechanics analyses;
- performance of parameter studies and calculations for the planning and evaluating of the temperature field tests in the Asse salt mine.

7.7.8. Development of calculation models on the thermo-mechanical interaction of salt with the borehole casings and with the waste canisters.

Proponent : KFK, Karlsruhe

Proposal : 130-80-7 WASD (2.2)

Numerical methods are being developed for the study of the thermomechanical interactions between high-level waste canisters and the surrounding salt, the borehole lining and backfill material.

The codes which are to be developed must consider complex nonlinear material behaviour as well as complex geometries and boundary conditions. They must be highly effective with respect to calculational economy and accuracy.

On the basis of laboratory experiments, stress-strain laws for rock salt and buffer materials will be formulated and integrated into the existing computer codes.

The programme consists of the following activities :

- expansion and improvement of the existing computer codes with special regard to different conditions of stress and strain, limited material strength, intrusion of brine or water, accuracy and economy;
- testing of the developed computer codes;
- performance of calculations relevant to convergence of the boreholes, pressure loading of the waste canisters and buffer materials, effects of brine intrusions and inhomogeneities in the salt.

7.7.9. Diffusion calculation for selected radionuclides in the geological and operational system of the Konrad mine

Proponent : GSF, Braunschweig

Proposal : 145-80-7 WASD (4)

One-dimensional calculations on the diffusion of radionuclides

in the geological and operational system of the Konrad mine will be carried out.

Models for the diffusion of radionuclides in the iron ore, overlaying work and backfilled galleries will be constructed.

A parametrical study for a multidimensional diffusion model will then be started up.

7.7.10. Development of a computer programme for calculating detailed and global displacements of the mine floors, of the whole salt dome and of the surface ground level above the disposal mine

Proponent : ECN, Petten

Proposal : 226-81-7 WASN (2)

Heat of the radioactive waste disposed of in a salt dome will cause vertical displacements of the ground level and will in consequence impose stress on the strata overlying the top of the salt domes. The stability of the mine galleries and the area around the shaft are also important for the safety during the operational phase of the repository.

A computer programme will be developed to permit model studies on this subject.

7.8. Risk analysis

Objective :

Evaluation of the capability of various geological formations to isolate the radioactive waste from the environment, due note to be taken of additional artificial barriers.

7.8.1. Safety analysis of the Mol site

Proponent : CEN/SCK, Mol

Proposal : 144-80-7 WASB (4)

The research covers two lines :

- the probabilistic evaluation study of the geological containment, specific to the Boom clay at the Mol site;
- the deterministic evaluation study of the repository evolution and geological containment, specific to the repository design of the Mol site.

The probabilistic evaluation is a continuation of the research already started during the previous programme. For the present programme it concerns the consequence analysis of some important release scenarios, identified previously by Fault Tree Analysis technique. This study is performed in close collaboration with the JRC Ispra.

The deterministic repository evolution will consist of a first description of a scenario of natural evolution of the repository. This scenario will be based on the results and conclusions of research in the field of waste/rock interactions (corrosion, leaching, migration,...). It has to define the amount of radionuclides released from the clay formation and to perform also the subsequent consequence analysis.

7.8.2. Geoprospective study of a repository site : natural evolution of the site

Proponent : BRGM, Orléans

Proposal : 222-81-7 WASF

A lot of work is going on the subject of storage and disposal of nuclear waste into geological continental formations; however, few studies have yet been undertaken to find out precisely the natural evolution of a repository. This evolution is controlled by numerous factors such as seismicity,

tectonics, climatology, the interactions of which are numerous and complex and the influences of which on a site's integrity may be weak or strong, useful or dangerous.

This study aims at taking this aspect of the disposal problem into account.

The three-step study deals with :

- an inventory and qualitative study of significant factors;
- the quantification of the factor's action;
- the hierarchisation and combination of the factors with a probabilistic approach; this latest stage includes the making of models intended for evolution simulations; then an attempt will be made to quantify the effects and express each possible evolution in terms of risk function.

As an exemple, it is proposed to study the case of a "paleosite" evolution over 10^5 years of a chosen site.

The results thus obtained should be considered as the basis of a method which can later be applied to concrete cases of geological zones where radioactive waste storage and disposal might be planned.

7.8.3. Study on long term stability of salt domes

Proponent : Battelle Institut, Frankfurt Proposal : 223-81-7
WASD

The uncertainty concerning the long-term stability of salt domes should be overcome by an investigation of post glacial observable movements of the surface above salt domes. From observations of the earth's surface above salt domes, it can be concluded that upward movements have occurred since the last ice age, since these movements lead to uneven uplifts of the earth's surface, to which, if the time scale is known, rates of development can be attributed. These uplifts are to be identified by means of terrain inspections, chart studies

and the perusal of reports and interpreted in respect of their cause. In particular, the question of apparent movements, which seem to have occurred as the result of a displacement in the reference level, is to be studied.

The investigation will be performed at salt domes where surface movements have been observed or whose seismic profile gives grounds to expect a movement observable on the surface. The investigation will cover salt domes in Germany, the Netherlands and Denmark.

The stability and/or the movements of typical salt domes will then be checked.

7.8.4. Drafting of a final safety report for the repository of HLW in the final mine concept in a salt dome

Proponent : ECN, Petten

Proposal : 221-81-7 WASN

Updating of the Dutch repository concept has to be carried out with respect to evaluations and technical developments in this field.

Due to the fact that only general information is available of the Dutch salt domes with regard to, for instance, the geo-hydrological area, this study will be generic. The study will be improved as soon as salt dome specific data become available.

As far as the short-term risk analysis is concerned, the consequences of accidents during the time the mine is in active operation are to be analysed from concrete data with respect to the lay-out of the repository and the procedures applied for disposal operations.

Data which play an important part in a short-term risk analysis are, e.g. :

- the dimensions and the lay-out of the disposal roadways;
- the ventilation system of the mine;
- the drilling and mining activities, the transport system in general and the underground transport of HLW canisters in

particular;

- the disposal operation with which HLW canisters will be emplaced in the deep boreholes;
- the way in which the disposal boreholes after filling are sealed and closed or not.

As regards the long-term risk analysis, the history of salt diapirism in the Dutch salt domes and investigation of the upward movement of those diapirs that have reached a post-diapiric stage will be studied. This study will provide an important datum for the estimation of the isolation value of a salt dome and for defining a future radionuclide release scenario.

The following items are subjects of a sensitivity analysis :

- the isolation capacity of the salt dome versus a) some geohydrological parameters, and b) the thickness of the isolation shield;
- the delay in the geosphere as a function of different depths at which the radionuclide release may start.

Attention will also be paid to transport phenomena of radionuclides in the deep subsoil in case of a break through the isolation due to a constant subsrosion of the salt dome.

7.9. Repository design

Objective :

Design and project of operational repositories. Control and monitoring after sealing of the repository.

7.9.1. Engineering studies relating to a waste disposal facility in clay

Proponent : CNEN, Casaccia

Proposal : 225-80-7 WASI

Sub-proponent : ISMES, Bergamo

The main goals of this proposal, which is not addressed to a specific site, are :

- to define by means of a conceptual study the reference waste disposal facility based on both alternatives presently under consideration in Italy for the emplacement of radioactive wastes in clays : a matrix of deep holes drilled from the surface or a system of mined galleries with holes at low depth;
- to assess on the basis of existing mining technologies the feasibility of the facility.

The programme will develop by the following phases :

- definition of the fundamental hypotheses, i.e. general characteristics of the relevant clay formation, quantities and types of waste , maximum permissible temperature, etc.;
- thermal analysis based on a parametric study on the main factors affecting temperature distribution;
- far-field and near-field analysis of the thermomechanical response of clay formations to excavation and emplacement of a nuclear waste repository;
- conceptual study of the repository and evaluation of the mining technologies to be used.

7.9.2. Further design work on a repository in a salt dome

Proponent : ECN, Petten

Proposal : 226-81-7 WASN

Various configurations for disposal of reprocessing waste were

studied in the previous programme in order to obtain an insight into the temperature effects by spreading the waste in a given geometry. The successful dry-drilling experiment in the ASSE-II mine has shown that a repository with 300 m long boreholes is feasible in a salt formation.

The present proposal is focused on a one-layer mine concept with a storage capacity which is sufficiently large to hold the amount of solidified high level waste derived from reprocessing of spent fuel that originates from 40 years of operation of 25 LWR's of 1000 MWe each.

The repository is of the one-layer type with deep burial holes. The mine galleries from where the burial holes are drilled will be situated at a depth of about 900 m below ground level. In principle, two different geometries of the salt dome will be studied : a cylindrical shaped salt dome with a flat top and a cone shaped salt dome with a flat top.

As a starting point the deformation behaviour of virgin salt domes without geometrical disturbances (no mining activities) will be studied. These calculations intend to show how large the influence is of the surrounding strata on the salt dome, and what the effects are of the dome geometry and creep behaviour of the salt on the deformation phenomena.

The stability of the mine galleries and the area around the shaft foundation during the time the repository is in active operation, are important for the safety of the personnel involved. These problems shall be the subject of model studies by means of computer calculations.

7.10. Improvement of methods for assessing the potential of geological disposal

7.10.1. Review of mathematical models for site selection

Proponent : Atkins

Proposal : 219-81-7 WASUK

The study consists of a detailed review of the calculation methods, embodied in computer programmes, which are presently available for the selection and design of suitable sites for the disposal of radioactive waste in geological formations. Aspects which will be considered will include structural analysis, internal stress and temperature fields, hydraulic equilibrium, the transfer of ions in the geosphere and the coupling of all these effects with regard to the internal equilibrium of the formations.

The study will be carried out in several stages:

- The first stage will be to identify which aspects of site selection and design are amenable to mathematical modeling.
- The different types of mathematical model and numerical technique which could be employed will then be considered and existing computer programmes using these methods will be identified.
- A number of the programmes will be selected for running certain test cases which will be carefully defined.
- The test runs will then be carried out and programme performance noted in terms of cost, ease of use, sensitivity, accuracy, etc.
- Finally, the results of the entire study will be assessed and recommendations will be made on the use of existing programmes, areas for improvement and the need for new programmes on certain aspects.

8. IMMOBILIZATION AND STORAGE OF GASEOUS WASTE

8.1. Introduction

This action deals with the management of radioactive materials removed from process off-gases and in particular from the dissolver off-gas of fuel reprocessing plants (including tritium, although a major part of tritium is associated with liquid effluents), namely :

- iodine-129 (long-lived) and aerosols (containing numerous radionuclides, including long-lived ones), the removal of which is current practice;
- krypton-85 and tritium for which the practice of discharge to the environment will be restricted and which should then be isolated for a period of about a hundred years;
- carbon-14 (long-lived), if its discharge to the atmosphere proves to be inappropriate.

The following work has been carried out under the first Community programme (1975-1979):

- research on the immobilization of krypton, tritium and iodine by incorporation in solid materials, including a half-scale pilot plant testing for a krypton immobilization process;
- studies on the storage and on the sea disposal of krypton contained in pressurized cylinders;
- preliminary development of two processes for isotopic concentration of tritium;
- experimental studies of the gas release during reprocessing head-end operations;
- assessment studies of possible management modes for iodine-129 and krypton-85.

Under the second Community programme (1980-1984) the most promising conditioning methods have been selected and will be further developed with a view to industrial application. Work on aerosol removal is added as a new subject, aiming at reducing the consumption of high-efficiency filters.

The main subjects of the present programme are :

- krypton-85 immobilization and storage/disposal : continuation, with a view to industrial application, of the work started under the previous programme;
- tritium separation and immobilization : further development of at least one separation process; selection and development of at least one immobilization method;
- iodine-129 immobilization and disposal : development of a method for immobilization; study of the influence of the disposal mode on the long term environmental impact;
- aerosol filtration : study of techniques aimed at a reduction of the waste volume.

8.2. Krypton immobilization in a metal matrix

Proponent : UKAEA, Harwell Proposal : 157-80-8 WASUK

The aim of this research is to complete the development of the process for the immobilization of krypton in a metal matrix by combined ion implantation and sputtering.

The construction and successful commissioning of the 50 kW pilot plant in the previous Community programme has demonstrated the process on a scale comparable with that required for an industrial plant. The operating parameters and efficiency are similar to those predicted. An assessment of the properties of the matrix has confirmed that this should satisfy the safety

requirements for the transport, storage and disposal of radio-krypton arising from fuel reprocessing.

The objectives of the proposed work are :

- to prepare and fully test gas-filled deposits of candidate matrix materials to ensure that the gas will be retained throughout the required storage period under all envisaged conditions;
- to further develop the immobilization process and equipment;
- to carry out a design and costing study for a small transportable test rig to demonstrate the process under full active conditions.

8.3. Fixation and storage of krypton-85 in zeolites

Proponent : KfK, Karlsruhe

Proposal : 158-80-8 WASD

This proposal deals with the long-term storage of radioactive krypton in zeolites 5A. Although the pores interconnecting the zeolite 5A cages are larger than the krypton atomic diameter at 520°C krypton is trapped in the matrix by chemical pore closure. The degree of loading is proportional to the fixation pressure.

In spite of the progress achieved in recent years, there is still need for further work being undertaken in the second programme :

- Further optimization of the fixation conditions : screening tests to select an adequate zeolite matrix and work to further improve the autoclave design as well as the fixation concept.

- Stability of the conditioned gas : investigation of the stability of krypton encapsulated in zeolites 5A towards elevated temperature, the decay product rubidium, leaching and radioactive radiation. Experiments with a specific radioactivity comparable to that expected during final storage are foreseen.
- Thermal conductivity of loaded zeolites : these measurements are needed to estimate the design of the final storage vessel.
- Development of the fixation process : a technical scale plant will be designed including cost estimate of the process.

8.4. Occlusion and storage of Krypton in solids

Proponent : University of Antwerp Proposal : 234-81-8 WASB

Basis of this research proposal is an advanced process that produced a stable fixation of xenon, krypton and other gases in aluminosilicates.

The programme of the proposed research project foresees :

- optimization of the developed fixation process with respect to adsorption temperature, adsorption pressure, sample pre- and post-treatment, matrix structure and reaction circumstances, in order to increase the stability of gas-solid systems and to obtain faster immobilization processes;
- investigation of the new gas immobilization technique in order to specify the conditions of krypton fixation;
- study of the stability of the gas-solid systems with respect to temperature, pH, leaching, long-range effect on the environment (including residual partial pressure);
- development of accurate assay methods for the fixed gaseous radioactive waste as well as the level of rest-release.

8.5. Liquid metal embrittlement of container materials by rubidium

Proponent : UKAEA, Harwell

Proposal: 227-81-8 WASUK

A plant in which radioactive krypton is handled and stored may be particularly at risk for liquid metal embrittlement (LME) because the rubidium daughter product has a melting point of 39°C. Present knowledge of embrittlement by rubidium is almost non-existent.

The proposed study will screen candidate structural materials for susceptibility to LME. Tensile tests under conditions most likely to cause embrittlement will be carried out in liquid rubidium on several materials selected in consultation with other participants of the Community programme.

8.6. Separation of tritium from aqueous effluents

Proponent : CEN/SCK, Mol

Proposal : 159-80-8 WASB

This proposal concerns the continuation of work on the tritium separation process studied under the first Community programme. The so-called ELEX process produces tritium enrichment in a two-phase system using a combination of electrolysis and catalytic exchange.

Several batches of hydrophobic catalysts will be produced and subjected to quality control. Special attention will be paid to the reproducibility of the production and to the influence of batch size and shape and size of the catalyst. Quality control will be carried out by determination of the catalytic activity in bubble-bed and trickle-bed reactors and by appro-

appropriate characterization methods such as measurement of platinum surface and hydrophobicity.

The small (1.4 kW) integrated detritiation unit, which was designed previously, will be built. After a first demonstration of the ELEX process by detritiation of water containing representative amounts of tritium, a more extensive study will be carried out, the evaluation of which will allow an optimum technical realisation of the ELEX concept.

A larger pilot installation (80 kW) for detritiation of water will be designed, constructed and tested.

Further exploitation of the larger pilot installation in 1983 and 1984 and eventually integration in the pilot reprocessing installation being built at SCK/CEN is foreseen.

8.7. Tritium separation from aqueous effluents of a nuclear fuel reprocessing plant

Proponent : KfK, Karlsruhe

Proposal : 160-80-8 WASD

This research proposal concerns an enrichment process for tritium by catalytic exchange between hydrogen and water in a counter-current column.

The work performed under the first Community programme will be complemented by testing the hydrophobic catalysts for possible damage due to tritium radiation.

A comparative evaluation will be made of the performances of two different catalysts. The lay-out of a technical enrichment plant will be presented considering different tritium enrichment factors and tritium yields.

8.8. Assessment of waste management options for iodine-129

Proponent : NRPB, Harwell

Proposal : 161-80-8 WASUK

Iodine-129 has a half-life of 16 million years; there seems little possibility of preventing its eventual release to the environment where it would act as a long-term source of low-level exposure to the world's population. Even so, attention needs to be given to waste management schemes to control the time and place of entry of iodine-129 into the biosphere, and to control the resulting radiological impact.

A one year preliminary study was made by UKAEA/CEA/NRPB of the waste management options for iodine-129 and their radiological impacts. This proposal for extension of that study is aimed at improving the estimates of the radiological impact, hence providing a more reliable technical basis for arriving at judgements on a waste management strategy for iodine-129.

Existing radiological models will be refined and extended where necessary. The radiological impacts of the iodine-129 management options defined in the preliminary study will be re-evaluated.

The radiological impacts of the various schemes will be contrasted and their relative merits identified. The sensitivity of the conclusion of the study to judgements of the importance attached to collective doses delivered over extremely long timescales and at very low levels of individual dose will be evaluated.

8.9. Carbon-14 waste management assessment study

Proponent : UKAEA, Harwell and Proposal : 163-80-8 WASUK
NRPB, Chilton

The objective of the proposed study is to provide the necessary basis for formulating the R&D required on carbon-14 waste management.

Most carbon-14 is currently discharged to the environment; in the context of an expanding nuclear programme consideration needs to be given to alternatives to discharge. Carbon-14 waste management has received only limited attention. Its separation and immobilization are normally assumed to be straightforward but this is by no means certain bearing in mind the lack of information on its behaviour in reprocessing plants, its possible interaction with processes required for separating other species, its long half-life and its chemical difference from most fission products. Moreover most of the studies on carbon-14 have only recently been carried out and the information from them needs assimilation.

The study will include consideration of the behaviour of carbon-14 in nuclear plants and its radiological impact. Criteria and options for all stages of waste management will be developed and assessed in a European context. Areas of ignorance will be identified. The study will incorporate new thinking without duplicating previous reviews.

8.10. Examination of fibrous prefilters for droplets and particulate aerosols

Proponent : KfK, Karlsruhe

Proposal : 162-80-8 WASD

To clean off-gases with a high radioactive inventory from nuclear facilities (e.g. in reprocessing), filters and devices are necessary to pre-clean the off-gases to a great extent. Therefore pre-filters, which are safe in operation and which allow remote replacement will be developed to prolong the life of the non-regenerable HEPA-filters.

The studies are first focussed on the verification of the behaviour of solid and droplet aerosols at recleanable, packed fiber mist eliminators and their optimization. Tests with radioactive and inactive aerosols will be performed in order to determine the following characteristics of the packed filter mist eliminator :

- loading time, distribution and liquid storage as a function of the gas flow and the aerosol concentration;
- pressure drops occurring at different flows;
- optimum amount of liquid for cleaning the filter element;
- determination of the removal efficiency as a function of the droplet and solid aerosol sizes.

8.11. Aerosol filtration by regenerative metal filters at elevated temperatures

Proponent : CEN/SCK, Mol

Proposal : 228-81-8 WASB

The aim of this research proposal is the determination of the filtration characteristics of metallic fibrous packed bed filters, including their regeneration by blow-back or spray washing techniques in view of reducing the consumption of HEPA filters and minimising secondary waste. These filtration characteristics will be determined mainly for aerosols in the near micron size range.

In the first part of the programme, the intrinsic filtration characteristics will be measured using monodisperse latex aerosols and polydisperse methylene blue aerosols. In the second part, actinide containing aerosols will be used, such as they are produced by evaporation or calcination of spray droplets containing dissolved actinide compounds. The inlet concentration of these aerosols in the process stream at high temperature will be kept high in the presence of water vapour and of nitrous oxides. The regeneration in situ of the filters will be tested.

8.12. Volume reduction of discharged active filter material

Proponent : University of Pisa Proposal : 229-81-8 WASI

The proposed study aims at an exhaustive definition of the importance and size of the problems due to the volume of active filter materials discharged at the present time and in the near future.

In a status report a critical analysis will be made concerning the existing prescriptions and industrial standards for construction and operation of ventilation systems in nuclear plants.

ANNEX

MEMBERS OF THE ADVISORY COMMITTEE ON PROGRAMME MANAGEMENT

(during 1980)

<u>BELGIUM</u>	L. BAETSLE M. MATTHYS P. DE MEESTER
<u>DENMARK</u>	K. BRODERSEN B. SKYTTE JENSEN
<u>GERMANY</u>	K. HUBENTHAL R. KROEBEL H. ILLI K. RÜHN
<u>FRANCE</u>	A. BARTHOUX M. GRAS Y. SOUSSELIER
<u>IRELAND</u>	J.D. CUNNINGHAM
<u>ITALY</u>	A. BRONDI A.G. FACCHINI G. ROLANDI G. RUSSINO
<u>LUXEMBOURG</u>	P. KAYSER
<u>NETHERLANDS</u>	J.L. BAAS P. HAGEDOORN B. VERKERK
<u>UNITED KINGDOM</u>	D.W. CLELLAND F. FEATES K. KEEN
<u>COMMISSION</u>	M. CARPENTIER S. ORLOWSKI F. CACCIA DOMINIONI M. BRESESTI

related titles of interest

RADIOACTIVE WASTE MANAGEMENT

An International Journal

Edited by D. R. Anderson, Sandia Laboratories, A. M. Platt, Battelle Pacific Northwest Laboratory, and Francesco Girardi, Joint Research Center-ISPRA

POST-ACCIDENT HEAT REMOVAL

Edited by V. Coen and H. Holtbecker

FISSION GAS BEHAVIOUR IN NUCLEAR FUELS

Edited by C. Ronchi, Hj. Matzke, J. v. d. Laar and H. Blank

RADIOACTIVE WASTE MANAGEMENT AND DISPOSAL

Proceedings of the First European Community Conference Luxembourg, May 20-23, 1980

Edited by R. Simon and S. Orlowski

RADIOACTIVE WASTE : ADVANCED MANAGEMENT METHODS FOR MEDIUM ACTIVE LIQUID WASTE

By K. W. Carley-Macaulay, R. G. Gutman, E. W. Hooper, J. A. Jenkins, A. D. Turner, P. F. Wace, P. Chauvet, J. P. Gauchon and T. Dippel

RADIOACTIVE WASTE DISPOSAL INTO A PLASTIC CLAY FORMATION

(A Site Specific Exercise of Probabilistic Assessment of Geological Containment)

By Marco d'Alessandro, Commission of the European Community, J. R. C. Ispra (Italy) and Arnold Bonne, Centre d'Etude de l'Energie Nucléaire Studiecetrum voor Kernenergie, Mol (Belgium)

MANAGEMENT OF PLUTONIUM CONTAMINATED WASTE

Edited by J. R. Grover

 **harwood academic publishers**

61 GRAYS INN ROAD, LONDON WC1X 8TL
POSTSTRASSE 22, CH-7000 CHUR, SWITZERLAND
POST OFFICE BOX 786, COOPER STATION, NEW YORK, N.Y. 10276

ISSN : 0275-7273

ISBN : 3-7186 0115-X