

29/3

# euratom

bulletin of the european atomic energy community

march 1965 vol. IV no. 1

CS  
81  
AD  
PST

1965 March - no 1  
Library Text

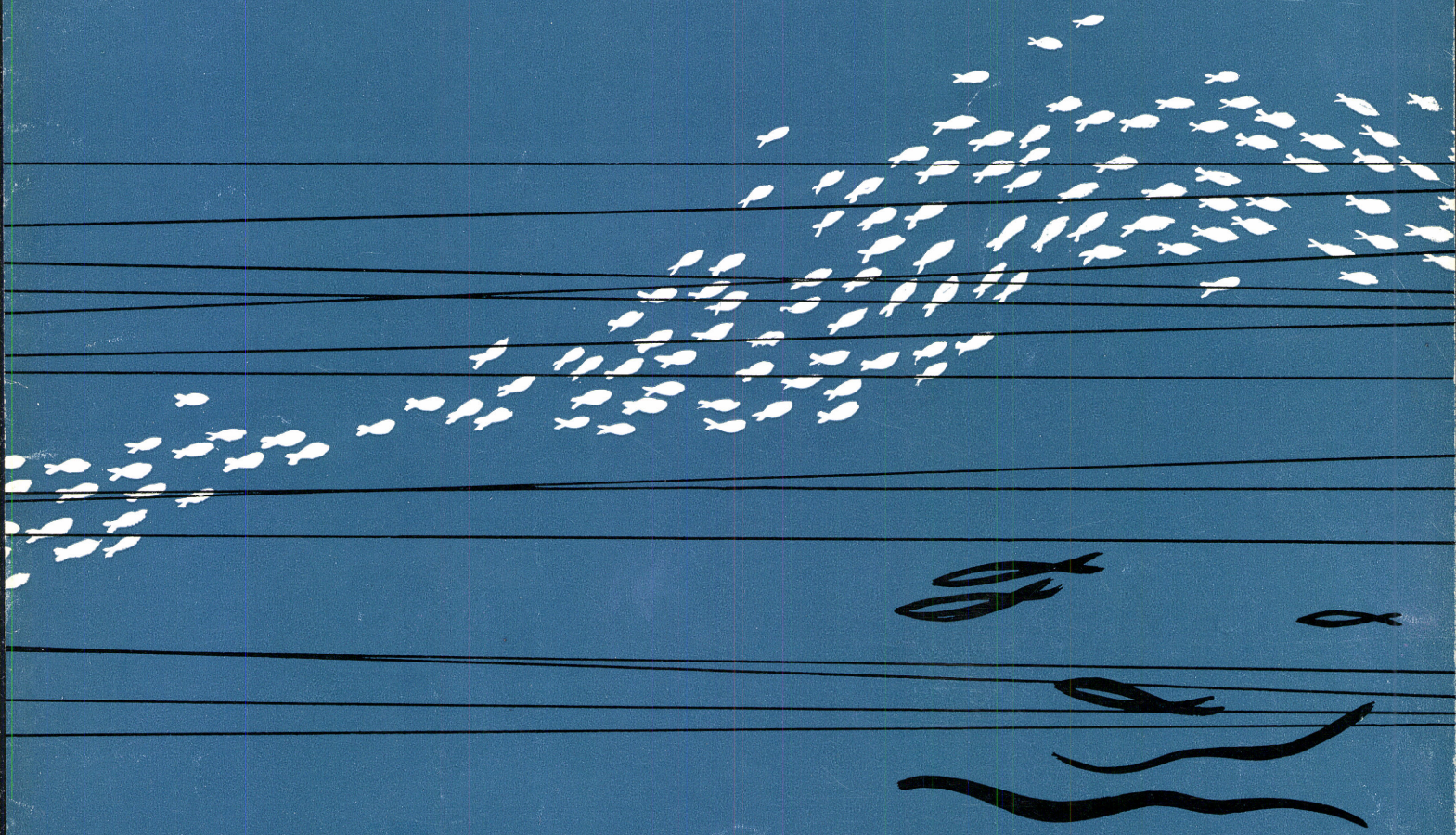

506:26





Quarterly Information Bulletin of the European Atomic Energy Community (Euratom)

# 1965 - 1

The Community's mission is to create the conditions necessary for the speedy establishment and growth of nuclear industries in the member States and thereby contribute to the raising of living standards and the development of exchanges with other countries (Article 1 of the Treaty instituting the European Atomic Energy Community).

radioisotopes radioisotopi radioisotopen ship propulsion schiffsantrieb propulsion navale propulsione navale scheepsvoortstuwing biology biologie biologie biologia biologie medicine medicin médecine médecine a geneeskunde health protection gesundheitsschutz protection sanitaire protezione sanitaria bescherming van de gezondheid automatic data processing automatische informatie information automatique informazione automatica automatische verwerking van gegevens insurance versicherungswesen assurances assicurazioni verzekeringen economics wirtschaft économie economia économie education and training ausbildung enseignement insegnamento onderwijs en opleiding power reactors leistungsreaktoren réacteurs de puissance reattori di potenza energie reactor en nuclear fusion kernverschmelzung fusion nucléaire fusione nucleare kernversmelting radioisotopes radioisotope radioisotopi radioisotopen ship propulsion schiffsantrieb propulsion navale propulsione navale scheepsvoortstuwing biology biologie biologie biologia biologie medicine medicina geneeskunde health protection gesundheitsschutz protection sanitaire protezione sanitaria bescherming van de gezondheid automatic data processing automatische informatie information automatique informazione automatica automatische verwerking van gegevens insurance versicherungswesen assurances assicurazioni verzekeringen economics wirtschaft économie economia économie education and training ausbildung enseignement insegnamento onderwijs en opleiding power reactors leistungsreaktoren réacteurs de puissance reattori di potenza energie reactor en nuclear fusion kernverschmelzung fusion nucléaire fusione nucleare kernversmelting radioisotopes radioisotope radioisotopi radioisotopen ship propulsion schiffsantrieb propulsion navale propulsione navale scheepsvoortstuwing biology biologie biologie biologia biologie medicine medicina geneeskunde health protection gesundheitsschutz protection sanitaire protezione sanitaria bescherming van de gezondheid automatic data processing automatische informatie information automatique informazione automatica automatische verwerking van gegevens insurance versicherungswesen assurances assicurazioni verzekeringen economics wirtschaft économie economia économie education and training ausbildung enseignement insegnamento onderwijs en opleiding power reactors leistungsreaktoren réacteurs de puissance reattori di potenza energie reactor en nuclear fusion kernverschmelzung fusion nucléaire fusione nucleare kernversmelting

To-day there can be no two opinions about the vital role that nuclear energy is destined to play in meeting our electricity requirements. Inevitably and irrevocably, electricity producers will be constrained to set up more and more power reactors within our Community.

On the other hand, it can scarcely be claimed that the use of nuclear reactors for marine propulsion has gained such a firm foothold. Whereas land-based power reactors already run into tens, so far only two nuclear-powered merchant vessels, the *NS Savannah* and the ice-breaker *Lenin*, are sailing the high seas.

Nuclear marine propulsion has on occasion given rise to impassioned discussions, during which arguments far exceeding the bounds of reason have been advanced for or against its development. The present issue contains an outline of what is being done in this field in the European Community. It shows that the Community has judged the economic outlook for nuclear marine propulsion to be propitious enough to warrant programmes not confined to paper studies but extending to concrete achievements. A case in point is the launching last year of the *Otto Hahn*, which is shortly to be equipped with its reactor.

No illusions are entertained concerning the ability of the *Otto Hahn* to pay its way as a merchant vessel, this being regarded primarily as a large-scale experiment designed to yield information and not profits. It must however be stressed that through this information and that derived from other Community research projects, it will be possible to blue-print the successor to the *Otto Hahn*. Then will be the time to think exclusively in terms of profitability.

EUBU 4-1

# Nuclear Measurements

JOZEF SPAEPEN,

Director of the European Central Bureau for Nuclear Measurements, Geel (Belgium)

The results of careful measurements have often been the starting point for the discovery of new fields of research and for the development of new scientific ideas.

Advances in technology, also, are closely dependent on accurate measurements: without them, for example, the large scale production of interchangeable mechanical parts in the automobile industry would be impossible.

Measurement is inconceivable without standards. If a petrol pump attendant pours out five gallons into your tank and charges you for six, you are unlikely to accept the explanation that he has invented a standard gallon of his own. Scientists and engineers, while not concerned, of course, with this kind of deliberate falsification, are however interested in avoiding inaccuracies in their measurements, arising from other causes, such as human error, faulty apparatus, etc. A ruler nominally one metre long may have been produced in perfectly good faith; it may have been made to correspond as exactly as possible to the standard metre (now defined as a certain number of wavelengths corresponding to one of the lines of the optical spectrum of krypton-86), but for certain measurements demanding high accuracy it will prove inadequate, for example because its markings are too thick or simply because it has buckled.

When it comes to designing nuclear reactors, this problem of accuracy is often very sensitive: although there is a considerable body

of knowledge at hand on what happens in a nuclear reactor, there is still much work to be done on the determination of exactly how it happens.

We admittedly no longer have to face the large uncertainties which the designers of the Chicago CP1 reactor, the first reactor ever to go critical, had to face. The problem today consists less in making reactors work than in turning them into economical instruments for the production of power. In these circumstances it is no longer sufficient to put into a reactor enough fissile and

moderating material, for instance, to be sure of obtaining a given effect; accurate data have to be secured in order to know how little is actually needed.

Measurements and standards are therefore essential.

## The Central Bureau for Nuclear Measurements (CBNM)

It is not surprising, in the light of these remarks, to find written into the Treaty

Figure 1a: The CBNM's linear accelerator.

Electrons are produced in the electron gun (1) and accelerated. Only the two accelerator sections shown (2) have been installed at the moment, but further sections could be added in future if required. The electron beam is directed at the uranium target (3) and produces bremsstrahlung, which in turn generates neutrons. The beam can either be directed straight at the target or deflected (4) so as to impinge on it vertically. This second possibility offers the advantage of complete symmetry in the horizontal plane for all flight paths.

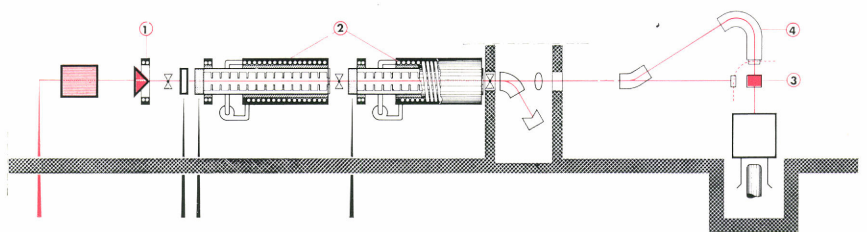

instituting the European Atomic Energy Community the creation of a standards bureau specialised in nuclear measurements. In 1960, this bureau was established in Geel near the Mol Nuclear Centre in Belgium. It is in fact one of the four establishments of Euratom's Joint Research Centre.

The basic idea was to set up a laboratory at the European level which would play in the nuclear field a part similar to that played on a broader scale by standards institutes such as the National Bureau of Standards (U.K.), the Laboratoire d'essais (France), (U.S.A.), the National Physical Laboratory the Physikalisch-Technische Bundesanstalt (Germany), etc.

As the principal aim of the European Atomic Energy Community is to promote the establishment of an European nuclear industry on a sound economic basis, one of its tasks is to render power reactors competitive. In the design stage the "optimisation" of such reactors calls for the availability of very accurate neutron data. It is therefore natural that the CBNM should also devote a large part of its efforts to measuring neutron parameters of interest to nuclear industry.

In view of the many neutron data still lacking or inaccurately known, the contribution of the CBNM necessarily remains fairly modest. For this reason the CBNM set up a committee composed of Community experts in the field of neutron measurements and reactor physics. This committee screens requests for reactor data and helps to co-ordinate measurements in progress or planned in the laboratories of the Community in order to fulfill such requests. This co-ordination is carried out in close co-operation with the European-American Nuclear Data Committee (EANDC), which has four delegates from the Community, one of whom is in the service of the Euratom Commission. Moreover, the initial planning of important CBNM laboratories was done in direct collaboration with EANDC.

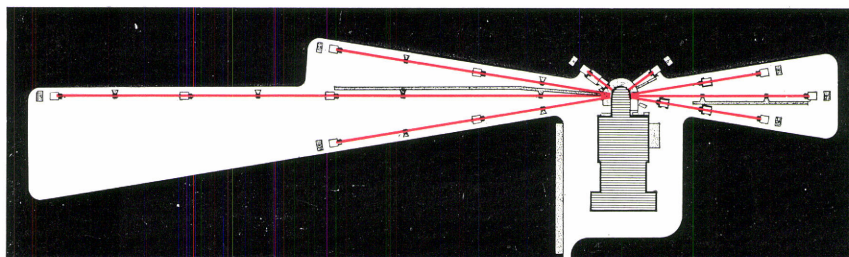

Figure 1b: The linear accelerator building and the eight neutron flight paths being installed at the moment, the longest of which is 400 metres long. Thanks to the fact that the machine can give very short bursts (as short as  $10^{-8}$  seconds) and to the availability of long flight paths, it is possible to distinguish neutrons of different energies (i.e. velocities) with a good degree of accuracy (see figure 1c).

As will be shown later, two other sectors are of particular interest in reactor design: fissile and stable isotopes on the one hand, and radioisotopes on the other. Two laboratories of the CBNM are active in these sectors.

Absolute measurements of nuclear parameters require samples which are very well defined as regards chemical analysis, isotopic composition and total mass, in order to know the number of atoms present of a given isotope. The CBNM has consequently organised auxiliary services for conventional metrology, chemical analysis and optical spectrometry which are equipped with the best modern instruments available.

#### "Integral" or "elementary" data?

In accordance with the general objectives of Euratom it is clear that much of the work of the CBNM is devoted to neutrons. An important decision had to be made as regards the kind of measurement to be performed, since different types of measurement require fundamentally different equipment. The question was: should the CBNM

be equipped for "integral" data or for the determination of "elementary" neutron parameters as a function of the incident neutron energy?

The reactor designer has to predict the behaviour of reactors of entirely new design or of variants on existing types. Before he can do this, he must have information at his disposal about the interaction of neutrons with the materials in his reactor. Most of this information is given in the form of neutron "cross-sections", each of which is a measure of the probability of a particular phenomenon involving neutrons of a particular energy with a particular material.

Calculations could, in theory, be performed on a purely mathematical basis if all the elementary data were known with sufficient accuracy. In practice, however, these calculations are very complicated and many elementary data are not yet available or are not accurate enough.

Consequently, the predictions of reactor physicists are still very often based on simplified theories, and the necessary data are obtained partly by "integral" measurements on critical assemblies which are very similar to the reactor system under study.

Figure 1c: The principle of neutron energy measurement by "time of flight" (with due apologies to specialists in the field).

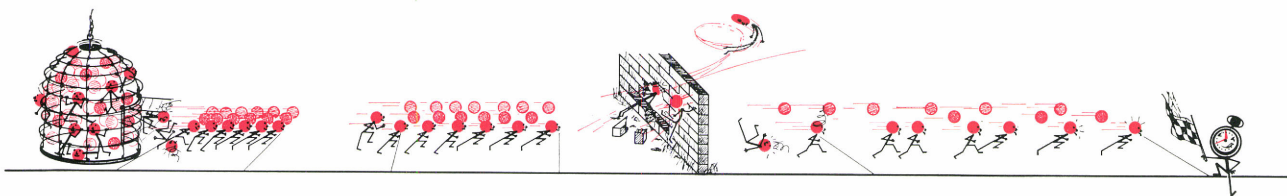

Critical assemblies are, however, expensive and limited in their application. This becomes evident when account is taken of the large variety of factors which play a part, such as different types of fuel, cladding moderator, etc.

There has therefore always been a general tendency to use neutron physics theories and data wherever possible and to combine them with the results of integral measurements. This is a tendency which the availability of fast computers has strongly accentuated in recent years. Reactor designers are consequently requesting more and better elementary data, and this is one of the reasons why the equipment of the CBNM was chosen for measuring neutron parameters as a function of energy.

Another reason for this choice was that neutron energy spectra in critical assemblies are inadequately known and that the methods available for determining them inside such assemblies are in need of considerable improvements. In many cases, measurements of integral values therefore depend on particular geometries and cannot very accurately be referred to fundamental quantities. On the other hand, it was felt that a standards bureau should always refer its results to well-defined conditions, which are much easier to establish for elementary than for integral data.

Furthermore, interest in the European Community has in recent years been focused on fast reactors. Designers are in great need of data on neutrons of intermediate energy in the "resonance" region. They also need, in the case of fast neutrons, more

information on the scattering which occurs when the neutrons collide with the atomic nuclei of both fissile and structural materials.

These considerations have led to the choice of a powerful linear accelerator, with very short bursts of electrons and long neutron flight paths (for high resolution work—see figures 1a, b and c) and of a pulsed and bunched Van de Graaff accelerator (see figure 2).

The CBNM is still in the building and installation stage, but results have already been obtained. Some examples will serve to illustrate the sort of work the Bureau is undertaking.

It should however be stated at the outset that, although a standards bureau is organised into departments, each one of which has its own responsibilities, it is not possible to follow this organisational pattern when describing its work. This is because there is hardly any project which does not require the close collaboration of practically all these departments: laboratories for neutron measurements, mass-spectrometry laboratory, radioisotope counting laboratory, conventional metrology laboratory and the department responsible for the preparation of samples. Let us look at some of these projects.

#### Research on boron

As an example of a study on a standard frequently used in neutron cross-section measurements, mention may be made of the research conducted on boron. This is at the

Figure 2: Part of the CBNM's Van de Graaff installation.

The experiment under way is aimed at determining the elastic and inelastic neutron scattering cross-sections of a particular material. Neutrons are shot at the sample (at the centre of the coloured circle) and the detector (on the right) registers results for the particular angle at which it has been placed. The detector is heavily shielded to prevent stray neutrons from interfering with the experiment.

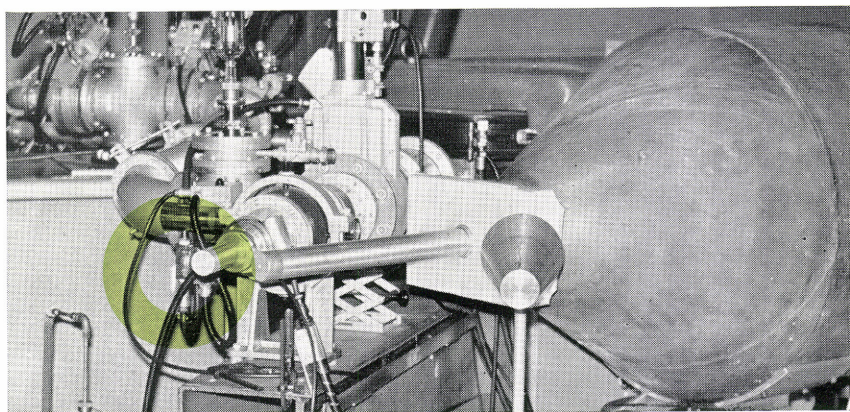

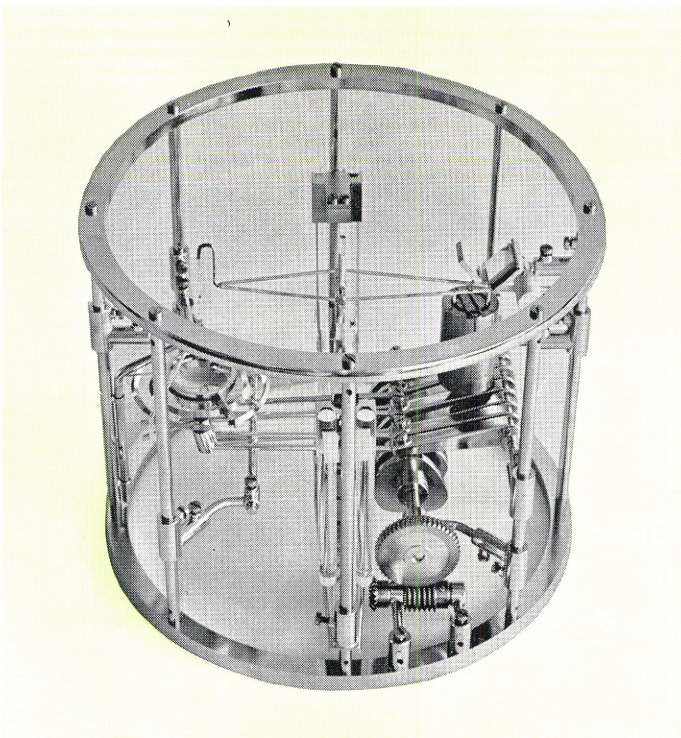

Figure 3: Some of the samples produced at the CBNM are made by evaporating the material under vacuum. Parts of the vapour condense as a thin film on a support.

In cases where it is necessary to determine precisely the total mass of the layer it is often imperative to weigh the sample *in situ*, i.e. in the vacuum chamber itself. This is done to avoid effects which influence the mass.

same time not only a typical example of the team-work, involving various disciplines, which is often necessary when absolute measurements have to be made, but also illustrates the Bureau's collaboration with national organisations, since part of the research was done jointly by the Bureau and the Belgian Nuclear Studies Centre using the BR 1 reactor.

Boron has been widely used as a reference substance for cross-section measurements. Not only does it have a large absorption cross-section, but the regularity with which this absorption varies as a function of the energy of the impinging neutrons, within quite a large energy range, makes it a good reference material. The CBNM accordingly undertook systematic investigations with the aim of producing a stock of standard boron, with accurately known properties.

As a first step, a careful determination was made of the isotopic composition of natural boron obtained from various existing stocks of standard boron at laboratories in North America and Western Europe. Considerable differences between those "standards" were detected. Besides these relative measurements, the absolute isotopic composition of a 10 kg stock of natural boron was determined. This involved a large effort to detect systematic errors in two of our mass spectrometers of different design, which finally resulted in the availability of standard stocks of natural boron with well-defined and identical isotopic composition at the CBNM and the National Bureau of Standards in

Washington. It is now generally recognised in North America and in Western Europe that, in order to avoid waste of scientific effort, boron reference samples should be drawn either from the CBNM or from the National Bureau of Standards in Washington.

The CBNM is prepared to provide, on request, various kinds of standard boron solutions and even accurately-known boron films. In this connection an extensive study was undertaken on the preparation of thin, uniform, pure boron films, the weight and composition of which are accurately known. For this purpose, an evaporating unit in which the boron heated by electron bombardment was developed. The boron layers are very accurately weighed in vacuum. Concurrently with the mass-spectrometric research, an accurate re-measurement of the thermal  $(n, \alpha)$  cross-section of boron-10 was performed—the reaction is:

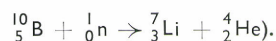

At the time this investigation was started, large discrepancies existed between careful measurements of recent date.

Two samples of deuterated boric acid solution in heavy water, containing respectively 19.81% and 96.51% of boron-10, were measured. The results for the  $(n, \alpha)$  cross-section, as derived from the two measurements, agree extremely well, being respectively  $3840 \pm 11$  and  $3837 \pm 9$  barn. The cross-section was thus established to an accuracy of  $\pm 0.3\%$ .

### Fissile isotope standards

Another example of the work being done on standards for neutron measurements is the study of foils containing a precisely known quantity of a fissile isotope (e.g. uranium-235, plutonium-239). Reactor designers insist on knowing the fission parameters of neutrons at thermal energies with greater accuracy. One of the main reasons why better accuracies are difficult to achieve is the difficulty of carrying out a precise determination of the weight and the isotopic and chemical composition of the fission foils used in the measurements. At present, foils prepared by different techniques (evaporation, electro-spraying, painting) and tested by counting the  $\alpha$ -radiation emitted by the fissile isotopes give diverging results. The CBNM is trying a different approach by preparing the foil under high vacuum and weighing it *in situ* without breaking the vacuum, so that no oxidation can occur (see figure 3).

### Fast neutrons

With the help of the Van de Graaff accelerator with which the CBNM is equipped, fast neutrons can be obtained. It is therefore a precious tool for obtaining the data needed by the designers of fast reactors. Data are, for instance, being measured on the inelastic and elastic neutron scattering cross-sections of iron and a number of other materials which will be present in these reactors.

### "Threshold" reactions

The Van de Graaff accelerator is also being used for the determination of the "activation" cross-sections of "threshold" reactions, such as  $^{58}\text{Ni} (n, p) ^{58}\text{Co}$  or  $^{27}\text{Al} (n, \alpha) ^{24}\text{Na}$  (see figure 4).

The interesting feature about these reactions is that they occur only if the impinging neutrons have a certain minimum energy (hence the name "threshold" reactions). Thus, if a sample of nickel-58, for instance, is placed at a particular spot in a reactor for a particular length of time, it is possible to deduce from a measurement of the amount of radioactive cobalt-58 formed the number of neutrons of an energy superior to the "threshold" energy which have passed this spot.

Obviously, experiments making use of

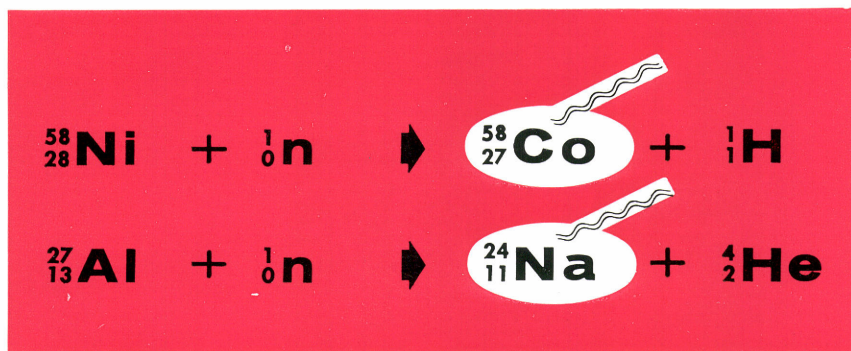

Figure 4: Two typical "threshold" reactions.

these "threshold" reactions are pointless unless it is known at what rate they occur for a given neutron flux, i.e. unless their "activation cross-sections" have been carefully measured. This is precisely what the CBNM has undertaken to do for a large number of these reactions.

### Dosimetry

As the products of "threshold" reactions are radioactive (e.g. cobalt-58 in the example quoted), the exact quantity formed can be measured indirectly by counting the radiation emitted by the sample—assuming that the counting equipment used has been accurately calibrated. This is yet another problem which it is the role of a standards bureau to solve.

The problem is actually not confined to the fairly special case of threshold reactions



Figure 5: Several of the CBNM mass spectrometers.

but applies to all reactions exploited by physicists for in-pile dosimetry, such as the  $^{59}\text{Co} (n, \gamma) ^{60}\text{Co}$  reaction, commonly used for thermal flux integration. In this particular case, for instance, the CBNM is in a position to supply radioactive  $^{60}\text{Co}$  standards, known to within  $\pm 1\%$ , thanks to which users can calibrate their counting equipment.

The CBNM's contribution to in-pile dosimetry extends beyond the supply of standards; it has set up a working group, which meets about three times a year, concerned with thermal and fast-neutron flux and spectra and with gamma-dosimetry in reactors. Representatives of nearly all nuclear energy laboratories in the Community participate in the activities of the group. One of the first results is a standard specification sheet on the use of cobalt foils and wires as integrators of thermal flux, the object being to achieve uniformity of thermal-flux integration within the Community.

### "Resonance" neutrons

The CBNM's linear accelerator has not yet been commissioned, but a programme of measurements is already being prepared.



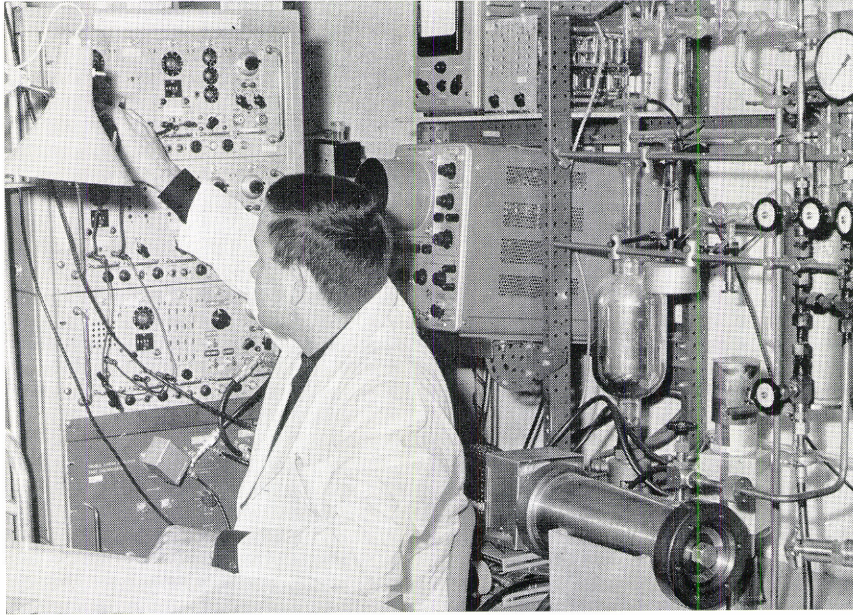

Figure 6: With the high pressure proportional counter (right-hand below) radionuclides decaying by electron capture are measured.

The principal aim is here to obtain data useful to reactor designers on neutrons in the so-called "resonance" region. Their behaviour, which differs markedly from that of either slow or fast neutrons, is still imperfectly known, and yet such information, especially data on the way they affect fissile isotopes, is of vital importance to the control of some types of reactor. The CBNM's measurements will accordingly pertain mainly to isotopes of fissile elements, including the 240 and 241 isotopes of plutonium.

#### **Absolute measurement of isotopic composition and absolute counting of radioisotopes**

From the examples which have been given, it is clear that precise measurements of neutron cross-sections are impossible without accurately known samples. Isotopic composition measurements being among the most delicate operations involved, the CBNM's mass spectrometer laboratory has made an intensive study of the means of improving their accuracy (see figure 5). Similarly absolute counting of radioisotopes is closely linked with the CBNM's measuring programme. Research has therefore been

carried out to improve absolute counting techniques (see figures 6 and 7). For instance a method for measuring the activity of water containing tritium has been developed, giving an absolute accuracy of  $\pm 0.4\%$ .

#### **Sample preparation**

Thousands of samples are prepared annually at the CBNM, not only for its own requirements, but to satisfy the needs of research scientists of Euratom's Joint Research Centre or of national laboratories and universities within the Community. A limited number is also delivered to experimenters outside the Community.

The samples prepared show a very wide variety, ranging from simple detectors of some special alloy to very thin samples of pure plutonium.

Priority is however always given to samples which are to be used for neutron measurements and which are difficult to prepare.

This last remark emphasises once more the CBNM's *raison d'être* and its determination not to be deflected from its primary task, the establishment of standards and the measurement of data needed by nuclear industry.

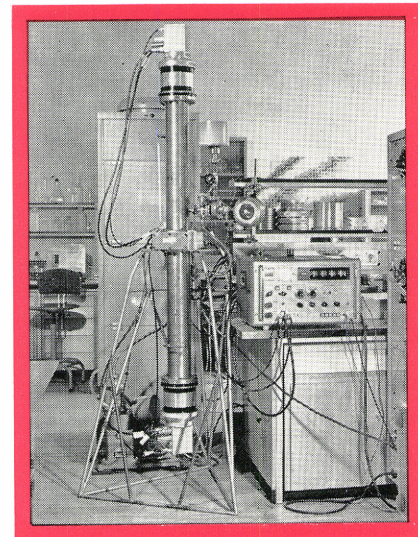
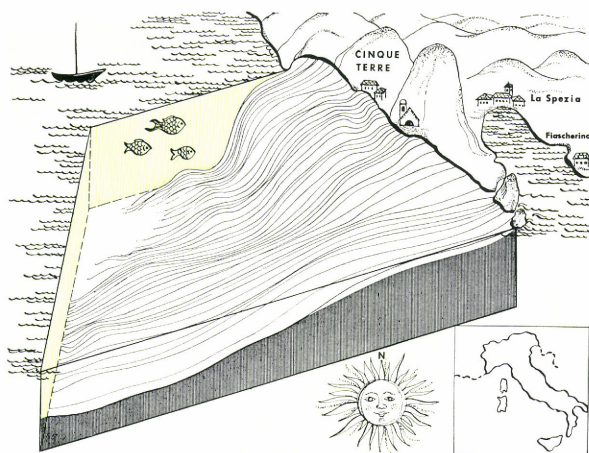

Figure 7: A "low geometry" alpha-counter.

The part of the Mediterranean Sea under investigation by the Fiascherino laboratory.



EUBU 4-2

## The atom fishers

DR. MICHAEL BERNHARD,

Director of the Laboratory for the Study of the Radioactive Contamination of the Sea, Fiascherino, Italy

Every new atomic plant which comes into operation adds to the amount of radioactive waste products in our environment.

Whether it be a stationary plant, or a mobile one in a ship or an aeroplane, the radioactive waste it produces has to be stored away in a safe place.

Even if this is done, the possibility of leakage cannot be ruled out. Moreover, it is regular practice to discharge some radioactive products into rivers and into the sea, in an extremely diluted form, admittedly, but not in a way which can be simply ignored. Finally, accidents can and, unfortunately, are bound to happen. Contamination of our environment by dangerous radioactive substances is therefore a reality which has to be faced.

There are many ways in which these radioactive wastes can threaten our health, but they are perhaps at their most dangerous when they actually enter the human body, since at present there are practically no methods available for eliminating them from the body tissues. Once a man has been contaminated by these radioactive substances, he will be continually exposed to the destructive effects of their radiation—until such time as the radioactive atoms have either decayed or been exchanged with stable atoms from his food and drink, processes which may both take considerable time.

The best way of protecting man is therefore to prevent the radioactive substances from entering his body in the first place.

This entails finding out how radioisotopes can get into the body. The most obvious way is through food and drink, but it should be added that respiration opens up entry through the lungs and that, to a limited

extent, we can absorb substances through our skin.

It follows that the most straightforward approach to protection against internal radiocontamination would be to keep a continuous check on the radioactivity of all our foods and beverages and to put a halt to their consumption on the first sign of radiocontamination. A little reflection will show that this straightforward approach has serious limitations in practice. What would happen if, all of a sudden, all the food of a large city or country were contaminated? Starvation would hardly be a satisfactory solution to the problem. It is clear that we must know in advance what could cause such a disastrous contamination in order to prevent it from occurring at all.

To do this, we have to look more closely at our food and find out where it comes from, how it is produced and, obviously, how it can become radiocontaminated.

Man's food comes from several sources: milk, meat, eggs, etc. are produced by animals, domestic or wild, terrestrial or aquatic. Flour, vegetables, fruits, sugar, etc. are produced by plants, which might likewise be either cultivated or wildgrown. Thus all foods, with the exception of drinking water and salts, are produced either by plants or by animals. If we go on to examine the food of animals we will find that they in their turn feed either on plants (herbivores) or other animals (carnivores) or on both together (omnivores). The various "food chains" involved are extremely complex but, luckily, only a few of the animals and plants included in them serve as human food. In fact, the majority of our food is produced in agriculture, where the food chain is artificially reduced by man to a minimum length in order to obtain the highest yield possible.

Fig. 1 gives a scheme of such an agricultural food chain.

Agricultural products being an essential part of our diet, a large number of research projects covering the ways in which they can become radioactive are being carried out today.

But man does not consume agricultural products only. Seafoods, for example fish, shrimps and mussels, can play a more or less important role in his diet according to his habits or the place where he lives. Certain parts of the population, such as fishermen, or inhabitants of coastal regions, eat considerable amounts of fish and sometimes, as in the case of parts of Ireland and the Far East, also marine plants.

In this respect it is unfortunate that relatively little is known about the sea and its organisms. How they feed, what they eat, where they reproduce, how they migrate, and so on. In fact, the study of the oceans in general, and not only in connexion with radiocontamination problems, is considered an "underdeveloped science". Consequently, this lack in general and fundamental knowledge about the food relationships between marine animals and plants, nutrients, currents and light conditions, the latter being so very necessary for the plants as a primary energy source, inflict serious limitations on the prediction of hazards due to accumulation of radioactive substances by these organisms and their transmission to man via the seafoods he eats.

This ignorance becomes alarming if we remember that the sea is being considered a potential dumping place for radioactive wastes and that in the near future an increasing number of nuclear powered ships will certainly be crossing the oceans.

Even with the best intentions to prevent accidents they are bound to happen sooner or later.

In view of this situation and, more particularly, of Italy's long coastline, the *Comitato Nazionale per l'Energia Nucleare* created in 1959 a special laboratory: the *Laboratorio per lo Studio della Contaminazione Radioattiva del Mare*.

The laboratory is situated at Fiascherino on the beautiful rocky coast to the south-east of the port of La Spezia. At present, the personnel of the laboratory consists of five qualified scientists and a supporting staff of 14, not counting the guest scientists who participate in our work. Some members of this staff have to combine their duties as laboratory technicians with those of crew of the *Odalisca*, the establishment's 60-foot research vessel.

The primary aim is to study the factors which influence the fate of radioactive substances in the sea and to assess with accuracy the extent to which they could become hazardous to man, either directly, or indirectly, by finding their way through the marine "food chain" into the fish which form part of our diet.

Fig. 2 is a schematic representation of the various food chains possible in the marine environment and of how they might affect the fishing products utilised by man. But let this simple drawing not give us the wrong impression, suggesting that these relationships are known and understood. A large amount of basic research is still to be carried out. This is why the laboratory is engaged primarily in a programme of basic research calling for the combined skills of chemists, botanists, zoologists, microbiolo-

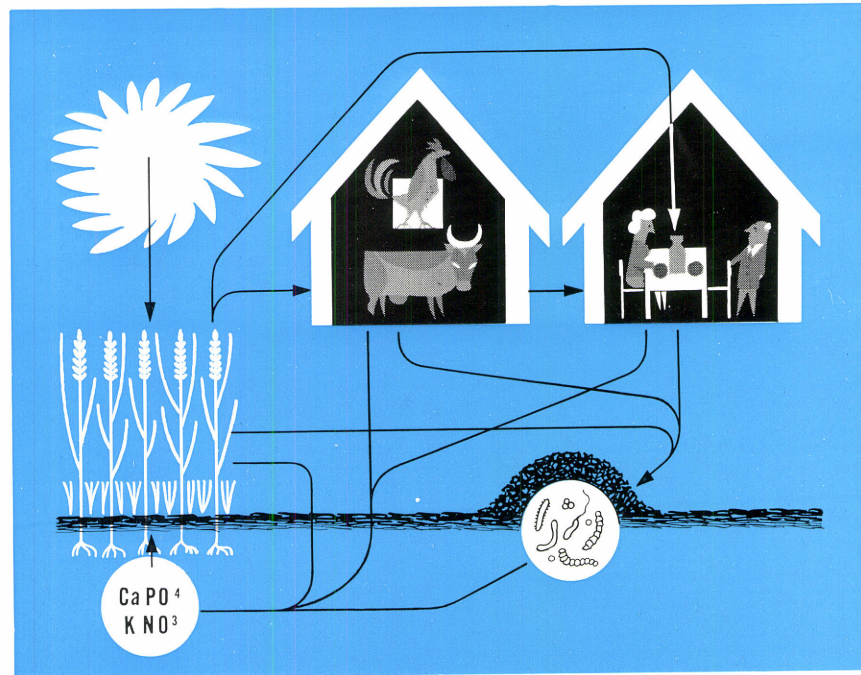
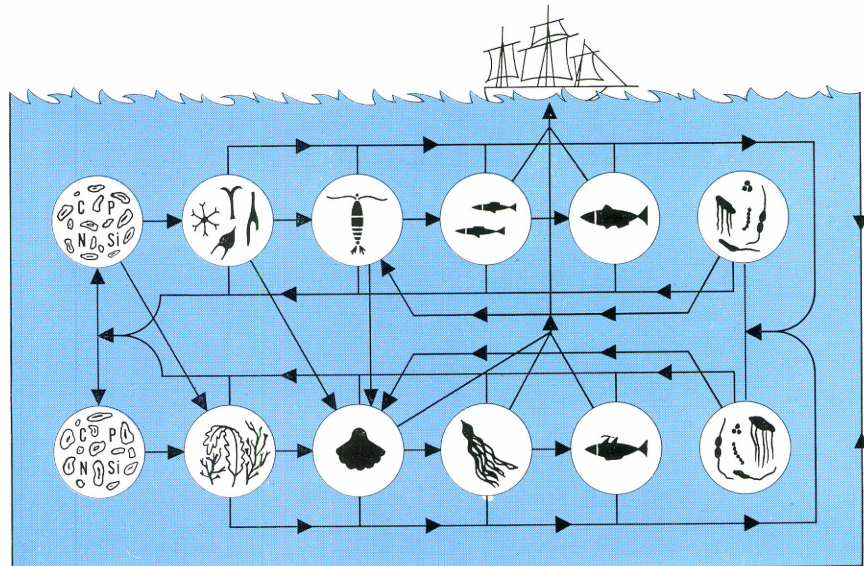

Figure 1: Man's agricultural food chain

Uptake  
↓  
Mineralisation ← Decomposition

Figure 2: The various food chains in the marine environment





The Fiascherino laboratory's research vessel  
Odalisca

Sampling at sea . . .

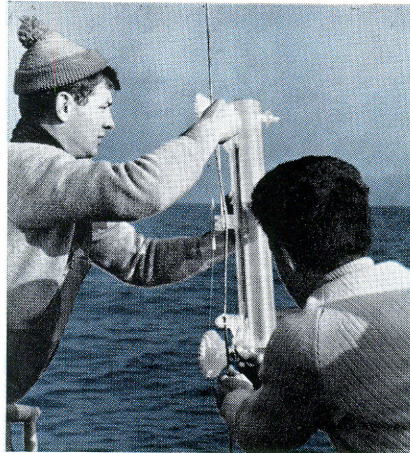

. . . and research in the laboratory



gists and, last but not least, instrument-engineers responsible for the development of the very specialised oceanographic equipment which is needed.

Its activities are split into two areas of research.

The first is the *descriptive* analytical part, which includes an investigation of the sea water itself and measurements of radioactivity. It also involves making an inventory of the most abundant (and therefore probably most important) marine organisms, studying their distribution and determining the environmental factors most likely to affect them.

For this purpose, a well-defined "slice" of the Mediterranean Sea off the locality called *Cinque Terre* was chosen, with an area of about  $30 \times 30$  km and a depth ranging from 0 to 500 m. The reason for this restriction was that it was thought preferable to investigate a fairly small zone thoroughly, in order to have a complete set of data ready for comparison when sampling is extended to bigger areas, in 1965 to the Ligurian Sea and later to even larger parts of the Mediterranean.

The second is the *experimental* analytical part, which deals with the actual influence of environmental factors on the growth and metabolisms of marine organisms, and their capacity to absorb, accumulate and transfer radioisotopes. Experiments will be carried out both in the laboratory and in nature. In order to obtain facts and figures about the conversion of inorganic into organic material and the transfer of radioisotopes by organisms, the *chemistry group* is analysing the inorganic nutrient substances (nitrates, phosphates, etc.) present in the sea water and the organic matter produced from them.



Special emphasis is laid on certain elements such as zinc, cobalt and copper. As they are known to be present in marine organisms at very high concentrations (1,000 to 10,000 times higher than in sea water), the addition of even small quantities of their radioisotopes to the environment will result in a high degree of radioactivity. These elements are as it were the counterparts in the sea of those, such as strontium and caesium, which are considered as the most dangerous on land.

The *botany group* concerns itself with the actual process through which marine plants assimilate inorganic material and transform it into organic matter. It is of basic importance because it is the first link in the marine "food chain" and thus may be primarily responsible for the introduction into it of radioisotopes. "Phytoplank-

ton", for instance, (small unicellular plants floating in the sea) and algae are eaten directly either by "zooplankton" (small marine animals) or by fish.

The *zoology group* deals mainly with plankton organisms, especially copepods, which feed on marine plants and in their turn serve as the main food source for fish. It follows that they have an important part to play in transferring radioelements into the fish caught by the fisherman's nets.

In order to establish the quantities involved in metabolic processes, laboratory methods using radioisotopes as tracers have been developed. To make efficient use of them, however, the organisms have to be reared and bred in the laboratory. This has been done successfully with algae, but in the case of zooplankton organisms, greater difficulties were encountered. Nevertheless they were eventually overcome and a suitable

technique was recently found for the culture of an open sea copepod species *Euterpina acutifrons*.

Bacteria, which on land perform the vital role of decomposing organic substances, can also be found in large numbers in the sea. Their function in the sea is however still imperfectly known and is being investigated by the *microbiology group*.

The four scientific groups of the laboratory would be unable to make any progress without adequate measuring instruments. As much of the equipment they need is not available commercially, it has been necessary to form a fifth group, directly responsible for the *development of oceanographic equipment*. One of the first achievements of this group has been the development of a basic unit for the research ship *Odalisca*, which indicates depth, temperature and water-flow. The information is transmitted aboard by an ultrasonic device.

A word should be said about the links between the Fiascherino laboratory and Euratom. The Euratom Treaty lays down the study of the harmful effects of radiation on living organisms as one of the essential tasks of the European Atomic Energy Community in the field of biology. A study of this kind necessarily includes an investigation of the movements of radioisotopes in the biosphere, since intelligence about the movements of the "enemy" is of fundamental importance to strategy.

In 1963, Euratom concluded an association with the CNEN's Fiascherino laboratory in order to add a needful complement to projects already under way on the movement of radioisotopes in media other than the sea. The information secured in Fiascherino will thus be readily available to the whole European Community.

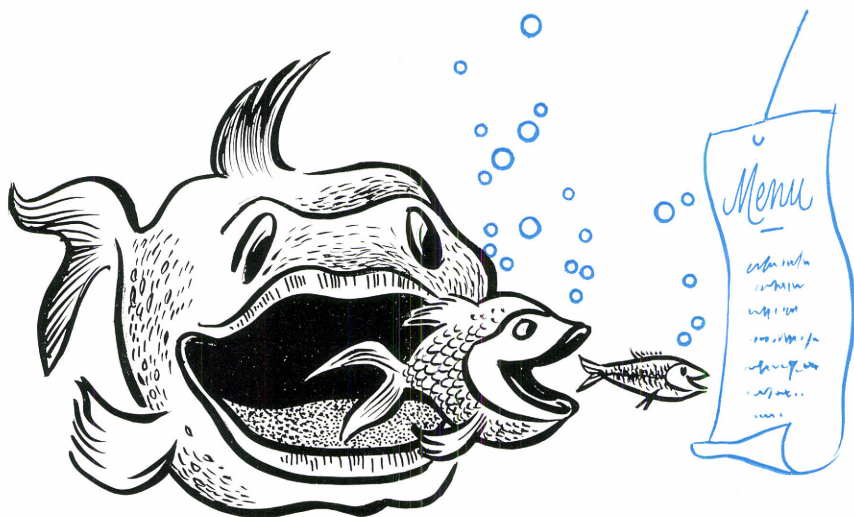

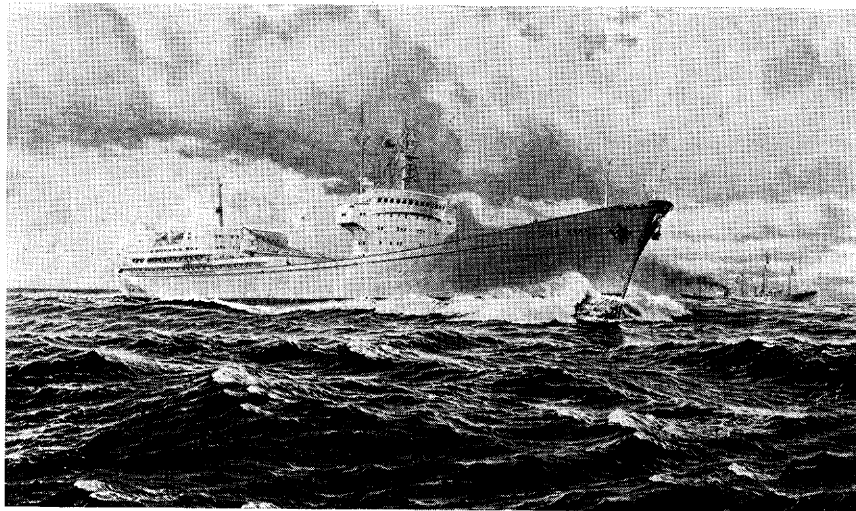

EUBU 4-3

# Nuclear Merchant Ships

WOLFGANG ROJAHN, *Directorate-General for Industry and Economy, Euratom*

It has been clear for some years now that nuclear propulsion for submarines, aircraft-carriers and other special-purpose ships is superior to conventional drive units such as Diesel engines or steam boilers and turbines: this superiority is mainly based on the fact that nuclear reactors

- can run for several years without the nuclear fuel being "topped up" or replaced;
- run on nuclear fuel the weight and volume of which is so small compared with conventional fuel that nuclear ships can be built for a higher useful load than conventional ships of the same deadweight tonnage;

- are ideal for powering submarines, since no oxygen supply is required, thus enabling the craft to remain submerged for very long periods.

The present state of affairs in the development of nuclear energy indicates, moreover, that marine reactors can be built which, although not taking up any more room, permit greater power and hence greater cruising speeds than steam-turbines or Diesels.

Finally, on the basis of the experience gained with atomic power plants it is likely that with further technical advances the automation of nuclear propulsion units can be brought to such a point that smaller crews may perhaps be required.

These advantages afforded by nuclear propulsion, permitting significant improve-

ments in the operational efficiency of sea-going vessels, are reason enough for the considerable efforts which are being made on theoretical and experimental research and design work in an attempt to develop economic nuclear propulsion units for merchant ships.

Since 1961 Euratom has been participating in these development activities partly by assigning its own experts to such projects, partly by acting as a clearing-house for the exchange of information, both within the Community itself and with non-member countries, and also by financial support. Euratom's contribution to individual projects and the rights which it thereby acquires, particularly with regard to the dissemination of information within the Community, are laid down in contracts, which have proved extremely successful as a means of avoiding duplication of effort. When, in 1960, Euratom decided to include marine reactor projects in its programme, it was obvious that such a long-term and costly undertaking could only be successful if subsidised by public funds and that considerable savings could be made by Community level co-ordination. It was found that the proposed development work in the Community could be dovetailed into one harmonious programme.

At the present moment, the programme is made up basically of these interlocking parts:

- planning, construction and operation of the nuclear merchant ship *Otto Hahn*, the keel of which was laid in September 1963 and which was launched in June 1964, after results of previous studies had shown that a reactor propulsion unit must undergo shipboard trials in order to provide a basis for future development;

- theoretical and experimental research and, on the basis of the results obtained, together with the knowhow gained with *Otto Hahn*, the drawing up of construction plans for economic nuclear-powered merchant ships;

- development work of general importance for nuclear shipping, such as weight- and space-saving radiation shielding, reinforcement of the hull in order to protect the reactor unit in the event of collision, and mechanical resistance of the reactor unit to the motion of the ship.

## The research ship "Otto Hahn"

Under the contract of participation in the *Otto Hahn* research ship project concluded between the Community and the *Gesellschaft für Kernenergieverwertung in Schiffbau und Schifffahrt mbH*, Hamburg, at the end of July 1964, Euratom is to provide funds totalling four million EMA u.a.<sup>1</sup> up to the

1. 1 EMA u.a. = 1 US Dollar

middle of 1968. In return for this financial support, for its collaboration, and for the provision of information, the Community has acquired certain rights relating, in particular, to the dissemination of the know-how obtained in the design, construction and operation of the vessel. Furthermore, the contract contains stipulations governing the submission of tenders for and the supply of components for the reactor unit, which guarantee identical terms for firms in all the Community countries.

The ship, which is being built by the *Kieler Howaldtswerke AG*, is designed in line with the classification rules of the *Germanischer Lloyd* and *Bureau Veritas* in such a way that it can be used both for research and development work as well as serving as a bulk cargo ship.

The *Deutsche Babcock & Wilcox-Dampfkessel Werke AG* and *Interatom (Internationale Atomreaktorbau GmbH)* group have been commissioned to supply the reactor unit. The main criteria governing the selection of the type of ship and its size, as well as the power level and design of the reactor unit were that a very high degree of safety should be ensured, that it should be possible to carry through a comprehensive research

programme and that the construction and operating costs should not exceed the amount strictly required to obtain adequate data to orient future development.

### Type and size of "Otto Hahn"

After examination of bids for tankers, bulk cargo vessels and passenger ships, the choice finally fell upon an ore-carrier, whereby a decisive role was played by the consideration that a ship of this type can be well-equipped to withstand accidents, especially collisions and stranding, for relatively small extra costs, and that the fire hazard is insignificant.

During the trial voyages the numerous ballast tanks common in ore-carriers held such large quantities of sea-water that the same draft was obtained as with a full ore-cargo of 15,000 tonnes. A displacement of about 26,000 tonnes, approximately 10,000 shaft horsepower and a speed of 16 knots, which were designed in order to keep costs down, are sufficient to provide operating data which can be applied to larger and faster atomic ships built for economic operation.

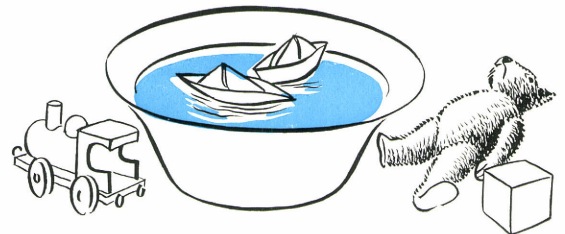

The *Otto Hahn*, which is about 172 m long and about 24 m in the beam, is large enough for the fuel-handling unit to be housed on board. This gear consists mainly of a 35 tonne crane, a transportation container (for radioactive reactor parts) and a water tank, 8 m deep and lined with concrete walls, to hold a complete set of spent fuel elements together with other parts of the reactor unit and the transportation container itself. Moreover, there is enough space in a long superstructure at the after end of the ship to accommodate a scientific staff of about 40, which the vessel is to carry in addition to its crew of about 70. This also includes personnel undergoing training on board. Six passenger cabins are provided on the boat-deck, while for physics, chemistry and mechanics, laboratories are placed on the main deck, above the reactor.

The *Otto Hahn* after launching in June 1964, Kiel

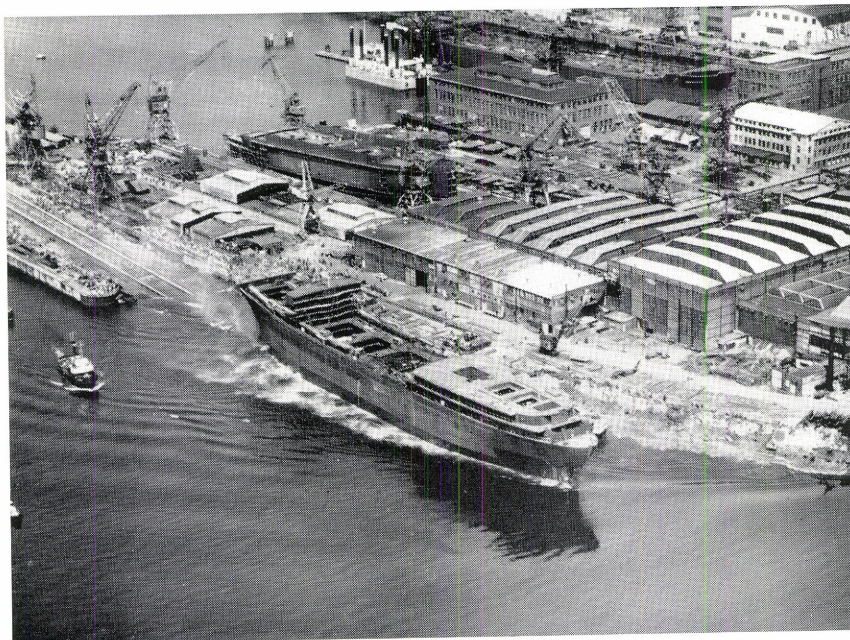

### Measures for improving safety

Whereas the first nuclear reactors were built in sparsely populated areas and were not allowed in the vicinity of residential areas and industrial zones until sufficient experience had been acquired on their safety aspects, even the first nuclear ships must have access to busy ports without jeopardising their environment and those on board in the event of accidents. The shipbuilders' task is therefore to develop new and safe designs, the reliability of which will, it is hoped, not be put to the test in actual accidents but which can be tried out on models.

The special bridge in the bows of *Otto Hahn*, which is no longer customary even in big tankers, is designed as an additional safeguard. In the same way as the superstructure aft, this contains a fully-equipped steering position, fitted with separate

lines, with particularly good visibility for conning purposes. Since this bridge is situated above the auxiliary engine-room, the ship's main functions can continue to be performed even if the entire after section becomes inaccessible as the result of an accident.

A number of safeguards are provided to ensure the vessel's stability in the event of flooding due to leaks. An inner shell is fitted at a distance of about 2-2.5 m inside the outer skin and contains 14 watertight compartments: 6 ore-holds (A), the auxiliary boiler-room (B), the main engine-room (C), the reactor compartment (D), ancillary reactor equipment (E), the cooling pond for radioactive reactor parts (F), the auxiliary engine-room (G) and, finally, two other water-tight compartments in the after and fore peaks (H). The side-tanks mounted between the outer and inner shell are

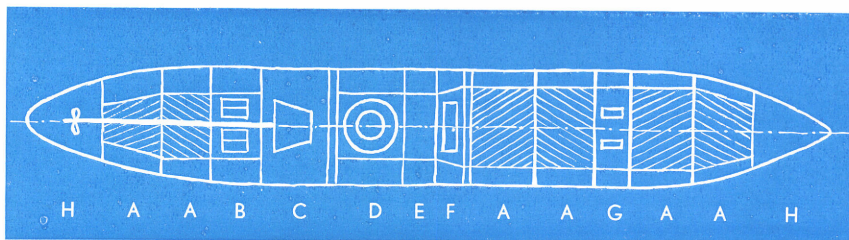

compartmented more than is usual and are connected up by compensating pipes running athwartships, so that a list can be corrected in the event of a leak.

This subdivision ensures that the ship can still be navigated and that there is no possible risk of her sinking even if three compartments are flooded with sea-water. On each side of the nuclear plant there are two decks, extending to the outer skin, and three narrower decks supported by web frames. In the event of collision these

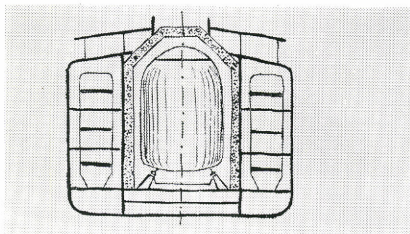

reinforcements are intended to absorb the impact energy by plastic deformation and to tear open or flatten the stem of the striking ship. The side-tanks installed in this area are not filled with seawater even when the ship is in ballast, in order not to impair collision safety. In addition, the 50 cm thick reinforced concrete walls fitted as radiation shielding on the reactor compartment bulkheads prevent the striking ship from penetrating as far as the reactor containment shell. The possibility of damage to the pressure vessel inside, which is enclosed in steel, cast iron and lead radiation-shielding plates and which constitutes the first barrier against the escape of radioactive substances, can be ruled out. In connexion with collision safeguards, mention should also be made of the fact that important components are mounted amidships and the piping is in loop form, while the auxiliary engines and the corresponding stand-bys are not arranged directly alongside each other but are mounted separately on different sides of the central section of the ship.

Protection against stranding is provided by two inner bottoms which are located underneath the reactor and are 1.5 and 2.5 m above the outer bottom respectively. The upper bottom, which supports the reactor containment shell, is specially reinforced. The 1 m high space beneath it can be filled with sea-water as an additional radiation barrier when work has to be carried out in dock on the outer bottom, for instance. The raising of the double bottom below the holds to 3.5 m, bringing about a slightly higher centre of gravity, which is relatively low on ore-carriers, affords further protection against stranding.

Although the high degree of compartmentation makes it extremely unlikely that the ship will founder, precautions have also been taken for this extreme eventuality. In order to prevent it becoming distorted and springing leaks as a result of the external sea-water pressure, the reactor containment shell is fitted with valves which burst open at a depth of 20-30 m, allow the sea-water to flow in and then close again by a spring-loaded device as soon as the pressure has been equalised.

In the event of reactor malfunctions, the high-pressure and low-pressure steam turbine and the other steam consumers can be supplied from two auxiliary boilers. With them, a speed of 8.5 knots can be



maintained and the oil supply will hold out for about 2,500 nautical miles. In order to prevent corrosion in the reactor unit, high purity feed-water is used and special precautions have been taken against flooding by sea-water.

A further safety precaution is the demarcation of the reactor zone by after and forward cofferdams each 1.6 m long. The longitudinal strength of the ship was increased by fitting the main deck and outer bottom with longitudinal frames. In addition, the moulded depth is particularly high in relation to the draft and length of the ship. The emplacement of the reactor containment shell on the upper inner bottom and the attachment of the concrete radiation-shielding slabs to the bulkheads of the reactor compartment are carried out in such a way as to ensure the continuous distribution of the hull's resistance to bending stresses over its length.

Since the safety precautions which were outlined above, not to mention those also applied to the turbine plant, the steering gear, the auxiliaries and the electrical equipment, entail considerable expense and detract from the profitability of nuclear merchant ships, an attempt will have to be made during the operation of *Otto Hahn* at sea to determine what modifications can be introduced to simplify the design and cut costs.

### The reactor unit in the "Otto Hahn"

In 1962, when the decision was taken to conduct trials on a ship-borne reactor, the pressurised-water type was the only one contemplated. At that time investigations into the suitability of other types for marine propulsion, such as boiling-water, gas- or organic-liquid-cooled reactors, had not yet reached a stage sufficiently advanced for construction to be initiated immediately in the Community and safe operation at sea ensured.

In company with all light-water reactors, the pressurised-water unit in the *Otto Hahn* is based on development work carried out in the United States and in particular on preliminary designs drawn up by the American firm of *Babcock & Wilcox* with USAEC backing, after completion of the construction plans of the reactor unit for the world's first nuclear-powered cargo and passenger ship, the *NS Savannah*. In drawing up the

tenders for the *Otto Hahn*, however, the *Deutsche Babcock & Wilcox Dampfkesselwerke AG* and *Interatom (Internationale Atomreaktorbau GmbH)* arrived at new variants on the American theme and devised improvements of their own. Despite the risks attendant on a prototype reactor design, these concerns agreed on a firm price for the supply of the unit and undertook to provide guarantees covering the delivery date and operability of the plant, the components of which are of exclusively European origin.

In the drawing up of the construction plans the possibilities for effecting reductions in weight, size and costs offered by the design used were only exploited to the extent that the reactor's suitability for research and development was not impaired. In the further development by the above-mentioned companies of the reactor type

selected for the *Otto Hahn*, however, the chief criterion adopted will be profitability. In the pressurised-water reactors built hitherto, the pressure vessel (in which the core is mounted and the primary water heated) and the steam generator (in which secondary steam is generated by the primary water in a separate piping system leading to the turbine) were installed separately and connected by pipelines:

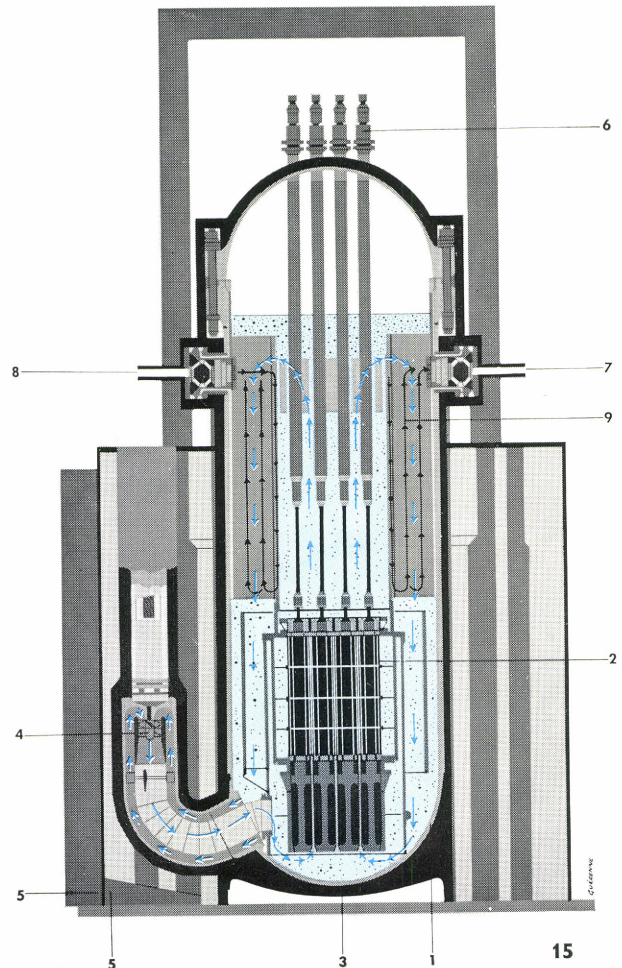
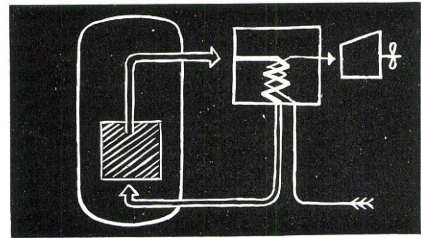

Diagrammatic cross-section of the *Otto Hahn's* pressure vessel

1. pressure vessel
2. core
3. insulation
4. primary circulation pump
5. shielding
6. control rod drive mechanism
7. steam outlet
8. feed-water inlet
9. steam generator

N.B. The primary circuit is coloured, the secondary circuit black.

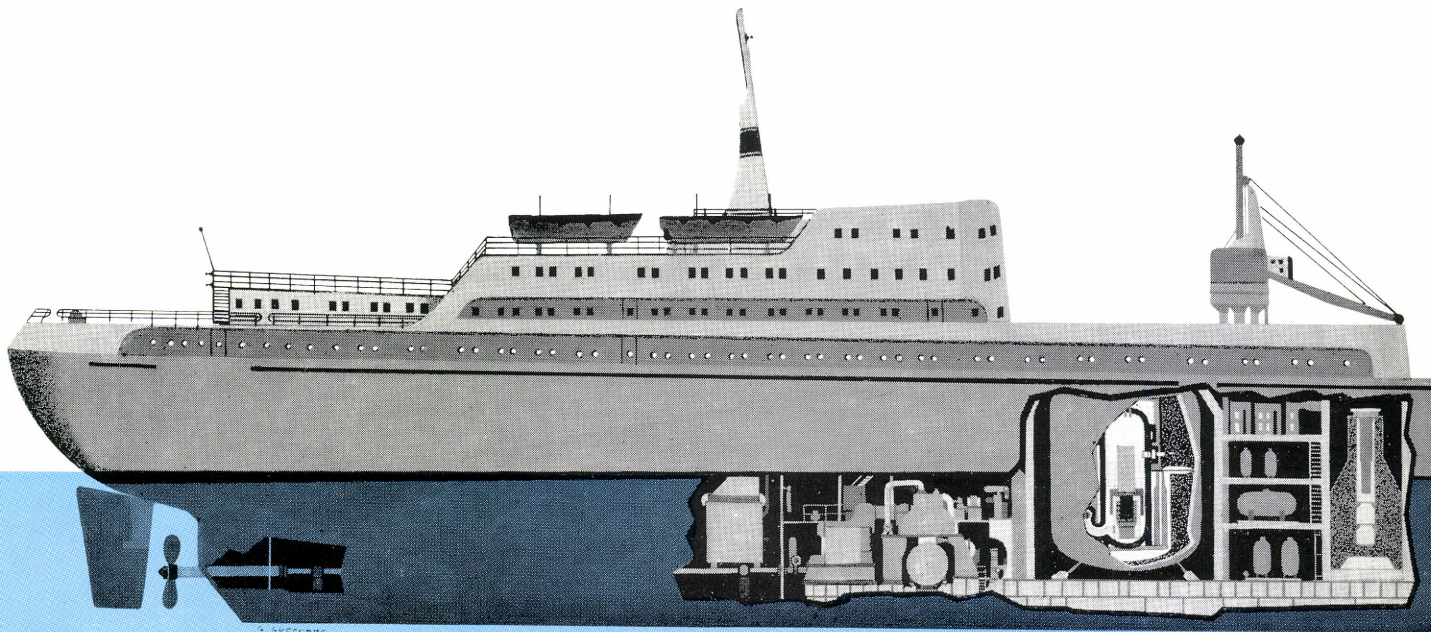

In the *Otto Hahn* reactor, however, the cylindrical steam generator is fitted inside the pressure vessel above the core:

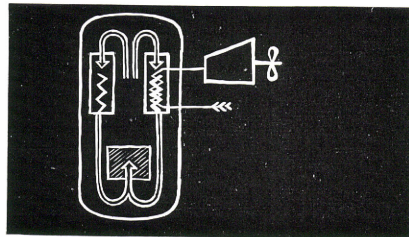

In addition, three primary water circulation pumps are arranged laterally in the immediate vicinity of the lower half of the pressure vessel. In this way, the dimensions of the entire primary unit are cut down considerably and substantial savings in weight effected, since the radiation-shielding plates of heavy steel, cast iron and lead enclosing the pressure vessel (2.63 m in diameter and 8.57 m high) and primary pumps can be made smaller. The primary pipelines required if the pressure vessel and steam generator are mounted as separate units may be dispensed with; this too results in less weight and, besides, makes it possible to avoid pressure drops,

so that an output of only 20 kW per primary pump is adequate.

The primary water is pumped at a rate of 2370 tonnes per hour into the space below the core, from where it flows between the heat-generating fuel elements and up above the core to the water surface (see Fig. p. 15). From here it first streams radially outwards, and then down between the steam generator tubes to the bottom of the pressure vessel and back again to the pumps.

As it flows downwards, the primary water is cooled from 278 to 267°C. On the other hand, the secondary water is pumped into the upper part of the steam generator via three inlet nozzles in the wall of the pressure vessel and leaves it again at about the same height in the form of steam (64.6 t/h) via three outlet nozzles, after having first passed straight down the inner wall of the steam generator in three separate pipe systems and then forced up again through helical tubes. It therefore flows here in the opposite direction to the primary water, which runs downwards on the outside of the tubes. The characteristics of the secondary steam passed to the turbine are: pressure 31 kg/cm<sup>2</sup>, temperature 273°C with 36°C superheat.

The first core contains twelve square and four triangular fuel-elements consisting of a

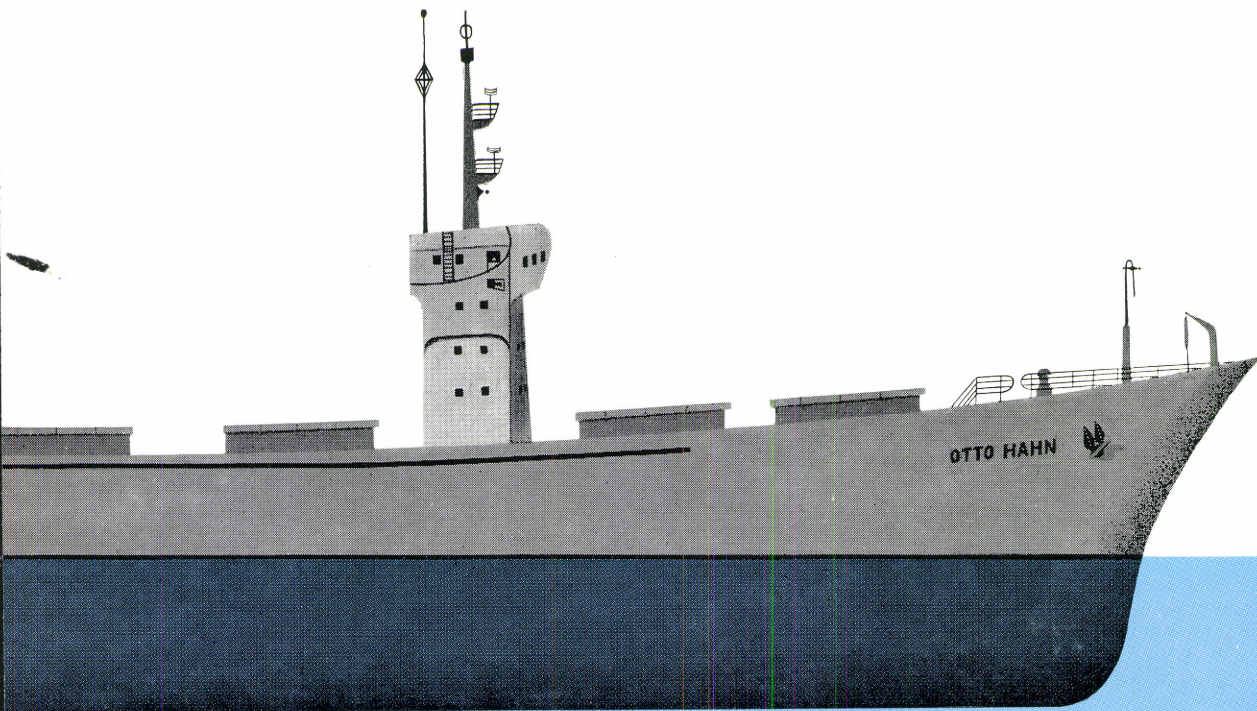

total of 3128 fuel rods, which are made of stainless steel filled with slightly-enriched

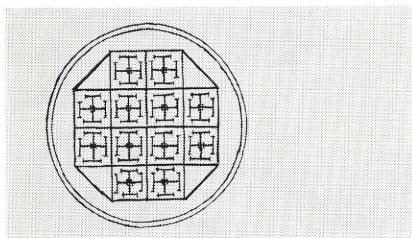

uranium dioxide (four zones with an average enrichment of 3.6%) in pellet form. With a fuel charge of three tonnes of uranium the first core is scheduled, without exhausting its full potential, to run at full load for only 500 days, with a thermal power of 38 MW, since this lifetime is regarded as adequate for trials and a second, improved core is subsequently to be tested. At the temperature of 278°C above the core the pressure of about 63 kg/cm<sup>2</sup> in the pressure vessel corresponds roughly to saturation pressure. In this way a steam space can form in the upper part of the pressure vessel so that pressure is maintained during load fluctuations. A special pressuriser unit, such as those required in existing pressurised-water reactors, design-

ed for a higher primary pressure, is therefore not necessary. Owing to this low primary pressure, a wall thickness of 5 cm is sufficient for the cylindrical section of the pressure vessel, which is made of special steel and is plated inside to prevent corrosion.

On account of these and other features the reactor is highly suitable for a test programme aimed at improving and simplifying such power units.

#### The "Otto Hahn" test programme

The main tests listed below, the details of which are not yet fixed, are to be carried out on board in order to determine the actual effects of the motion and vibration of the ship in various conditions at sea.

1. Valuable pointers for further development work should be obtained from tests aimed at determining whether any advantages are to be gained by the use of boiling-water reactors for marine propulsion. While the development work in which Euratom is participating is at present focussed on the pressurised-water reactor, new data might of course show whether the path chosen does in fact offer the best prospects. Slight

primary water boiling occurs in the upper part of the core in the *Otto Hahn* reactor in normal operation, and it increases when tests are conducted at reduced primary pressure, so that some approximation to the conditions of a boiling-water reactor is achieved. Operating tests under such conditions might therefore be expected to provide some indication as to the behaviour of boiling-water reactors.

2. When the reactor load is stepped up, e.g. owing to the ship's speed being increased, the heat extraction from the reactor rises, the core temperature drops and the primary water holds less steam bubbles. As a result the amount of heat generated by the nuclear fission increases, since at falling temperature the reactivity of the fuel rises and at increasing density the moderating effect of the primary steam/water mixture is stepped up. When power is reduced the process is reversed. Tests are to be carried out to determine the extent to which the reactor's energy generation follows load fluctuations in this self-regulating way, or the extent to which the existing control system could possibly be simplified.

3. The heating of the primary water in the reactor core causes a natural upward

flow, i.e. in the same direction as that in which the water is pumped. Since the pressure losses are slight, owing to the fact that the steam-generator is housed in the pressure vessel itself, the reactor can be operated on partial load when the pumps are cut out, i.e. by natural circulation. Tests are to be conducted to determine the power level up to which natural circulation is sufficient.

4. The ship-borne fuel loading/unloading unit also facilitates the exchange of other reactor parts for testing improvements. As was mentioned above, the first core is to be exchanged after only 500 days' full-load operation. Variations of other reactor components, such as the control rod drive system, are also to be tried out.

5. The reactor's auxiliary equipment includes, for example, a steam bleeder system for excessive vessel pressure, the primary water clean-up installation, the containment shell ventilation unit and the fresh-air supply to all the compartments in the reactor zone. These last-named are kept at under-pressure in relation to the adjacent ship's compartments and to the atmosphere, so that uncontrolled air movements can occur only from outside to inside. The radioactivity in the air passed out of the reactor zone is to be monitored constantly. Numerous tests are planned in an attempt to cut down the cost, weight and size of these installations.

6. The entire ship is monitored by radiation counters, not only on safety grounds but also in order to improve radiation shielding devices. In this connection mention should be made of the fact that the primary unit shielding is so effective that the inside of the containment shell can be entered for brief periods via a spherical lock during operation. This was done to facilitate research work, despite the resultant increase in weight and space.

7. Other equipment is to be used for research in ship-building and operating. For example, detailed investigations are to be carried out on the strength of the ship and also on her propulsion characteristics.

In conclusion, the *Otto Hahn* can be described as a floating laboratory and no expense has been spared to enable new information to be acquired.

### Construction plans for economic nuclear merchant ships

Since 1961 Euratom has been participating under contracts of association in development projects which are being carried out on the one hand by the *Reactor Centrum Nederland (RCN)* and on the other, with the support of the *Italian Atomic Energy Commission (CNEN)*, by *Fiat*, acting as the reactor construction firm, and *Ansaldo*, acting as the shipbuilder. Although the programmes of both these contracts have the same aim at present, i.e. the drawing up of construction plans for economic marine-type pressurised-water reactors, the individual technical designs involved are all so different that the current experimental and theoretical studies do not overlap. The draft designs elaborated under each programme are constantly being improved in line with the latest research results.

This work will probably not be completed, and the final construction plans drawn up, until at least some of the results of major experiments carried out with the *Otto Hahn* are available and can be taken into account.

### Extending the life of a reactor core charge

An example of different technical designs fulfilling the same purpose is provided by methods for prolonging the life of a reactor core charge. These involve the insertion into the core, in addition to the control rods, of neutron-absorbers, by means of which it is possible to offset a very high excess reactivity in a new core. This compensating effect must decrease during operation in proportion to the core reactivity drop brought about by the formation of fission products. In the *Otto Hahn* reactor some fuel rods are replaced by rods filled with boron-containing material, the neutron-absorbent properties of which decline during operation, and which is thus called "burnable neutron poison". Improved techniques for achieving a more uniform neutron-flux distribution are now being developed. *Fiat* is conducting investigations to determine whether liquid neutron poi-

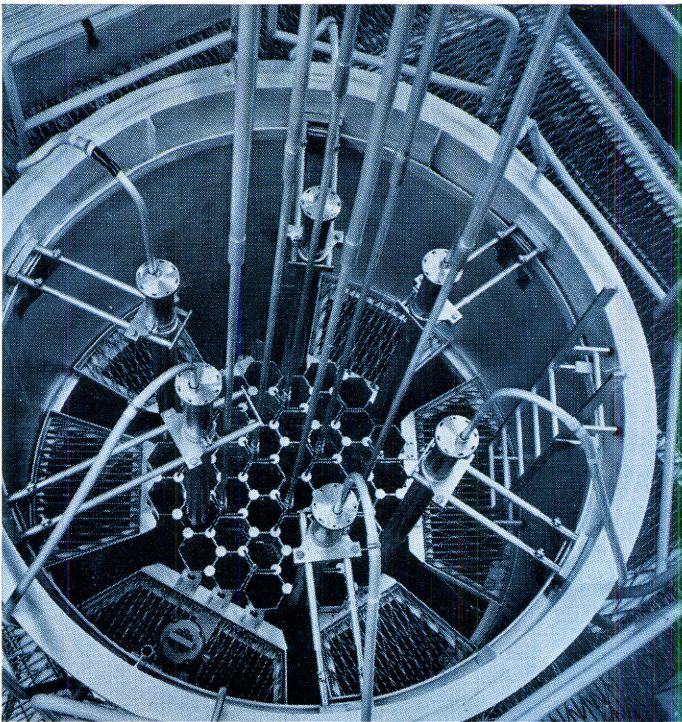

The Petten installation Krito for core simulation

son dissolved in the primary water can be used in a marine reactor. The RCN is attempting to mix poison with the uranium dioxide fuel in the form of solid particles.

### Saving weight and space

The desire to save weight and space on the one hand and on the other to make for easy maintenance and repairs has likewise resulted in the examination of a variety of solutions, the choice of which will also be influenced by the construction cost factor. Under the RCN project, there are two steam-generators which are not, as in the *Otto Hahn* reactor, to be "integrated" in the pressure vessel but installed alongside the pressure vessel, each forming one single unit with a primary pump, for reasons of accessibility. *Fiat* and *Ansaldo* have, however, devoted particular attention to a so-called "compact" design, in which the steam-generators are mounted right next to the pressure vessel, and are examining the advantages of this type of construction in comparison with the fully integrated design. Interest is also being shown in different primary circuit designs, the main purpose of which is to achieve a high power density in the core. Dual flow in the core is envisaged under the Italian project. The primary water flows under the pressure generated by pumps from top to bottom in the outer

core zone and from bottom to top in the inner zone. The fuel in both zones is enriched to varying degrees with fissile uranium-235:

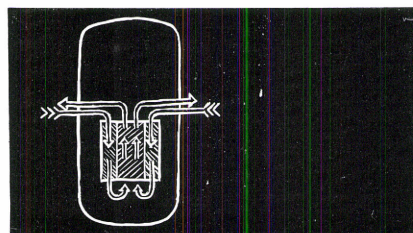

Under the Dutch project, which also has a two-zone core, the water flows through the core in only one direction, but only some of the heated primary water is passed to the steam-generator, the remainder being recycled to the core:

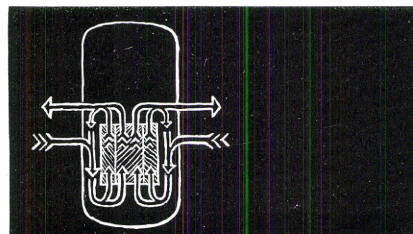

As can be seen from the remarks below, the two programmes are also complementary in the sense that various fields are mainly studied in Italy and others in the Netherlands.

### Special aspects of the Italian programme

Before Euratom and its Italian partners agreed in May 1963 that a pressurised-water reactor fitted with primary water pumps ensuring forced circulation in the primary circuit should be taken as the basis for further development work, a comparative study was undertaken of pressurised and boiling-water reactors with both forced and natural circulation. In addition, tests were conducted to determine the feasibility of a boiling-water reactor without steam generator, i.e. with a direct reactor-to-turbine cycle. This study provided an insight into the basic assets and drawbacks of the various types and revealed that the research and development work necessary to adapt the forced-circulation pressurised-water reactor for marine uses involves considerably lower costs than the other types of water reactors.

With the collaboration of the *Ansaldo* shipbuilding firm, particularly detailed studies are also being carried out under the Italian contract on naval constructional features aiming at the optimum operation of the nuclear propulsion unit. The dovetailing of shipbuilding and reactor technology results in the emergence of new perspectives which are of decisive importance to further developments. The shape of nuclear tankers, for instance, is to be designed in such a way that the ship can travel at the high speed

corresponding to full reactor power when unladen, i.e. when she is high in the water, for a reduction in reactor power does not result in appreciable fuel savings, as in conventional ships.

#### **Special aspects of the Netherlands programme**

The Dutch programme lays special stress on experimental tests yielding results which may lead to the improvement of existing computation processes and the develop-

ment of reactor construction materials at a pressure of 140 kg/cm<sup>2</sup> and a temperature of 300°C, together with an installation for examining complete fuel elements under irradiation at 325°C and a pressure of 140 kg/cm<sup>2</sup> in the Petten high-flux reactor. Furthermore, thermodynamic and hydrodynamic test installations have been installed in the laboratories of the Eindhoven and Delft technical universities. An installation now under construction at Eindhoven is to be used for studying heat transfer from a primary to a secondary circuit. The model of a steam-generator with superheater to be employed for these experiments will have a

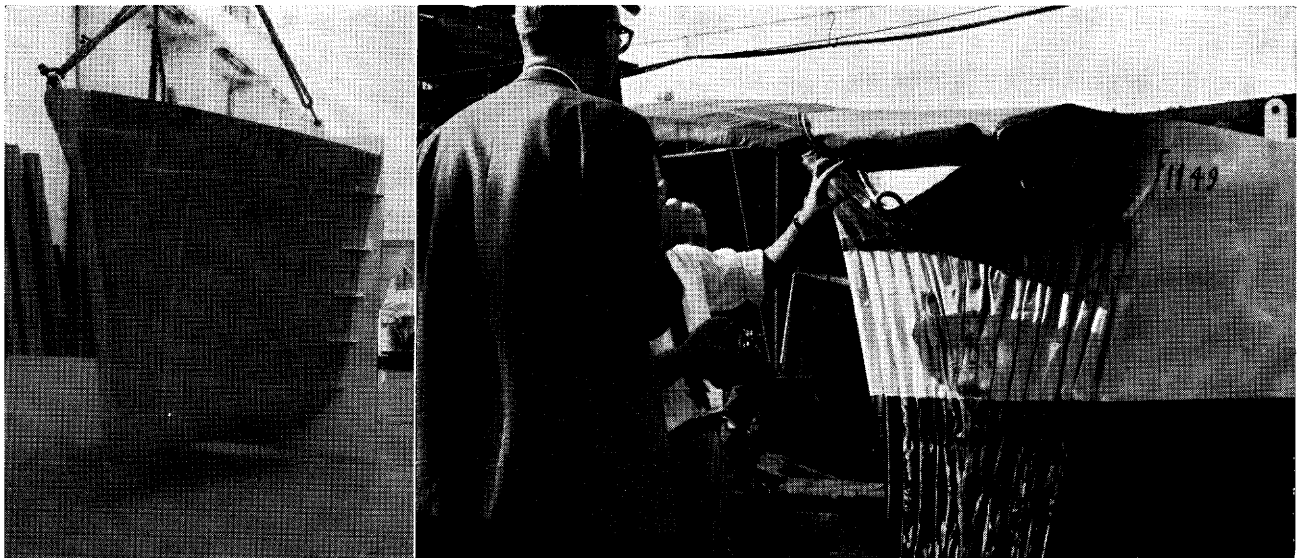

*Model tests on collision barriers. Left: a model of the striking ship before collision.*

*Right: after the collision, the model of the striking ship has been crushed flat by the collision barrier of the struck vessel.*

ment of new ones. With Euratom's support, two assemblies have been built at the Petten research centre, in which reactor cores can be simulated and physical measurements carried out, in particular, of the neutron flux distribution with various fuel element geometries and control rod and neutron poison arrangements. In the one assembly the nuclear fission processes are allowed to proceed until a chain reaction is maintained (critical experiment), while the other assembly operates in the sub-critical range.

At the Petten centre there has also been set up a loop for testing the corrosion resist-

heat transfer power of about 6 MW. On completion of the work for the Dutch marine reactor project, it will be possible to place the unit at the disposal of other interested parties in the Community.

#### **Development work of general importance for nuclear-powered merchant ships**

The Euratom programme would be incomplete if it were confined to participation in individual reactor projects. As was to be

expected, Euratom's co-ordination work slashed costs particularly in those fields involving problems common to all marine reactors and which call for expensive testing and wide-ranging theoretical studies, especially since in the latter case account must be taken of the cost of computers. The contracts concluded between Euratom and the RCN and the Italian firms of Fiat and Ansaldo cover, besides the work already mentioned, such fields as research into radiation shielding and model tests aimed at the development of protective structures against collision at sea. Furthermore, in addition to the contract providing for its participation in the *Otto Hahn* project, Euratom concluded an agreement with the *Gesellschaft für Kernenergieverwertung in Schiffbau und Schifffahrt GmbH (GKSS)* back in 1961, for a provisional period of five years, covering the optimisation of radiation shielding and tests on the mechanical strength of reactor components.

### The optimisation of radiation shielding

In marine reactors it is essential to avoid making the radiation shielding bigger than is absolutely required for safety. For this purpose it is indispensable to have precise data on the degree to which the reactor's radiation, consisting largely of neutrons and gamma-rays, is attenuated on passing through "opaque" materials. Since water, owing to its hydrogen content of low atomic weight, is particularly suitable as neutron shielding, while metals such as iron and lead, owing to their high atomic weight, absorb gamma-rays, radiation shields can be made of metal plates with layers of water between them.

The GKSS swimming-pool research reactor at Geesthacht near Hamburg, which with its two cores can produce a thermal power of 5 MW, is fitted with devices for the measuring of the radiation absorbed in small ( $60 \times 60 \text{ cm}^2$ ) and large plates ( $2 \times 2.5 \text{ m}^2$ ). Since the smaller plates, which are made of various materials and can be used in different thicknesses, are cheaper, they are suitable for preliminary tests in which particularly effective combinations of plates and water-filled spaces can be selected. In order to improve the measuring accuracy the reactor radiation is first converted into

parallel beams (collimated) and directed through an opening at a test shield, the total thickness of which can amount to 60 cm:

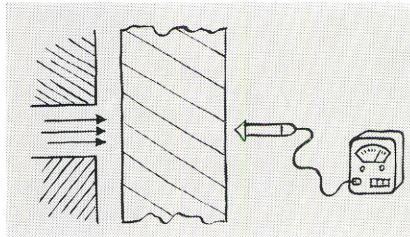

For thicker shields of up to 120 cm and to obtain accurate measurements (in which all the secondary radiations and phenomena stemming from the irradiated substances can be picked up), the larger plates are used. They are set up near the reactor core in a cradle which can be placed into one of the reactor's swimming-pools by a crane. In addition, the Geesthacht reactor is fitted with an aluminium-lined tunnel extending into another of the three swimming-pools. A trolley carrying shielding plates can be driven into the tunnel to the vicinity of the reactor core situated in the adjacent pool. The tunnel can be filled with either gas or any liquids required.

*The rolling-rig in Geesthacht for testing the mechanical strength of reactor components.*

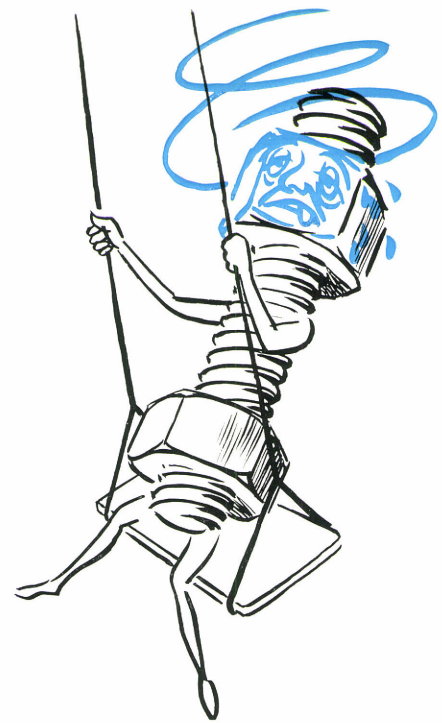
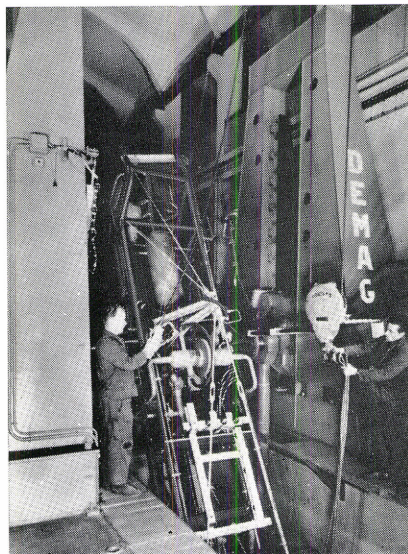

The measurements carried out with these units were supplemented by experiments with the swimming-pool research reactor owned by the Sorin company at Saluggia, near Turin, which is being used under the Fiat-Ansaldo contract. This work was found to be valuable, since a different type of radiation is available there.  $1 \times 1 \text{ m}^2$  plates are penetrated by radiation emitted from a uranium plate which is exposed to the reactor's radiation. By measurements carried out on similar plate geometries at Saluggia and Geesthacht with identical instruments, a better understanding can be gained of the nuclear processes involved. The results are used for checking and improving computing methods which, once their reliability has been experimentally proved, can serve to calculate shielding specifications accurately and at low cost.

The RCN and Euratom's research centre at Ispra are participating in the theoretical work.

RCN experts are participating in the experiments which are being carried out at Geesthacht for the Dutch marine reactor project. While substantial progress has been achieved in the last few years, the studies devoted to possible ways of improving the measuring and calculation methods are still in full swing, so that the optimisation of radiation shielding cannot be regarded as completed yet.

### Optimisation of collision protection

Thanks to statistics on collisions which have actually occurred between conventional ships, which were of course not fitted with collision barriers, it proved possible to

determine the amount of impact energy absorbed by different types of hull. Probability calculations based on these statistics showed that the anti-collision structures designed and built hitherto afford a high degree of safety. The results of model tests are to be analysed in order to achieve even greater safety margins and to single out those types of structure which, while being more efficient, make possible lighter and cheaper collision barriers.

Four models of the bow section of the striking ship and four of the midships section of the struck vessel (scale 1:15) have so far been built and tested under the *Fiat-Ansaldo* contract.

A unit consisting essentially of a ramp for the bogie-mounted striking model, an attachment device for holding the struck model, and the measuring instrumentation, was made available by the University of Naples with *CNEN* backing. This rig differs from a *GKSS*-financed installation in Hamburg only in the method of fixing the struck model. At Euratom's suggestion, a collision will be produced on both test rigs between an identical pair of models, the struck model, as a conventional ship, having no collision barriers. By comparing each set of results both with one another and with those of an actual ship collision, their validity can be assessed.

The tests already carried out in Naples have shown that the degree of concurrence with actual conditions is adequate for comparison of the effectiveness of various anti-collision structures. The test programmes under way in Naples and Hamburg were drawn up jointly, and the results obtained are exchanged. Professor Spinelli, who is using the above-mentioned installation at the University of Naples for more general research on behalf of the *CNEN*, is also taking part in this exchange of information.

#### **Increasing the mechanical strength of reactor parts**

The risk that nuclear plant components, such as fuel elements, control rod drives, electronic control equipment, etc., might fail on board owing to inadequate mechanical strength can be largely discounted thanks to the test-rig set up at Geesthacht

with Euratom's participation. On this installation, which is electrically-operated and is of unique design, test samples weighing up to 2.2 tonnes can be simultaneously moved with a vertical 3 m travel and oscillated with a maximum amplitude of  $\pm 45^\circ$  for unlimited periods. In this way it is possible to simulate a ship's movements in a rough sea. The test samples can be subjected to accelerations up to a maximum of three times the acceleration due to gravity.

This "rolling-rig", which has been in constant use since its completion in 1962, has proved highly successful. In several cases unexpected mechanical flaws were detected in the test samples, leading to improvements in the design.

Euratom and the *GKSS*, which consult annually to decide on requests from interested parties who would like to use the rolling-rig, bear the cost of staffing and operating the installation. The construction and mounting of the test samples, on the other hand, are financed by the client.

#### **Collaboration in the European Community**

The above survey of the Euratom-backed programme for the development of nuclear-powered merchant ships clearly testifies to the value of collaboration between the parties concerned in the European Community. Further evidence of this are a number of sub-contracts, drawn up under the Euratom contracts already mentioned, with research institutes and firms throughout the Community. These include participation by the German *Allgemeine Elektrizitäts-Gesellschaft AG (AEG)* in tests conducted by *Fiat* and *Ansaldo* in the field of boiling-

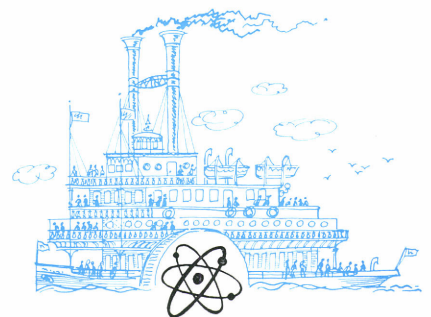



Professor Otto Hahn

water reactors, collaboration by the French firm of *Indatom* in the drawing up of construction plans for the *Otto Hahn* reactor, and the preparation of critical experiments to be carried out for the Italian project on the Dutch installation at Petten. Apart from certain individual areas of study, collaboration on fundamental matters is in the hands of a Community liaison committee, in which, in addition to Euratom and its contract partners, the governments of the Community countries and Euratom's Scientific and Technical Committee are represented. This committee regularly discusses and compares all the activities now in progress or projected in the Community in order to single out starting points for the orientation of further joint action.

In conclusion, it should be noted that while the development work on marine reactors now in progress in the Netherlands and Italy has not yet led to the adoption of a final design, those technical solutions which show promise are being followed up under the co-ordinated working programmes and there is good reason to expect that the nuclear merchant ships built in the Community after the *Otto Hahn* will at least reach the threshold of profitability.



EUBU 44

## Radioisotopes and radiations in the textile industry

GEORG PRÖPSTL, Head of the Bureau Eurisotop, Euratom

*The task of the Bureau Eurisotop is to promote the use of techniques involving radiations and radioisotopes in the industries of the European Community. How does it go about it? This is explained in the article below, which takes as an example an action programme launched recently in the textile industry.*

One of the major potential users of isotopes and radiations in Europe is the textile industry, representing about 10% of the entire industrial turnover. However, the extent to which this potential has hitherto been ignored is shown by the fact that of the 10,000 or so users of isotopes throughout the European Community less than 100 belong to the textile industry. A survey revealed that, out of 300 textile firms in the Community which are particularly receptive to new ideas and techniques, only 15 are at present using isotopes. Since there are at least 20,000 textile plants throughout the European Community, it is clear that the promoters of the use of isotopes have as yet barely gained a foothold in this industry, and, as can be seen from Table 1, the situation in other countries is very similar. Since savings of up to 1-2% of the total industrial turnover have been effected in the advanced countries by the use of isotopes, surely the considerable opportunities for rationalisation and economy which they offer are open to the textile industry too. This is especially true of the European Community's textile industry, which is at the moment faced with stiff foreign competition and at the same time is undergoing a period of structural and technical change.

These reasons warrant a special effort to bring about a fruitful union between nucleonics and textiles, fields which by nature have very little in common with each other.

### **Action undertaken by the Bureau Eurisotop**

One of the main aims of the scheme launched by the *Bureau Eurisotop* is therefore to build a bridge between the nuclear world and the textile industry. The success of such an undertaking depends on effective collaboration between a large number of qualified nuclear laboratories and textile firms. The *Bureau Eurisotop* therefore called upon laboratories and firms to participate in the Community's activities in this field. Thanks in particular to the vigorous assistance of the competent bodies in the textile industry, this appeal met with a ready response, a total of forty nuclear experts and 300 textile firms offering to participate. The project was launched recently, and the forty nuclear experts and the 300 textile firms are now jointly examining what concrete possibilities for the use of isotopes can be suggested to the textile industry.

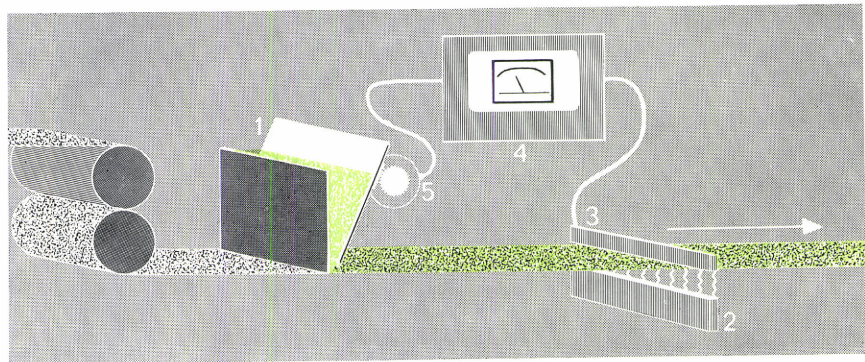

Figure 1: Radiometric thickness control.  
 The diagram represents a device (1) for depositing continuously a layer of, for example, glue (shown in colour) on a carpet.  
 The rays emitted by the radioactive source (2) are absorbed to a greater or lesser extent depending on the thickness of the glue. The counter (3) records on a dial (4) the radioactivity detected. It can therefore immediately indicate any abnormal change in thickness. The system can be fitted with an instrument which automatically stops the machine in such conditions, or with a servomechanism (5) which automatically regulates the glue-depositing device.

### Collaboration between nuclear experts and textile firms

The nuclear experts visit the textile works in order to:

- examine on the spot the possibilities for this use of isotopes and radiation;
- advise the factories concerned with regard to current isotope projects;
- and on completion of the visits, draft proposals, on the basis of the experience gained, with regard to the promotion of isotope applications in the textile industry.

Under this scheme, the textile firms, on the other hand:

- permit the nuclear experts to study the production plant in their factories;
- advise the nuclear experts in the elaboration of these studies;
- and investigate the practicability of the proposals put forward by the nuclear experts.

The results of this collaboration, which will extend over a period of several months, will be published in a number of reports to be distributed to the parties interested. In such an action, pursued as it is in direct contact with industry, it is, of course, essential that a distinction be drawn between that information which should be treated confidentially and that which can be pub-

Figure 2: Comparison of the efficiency of two detergents by means of a radioactive tracer.  
 Two identical samples of fabric contaminated by a radioactive product are dipped in tanks containing different detergents (1). The detergent is allowed to act (2), and then the radioactivity of the samples is counted (3). Less radiation will be emitted by the sample treated by the more efficient detergent.

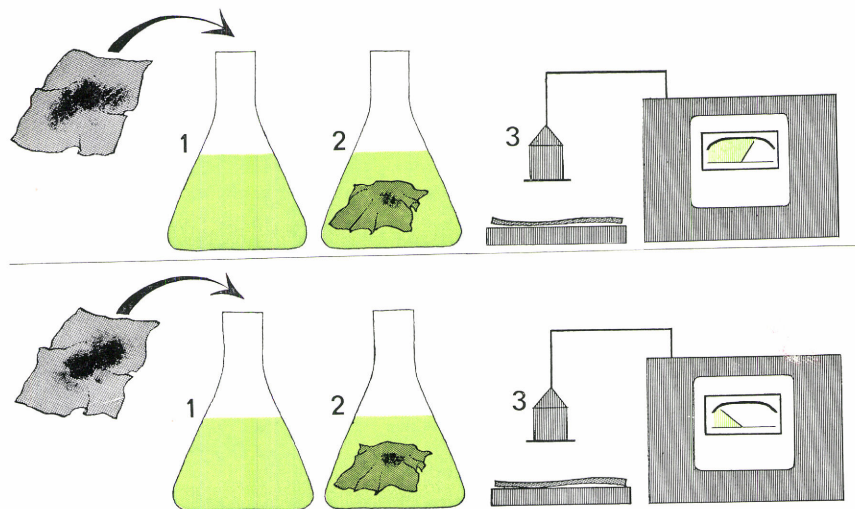

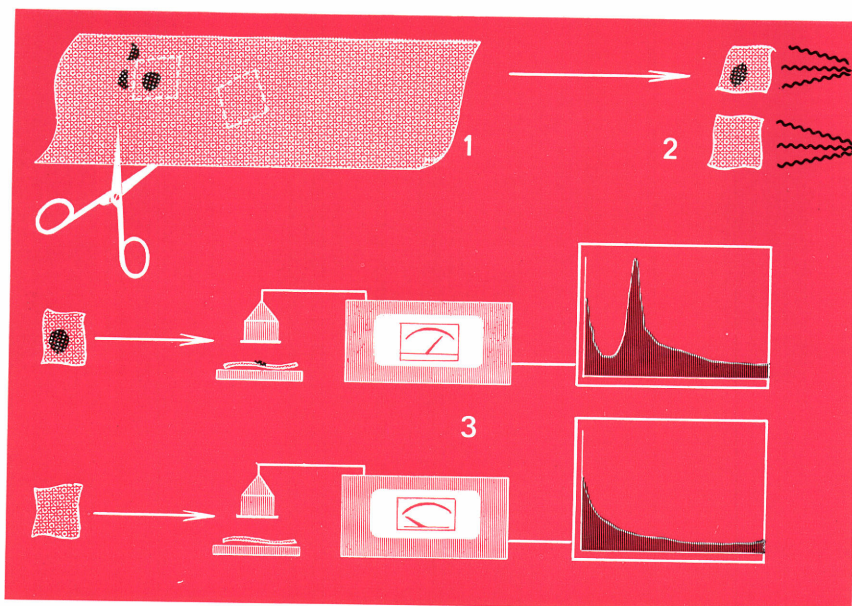
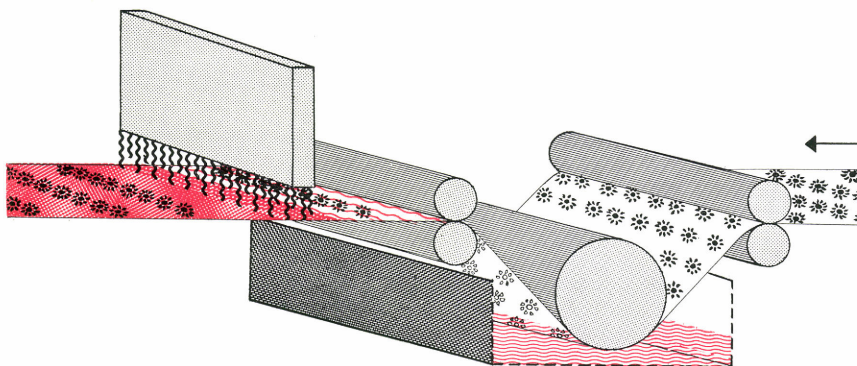

Figure 3: Activation analysis.

After a fabric has been dyed, it is observed that here and there the colouring matter has not impregnated it completely (1). It is suspected that some substance, probably a metallic element, present in trace amount, is inhibiting the action of the dye at these points, but this cannot be detected by conventional analytical processes. Accordingly, two samples, one coloured abnormally and the other normally, are subjected to neutron irradiation in order to render the elements they contain radioactive (2). The radioactivity of each element has its own characteristics, particularly as regards the energy of the radiation it emits. A spectrum can therefore be obtained for each sample (3) in which each peak corresponds to a well-defined element.

Figure 4: Radiation chemistry—example of grafting.

By grafting a styrene on to nylon, for example, a waterproof and more solid fabric is obtained. The grafting may be done by means of irradiation.



lished openly. For this reason all the nuclear experts engaged on this work are bound by a *Eurisotop* contract, this method having proved most satisfactory in other cases of a similar nature.

The *Bureau Eurisotop* has a budget of about 75,000 EMA u.a. for these study contracts. The relatively large expense involved in simply ascertaining the potential applications and their feasibility is occasioned by the complexity of the fields involved. The techniques used in both the world of isotopes and radiation and the textile industry are by no means standard.

#### Five categories of nuclear processes — fifteen branches of the textile industry

Taking account of the nature of the problem, we have chosen to divide up the nuclear techniques applied into the following five categories (see Figures 1 to 5):

- radiometric control methods;
- radioactive tracer methods;
- radiochemical methods, with particular reference to analysis;
- radiation chemistry;
- radioactive methods for removing static electricity.

Textile technology, on the other hand, was divided up into 15 different branches:

- the manufacture of synthetic and artificial filaments and fibres;
- the use of yarns made of synthetic and artificial filaments and fibres for spinning;
- cotton;
- wool;
- flax and hemp;
- jute;
- hard fibres and coconut fibres;
- sewing cotton;
- thrown silk, twisted yarn;
- knitwear;
- carpets, upholstery material;
- ribbons, galloons, elastic fabrics;
- embroidery, lace, curtains;
- printing on textiles;
- finishing.

It is difficult for a nuclear expert to acquire such as mastery of all nuclear fields that he is capable of putting forward constructive and original proposals for possible applications in every one of them, and the study of the entire range of textile technology would obviously cause him even greater headaches. On the other hand, however, it is barely possible for one single textile firm to

provide an accurate reflection of the various types of conditions encountered in practice, quite apart from the complications occasioned by the differences apparent between one branch of industry and another. The conditions obtaining with regard to the potential use of isotope technology in a factory employing 100 people are, for instance, different from those in one with 5000 on its payroll.

As a result of the above breakdown into five nuclear and 15 textile branches, we are faced with a net total of 75 separate fields of study which have to be divided up among those participating in the action programme and then covered by the written reports. Since some of these subjects can be left aside, some 30-40 individual fields of study remain. Generally speaking, each nuclear expert will cover one or two nuclear fields in their application to one or two branches of the textile industry, carrying out study trips to 5-20 plants in the process.

Substantial problems are raised by the organisation of these various studies and the establishment of contacts between nuclear experts and textile plants, and in an attempt to overcome them an action committee has been set up presided over by the head of the *Bureau Eurisotop*. The committee is made up of the Secretary-General of the *Co-ordination Committee of the European Textile Industry (Comitextil)* and five leading figures from the national textile organisations, together with five eminent specialists in the five nuclear fields concerned and the secretary for the entire project. The five representatives of the textile industry act as regional heads, while the five nuclear scientists are each responsible for one of the five nuclear fields.

### A few statistics

Figure 6 gives the breakdown according to country of the textile firms participating in the project.

An average total of 64% of the textile firms involved are of medium size, employing 100-1000 people; on average, 25% of the firms are large concerns with payrolls of over 1000, a figure which rises to 60% in the case of Italy and drops to only 9% for Belgium. Small firms employing 100 workers or less make up only 11% of the overall total, the figures for Belgium and the Netherlands

being 20% and 4% respectively. Not a single small Italian firm replied. From the standpoint of regional distribution, the main areas are concentrated round Flanders, Northern Italy, Eindhoven, Enschede, Krefeld, Lyons and the Upper Rhine (see Figure 7).

The firms taking part in the action programme were invited to indicate those nuclear specialties in which they are particularly interested. An analysis of the replies shows that radiometric control processes are well in the lead, 72% of the 292 enterprises concerned having expressed the wish to play host to an expert in this field. The overall breakdown can be seen in Figure 8.

An indication that the textile industry is already well informed with regard to the broad principles underlying isotope applications is afforded by the fact that only 15% of the firms have failed to express any precise wishes with regard to the qualifications of the isotope expert they require.

The interest displayed in nuclear techniques appears to vary considerably according to the branch of industry involved. Thus, the

users of synthetic fibres showed by far the keenest interest; but the concern of the textile industry in general emerges more clearly if we analyse the breakdown of visits requested (total 1800) by both branch of industry and nuclear specialty.

All sectors are extremely interested in the possibilities opened up by radioisotopes for the control and regulation of production. This is particularly true of branches using high-speed machinery or those with a high material output. Radiometric methods could also find their place in the manufacture of products having a large surface area (carpets, fabrics), especially when they are impregnated with other substances. Only in the processing of artificial and synthetic material (e.g., the production of ribbons) are radiometric control techniques in second place, after static electricity elimination methods. The use of tracers is mentioned particularly in cases where chemistry (finishing) or mixing problems play an important part. Radiation-chemical techniques for improving textile material seem to be regarded as particularly useful

Figure 5: Elimination of static electricity by air ionisation.

Radiation from a radioactive source ionises the air blown on the fabric to be processed, which makes it possible to eliminate the static electricity.

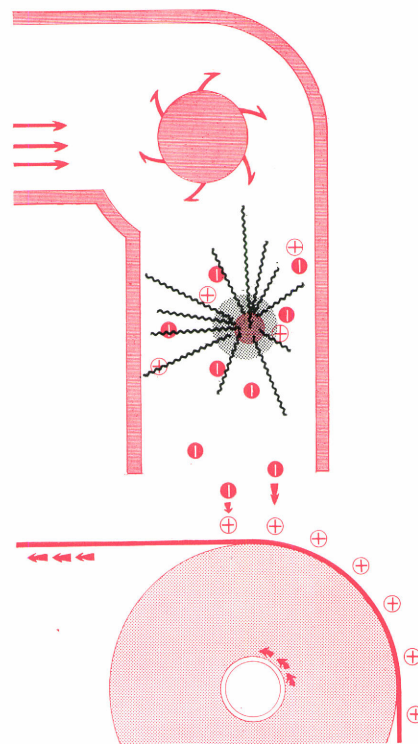

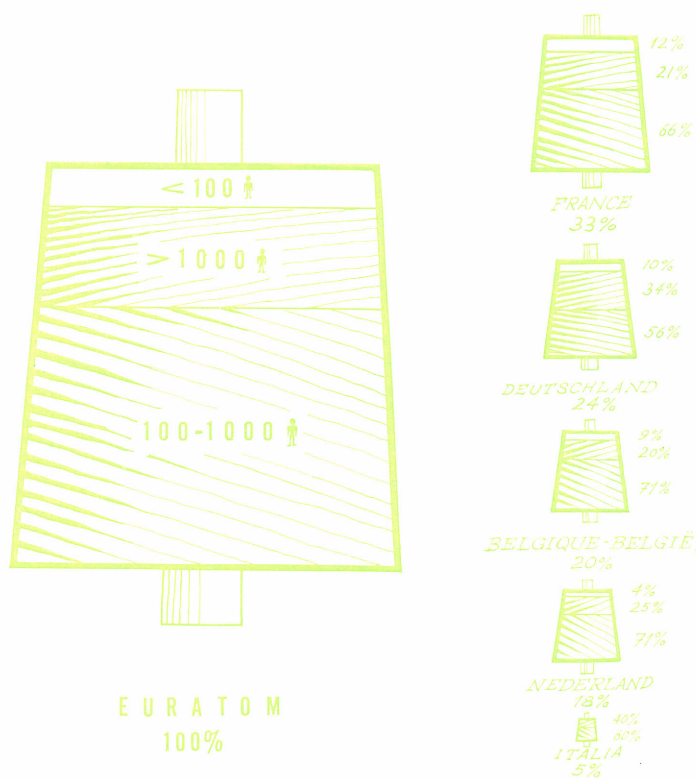

Figure 6: Breakdown by country of the textile firms taking part in the Bureau Eurisotop's action programme.

for monomer grafting on the surfaces of fibres and filaments (finishing, printing techniques), while radiochemical analysis is at present only mentioned by highly specialised plants and in special cases where delicate analytical problems have to be tackled.

#### Documentation

The action programme is centred on these study visits and the direct contacts established between the nuclear experts and the textile engineers. A further, and extremely valuable point of departure is the literature published to date. The various works on the subject are, however, widely dispersed and for that reason the *Bureau Eurisotop* has made a collection of all the references and literature, which will be made available to those participating in the project. Furthermore, experienced scientists are sifting the literature references and encoding their findings in the form of alphabetic lists of keywords. These lists, which convey an impressive idea of the importance of radiation and isotope techniques for the textile industry, are to be published. In addition to this purely scientific material, provision is also made for the publication of an information bulletin which is aimed

Table 1: Data obtained in 20 different countries on the use of radiations and radioisotopes.

Methods employed	Number of users		
	Industry as a whole	Textile industry	%
Radiometric control	1724	81	4.7
Radiography	1183	1	0.1
Elimination of static electricity	232	13	5.6
Tracer techniques	1106	14	1.3
Radiation chemistry	196	10	5.0
Miscellaneous	230	—	0.0
At least one of the above methods	4424	123	2.8

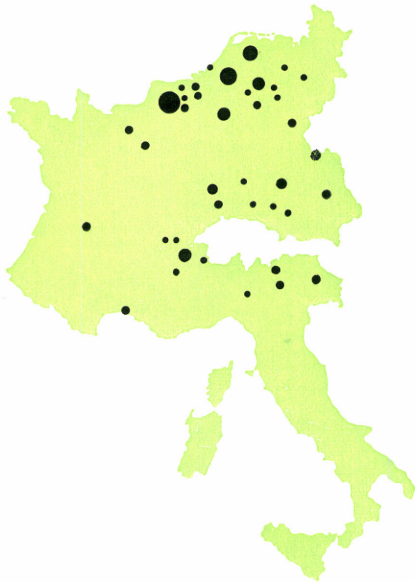

Figure 7: Geographical distribution of textile firms taking part in the Bureau Eurisotop's action programme.

more at providing a clear overall picture of the uses of isotopes in the textile industry.

The project described above represents a systematic investigation, but the path leading from the preliminary studies to actual application can, of course, be a long one. It is, however, to be expected that both the findings of the study and also the publicity and information deriving from this undertaking will prompt a great many textile firms to introduce isotopes in their plants. Although the use of isotopes is not always a simple affair, the belief that it is a highly scientific or extremely dangerous business is quite baseless. Owing to the novelty of isotopes and certain particular aspects of this technique, the essential conditions for their application must first be created, a task which requires the carrying out of basic research, the development of suitable equipment, methods and irradiation sources, and the drafting of new or amendment of existing regulations, etc.

The public authorities are also concerned with the solution of these problems. The programme will, for instance, provide for discussions attended by experts and representatives of competent organisations, at which the progress achieved will be reviewed and the appropriate consequences drawn.

It is possible that collaboration, especially in research, will occasionally be desirable, but the main initiative should then originate from industry itself. Both the national bodies and Euratom will lend every possible support to such action, depending on its importance for the economy as a whole. The *Bureau Eurisotop* plans, for instance, to participate shortly in a research project aimed at bringing about the direct application of radioactive materials in the textile industry.

The textile industry is essentially engaged in the weaving together of fibres into useful and sometimes fantastic fabrics. The introduction of isotopes can also be compared to a weaving process, nuclear technology being harmoniously woven into the fabric of conventional technology. In any assessment of this action it should be borne in mind that in the sphere of technology not only technical, but also human links have to be established across the barriers of language and nationality, in order to create a politically valid and vital and even, from many points of view, fascinating structure. And in this respect, too, those taking part, be they nuclear scientists or textile engineers, are making a contribution, the worth of which is fully recognised by the member states.

Figure 8: Wishes expressed by 292 textile firms regarding experts' visits, split up according to nuclear specialty.

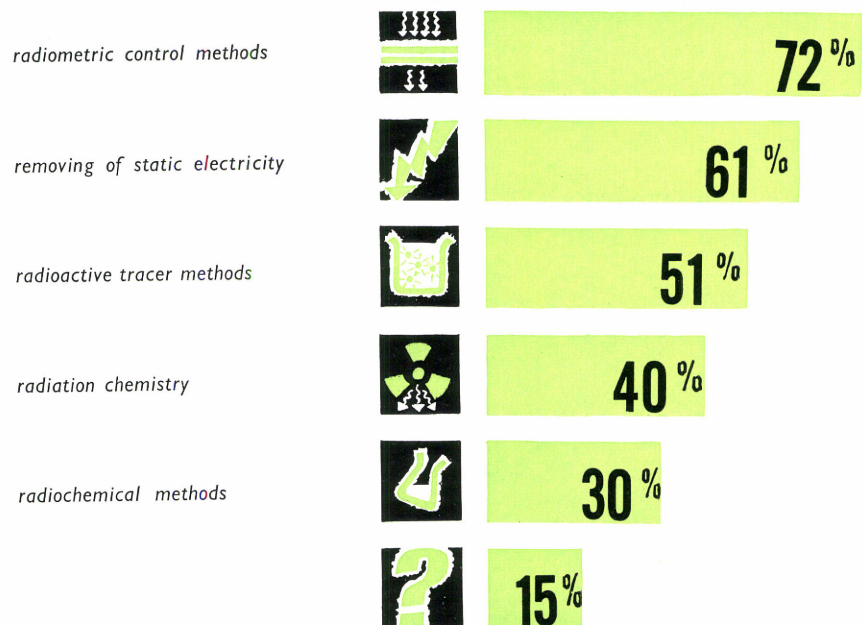

# EURATOM NEWS

## Testing a new zirconium alloy

Very early in the development of water reactors, zirconium proved a strong rival to stainless steel as cladding for fuel elements. In the pure state, although it has not the same mechanical and anti-corrosion properties as stainless steel, it offers the advantage of a lower thermal neutron capture cross-section.

Various attempts have therefore been made to improve zirconium's mechanical and corrosion-proof qualities by alloying it with other metals, — with some success, for the "Zircaloy-2" alloy developed in the United States is gradually ousting stainless steel in modern water reactors.

But the final outcome of this trend is not yet in sight: in fact, one section of the Euratom/United States Joint Research Programme is devoted to developing zirconium alloys of yet higher efficiency.

A metallurgical study of a zirconium-niobium(3%)-tin(1%) alloy, for instance, has been carried out under contract by the *Metallgesellschaft AG*, Frankfurt, followed by a long series of irradiation tests in the Geesthacht reactor, near Hamburg.

The study shows that the main advantage of this alloy over Zircaloy-2 lies in its considerably superior mechanical properties both at ambient temperature and more especially in the normal service range of 300°C and over.

The purpose of the in-pile test programme, completed recently, was to check the effect

of irradiation on the evolution of the mechanical and corrosion-resistance properties. For comparison purposes, simultaneous tests were performed on samples of ZrNb3Sn1 and reference samples of Zircaloy-2.

The cold state tests showed, for example, that the mechanical strength of ZrNb3Sn1 is 35% greater than that of Zircaloy-2, and that this margin improves to about 50% for a fast neutron dose of  $5.4 \times 10^{19}$  n/cm<sup>2</sup>.

At 300°C the initial advantage of 75% rises to nearly 100% for the same dose, keeping in the neighbourhood of 80% at 450°C.

As regards the corrosion tests, these showed that at the temperature studied, 400°C, irradiation has a considerable effect, producing a three-to-seven-fold increase in the corrosion rate as compared with samples subjected to identical treatment out-of-pile. It should be noted, however, that under similar conditions the oxide layer on the Zircaloy-2 reference samples was either thicker or even scaly (see illustration).

On the strength of these satisfactory results, ZrNb3Sn1 is being considered as a cladding for fuel elements, and it is hoped that an initial service test can be performed in the Kahl reactor.

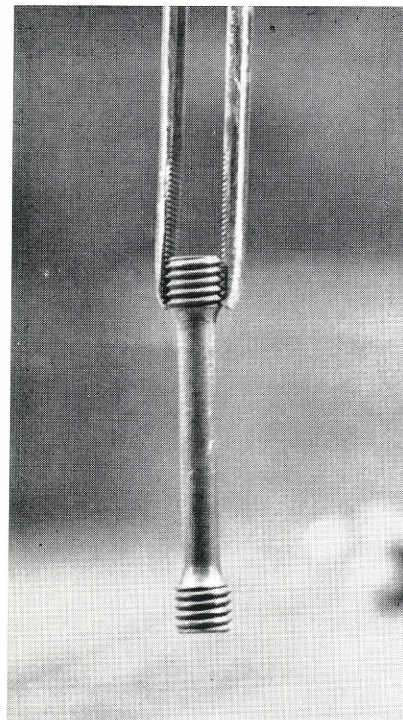
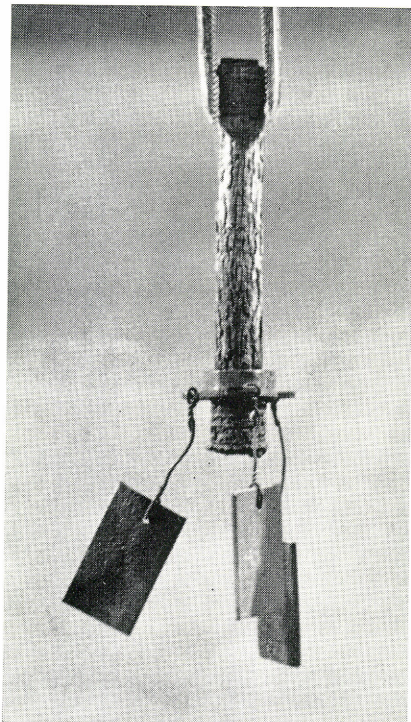

Two rods irradiated for 186 hours at 400°C (= a dose of  $1.7 \times 10^{19}$  fast neutrons/cm<sup>2</sup>). On left, a Zircaloy-2 rod; on right, a rod of ZrNb3Sn1.





— Sampling in the port of St. Goarshausen

— Preparation of sediments prior to analysis (Karlsruhe Nuclear Centre laboratory)



## How radioactive is the Rhine?

Under Euratom auspices, the representatives of the appropriate national authorities responsible for surveillance of radioactivity in the Rhine basin met together at the end of 1964 to examine the results achieved during the past year.

Two years ago, Euratom launched a wide-ranging study of the radioactivity in the Rhine and its main tributaries with the object of acquiring a better knowledge of the health and safety problems involved in the disposal of radioactive waste. The study is being carried out under a number of contracts concluded with the nuclear authorities of the countries concerned.

During the meeting, an analysis was made of the Rhine radioactivity data gathered at 42 different points.

In view of the size of the Rhine basin, the task of performing the required measurements at these 42 points had been assigned to 7 bodies. An interesting facet of this study is that the very first stage involved a joint decision on the methods to be employed as well as the standardisation of sampling and measuring devices.

The radioactivity levels in the water, the materials in suspension had the sediments have been accurately established. It was found that it was mainly the sediments which fixed the radioelements and that in this way they acted as a sort of purifier. On this basis, a more thorough study of the phenomenon was initiated. Whereas previously measurements had related to the overall radioactivity, efforts were now made to determine the fixation capacity of the sediments for each of the main radioelements liable to be discharged by industrial and medical installations or to originate from fall-out.

The value of the results obtained was such that it was decided to continue the study in 1965, but with the accent mainly on the fixative, and consequently cleansing, action of each of the chief sediment constituents. In this way, fundamental data will be obtained for use in the systematic study of radioactivity in the surface waters of river basins in general.

## Plutonium Recycling

Any nuclear fuel containing an appreciable proportion of uranium-238 — and this is the case with the fuel used in all “proven”-type power reactors, including enriched-uranium reactors—becomes a mixed uranium-plutonium fuel.

This is because the well-known phenomenon consisting in the conversion of uranium-238 into plutonium after neutron capture causes the plutonium atoms to combine with the uranium-235 atoms to form the reactor’s fissionable-material charge.

The very fact that this phenomenon occurs calls for a good knowledge of the neutronics of plutonium-containing fuels. But the recycling of plutonium in thermal reactors, i.e. extracting the unused plutonium from a fuel which has come to the end of its “life” in a reactor and then introducing it into a fresh fuel, raises a further set of problems, dealing with neutronics, technology and economics—which, moreover, differ considerably from reactor to reactor.

Particular interest attaches to the study of plutonium recycling in light-water and enriched-uranium reactors. For the development of an advanced recycling technique would make it possible, should a shortage of enriched uranium arise, to use a mixed fuel made up of natural uranium and plutonium instead of enriched uranium.

Again, it is not impossible that considerable stocks of plutonium will accumulate at some future date, the main determining factor being the rate of installation of thermal reactors, which produce plutonium, and fast reactors, which use plutonium. Should this actually happen, why not, instead of leaving plutonium idle, turn it to advantage by recycling it in thermal reactors?

The study of recycling in the European Community and the United States, which forms part of the United States/Euratom Joint Research Programme, is being carried out under a number of contracts, in particular those with the French Atomic Energy Commission (CEA), the CEN-BelgoNucléaire Group, General Electric and Westinghouse. This has resulted in a profitable two-way

# EURATOM NEWS



— Introduction of the element containing 12 plutonium-enriched rods into the BR 3 reactor transfer lock.

flow of information between Euratom and the US centre at Hanford.

A new contract on a cost-sharing basis has recently been concluded with the CEN-BelgoNucléaire Group, having a term of four years and a total value of 8,000,000 EMA u.a. It relates to two main fields, i.e.: On the one hand, neutron studies will be carried out on light-water  $UO_2$ - $PuO_2$  lattices with the aim of achieving geometries which will enable the maximum benefit to be derived from plutonium. These studies will be performed for the most part in pulsed sub-critical assemblies.

On the other hand, the work which has been in progress since 1960 on plutonium-containing fuel-element fabrication tech-

niques will be continued and backed up to an increasing extent by in-pile tests.

As far back as 1963, twelve plutonium-enriched rods were inserted in the BR 3 reactor. They were recently withdrawn after a burnup of approximately 6,000 MWd/t and in the near future will be subjected to a detailed examination; it can be stated even at this stage, however, that these rods appear to have come through the trials very successfully.

This initial experiment will be followed by a test on 20 rods, which will stay for three years in the BR 3 reactor (since converted into a *Vulcan*-type spectral shift reactor), up to a burnup of 30,000 MWd/t in the most exposed rod.

Example of Orgel-type composite power plant adapted to the requirements of a chemical complex.

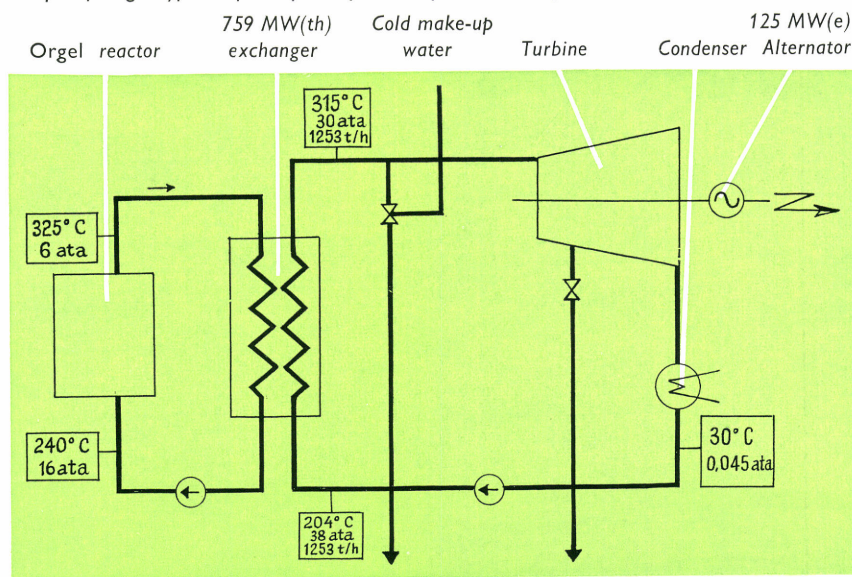

First-grade industrial steam—229°C 28 atm. abs. 300 t/h. Second-grade industrial steam—168°C 6 atm. abs. 200 t/h.

## A composite steam-electricity power plant of the OR-GEL type - is this a practical proposition?

The combined production of electricity and industrial steam for factories and mills would not at first sight appear to be a function to which nuclear reactors could be geared. The desired installations are in many cases too small to derive benefit from the steeper decrease in nuclear-plant investments in relation to conventional-plant investments above a few hundred MWe.

**ORDER FORM**  
**EURATOM BULLETIN**

I wish to subscribe to EURATOM Bulletin in

- English  Italian  
 German  Dutch  
 French

as from .....

- direct  
 through my bookseller .....

Name .....

Address .....

Signature .....

*Euratom Bulletin annual subscription (four issues) in the United Kingdom 18/—; in the United States: \$ 3.50*

Payment can be made by cheque or international money order to A.M.P., 34 rue du Marais, Brussels 1.

**ORDER FORM**  
**EURATOM BULLETIN**

I wish to subscribe to EURATOM Bulletin in

- English  Italian  
 German  Dutch  
 French

as from .....

- direct  
 through my bookseller .....

Name .....

Address .....

Signature .....

*Euratom Bulletin annual subscription (four issues) in the United Kingdom 18/—; in the United States: \$ 3.50*

Payment can be made by cheque or international money order to A.M.P., 34 rue du Marais, Brussels 1.

**index**

to volumes I, II and III (1962, 1963, 1964).

Volume, issue and page are indicated.

**GENERAL & MISCELLANEOUS**

- Jules Guéron: The administration of research** . . . . . I (1962), 2/11  
**Jules Guéron: Euratom and nuclear research - from the first to the second five-year programme** . . . . . I (1962), 3/2  
**Günther Grass: The Ispra research establishment** . . . . . I (1962), 3/21  
**Federico Consolo: The US/Euratom agreement for co-operation** . . . . . II (1963), 1/2  
**H. de Laboulaye: The French atomic programme** . . . . . III (1964), 4/3

**BIOLOGY, MEDICINE & AGRICULTURE**

- F. van Hoek: Radioisotopes in agricultural research** . . . . . I (1962), 1/15  
**A new step forward in the development of radionecrosis therapeutics?** . . . . . I (1962), 2/25  
**Albert J. Bertinchamps: Can tricks be played on life? (Molecular changes in the basic components of living organisms, caused by radiation)** . . . . . I (1962), 3/11  
**Prof. Hans Lettré: "Marked" molecules and their applications in biochemistry** . . . . . I (1962), 4/20  
**Padutine treatment of radionecroses - Further encouraging results** . . . . . I (1962), 4/32  
**Biology in Euratom's second five-year research programme** . . . . . II (1963), 3/8  
**Marcel Devreux: Pre-natal irradiation mutations** . . . . . II (1963), 3/16  
**Emilio Levi: A picture is worth a thousand words (Autoradiography in botanic research)** . . . . . II (1963), 3/21  
**First experiments in the Wageningen reactor** . . . . . III (1964), 1/32  
**Prof. Walter G. Verly: Preparation of marked molecules by biosynthesis** . . . . . III (1964), 2/21  
**Dr. Klaus Hempel: The storage of marked molecules** . . . . . III (1964), 2/29  
**Nuclear technology serves European agriculture** . . . . . III (1964), 3/3  
**Dr. Horst Gaul: Induction of mutations in barley at various stages of development** . . . . . III (1964), 3/10  
**Emilio Levi: Using radioisotopes to study plant growth** . . . . . III (1964), 3/12  
**Dr. D. de Zeeuw: Food irradiation - an improvement to human diet** . . . . . III (1964), 3/15  
**Oscar L. Staden: Irradiated mushrooms taste better** . . . . . III (1964), 3/18  
**An international conference on biomedical methods of preparing and using labelled compounds** . . . . . III (1964), 4/31

**CHEMISTRY**

- Chemistry and nuclear energy** . . . . . I (1962), 2/30  
**Prof. M. Zifferero: The rôle of the chemist in nuclear energy** . . . . . II (1963), 3/26  
**Marcel van der Venne: Organic coolants on trial** . . . . . III (1964), 1/7  
**Léon Stouls: The European transuranium institute** . . . . . III (1964), 2/8

- Louis Pichat: Chemical syntheses of marked molecules** . . . . . III (1964), 2/18  
**Prof. Fulvio Cacace: Labelling by radiochemical methods** . . . . . III (1964), 2/26  
**New data on the behaviour of organic liquids** . . . . . III (1964), 3/31

**ENGINEERING & EQUIPMENT**

- Hartwig Benzler: "Integrated" fuel handling in gas-cooled reactors** . . . . . III (1964), 4/17  
**Conference on technical problems in thermonuclear research** . . . . . III (1964), 4/32

**GEOLOGY & MINERALOGY**

- Isotopic analysis of Antarctic ice** . . . . . I (1962), 1/9

**HEALTH & SAFETY**

- J. P. G. M. Smeets: Radioactive contamination in the food chain** . . . . . II (1963), 3/10

**INDUSTRIAL APPLICATIONS OF ISOTOPES AND RADIATIONS**

- Eurisotop** . . . . . I (1962), 4/30  
**Dr. Hans Götte: The use of radioisotopes in the chemical and pharmaceutical industry** . . . . . II (1963), 3/26  
**European symposium on the use of radioactive tracers to track the movement of solids in water** . . . . . II (1963), 4/32  
**The Eurisotop bureau organises a meeting of activation-analysis experts** . . . . . III (1964), 1/31  
**Jean Sirchis: "Marked" molecules: modern research tools** . . . . . III (1964), 2/12

**MATHEMATICS & COMPUTERS**

- "Optimisation" of the "Orgel" nuclear power plants - development of a rapid calculating method** . . . . . I (1962), 4/32  
**François Lafontaine: ORgel optimisation** . . . . . II (1963), 3/2

**METALS, CERAMICS AND OTHER MATERIALS**

- Uranium oxide monocrystals of more than 1 cm diameter produced by C.E.N.** . . . . . I (1962), 3/33  
**Paul Fernet de Boisdeffre: UO<sub>2</sub> - Uranium oxide** . . . . . II (1963), 1/14  
**Emile Vanden Bemden: Plutonium, a synthetic source of energy** . . . . . II (1963), 1/22  
**A plutonium recycling experiment at Mol** . . . . . II (1963), 4/31  
**Philippe Berge: The battle against corrosion** . . . . . III (1964), 1/19  
**Canada/Euratom agreement - joint work on fuel elements** . . . . . III (1964), 1/33  
**Progress in counteracting brittle fracture in welded steel** . . . . . III (1964), 4/30

PHYSICS

**Donato Palumbo: Controlled thermonuclear fusion—A source of energy for the future** . . . . . I (1962), 2/2  
 Research on nuclear fusion—a new approach is investigated in Frascati Major results in Europe in the field of nuclear fusion . . . . . III (1964), 1/31

REACTORS

**J. C. Leny: The Orgel project** . . . . . I (1962), 1/3  
**BR 2 goes critical** . . . . . I (1962), 1/23  
**Gianfranco Franco: The Dragon project** . . . . . I (1962), 2/19  
**Wilhelm Sahl: Fast neutrons and fast reactors** . . . . . I (1962), 4/2  
**US/Euratom Agreement—power reactor programme** . . . . . II (1963), 1/5  
**Pierre Krays: The joint US/Euratom research and development programme** . . . . . II (1963), 1/8  
**Claude Chassignet: ESSOR** . . . . . II (1963), 2/12  
**U. Belelli, H. Nacfaire, M. Siebker: The Garigliano nuclear power plant** . . . . . II (1963), 4/4  
**P. Montois: The Latina nuclear power plant** . . . . . II (1963), 4/13  
**J. Ehrentreich, W. Kaut: The Ardennes nuclear power plant** . . . . . II (1963), 4/20  
**J. Desfosses, W. Kaut, J. S. Terpstra: The Gundremmingen nuclear power plant** . . . . . II (1963), 4/26  
**J. S. Terpstra: The Dutch nuclear power plant project** . . . . . II (1963), 4/28  
 The BR 2 reactor breaks a world record . . . . . II (1963), 4/30  
**Pierre Bonnaure: ECO—Expérience critique Orgel** . . . . . III (1964), 1/14  
 Euratom liaison meeting on nuclear ship propulsion . . . . . III (1964), 1/31  
 Development of graphite-gas reactors—Conclusion of a series of research contracts . . . . . III (1964), 1/33  
**Jules Guéron: Fast reactors in the European Community** . . . . . III (1964), 2/2  
**ORGEL—a thermal breeder reactor?** . . . . . III (1964), 2/33  
**Pietro Caprioglio, Mario de Bacci: How does the Dragon project stand?** . . . . . III (1964), 3/20  
 Euratom joins in construction of atomic ship . . . . . III (1964), 3/32

WASTE DISPOSAL & PROCESSING

**Françoise Laveissière, André Raggenbass: The problem of fission products—Elimination or recovery?** . . . . . III (1964), 4/12

LAW, ECONOMICS & INDUSTRY

**Reinhart Bauer: Euratom and the questions of liability and insurance in nuclear energy** . . . . . I (1962), 3/16  
**Hans Michaelis: Nuclear energy—a competitive source of electricity?** . . . . . I (1962), 4/10  
 The growing need for electricity and the means of satisfying it. . . . . II (1963), 2/2  
**A. A. de Boer: Planning the rôle of nuclear energy in electricity production** . . . . . II (1963), 2/4  
**Claude Ramadier, Edouard Parker: Euratom participation in power reactors** . . . . . II (1963), 4/2  
**Hans Michaelis: The economic outlook for proven-type power reactors** . . . . . III (1964), 1/2  
**Michel Gibb: The problem of uranium supply in Europe** . . . . . III (1964), 1/27  
 Studies on the economic aspects of nuclear energy. . . . . III (1964), 3/29

DOCUMENTATION

**Michel Gibb: Words and keywords** . . . . . I (1962), 3/26  
**J. C. Gardin: From archaeology to automatic data processing** . . . . . I (1962), 4/25  
**Rudolf Bree: Of needles and haystacks** . . . . . II (1963), 2/18  
**Carlo Vernimb: Research and information** . . . . . III (1964), 3/24  
 The use of "nuclear" patents as an information source . . . . . III (1964), 3/28  
**Rudolf Bree: Information and the management of research** . . . . . III (1964), 4/26

EDUCATION AND TRAINING

**Etienne Hirsch: A site in Florence for the European University** . . . . . I (1962), 1/19  
 Euratom courses at nuclear research centres . . . . . II (1963), 3/31  
 Training in Euratom research establishments . . . . . III (1964), 1/32

— The glove-boxes of the CEN-Belgo-Nucléaire Group laboratory, in which the plutonium-enriched elements are fabricated.



Furthermore, the low temperature levels which suffice for steam generation (150° to 200°C) are reflected in very substantial savings on boilers and not on reactors.

The result is that nuclear investments per unit are twice to three times as high as conventional investments, against one and a half times to twice as high where electricity production alone is concerned.

Even so, a preliminary study has been carried out for a composite-type power plant equipped with an *Orgel* reactor and designed for use in a chemical complex. A comparison with a conventional facility on the basis of annual charges favours the adoption of a nuclear plant, mainly by reason of the appreciable difference in fuel costs between the two types. This, however, postulates a fuel-oil cost above 20 dollars/ton.

It is also possible to conceive of an *Orgel* reactor as a source of heat for a combined electricity and desalted-water production

unit. This might be an even better proposition, as very large reactors could be constructed without insuperable technolo-

### **Technetium-99 — a weapon in the fight against corrosion?**

Euratom recently drew up a contract with the Jülich research establishment in *North Rhine-Westphalia* concerning the production of a little-known radioisotope, technetium-99. This element, which does not occur in nature, is only found in uranium fission products. However, a peculiar feature of it is its very long half-life (500,000 years) and

gical problems. A wide programme is planned by the United States Atomic Energy Commission in this field.

its very weak beta-radiation. It can therefore almost be regarded as a stable element for certain purposes.

The important properties of technetium-99 include its super-conductivity at low temperatures and in particular its astounding efficiency as an anti-corrosion agent. For this reason it could possibly be used in solution in water or as an alloying element in metals to be protected against corrosion. The work in progress at Jülich is aimed at the development of a process for separating this extremely interesting isotope from fission products.



radioisotopes radioisotopi radioisotopen s  
hip propulsion schiffs antrieb propulsion na  
vale propulsione nava le scheepsvoortstuw  
ing biology biologie biologie biologia bio  
logie médecine mediz in médecine medicin  
a geneeskunde healt h protection gesundh  
eitsschutz protection sanitaire protezione s  
anitaria bescherming van de gezondheid  
automatic data proces sing automatische inf  
ormation information automatique informa  
zione automatica auto matische verwerking  
van gegevens insura nce versicherungswes  
en assurances assicura zione verzekeringen  
economics wirtschaft économie economia e  
conomie education and training ausbildu  
ng enseignement inse gnamento onderwijs  
en opleiding power reactors leistungsreak  
toren réacteurs de pu issance reattori di po  
tenza energie reactor en nuclear fusion ke  
rnverschmelzung fusi on nucléaire fusione  
nucleare kernversmel ting radioisotopes r  
adioisotope radioisot opes radioisotopi ra  
dioisotopen ship pr opulsion schiffsantrie  
b propulsion navale propulsione navale  
scheepsvoortstuw ing biology biologie biolo  
gie biologia biologie médecine mediz in mé  
decine medicina gene eskunde health pro  
tection gesundheitssc hutz protection sanit  
aire protezione sanita ria bescherming van  
de gezondheid auto matic data processing  
automatische informa tion information auto  
matique informazione automatica automatis  
che verwerking van g egevens insurance v  
ersicherungswesen as surances assicurazioni  
verzekeringen econ omics wirtschaft éco  
nomie economia eco nomie education and  
training ausbildung enseignement insegn  
amento onderwijs en opleiding power reac  
tors leistungsreakto ren réacteurs de pu  
issance reattori di po tenza energie reactor  
en nuclear fusion ke rnverschmelzung fusi  
on nucléaire fusione nucleare kernversmel  
ting radioisotopes r adioisotope radioisot  
opes radioisotopi ra dioisotopen ship pr  
opulsion schiffsantrie b propulsion navale

